

| BILL OF MATERIALS | | |
|-------------------|----------|--|
| ITEM No. | PART No. | DESCRIPTION |
| 1 | 10001391 | HBA TOP POST – POST 1 (830mm LG) |
| 2 | 10001393 | HBA BOTTOM POST – POST 1 (1850mm LG) |
| 3 | 10001396 | SYT POST – POST 2 & 3 |
| 4 | 10001218 | BEARING PLATE (200 x 200 x 16) |
| 5 | 10001400 | ANGLE STRUT |
| 6 | 10001419 | EXTRUDER HEAD |
| 7 | 10001416 | 1ST RAIL 3.81m PUNCHED FOR ANCHOR |
| 8 | 10000985 | W-BEAM RAIL 3.81m NLL |
| 9 | 10000719 | 2m CABLE ASSEMBLY |
| 10 | 10001422 | CABLE ANCHOR FITTING |
| 11 | 10001397 | KING BLOCK (190mm WIDE) |
| 12 | 10001300 | 5/8" x 10" LG. POST BOLT – MUSHROOM HD |
| 13 | 10001298 | 5/8" FLAT WASHER |
| 14 | 10001299 | 5/8" HEX NUT |
| 15 | 10001248 | M16 x 32LG. SPLICE BOLT – MUSHROOM HD |
| 16 | 10001239 | M16 OVERSIZED NUT |

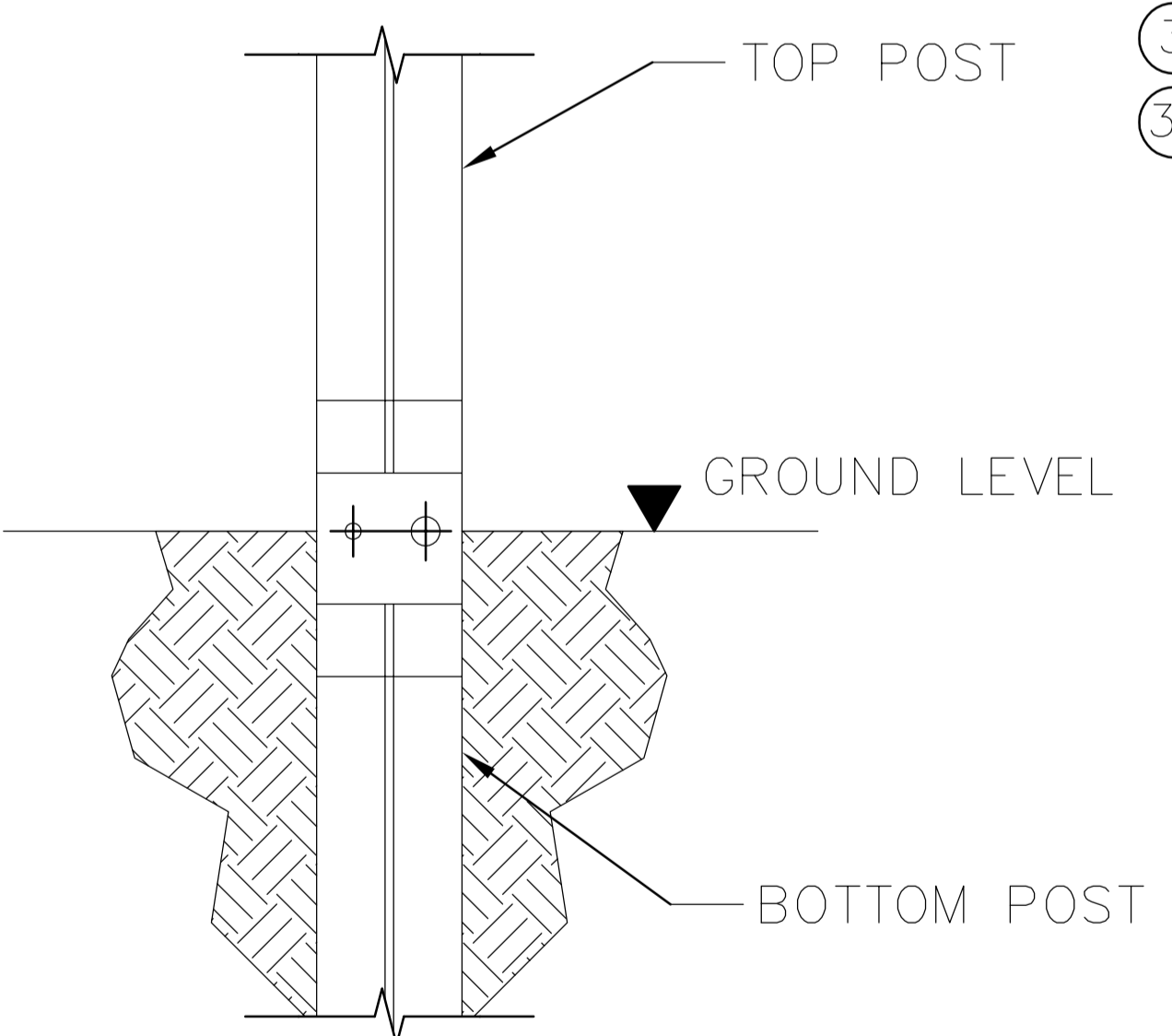
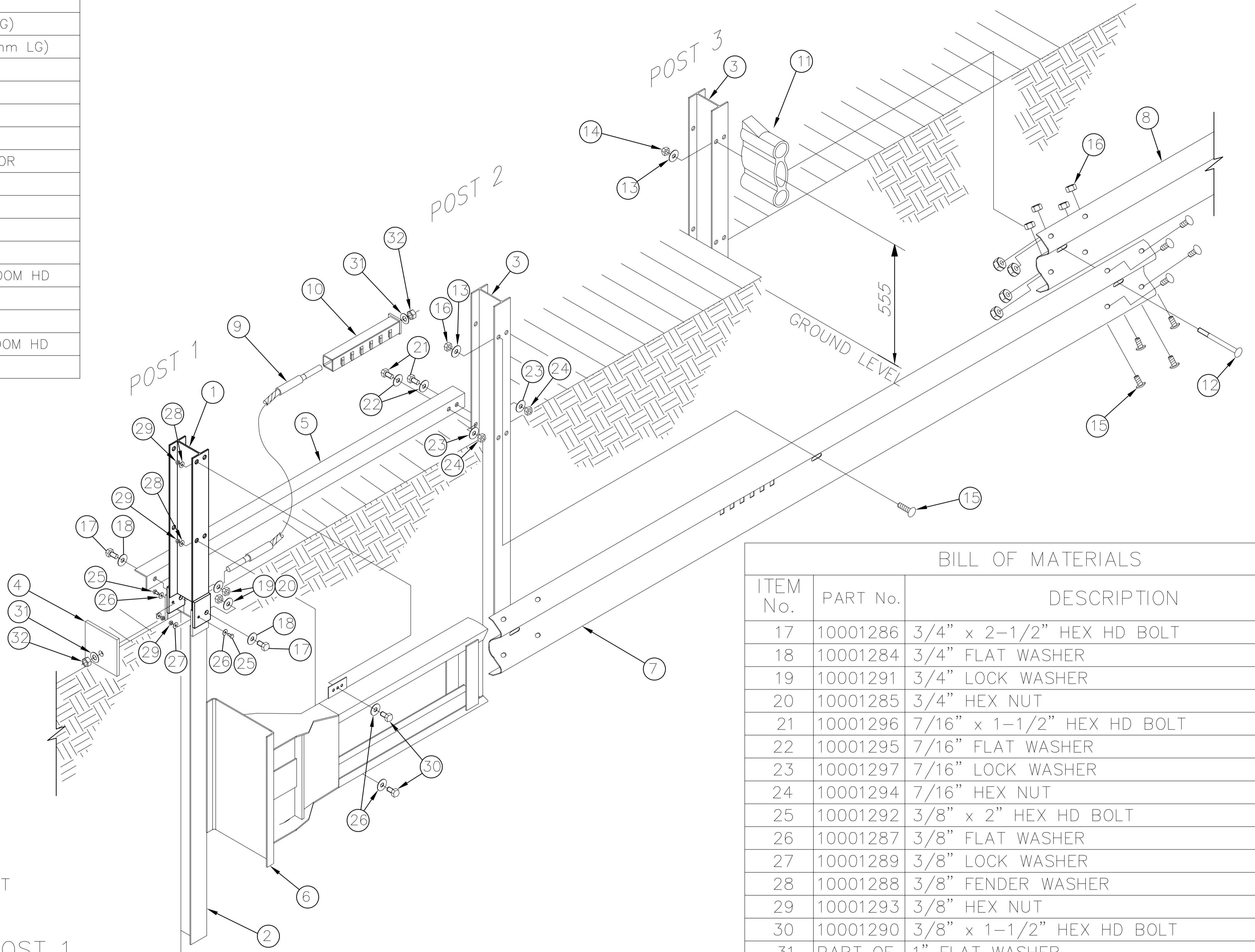

DRIVING DEPTH DETAIL FOR POST 1
SCALE 1:100

| BILL OF MATERIALS | | |
|-------------------|----------|----------------------------|
| ITEM No. | PART No. | DESCRIPTION |
| 17 | 10001286 | 3/4" x 2-1/2" HEX HD BOLT |
| 18 | 10001284 | 3/4" FLAT WASHER |
| 19 | 10001291 | 3/4" LOCK WASHER |
| 20 | 10001285 | 3/4" HEX NUT |
| 21 | 10001296 | 7/16" x 1-1/2" HEX HD BOLT |
| 22 | 10001295 | 7/16" FLAT WASHER |
| 23 | 10001297 | 7/16" LOCK WASHER |
| 24 | 10001294 | 7/16" HEX NUT |
| 25 | 10001292 | 3/8" x 2" HEX HD BOLT |
| 26 | 10001287 | 3/8" FLAT WASHER |
| 27 | 10001289 | 3/8" LOCK WASHER |
| 28 | 10001288 | 3/8" FENDER WASHER |
| 29 | 10001293 | 3/8" HEX NUT |
| 30 | 10001290 | 3/8" x 1-1/2" HEX HD BOLT |
| 31 | PART OF | 1" FLAT WASHER |
| 32 | 10001422 | 1" HEX NUT |

| REV | DATE | DESCRIPTION | DRAWN | CHECKED | APPROVED |
|-----|----------|---------------------------|-------|---------|----------|
| D | 11/10/11 | TITLE BLOCK UPDATED | DJB | TC | TC |
| C | 24/02/09 | TITLE BLOCK UPDATED | MS | TC | TC |
| B | 19/05/04 | ITEM 11 CHANGED | IJ | BF | GPP |
| A | 22/03/04 | BILL OF MATERIALS AMENDED | IJ | BF | GPP |
| 0 | 10/02/04 | INITIAL ISSUE | BF | IJ | GPP |

| DRAWING NUMBER | REFERENCE DRAWINGS |
|----------------|--------------------|
| | |
| | |
| | |
| | |

| | NAME | DATE |
|----------|--------|------------|
| DRAWN | AUSTEC | 11/10/2011 |
| CHECKED | TC | 11/10/2011 |
| APPROVED | TC | 11/10/2011 |
| SCALE | NTS | |
| SIZE | A1 | |

INGAL CIVIL PRODUCTS
57-65 AIRDS ROAD
MINTO, N.S.W
AUSTRALIA 2566
PH. +61 2 9827 3333
FAX +61 2 9827 3300
www.ingalcivil.com.au

DRAWING AND CONTENTS ARE COPYRIGHT TO
INGAL CIVIL PRODUCTS AND CAN ONLY BE USED
WITH PRIOR WRITTEN CONSENT FROM INGAL CIVIL
PRODUCTS

| | |
|---------|---------------------------------------|
| PROJECT | ET2000 PLUS NCHRP 350 TEST LEVEL 3 |
| TITLE | ISOMETRIC ASSEMBLY POSTS 1, 2 & 3 |

| | |
|---------------------------------------|------------|
| INGAL CIVIL PRODUCTS REFERENCE No. | |
| DRAWING No. | CAB-STD-63 |
| REV. D | |