

34 O.D. SPIGOT
OR 42 O.D. SPIGOT
(CUSTOMER TO ADVISE)
UPLIFT 5°

R1500

AC1542DO
42 O.D. SPIGOT

AC1534DO
34 O.D. SPIGOT

AV1FD

DOOR 295 x 90
CLEAR OPENING
2- CONTROL GEAR
MOUNTING STRAPS

6550 NOM. OVERALL HEIGHT

4700

300

295

800

160 O.D.A.F.

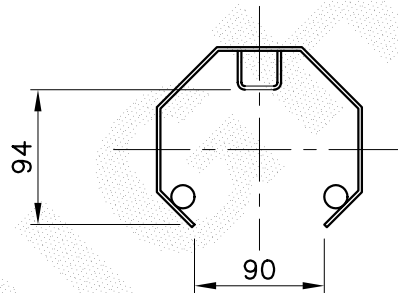

CONTROL GEAR CLEARANCES

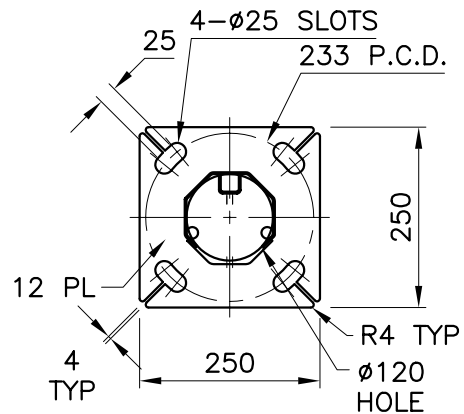

BASEPLATE DETAIL

NOTES:

1. ALL STEEL COIL TO CONFORM TO AS/NZS 1594 GRADE HU300 U.O.N.
ALL STEEL PLATES TO CONFORM TO AS/NZS 3678 GRADE 250 U.O.N.
2. ALL STEEL BARS AND SECTIONS TO CONFORM TO AS/NZS 3679 GRADE 250 U.O.N.
3. ALL WELDS TO CONFORM TO AS/NZS 1554 PART 1
4. ALL TAPER LOCK JOINT LENGTHS ARE NOMINAL U.O.N.
5. ALL STEEL TO BE FULLY HOT DIP GALVANIZED AFTER FABRICATION
IN ACCORDANCE WITH AS/NZS 4680

1	13/11/02	CATALOGUE NUMBER WAS SAL65F-D15	I.W.	<i>[Signature]</i>
0	4/12/98	REDRAWN FROM SL461 & UPDATED	I.W.	<i>[Signature]</i>
REV	DATE	DESCRIPTION	BY	CHKD
CUSTOMER/PROJECT				

COPYRIGHT
THIS DOCUMENT PRODUCED
BY INGAL EPS MUST NOT
BE COPIED, TRACED,
REPRODUCED, OR LENT
WITHOUT WRITTEN CONSENT

DIMENSIONS IN MILLIMETRES



DO NOT SCALE

CHECKED BY *[Signature]* DATE 9/12/98

INGAL EPS

STREET LIGHTING
6.5m, 1.5m DOUBLE OUTREACH AVENUE
BASEPLATE MOUNTED
RIVERTON DESIGN

CATALOGUE NUMBER
SAL65FDO15
DRAWING NUMBER
SAL65FDO15

DATE 4/12/98

DRAWN BY I. WHITE

SCALE 1:40

CAD FILE No. Z:\ACAD\STD\AVENUE\SAL65F-D15