

BEAUTIFYING STREETS BY DAY, LIGHTING THEM BY NIGHT

Valmont offers the broadest selection of light poles in the world for new and existing projects and our structures will enhance any roadway or residential area.



(LEFT & TOP) STREET LIGHT POLES INSTALLED AT HYDERABAD OUTER RING ROAD; (BOTTOM) STREET LIGHT POLES INSTALLED IN GOA

PROVIDING ESSENTIAL VISIBILITY & SAFETY

People gain an important sense of safety and security when neighbourhood and city roadways are well illuminated with street lights. Possessing a passion for quality, service and innovation, Valmont designs, manufactures and supplies decorative and conventional street lighting poles and lamp posts that are installed in cities across the country.

PRODUCTS ENGINEERED WITH SECURITY, LONGEVITY & ARTISTRY IN MIND

Our unmatched access to durable and diverse resources guarantees the best final result for your project. With tapered and non-tapered steel, decorative and semi-decorative options, our structures can satisfy demands for stylish, economical, and low-maintenance materials.

CUSTOMISED ENGINEERING

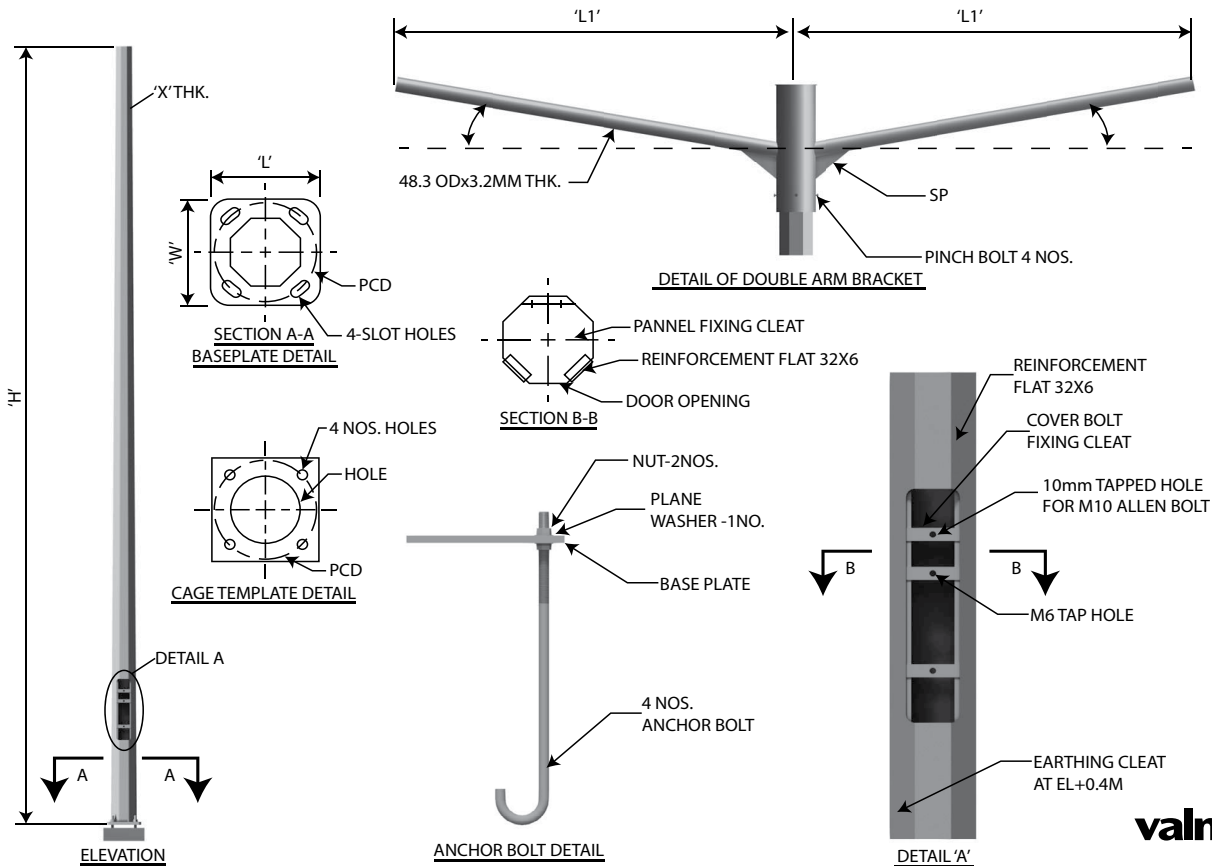

valmont STRUCTURES

By considering the weather conditions, usage, and aesthetics related to your project, we use our expertise to recommend the longest-lasting materials based on years of research and extensive testing. We can assist at every stage of the engineering and manufacturing process, from design concepts and renderings, to sales proposals and marketing support. We ensure that our poles conform to various international industry standards and specifications.

- The structure is suitable for wind speed as per IS 875 Part III 2015 and PLG 07.
- The pole is fabricated from special steel plates, conforming to ASTM A 572/BS EN 10025.
- The welding is in accordance with the American Welding Society (AWS).
- The entire pole is single hot-dip galvanised, internally and externally as per ASTM A123 and A153.
- The top and bottom diameters and plate thickness of the poles are designed as per EN 40.
- The design life of the poles is a minimum of 25 years.



Up to 12 Metres
in Height

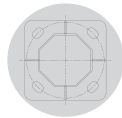

Traditional
Base Plate Design



Available with
Decorative Brackets



Hot-Dip Galvanised
for Better Protection

To know more about products manufactured by Valmont in India, please visit our website www.valmont.in.

Find us on Facebook



www.facebook.com/valmont.india

Follow us on



@ValmontIndia

Copyright © Valmont Structures Pvt. Ltd. All Rights Reserved. This document is the sole property of Valmont Structures Pvt. Ltd. No part of this document may be reproduced, stored in a retrieval system, or transmitted in any form or by any means - electronic, mechanical, photocopying, recording or otherwise - without prior written permission of the concerned authority. © All Rights Reserved.