

Product and Installation Manual

BG800 Gate

**NCHRP 350 TL-3
Australia & New Zealand**

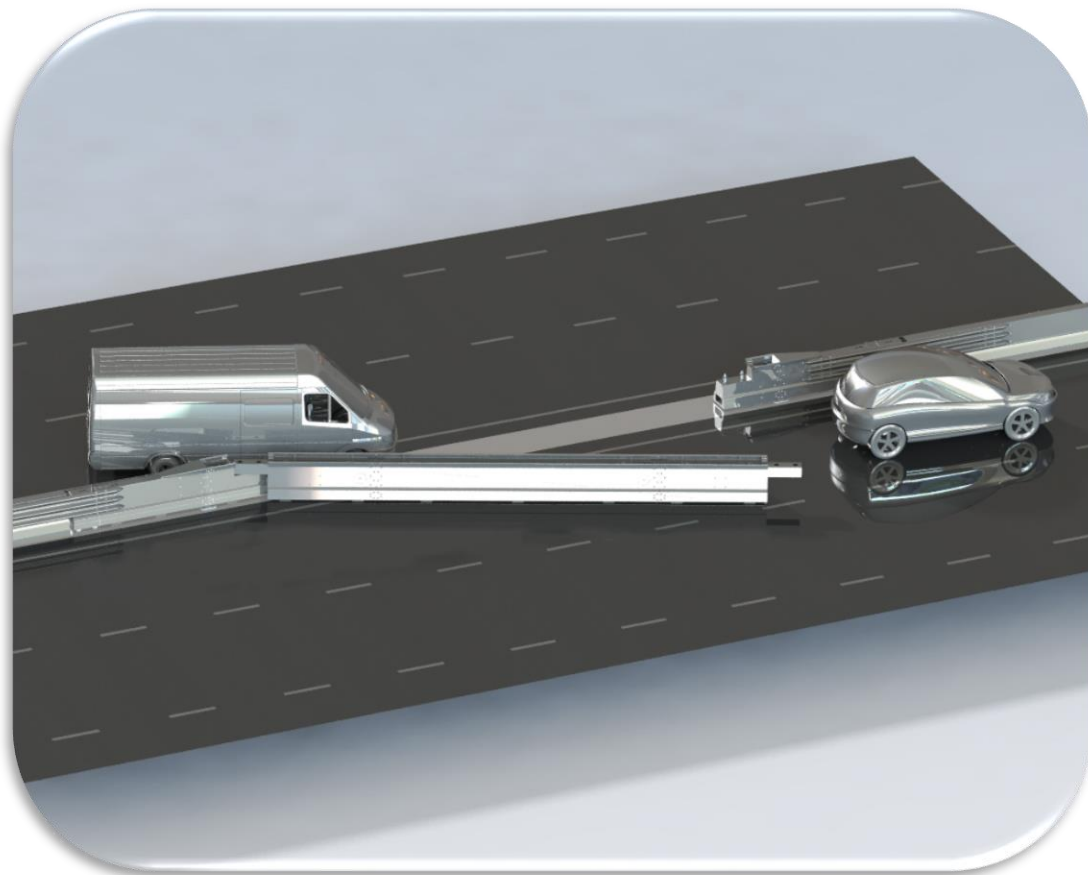

Revision History

Revision	Date	Prepared by	Approved by	Reason for change
A	June 2017	O. Pulling	W. Duckworth	New branding - first issue.
B	Oct 2018	A. Marsh	O. Pulling	Product name update

contents

Introduction	3	Step 03 –Position.....	11
Testing & Acceptance	3	Step 04 – Connection.....	11
Characteristics.....	3	Step 05 – T-Top	11
Design Considerations.....	4	Step 06 – Anchor	12
Median and Roadside Applications.....	4	Step 07 – System Check.....	12
Connection.....	4	Operation	13
Environment.....	4	Maintenance & Repair	14
Gate Length	4	Photo Examples	15
Anchoring Options.....	5	Frequently Asked Questions.....	16
Deflections.....	5	Appendix.....	18
Standard Opening Options	6	Foundation Details	18
Component Identification	7	Anchor Installation Detail.....	20
Safety Statements	8	Resin Anchor Studding.....	20
Installation Instructions	9	Mechanical Anchor Bolt	20
Preparation.....	9	Installation Checklist Example.....	21
Tools & Equipment.....	9	Approvals.....	22
Installation.....	10	Contact Details.....	23
Step 01 – Measuring	10		
Step 02 – Assembly	10		

Introduction

The BG800 Gate is a modular system that is made up from special sections of BG800, these are listed below;

- Gate post sections
- Gate hinge sections
- Gate sections

The BG800 Gate can be utilised as a permanent or temporary application and installed directly into a run of BG800 or by utilising one of the connection pieces can be used as a stand-alone system attached to various safety barriers & fences including, but not limited to; concrete and thrie beam to w-beam.

Testing & Acceptance

The BG800 Gate system has been designed and tested to meet the evaluation criteria of NCHRP 350 Test Level 3 (TL-3) and has been given eligibility by the Federal Highways Administration (FHWA). It is approved for use in USA, Australia and many more countries.

BG800 Gate smoothly redirects a vehicle during an impact that meets the test parameters of NCHRP 350.

Characteristics

BG800 Gate has been designed for both permanent or temporary applications and acts as a longitudinal barrier when closed. Common uses include;

- Emergency vehicle access
- Work zone access
- Contraflow opportunities
- Controlled access point

Note: This manual is designed to complement the gate drawing package provided. Where Highway Care bespoke gates are designed the project drawings take priority over this manual.

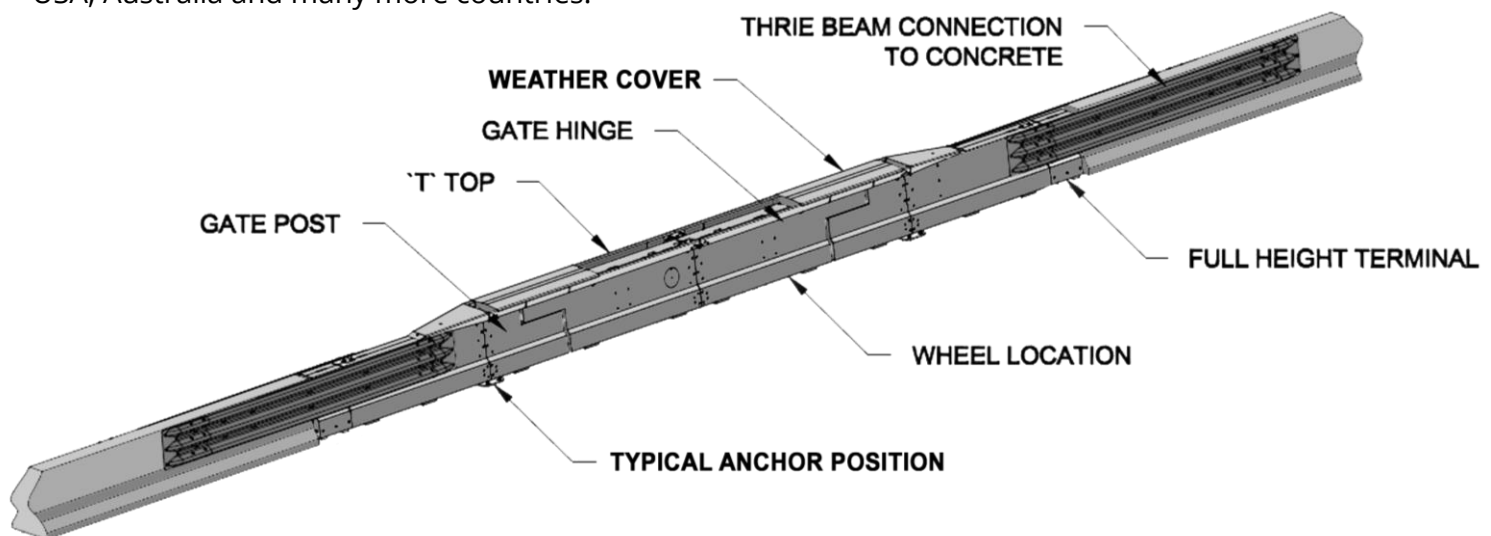

Design Considerations

Median and Roadside Applications

The BG800 Gate can be impacted from either side of the barrier with no difference in performance levels. Therefore, the barrier can be used in both median and road side situations in either orientation; as long as the site condition has sufficient space and suitable ground conditions.

Connection

Connections from the BG800 Gate to other types of barriers are possible (thrie beam, w-beam, concrete and BG800). Examples are below. Additional connections are available; please contact Highway Care for further details.

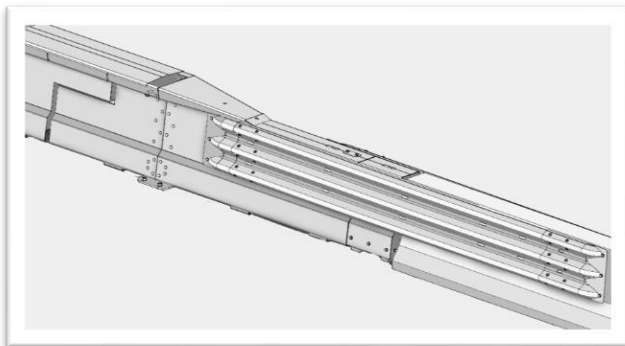

Connection to precast or slip form concrete

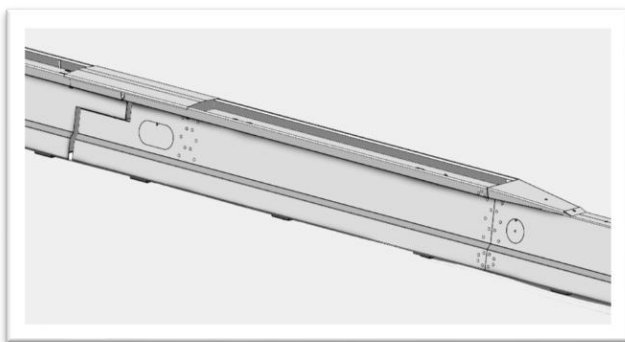

Connection to BG800

As the gate is anchored at the full height terminal/gate post no strength is required from adjoining barrier for the system performance.

Environment

BG800 Gate should not be installed where there are ditches or kerbs that may affect operation of the gate. It is recommended that the gate is installed on straight sections but slight curves can be accommodated.

The BG800 Gate works on slopes, but it is recommended that the cross fall does not exceed 5% to allow controlled manual operation.

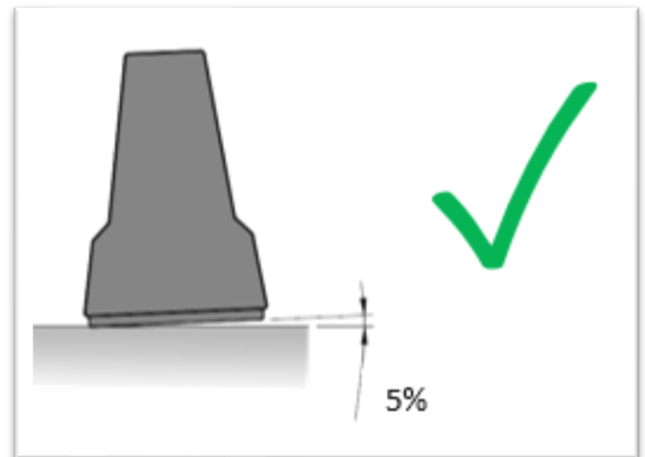

Note: Care must be taken when opening the gate on a slope as the gate can move by itself when detached from both hinges with the wheels down.

Gate Length

Standard gate lengths are 6m, 12m, 18m, 24m, 30m and 36m. These gate sizes provide openings of 4.67m, 10.67m, 16.67m, 22.67m, 28.67m and 34.67m respectively.

Please contact Highway Care for bespoke sizing options.

Anchoring Options

The BG800 Gate requires anchoring with sufficient strength from the supporting ground conditions, to allow the gate to perform as tested. The appendix contains further details for foundation options.

Deflections

Deflection measurements from actual crash testing provides a setting that can be useful when assessing a products suitability to perform at a given location.

Tested Parameters

Test Standard	Performance Level	Test Reference	Vehicle Type	Impact Speed (km/h)	Impact Angle (°)	Vehicle Mass (kg)
NCHRP 350	TL-3	3-21	Pickup	100	25	2000

Test Result

Dynamic Deflection	1.16m
---------------------------	--------------

Standard opening options

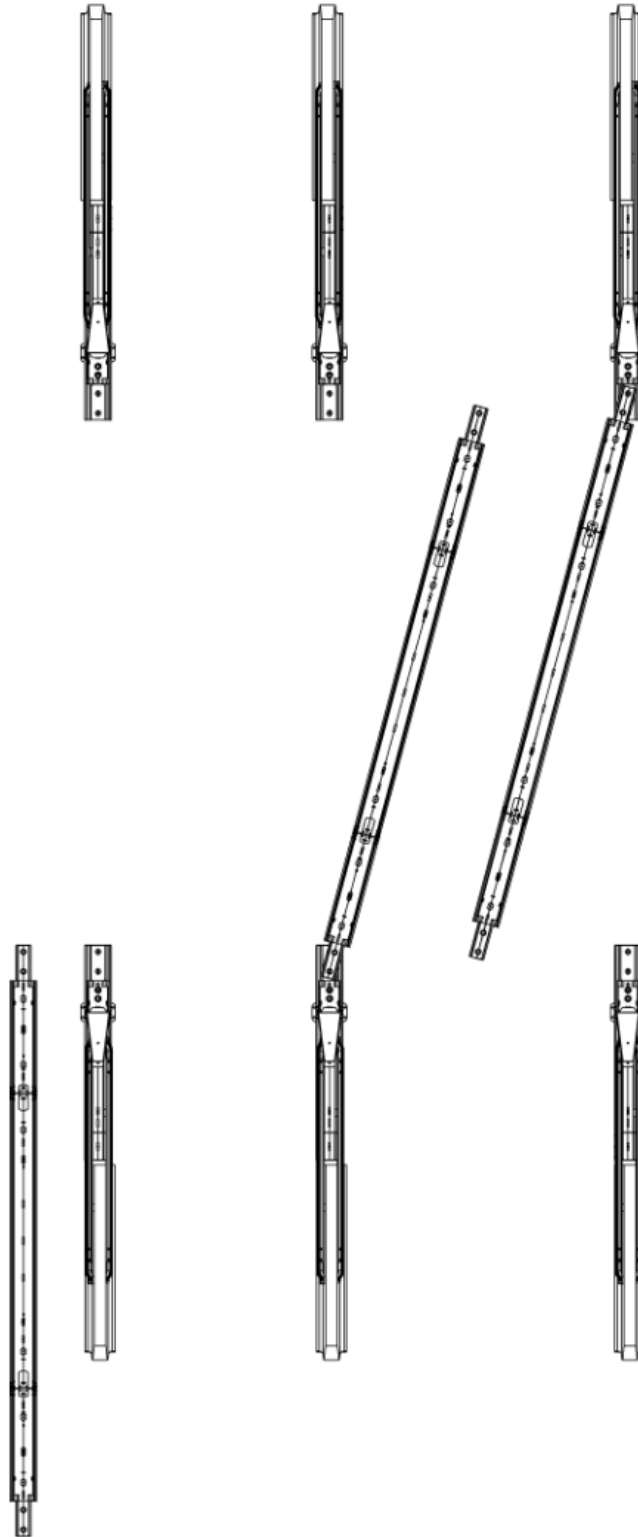

Component Identification

Fixed Gate Post	Mobile Hinge	Gate Section
		
T-Top	T-Top Transition	Weather Cover
		
Removable T-Top Section & Fittings	Gate Pin	
		

Safety Statements

General Safety

- All required traffic safety precautions should be complied with. All workers should wear required safety clothing. (Examples, and not limited to, include: high visibility vests, steel capped footwear and gloves).
- Only authorised trained personnel should operate any machinery. Where overhead machinery is used, care must be taken to avoid any overhead hazards.
- Before drilling or excavation, always ensure that the area is clear of underground services. (The appropriate service providers may need to be contacted).
- Avoid placing hands or fingers in and around moving machine parts when components are being lifted and manoeuvred into place.

System Safety Statements

- Take care when unloading the BG800 Gate components, as often there will be limited space to work with. Never go underneath a load that is being lifted.
- All installers must be careful when fitting gates, especially with the risk of a trapping injury occurring.



Installation Instructions

Preparation

The gate needs to be installed on a smooth and level surface that will allow the system to be opened and closed.

When installing the gate, it is good practise to start from one end and work towards the other, but always check total length measurements before anchoring. It is good practice to fully install the gate before anchoring to ensure correct fit and alignment.

To speed up installation time, it is recommended that as many BG800 Gate sections as possible, are pre-assembled before delivery to site. The quantity that can be pre-assembled is usually determined by the size of the vehicle used to deliver to site.

Before installing a BG800 Gate, ensure that all components required for the system are readily available and have been identified. BG800 Gate is a highly engineered safety device made up of relatively small number of parts. Before starting installation ensure that you are familiar with the design of the system.

The BG800 Gate ground conditions must meet or exceed the design specification.

Ensure that the area where the BG800 Gate is to be installed has enough space to work in and is flat enough so that the ground conditions will not impede installation. Minor site grading may be required.

Tools & Equipment

The tools required to install the BG800 Gate are:

- Suitable drilling equipment.
- Airline blower (for cleaning out anchor holes for resin fixings).
- Measuring tape and road marking equipment.
- Lifting chains – recommended 3m leg lengths, rated at 2 ton per leg with 1 one choke (not required if a forklift is used).
- Lifting equipment capable of lifting the BG800 Gate units. E.g. fork lift, crane, wheeled excavator, etc.
- $\frac{3}{4}$ inch drive socket suitable for the anchors – M24 Galvanised stud, washer & nut.
- $\frac{3}{4}$ inch drive ratchet
- $\frac{1}{2}$ inch drive ratchet, $\frac{1}{2}$ inch 24mm socket, $\frac{1}{2}$ inch drive 4 inch extension bar; used to raise/lower gate wheels.
- $\frac{1}{2}$ inch drive impact gun, $\frac{1}{2}$ inch drive 24mm double depth impact socket, compressor and pipe. Note: Not critical items but speeds up installation time.
- Spanner/Socket to remove inspection hatches (16mm & 17mm).
- $\frac{1}{2}$ inch torque wrench with 24mm socket (90-110Nm); for tightening M16 x 45 barrier bolts.
- $\frac{3}{4}$ inch torque wrench with 36mm socket (150Nm); for tightening M24 anchor studding if used.
- 2 off 50mm spacers; for setting hinge gaps.
- Large and small podger/pry bars.
- 6ft crow bar; useful for slight adjustments when lining up the barrier.

Installation

There are many variations of gate installations, depending on the BG800 Gate components used. The following installation shows the basic principles which vary little from the numerous models of gates designed to meet specific site requirements.

General drawing packs and/or project specific drawings give further information regarding exact gate design.

Note: Further installation advice can be sought from Highway Care International.

Step 01 - Measuring

Measure the space where the gate will be installed and mark the start and end point. Start the installation from one end of the gate assembly.

Step 02 - Assembly

Assemble the gate to the desired length according to the installation drawings. Ensure any wheels and anchor points are assembled in their correct positions.

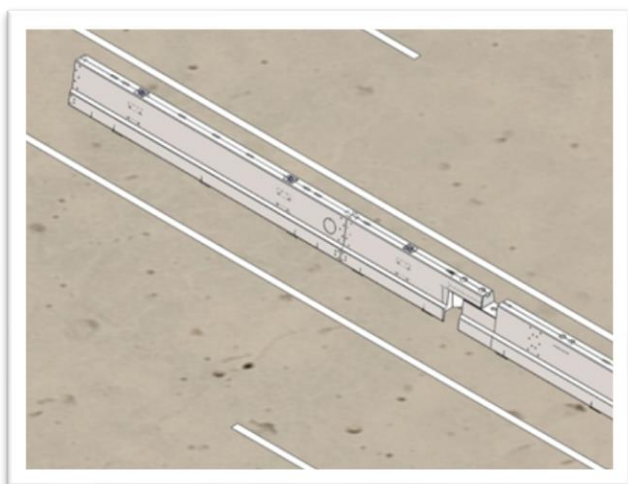
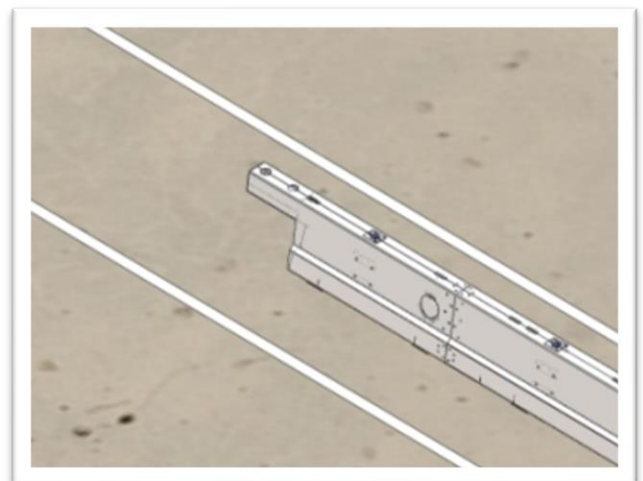
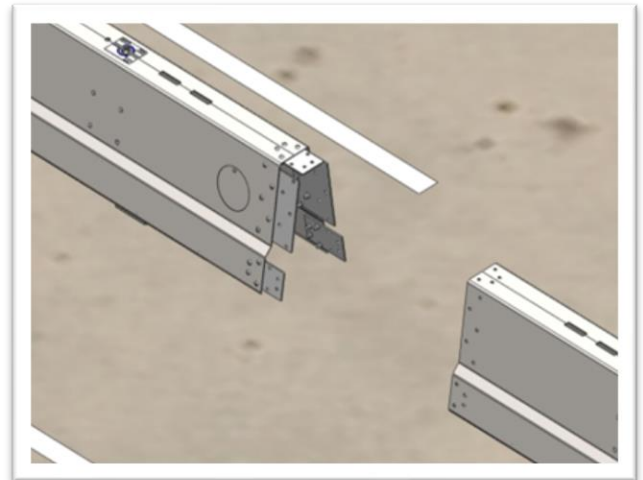

Step 03 – Position

Position the gate components in place (gate, hinge, gate posts). Ensure spacer and pins are in place. Lower the gate wheels when satisfied and make final adjustments.

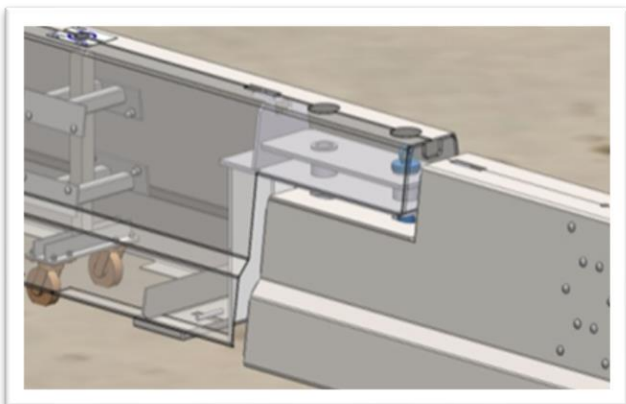
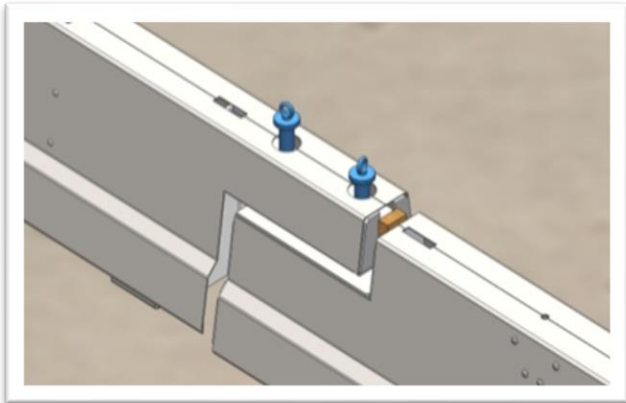
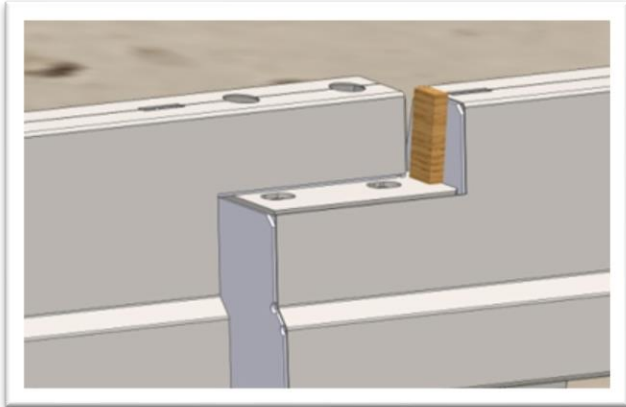

Note: Ensure the gate post and hinge edges are aligned smoothly.

Step 04 – Connection

Depending on the connection used, ensure this lines up with the barrier being attached. Adjust the gate/gate post position to best match the connection section. This can be done with a large pry bar or lifting equipment.

Step 05 – T-Top

If T-top is part of your gate design then install it aligned with the barrier away from where the gate post and hinge spacer gap is. Splice plates can be used to join T-top sections.

Note: It is recommended to leave the fixings loose in the T-top until after anchoring to the removable sections.

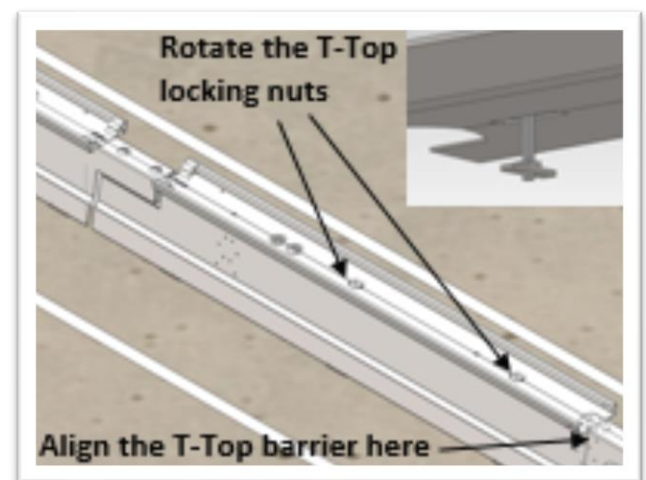
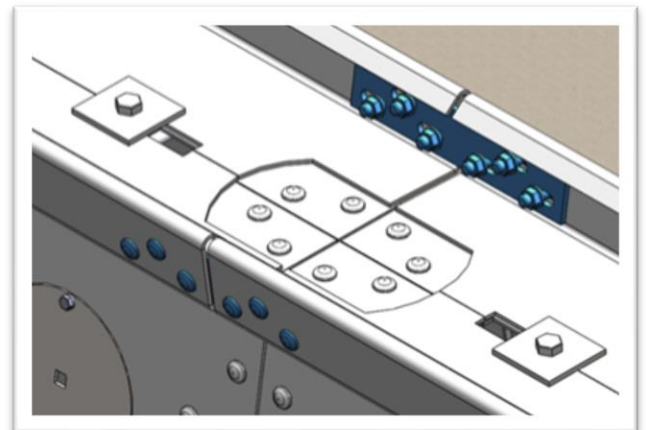

Install the removable T-top section, pins and turnbuckle. Do not tighten these components until ground anchoring is complete.

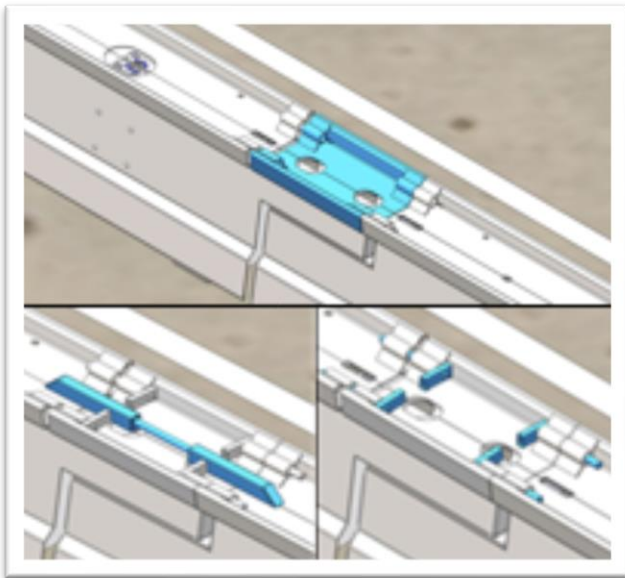

Note: If an internal anchor shoe is utilised it will be necessary to remove the barrier to allow the anchor to be drilled. Mark the anchor shoe position before removing the barrier.

Step 07 – System Check

Perform an operation check of the system to ensure usability.

Step 06 – Anchor

Ensure the gate is aligned with connections correctly and then drill and fit any ground anchors. The type will depend on the application and ground conditions of the gate.



Operation

Ensure appropriate Traffic Management is in place before operating the gate.

Remove weather cover if fitted.

Loosen the T-Top turn buckle on the hinge unit and remove. The spanner should be stored with the turn buckle.

Loosen the 4 off T-Top pins and fully remove; refit the nuts and washers to the pins to stop them getting lost.

Store the pins, turn-buckle and removable T-top panel inside the T-top of the gate post, so that it is ready for use when the gate is closed.

Now the gate post T-top section highlighted can be removed.

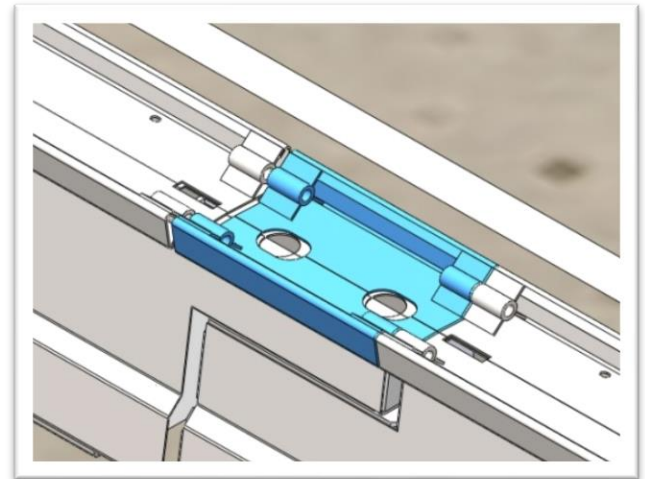
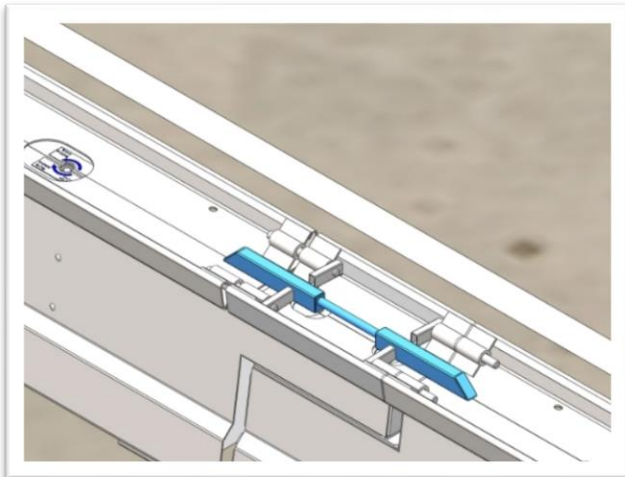

Repeat these operations for the other end of the gate post.

Use the correct socket for your gate (normally 24mm), a short extension (approximately 150mm is recommended) and a ratchet/ T bar or similar to lower all the wheel sets on the gate. Turn the socket anti-clockwise.

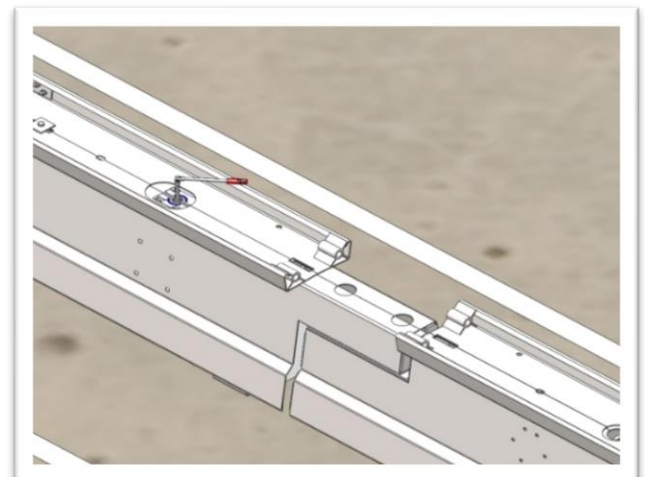
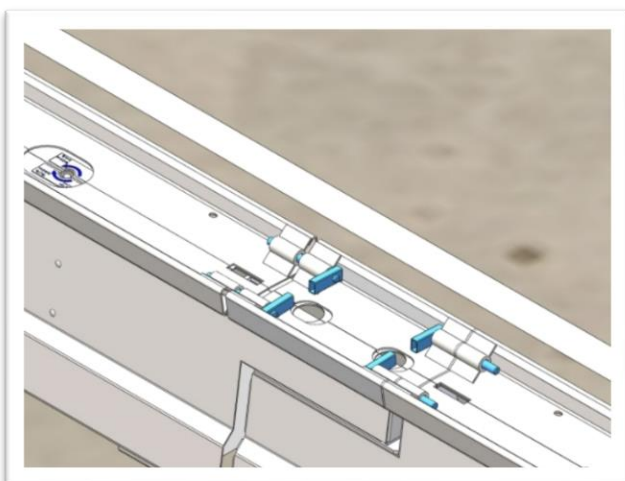

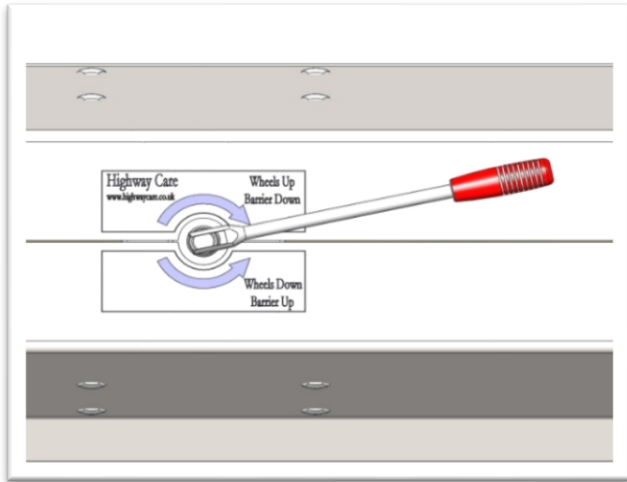

Lift and remove all 4 gate pins to fully disconnect the BG800 Gate. To hinge the gate, leave 1 pin inserted.

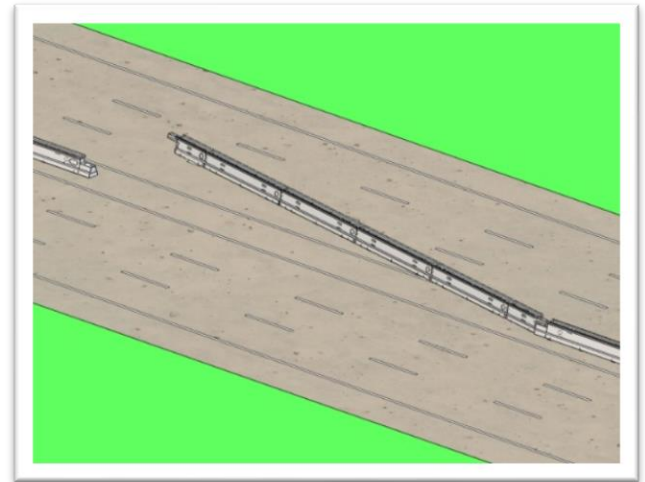

Reverse these steps to close the gate.

Maintenance & Repair

Maintenance

Highway Care International recommends that the BG800 Gates are opened at least once a year during routine maintenance programs. This provides the opportunity to grease/check the lifting jacks and jockey wheels operate correctly.

Repair

The BG800 Gate is a low maintenance system that is unlikely to be damaged after typical impacts, with just minor cosmetic damage the most common occurrence.

After more substantial impacts where a vehicle has significantly damaged the gate, it will be necessary to fully test the gates operation and also seek advice from Highway Care International regarding replacement gate components.

Ensure the galvanised coating is repaired if damaged.

Note: Further advice is available from Highway Care International where required.

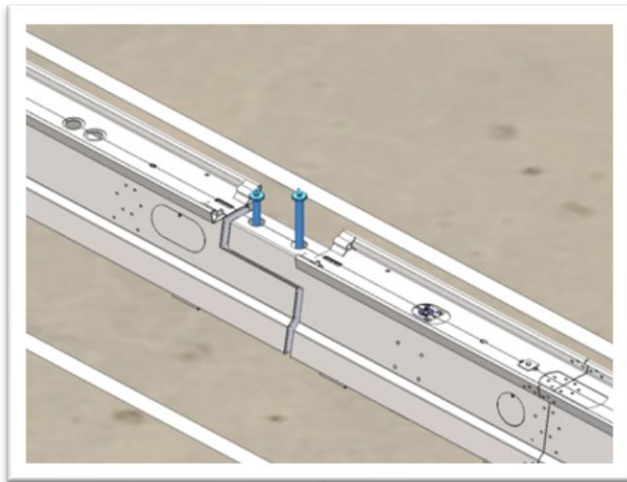

CAUTION: Once these pins are removed the gate is free to move.

Once the gate has been opened to the required position; use the socket, extension bar and ratchet to raise the wheels and lower the barrier.

Photo Examples



Thrie Beam Connection

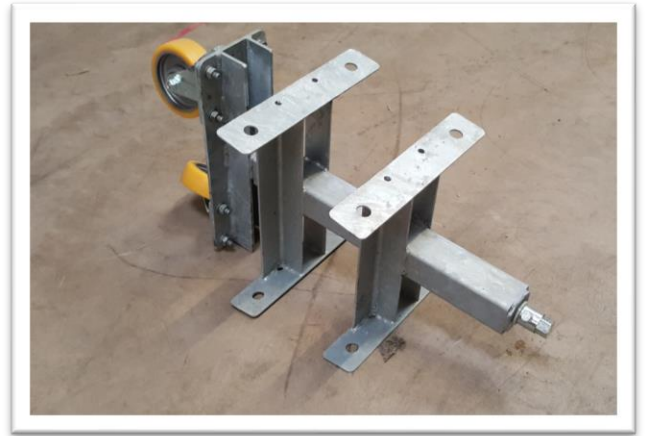

Wheel Set



T-Top Transition



Vehicle Passing Through Open Gate



Hinge Pin Being Removed



Hinge Joint

Frequently Asked Questions

1) What type of equipment is required to install BG800 Gate?

Suitable lifting equipment such as a hiab crane with hook lifting chains, marking and drilling equipment (e.g. Hilti or compressed air rock drill), various sockets and spanners up to 36mm, 6mm Allen key. Please refer to the *Tools and Equipment* section in this manual.

2) What ground conditions are required to install BG800 Gate?

Typical foundations are concrete and asphalt. Gradients need to be considered. The condition around the gate should be smooth paved and flat; free from debris to allow operation of the gate. Please refer to the *Design Consideration* section in this manual. Contact Highway Care International for further assistance.

3) What can the gate attach to?

There are connections to concrete, thrie beam, w-beam and BG800. Contact Highway Care International for further assistance.

4) Does the gate require anchoring when in a run of BG800?

It is recommended that the gate posts are anchored to ensure that when the gate is opened the BG800 upstream and downstream of the opening gap will still perform as tested.

5) On average, how long does it take to install BG800 Gate?

Depending on the application and circumstances at the site, experience of the workforce, equipment available, pre assemble taken place, once the ground conditions are suitable, installation and assembly on site should take approximately 2hrs.

6) What testing has BG800 Gate been approved to?

BG800 Gate has been tested and accepted to NCHRP 350 test level 3.

7) Can the gate be installed in any temperature/humidity environment?

BG800 Gate can be installed in the majority of environments, in some extreme environments enhanced components may be required. Contact Highway Care International for further assistance.

8) What maintenance does the BG800 Gate require?

BG800 Gate is a low maintenance gate that requires minimal upkeep. It is recommended that gate is opened and closed annually to ensure functioning operation.

Whilst BG800 Gate can be opened after a 'design' impact, it is recommended that any damaged components are replaced once opened.

9) What is the expected lifespan of BG800 Gate?

The gate has an expected lifespan of over 25 years. This is dependent on maintenance regime and site specific environment.

10) What is the smallest gate and largest gate available?

Standard metric gate lengths are 6m, 12m, 18m, 24m, 30m and 36m. These gate sizes provide openings of 4.67m, 10.67m, 16.67m, 22.67m, 28.67m and 34.67m respectively.

Bespoke opening sizes are available subject to application. Contact Highway Care International for further details.

11) How many people and how long does it take to open a gate?

A gate can be opened by two operatives in under 2mins.

12) Does the deflection change with different gate sizes?

The gate was tested as part of the BG800 family with a large anchor spacing. It is reasonable to expect based on standard BG800 testing that when the anchor spacing is reduced the tested deflection figure will also be lowered.

13) What opening angle can the gate achieved when hinged from one end?

A gate can be opened to in excess of 90 degrees when hinged from the rear pin on the gate post.

Appendix

Foundation Details

BG800 Gate can be installed in a range of pavement conditions and a variety of anchors are available to suit the pavement type.

Typical Pavement Material Specification

PORTLAND CEMENT CONCRETE (PPC)



Stone aggregate concrete mix, 4000 PSI [28MPa] minimum compressive strength (sampling per ASTM C31-84 or ASTM C42-84A, testing per ASTM C39-84) or similar.

ASPHALTIC CONCRETE (AC)



AR-4000 A.C. (Per ASTM D3381 '83) 0.75" [19mm] maximum, medium (type A or B) aggregate or similar.

Sieve Size	% Passing
1" [25mm]	100
3/4" [19mm]	95-100
3/8" [9.5mm]	65-80
No. 4	49-54
No. 8	36-40
No. 30	18-21
No. 200	3-8

COMPACTED SUBBASE (DGA)

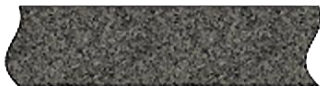

6IN. [150mm] minimum depth, 95% compaction, class 2 aggregate or similar.

Sieve Size	% Passing
3" [75mm]	100
2 1/2" [64mm]	90-100
No. 4	40-90
No. 200	0-25

Typical Pavement Construction Specifications

1) P.C. CONCRETE.



Foundation: Minimum 8 in. [200mm] reinforced PCC pad or 10 in [250mm] nonreinforced PCC pad.

2) ASPHALT OVER SUBBASE



Foundation: AC over compacted DGA subbase.

3) ASPHALT OVER P.C. CONCRETE



Foundation: AC over PCC

Typical Optional Foundation Pad Specification

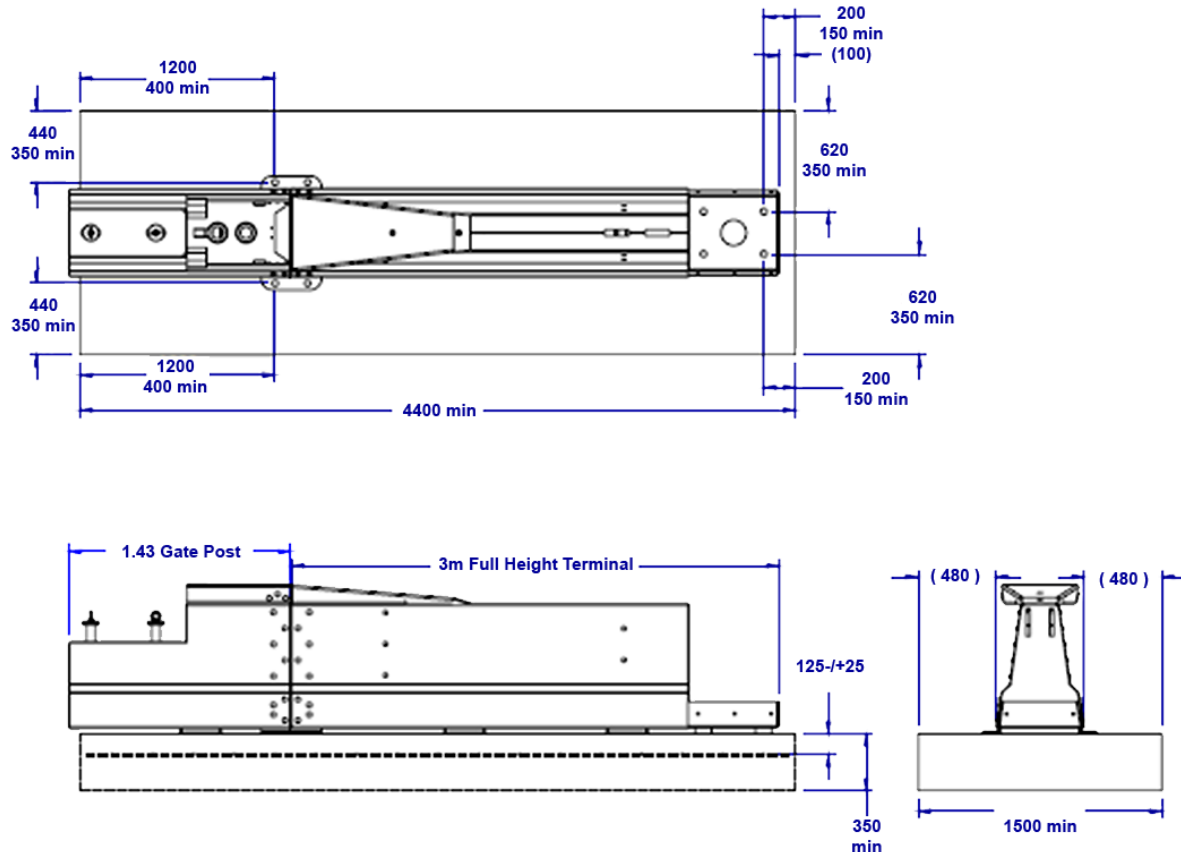

Foundation Pad Notes:

- 1) One layer of steel mesh A252 (BS 4483) or equivalent. Minimum Lap – 400mm. Minimum cover 50mm unless otherwise stated.
- 2) Mesh should be positioned so as not to conflict with anchor locations.
- 3) Minimum concrete grade strength at time of fixing C30. Poker vibration, surface finish – U2.
- 4) Slab surface to be level with surrounding surface levels.
- 5) Maximum recommended cross slope 2.5%. Back to front not to vary more than 2%.
- 6) All edges must be backfilled with aggregate sub base material (maximum size 20mm) and fully compacted.
- 7) Slab surface to be level with surrounding surface levels.
- 8) Minimum depth of slab – 350mm.
- 9) The area between the anchor pads and the swept arc of the gate movement should be smooth paved and flat to allow operation of gates. Also, consideration should be given to location of any road studs, drainage covers and access hatches.
- 10) The ground bearing resistance to be no less than 50kN / sq.m.

Anchor Installation Detail

Resin Anchor Studding

The steps below detail a typical resin anchor studding installation.

Note: Always follow the installation instructions supplied by the fixing manufacturer. These may differ to the guidelines below.

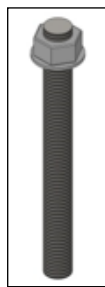

FATB-24-250-GLV

Note: this part No. does not include the resin

1. Drill a hole with a diameter of 28mm and a depth of 250mm.
2. Clean the hole using an air line and blow pipe or similar.
3. Mix the resin as specified by the manufacturer's specification.
4. Pour the required volume of resin into the hole; leave approximately 100mm without resin at the top of the hole as this may need to be increased or decreased to suit each application.
5. Position the anchor plate.
6. Fit the nut and washer to the anchor studding; leave approximately 2 full threads showing at the top of the studding.
7. Push the anchor stud into the hole to the required depth, the resin should reach the top of the hole, if not increase the quantity of resin.
8. Wait for the resin to cure as per manufacturer's specifications.
9. Tighten the anchor nuts to the manufacturer's specification.

Mechanical Anchor Bolt

The steps below detail a typical mechanical anchor bolt fixing installation.

Note: Always follow the installation instructions supplied by the fixing manufacturer. These may differ to the guidelines below.



FMA-24-185-YZ

1. Drill a hole with a diameter of 30mm and a depth of 250mm.
2. Clean out the hole using an air line and blow pipe or similar.
3. Insert the complete mechanical anchor into the hole.
4. Tighten the anchor to the manufacturer's specification.

Installation Checklist Example

BG800 Gate Installation Checklist			
Customer:			
Project:			
Checked By:			
Signed:			
Date:			
Is the site suitable for BG800 Gate? E.g. Is there enough space for the finished gate layout?	<input type="checkbox"/> Yes	<input type="checkbox"/> No	<input type="checkbox"/> N/A
Are the ground conditions suitable? E.g. No bumps/hollows/slopes that would significantly hinder the operation of the gate.	<input type="checkbox"/> Yes	<input type="checkbox"/> No	<input type="checkbox"/> N/A
Are all the components available?	<input type="checkbox"/> Yes	<input type="checkbox"/> No	<input type="checkbox"/> N/A
Do the anchor shoes have the lynch pin installed?	<input type="checkbox"/> Yes	<input type="checkbox"/> No	<input type="checkbox"/> N/A
Has T-top been installed?	<input type="checkbox"/> Yes	<input type="checkbox"/> No	<input type="checkbox"/> N/A
Are all 4 gate post to gate hinge pins installed?	<input type="checkbox"/> Yes	<input type="checkbox"/> No	<input type="checkbox"/> N/A
Are all the fixings torqued according to this document and/or manufacturer's instructions?	<input type="checkbox"/> Yes	<input type="checkbox"/> No	<input type="checkbox"/> N/A
Has the BG800 Gate operation been checked to ensure it is working?	<input type="checkbox"/> Yes	<input type="checkbox"/> No	<input type="checkbox"/> N/A
Has any minor damage to the galvanized coating been repaired using two coats of an organic zinc rich paint?	<input type="checkbox"/> Yes	<input type="checkbox"/> No	<input type="checkbox"/> N/A
Other information (serial numbers, reference drawings, installation notes)			

Approvals

Association	Approval Web Link
Austrroads	http://www.austrroads.com.au/road-construction/barrier-assessment

Country	State	Road Authority	Approval Web Link
Austrroads	New South Wales	Road & Maritime Services	http://www.rms.nsw.gov.au/business-industry/partners-suppliers/approved-products-materials/safety-barriers/index.html
	South Australia	Department of Planning, Transport and Infrastructure	http://www.dpti.sa.gov.au/standards/raod_safety_barriers
	Victoria	Vic Roads	https://www.vicroads.vic.gov.au/business-and-industry/technical-publications/technical-publications-a-to-z
	Queensland	Department of Transport and Main Roads	https://www.tmr.qld.gov.au/business-industry/Business-with-us/Approved-products-and-suppliers/Traffic-engineering-and-road-safety-approved-products.aspx
	Western Australia	Main Roads	https://www.mainroads.wa.gov.au/BUILDINGROADS/STANDARDSTECHNICAL/ROADANDTRAFFICENGINEERING/ROADSIDEITEMS/Pages/List_of_Approved_Road_Safety_Barrier_Systems.aspx#TOCh41
New Zealand	N/A	New Zealand Transport Agency	https://www.nzta.govt.nz/resources/road-safety-barrier-systems/



ENGINEERING YOUR SAFETY

WWW.HIGHWAYCARE.COM

Contact Details

Visit: www.highwaycare.com

Email: info@highwaycare.com

Call: +44 (0)1622 734215