



Product Manual



Release 09/24

www.ingalcivil.com.au

1.0 Introduction

Introducing Ezy-Guard 4, a member of the Ezy-Guard family, the next generation steel guardrail barrier providing superior motorist safety and more metres of barrier for your dollar.

Ezy-Guard 4 is crash tested to the latest performance standard distinguishing it from the existing Australian public domain guardrail barrier system.

The Z-post profile shields post edges from vulnerable road users and provides sectional strength when driving through difficult conditions.

An Ezy-Carriage is used to secure the w-beam rails to the posts eliminating the requirement for blocking pieces and rail stiffening plates. This unique connection provides a soft ride-down for the occupants and smooth vehicle containment and redirection.

2.0 Specifications

Ezy-Guard 4 Z-Post Length:	1,650mm
Ezy-Guard 4 Z-Post Mass:	12.5kg
Ezy-Guard 4 System Mass:	18.6kg per metre
Rail Height Above Ground:	787mm
Z-Post Height Above Ground:	777mm
Post Spacing:	2,000mm
Ezy-Guard 4 System Width:	200mm
MASH TL3 Crash Test Deflection:	1.57m

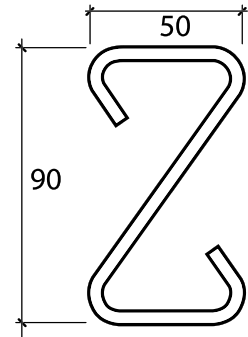

Ezy-Guard 4 rails and Z-posts are manufactured from hot-rolled steel flat products in accordance with AS/NZS 1594. These items are hot dip galvanised in accordance with AS/NZS 4680 after fabrication leaving no surface untreated.

Australian state specific product acceptance details are available upon request from your local Ingal representative. Acceptance conditions should be confirmed prior to installation.



3.0 Crash Test Analysis

Crash test guidelines provide a minimum set of requirements that a roadside barrier has to meet in order to demonstrate its satisfactory impact performance.

Whilst crash test guidelines cannot include all possible impact conditions that may be experienced in the real world, the crash test matrix is selected to represent a "worst practical condition" for a roadside barrier impact.

Ezy-Guard 4 has been fully crash tested and evaluated according to the specifications for Test Level 3 (TL3) of the AASHTO Manual for Assessing Safety Hardware (MASH).

The system has also been crash tested in accordance with NCHRP-350 Test Level 4, this is the containment of a 8000kg truck impacting the rail at 80km/h and 15°.

The MASH specification is an update to and supersedes NCHRP Report 350 for the purposes of evaluating new safety hardware devices.

The MASH TL3 crash test matrix requires the following impacts;

- 1100kg car travelling at 100km/h and 25 degrees.
- 2270kg pick-up travelling at 100km/h and 25 degrees.

Crash test impact conditions are defined by the mass, speed, and angle of the impacting vehicle. Crash test standards and performance levels can be compared by calculating the impact severity (IS).

$$IS = \frac{1}{2} M (V \sin \theta)^2$$

Where IS is the impact severity in joules (J), M is the test inertial mass of the vehicle in kilograms (kg), V is the impact speed in metres/second (m/s) and θ is the impact angle in degrees.

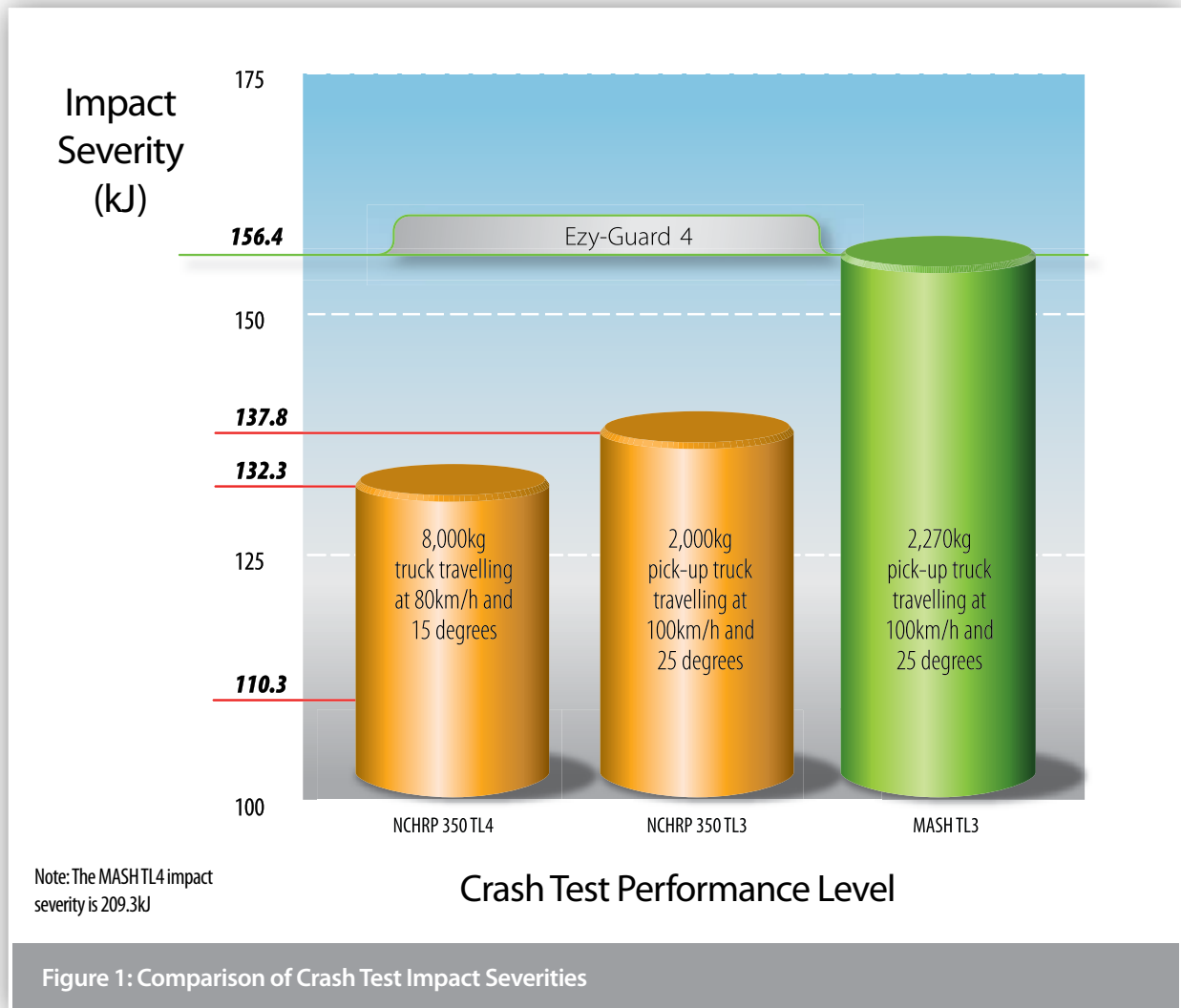

4.0 Consideration for Vulnerable Road Users

Vulnerable road users include motorcyclists, pedestrians, cyclists and other road users. Ezy-Guard 4 has been designed to provide consideration to vulnerable road users as follows:

Rounded Post Corners.

The Z-post contains smooth, rounded post edges and corners mitigating the risk and severity of fractures and/or contusions.

Energy Absorbing, Ductile Z-Posts.

The Z-posts are designed to yield by bending near ground level. This bending action absorbs impact energy reducing the potential for post fracturing. A fractured or split guardrail post presents a significant laceration hazard to vulnerable road users.

The Ezy-Guard 4 design does not contain any elements that become projectiles and there are no aggressive edges.

Shielded Posts.

The revolutionary design of Ezy-Guard 4 shields the top of the supporting Z-posts by positioning the top of the

rail above the posts. This eliminates dangerous snag points, reducing the potential for the barrier to dismount motorcyclists or cyclists. This is a significant safety benefit compared to all guardrail and cable barrier designs currently used within Australia.

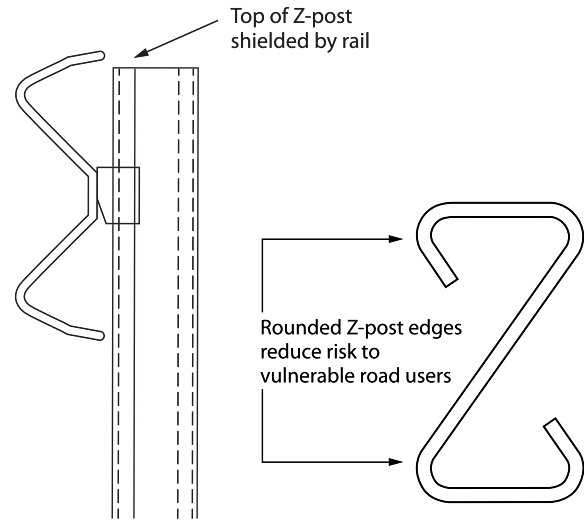

Figure 2: Ezy-Guard 4 Considerations for Vulnerable Road Users



5.0 Features and Benefits

5.1 Fully Compliant to MASH TL3 & NCHRP-350 TL4

Ezy-Guard 4, a member of the Ezy-Guard family, is fully compliant to MASH TL3 and NCHRP-350 TL4.

The MASH TL3 test condition represents a 13% increase in energy when compared to NCHRP 350 Test Level 3 impacts.

The NCHRP-350 TL4 compliance demonstrates the systems ability to contain and redirect the large 8000kg truck, which has a higher centre of gravity compared to the MASH TL3 pickup truck.

MASH TL3 COMPLIANT

NCHRP-350 TL4 COMPLIANT

5.2 Rapid Installation & Repair

Ezy-Guard 4 installation can be up to twice as fast to install than conventional guardrail barriers and unlike cable barrier systems, no concrete is required.

The Ezy-Guard 4 design uses fewer components and features 1,650mm Z-posts that are rapidly driven into the ground. The Z-post embedment depth is just 873mm, a significant reduction when compared to other guardrail posts. This reduces installation time providing significant cost savings.

Since the Z-posts are designed to yield by bending near ground level, damaged posts can be removed easily which reduces the time spent by work crews on the roadside.

5.3 Narrow Width

With a system width of just 200mm, Ezy-Guard 4 is significantly narrower than traditional guardrail barriers that incorporate the use of blocking pieces. Ezy-Guard 4 conserves valuable formation width and allows a greater recovery width to be provided for errant vehicles.

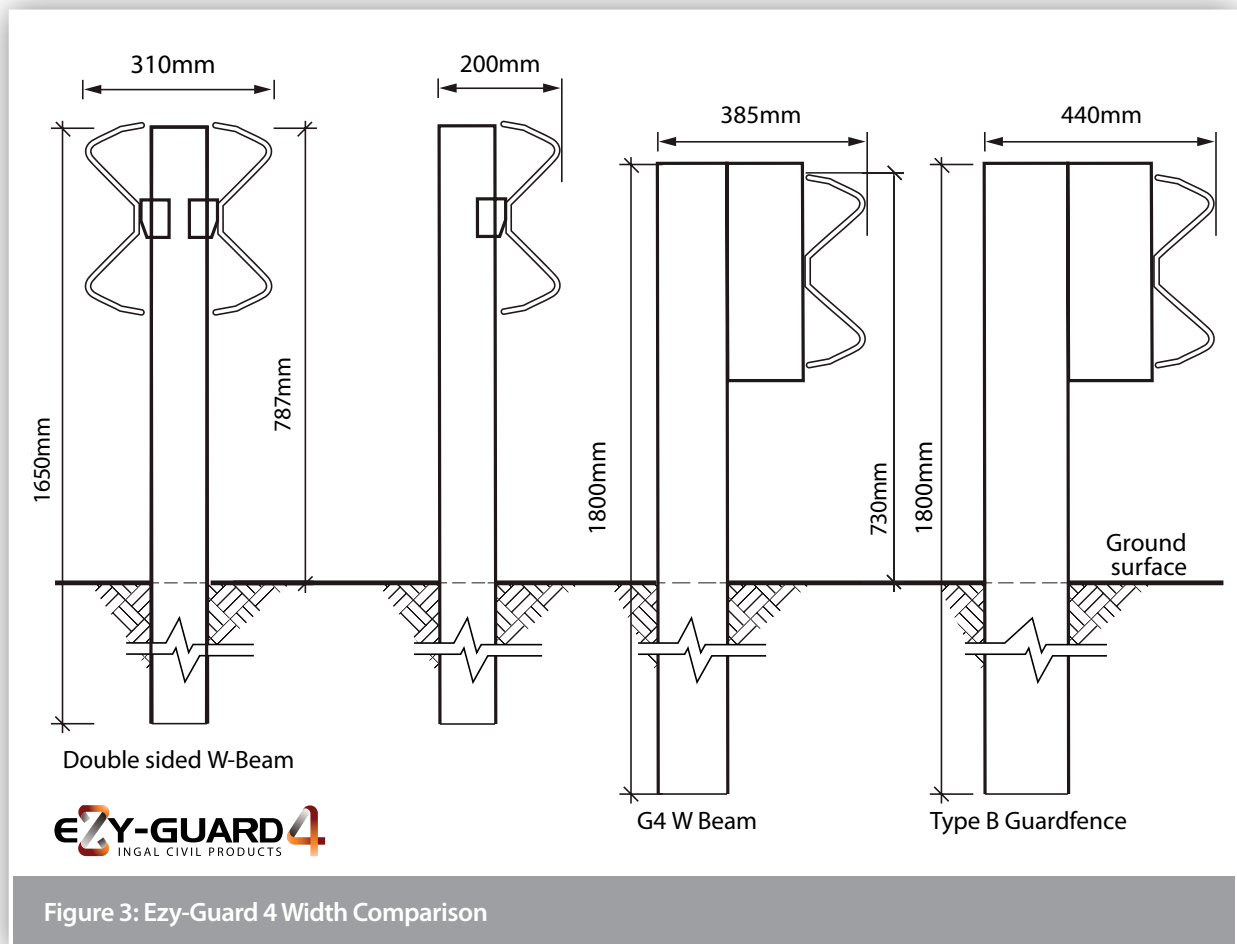

5.4 Installation in Rock, Asphalt or Concrete Mowing Strips

The design of the Z-post differs from traditional posts in that it relies on the yielding of the post by bending near ground level rather than the yielding of the surrounding soil during a vehicle impact. This makes the Z-post suitable for installation in rock, asphalt or concrete mowing strips.

A traditional guardrail post is designed to absorb some crash energy through post rotation in the soil prior to post failure. Restraining these traditional posts by setting them in narrow holes drilled into solid rock, by setting them in thick asphalt layers or concrete, or by placing a mowing strip around the posts can lead to a failure of the system to safely contain and redirect the errant vehicle.

5.5 Manual Handling

Ezy-Guard 4 uses fewer components than the public domain guardrail systems. Z-posts weighing just 12.3kg are 50% lighter than traditional C-posts. The lightweight Z-post reduces manual lifting by installation crews.

The rounded edges of the Z-post provides a handlelike grip when lifting, reducing the possibility of hand lacerations. The Z-profile allows the installer to maintain a firm grip and facilitates correct lifting techniques.

5.6 Locally Designed & Produced

Ezy-Guard 4 is manufactured in Australia by Ingal Civil Products using steel manufactured by BlueScope Steel. Z-posts and rail are stamped providing traceability to material mechanical and chemical analysis certificates. Hot dip galvanising is performed internally by Ingal and daily inspections ensure zinc thickness readings are in accordance with AS/NZS standards..

5.7 Soft Ride-Down Decelerations

The Ezy-Carriage controls the release of the w beam rail from the Z-posts. This controlled release reduces the potential for vehicle pocketing and provides a soft ridedown for vehicle occupants.



6.0 Performance

Ezy-Guard 4 provides protection from roadside hazards located close to the edge of the travelled way. The sectional strength of the 4 Z-post reduces lateral deflection whilst providing controlled containment and redirection.

Crash testing guidelines provide a set of requirements that is “worst practical conditions” in order to demonstrate the barriers impact performance. When the combined effects of vehicle mass, impact speed and angle of impact are considered, the testing criteria represents the extremes of impact conditions to be expected in real-world situations.

6.1 Deflection

The transverse deflection of a barrier during a crash is dependent upon the mass, speed, and impact angle of the errant vehicle.

Since crash testing typically represents the extremes of these parameters, a review of the proposed barrier location can be undertaken to assess the following;

- Maximum attainable impact angle;
- Design speed; and
- Design vehicle.

Figure 4 illustrates the vehicle trajectory when turned towards the barrier. The maximum attainable angle, ϕ is limited by the speed of the vehicle and the lateral offset, x to the barrier.

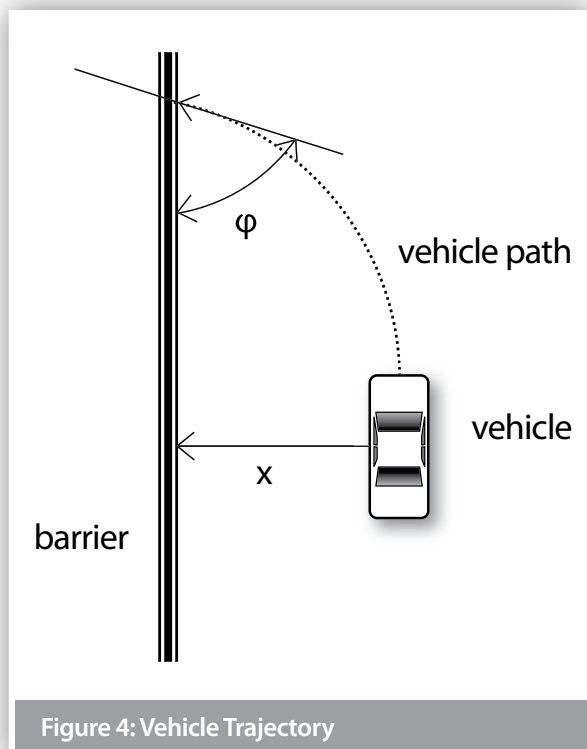

The maximum attainable angle for various speeds and offsets is shown in Figure 6 and is derived using a point mass model and assumes maximum steering and a coefficient of friction of 0.7 (dry pavement).

If the deflection needs to be reduced due to the proximity of a road side hazard, this can be achieved by reducing the post spacing. Refer to Tables 1a and 1b for deflections with reduced post spacing. The reduced post spacing should be initiated 8m upstream and returned to standard spacing 8m downstream of the hazard.

If designing for a containment level of TL4, designers should also consider the potential roll of the larger vehicle. Guidance on the calculation of roll allowance is detailed in the Austroads Guide to Road Design - Section 6.3.16. Refer Table 1b for NCHRP-350 TL4 deflection.

6.2 Slopes

The maximum cross fall for an installation of Ezy-Guard is 10H:1V (10%).

6.3 Batter Hinge Proximity

Installations of safety barriers in close proximity to a batter hinge point should be considered within the requirements of the road controlling authority Extended Design Domain.

Ezy-Guard Smart has been successfully crash tested to MASH TL3 with posts installed on the rounding point of a 2H:1V batter. The batter was comprised of AASHTO M147-65 Standard Soil.

Suitability of the ground conditions and/or erosion of the batter should be considered by the installation designer prior to installation of a safety barrier near a batter slope. It is recommended the barrier be installed with the maximum offset to hinge point possible. For NCHRP-350 TL4 containment, the offset to back of post should be 1.3m.

As the proximity of the batter slope may reduce the soil support to the post, the designer should also consider the use of an increased post embedment, refer section 7.5.2.



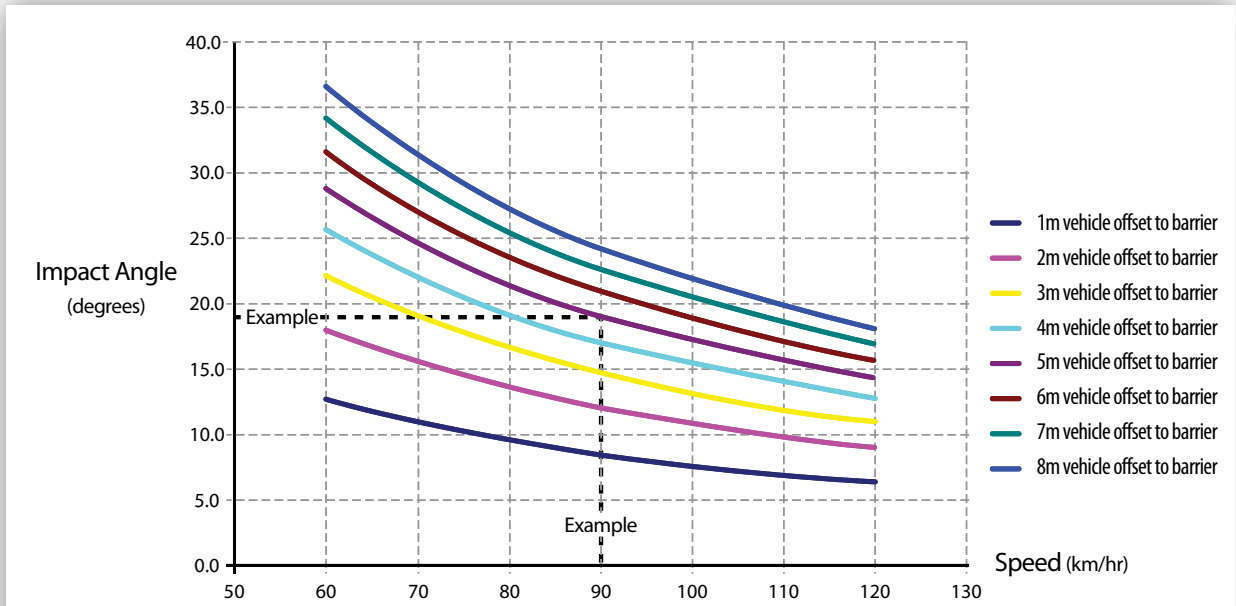

Figure 6: Maximum Attainable Angle by Speed and Offset.

Table 1a: MASH deflections for various post spacing and speeds

Containment Level		Speed (km/h)	Vehicle: 2,270 kg Impact Angle: 25°		
			Post Spacing (m)		
			2	1	0.5
Dynamic Deflection (m)	MASHTL3	100	1.57	1.05	0.73
	MASHTL2	70	0.9	0.57	0.4

Table 1b: Dynamic deflections for NCHRP-350 containment levels

Containment Level	TL2	TL3	TL4
Speed	70 km/h	100 km/h	80 km/h
Vehicle Mass	2,000 kg	2,000 kg	8,000 kg
Deflection	0.89m	1.46m	1.53m

Deflection result is based on full scale crash simulation, use of these deflection data requires road agency approval.



7.0 Installation

7.1 Terminals

Guardrail end terminals are designed to provide a soft gating impact preventing the end rail from spearing an impacting vehicle. Terminals also introduce tensile and flexural strength necessary to ensure redirection performance of the length-of-need section.

Ezy-Guard 4 is installed at a system height of 787mm, measured to the top of the rail. This height is compatible with our range of proprietary and public domain terminals, refer to installation drawings.

Departure terminals should only be installed if they are located outside the clear zone of approaching traffic. See Figure 7. The clear zone is the horizontal width of space available for the safe use of an errant vehicle.

The clear zone is dependant upon the speed of the vehicle. Guidelines are contained with regulatory publications.

Terminals should be installed in accordance with the proprietor's drawings and specifications. Z-posts are not to be used in the terminals unless approved by the proprietor.

The installation of terminals will typically incorporate the use of blocking pieces positioned between the posts and rail. This will require the supporting posts to be offset from the set-out line used for the installation of the Z-posts which do not require blocking pieces.

In addition, the post spacing used in the terminals and transitions may vary from the 2m spacing used for installation of Ezy-Guard 4. The required post spacing for terminals and transitions will be contained in the proprietor's drawings.

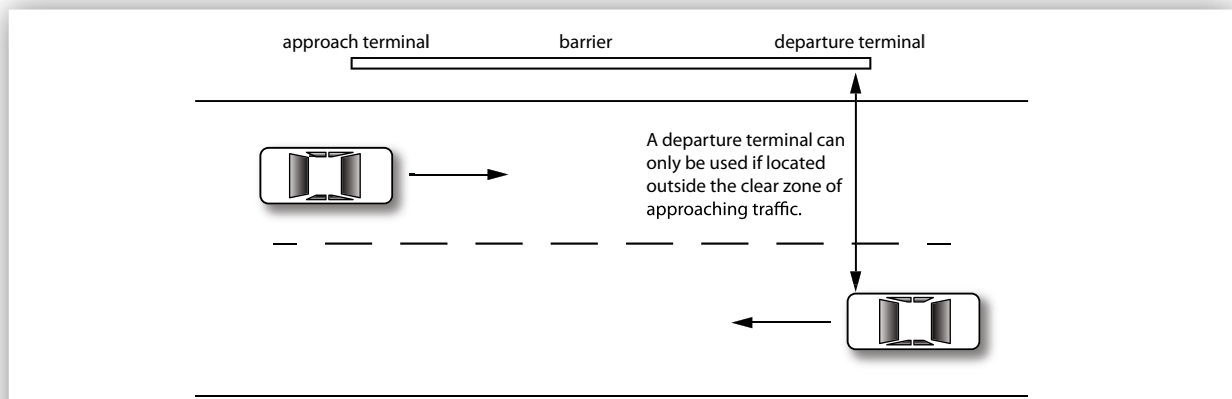

Figure 7: Clear Zone Requirement for the use of Departure Terminals



Figure 8: ET-SS Guardrail End Terminal

7.2 Minimum Length Requirements

There are two geometric methods used to determine the likely trajectory of a vehicle that leaves the road in the vicinity of a roadside hazard and the minimum length of barrier required to protect from this hazard. The most common method is the run-out length method and an alternative is a method based on angle of departure.

Prior to design or installation, designers should consult the relevant road controlling authority to establish the local jurisdictional practice as the methods may result in different lengths. Both methods are detailed in the Austroads Guide to Road Design – Part 6.3.

For instances where geometric constraints limit the installation of the recommended length under the above design methods, the absolute minimum length of minimum length of need for Ezy-Guard 4 is dependent on the design containment level.

- Test Level 2 containment, where the design vehicle is a 2,000kg pick-up, the minimum length of Ezy-Guard 4 between terminals is 12m.
- MASH Test Level 3 containment, where the design vehicle is a 2,270kg pick-up, the minimum length of Ezy-Guard 4 is 20m between terminals.
- NCHRP-350 Test Level 4 containment, where the design vehicle is a 8,000kg truck, the minimum length of Ezy-Guard 4 is 56m in between terminals

7.3 Sequence of Work

Where Ezy-Guard 4 is being constructed on a road open to traffic, it is recommended that the work commence at the end closest to the approaching traffic. Leading terminals and transitions shall be commissioned at the earliest practical time.

7.4 Modifications

Ezy-Guard 4 shall be constructed in the configuration as detailed in Ingal Civil Products' drawings. This is the configuration in which the system has been crash tested. No modifications shall be made to the system unless verified by Ingal Civil Products.

Flame cutting of rails or posts is not permitted. Saw cutting and drilling is permitted in the event that a post is to be installed at an irregular spacing and/or rock is encountered and the post embedment depth has been modified in accordance with Table 4.

Any modification carried out after fabrication will require repair to the galvanized coating. This is undertaken by applying two coats of an organic zinc rich epoxy paint complying with AS/NZS 3750.9. This is to be applied to the repair areas in two coats. Each coat shall have a minimum dry film thickness of 50 µm

7.5 Soil Requirements & Embedment Depth

The Z-post is designed to yield by bending near ground level during impact. Provided the post is embedded in material that allows this failure mechanism to be replicated, the Ezy-Guard 4 functionality will be retained. The Z-posts will provide lateral resistance until the impacting vehicle causes deformation of the posts. At this point the Ezy-Carriages will provide a controlled release of the rail from the Z-posts resulting in safe vehicle containment and redirection.

7.5.1 Standard Soil

Ezy-Guard 4 has been evaluated for installation in standard soil in accordance with AASHTO standard specifications for 'Materials for Aggregate and Soil Aggregate Subbase, Base and Surface Courses,' designation M 147.

When installed in standard soil, the 873mm embedment depth of the Z-post is sufficient for installation up to the rounding point on 2:1 embankment slopes.

Installations within 300mm from the hinge point should be considered within the requirements of Section 6.3 and the road controlling authority Extended Design Domain requirements.

7.5.2 Weak Soil

Ezy-Guard 4 has been evaluated for installation in weak soil in accordance with AASHTO standard specification for 'Fine Aggregate for Hydraulic Cement Concrete,' designation M 6.

When installed in weak soil, the 873mm embedment depth of the Z-post is sufficient for installation up to 500mm of the rounding point on 2:1 embankment slopes. If installation is required within 500mm of the rounding point, the post embedment depth is required to be increased to 1,050mm. A longer Z-post is available from Ingal for these applications. Installations in close proximity to a batter slope should be in accordance with Section 6.3 and the road controlling authority extended design domain requirements..



7.6 Post Pullover Test

In the event that the soil type cannot be verified, the suitability of the post foundation can be established through a post pullover test.

This is undertaken by applying a 1kN load to the post, 550mm above ground level. The load is applied prior to the attachment of the rail. Displacement at the base of the post shall not exceed 1mm whilst the load is applied.

An alternative post pull over test can be achieved via a more destructive means, whereby a load of 1.2 tonnes is applied to the test post at a height of 700mm. This loading approximates the probable capacity of the post and should be able to be maintained with minimal rotation of the post in the soil. At the completion of the testing the post should be removed from the test location and should not be used in the installation.

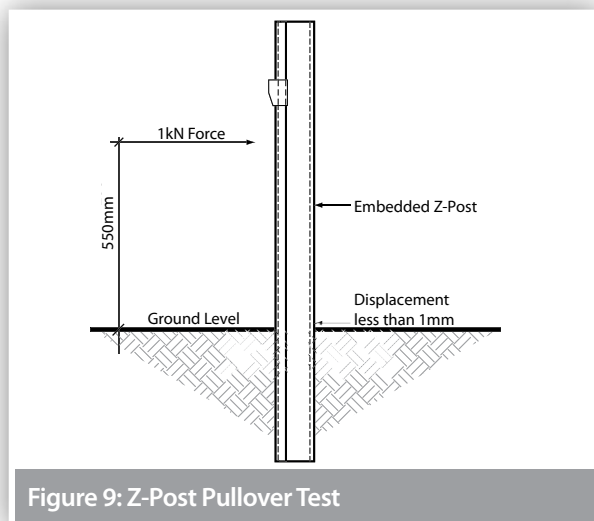

Figure 9: Z-Post Pullover Test

7.7 Posts on Base Plates

In the event that the Z-post cannot be installed to the required in-ground depth, the use of a base plate

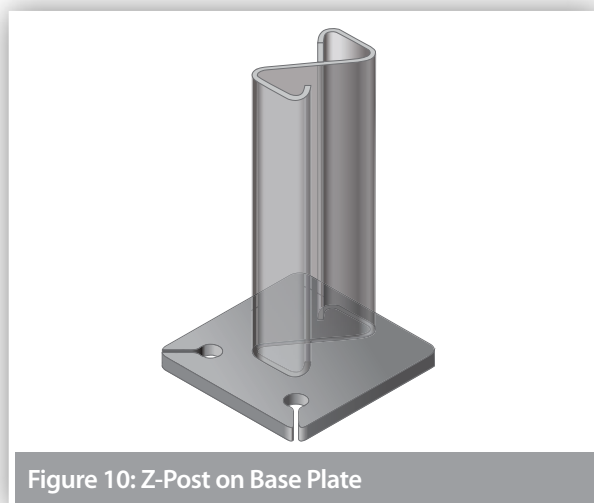

Figure 10: Z-Post on Base Plate

mounted on a suitable foundation can be adopted. Posts on base plates are typically used at culvert locations, and in areas where underground services restrict posts from being driven into the ground. Refer to Ingal Civil Products drawings for the installation of posts on base plates.

7.8 Z-Posts in Rock

Traditional guardrail posts are designed to yield in the surrounding soil and their placement in rock or concrete is problematic. Restraining the traditional posts by setting them in narrow holes drilled into rock, setting them in concrete or placing a mowing strip around the posts can lead to a failure of the system to safely contain and redirect the errant vehicle.

The specially engineered Z-post dissipates energy by yielding through bending near ground level. This means that typical recommendations for the installation of a traditional guardrail post in rock are not applicable to the Z-post. When rock is encountered, the installation guidelines as detailed in Table 4 are applied. If required the post may be cut onsite by a disc grinder or equivalent steel cutting tool. A corrosion resistant treatment will need to be applied to the freshly cut surface, ICP recommend a Zinc metal spray in accordance with ISO 2063 or AS/NZS 2312.

7.9 Non-Standard Post Spacing

Occasionally, a roadside hazard may prevent a post from being installed at the recommended spacing. In these instances it may be possible to stiffen the barrier with reduced post spacing on the approach and trailing side of the hazard, we would recommend you discuss these options with your local Ingal Civil Products representative. Approval may be required from the relevant road authority.

7.10 Delineation

A specially designed delineator may be attached to the Z-post. Typically, delineation is arranged so that drivers approaching from either direction will see only;

- Red retro-reflectors on their left;
- White retro-reflectors on their right on two-way carriageways; and
- Yellow retro-reflectors on their right on one-way carriageways and medians separating traffic in opposing directions

The spacing of delineators is dependant upon driver line of sight. As a general rule delineators are provided for installation every 20m on straight alignments and may be closer on curves, depending on the radius. Refer Road Authority specs.

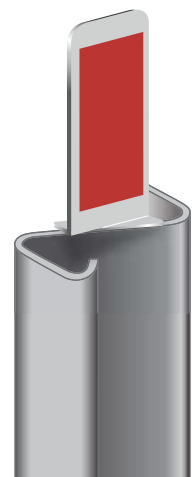
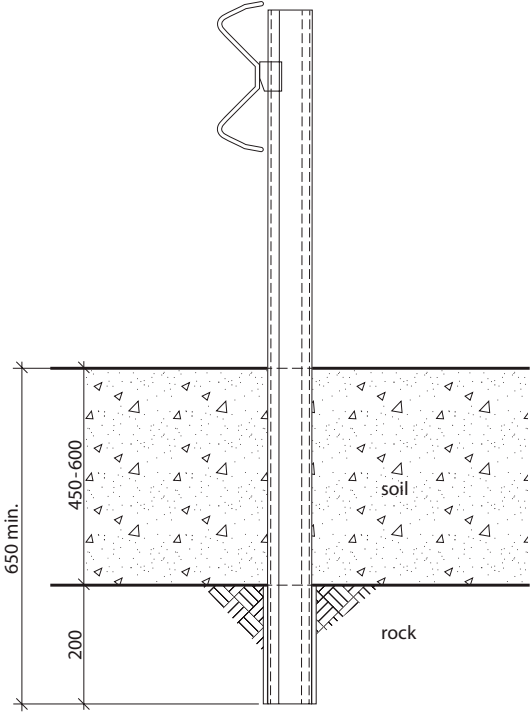
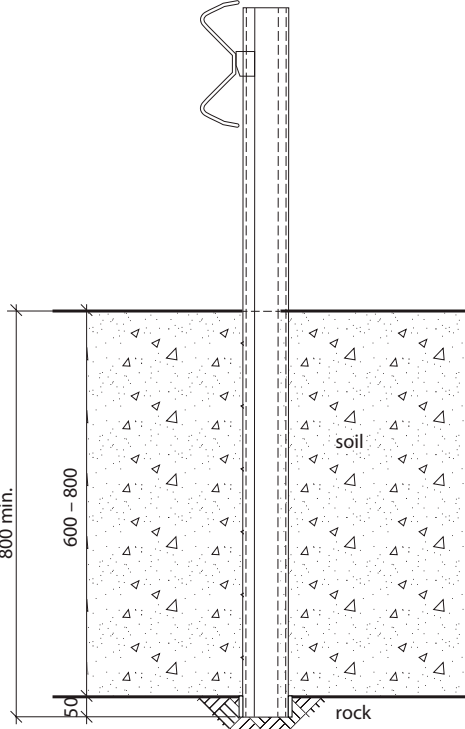

Table 4: Installation of Ezy-Guard 4 Z-Posts in Rock

Site Condition	Installation Requirements	
<p>Rock is encountered at the surface.</p>	<p>Drill a 110-300mm diameter hole to a depth of 450mm, install the post in the hole and backfill.</p>	
<p>Rock is encountered within 450mm of the surface.</p>	<p>Drill a 110-300mm diameter hole 450mm into the rock or to a minimum total post embedment depth of 650mm, whichever comes first, install the post and backfill.</p>	

Site Condition	Installation Requirements	
<p>Rock is encountered 450mm to 600mm below ground.</p>	<p>Drill a 110-300mm diameter hole 200mm into the rock or to a minimum total post embedment depth of 650mm, whichever comes first, install the post and backfill.</p>	 <p>The diagram shows a vertical post with a hook at the top. The post is embedded into a rock layer. A dimension line on the left indicates a total embedment depth of 650 mm minimum. The hole is filled with soil, and the backfill depth is indicated as 450-600 mm. The rock layer is shown below the soil.</p>
<p>Rock is encountered 600mm to 800mm below ground.</p>	<p>Drill a 110-300mm diameter hole 50mm into the rock or to a minimum total post embedment depth of 800mm, whichever comes first, and install the post and backfill.</p>	 <p>The diagram shows a vertical post with a hook at the top. The post is embedded into a rock layer. A dimension line on the left indicates a total embedment depth of 800 mm minimum. The hole is filled with soil, and the backfill depth is indicated as 600-800 mm. The rock layer is shown below the soil.</p>

7.11 Curving of Rails

Guardrail used for the assembly of Ezy-Guard 4 may be shop curved to fit any radius from 2.4m to 45m Convex.

Ezy-Guard 4 for Concave Curves can be used from 2.4m to 45m. Curves in excess of 45m do not require shop curving as the rail can be field installed to suit. Guardrail may be curved either concave or convex to the traffic face and can be part-curved along its length to suit site requirements.

7.11.1 Measuring Curvature

1. Mark along the arc of the curve at 4m intervals.
2. Measure the corresponding chord length (C) - refer to Figure 11.
3. Measure the corresponding centre offset (H) - refer to Figure 11.
4. Use the values for C & H to select the radius from Table 5.
5. Determine the curvature orientation from Figure 12.

7.11.2 Identification of Curved Rails

Where a rail has been factory curved by Ingal, the radius of curvature is marked on the rear face of the rail.

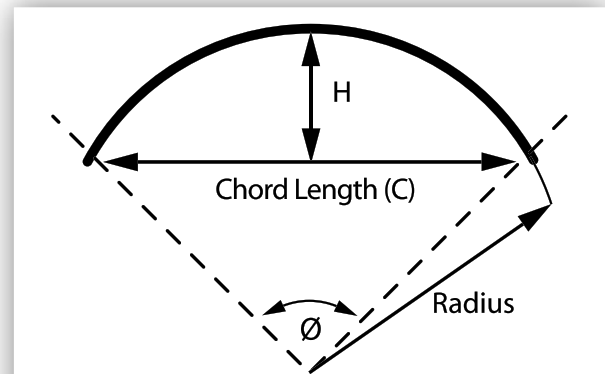

Figure 11: Curvature Measurements

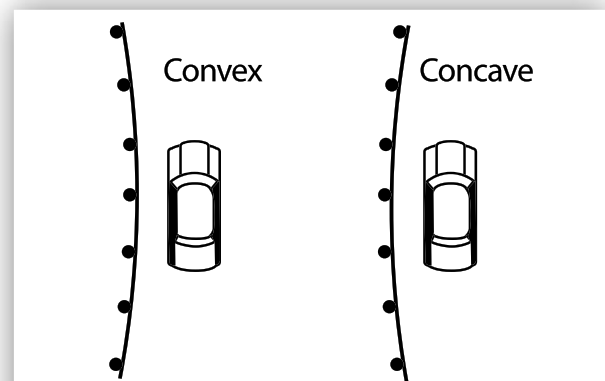

Figure 12: Curvature Orientation

Table 5: Rail Curvature Values

Radius (m)	∅ Degrees	C (mm)	H (mm)
2.4	95	3553	786
3	76	3710	642
4	57	3835	490
5	45	3894	395
6	28	3926	330
7	33	3946	284
8	29	3958	249
9	26	3967	221
10	23	3973	199
12	19	3982	166
14	16	3986	143
16	15	3990	125
20	12	3993	100
24	10	3995	83
28	8	3997	71
32	7	3997	62
35	7	3998	57
40	5	3998	50
45	5	3999	44

7.12 Barrier Offset From Kerb

The presence of kerbs in close proximity to a safety barrier, combined with the vehicle speed and kerb profile can dramatically influence the way an errant vehicle engages and interacts with the safety barrier. Extensive guidance on this topic is given in the Austroads Guide to Road Design Part 6, including the suitability of kerb profiles for various offsets and speeds.

As a general principle, it is preferable that surface conditions in front of and beneath a safety barrier should be relatively flat. Where this is not possible due the presence of a semi-mountable kerb and a barrier has been deemed appropriate, it is recommended the Ezy-Guard 4 system should be installed with its height measured from back of kerb, i.e. 790mm to top of W-Beam.

7.13 Installation Sequence

The following written instructions should be read in conjunction with Ingal Civil Products' drawings.

A generic Safe Work Method Statement is available from Ingal Civil Products to assist in the safe installation of Ezy-Guard 4. Suitable traffic control should be in place before any works.

Only items purchased from Ingal Civil Products shall be used for the construction of Ezy-Guard 4.

1. Ensure the area has been inspected for underground hazards and where a service clash has been identified, the barrier should be adjusted longitudinally if possible.
2. Post locations are marked ensuring any fixed object hazard is located outside the expected dynamic deflection of the barrier.
3. The post lugs are to be at the top of the post and facing the traffic as per Figure 13 and 14.

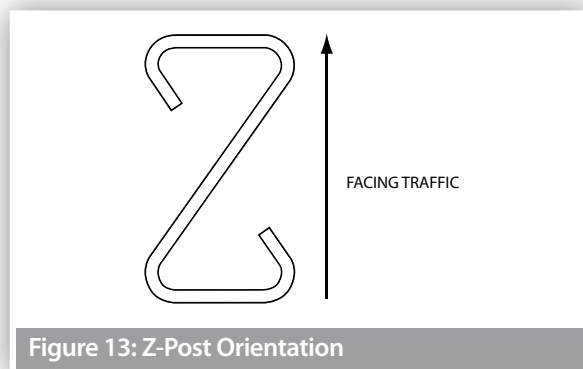

Figure 13: Z-Post Orientation

4. Posts are driven directly into the ground and should be vertical. The post installation process shall not cause damage to the post, such that it reduces the effective operation of the safety barrier or its design life, or introduces sharp tearing edges, nor shall it cause damage to pavement. If the Ezy-Carriage cannot freely move as it is attached to the post as a result of deformation of the post during installation, then the post shall be replaced.

The use of a vibrating post hammer will reduce deformation to the top of the post and install the post at a controlled rate.

5. Alternate to driving the posts, a minimum 110-300mm hole can be augured and the post placed in the hole. The posthole is then backfilled with the material that was excavated. If installing in soil, the material should be placed in layers of 150mm and suitably compacted to not less than the density of the surrounding layers.
6. Posts are spaced at 2m – Lesser spacings are required on transitions to Thriebeam, and where requested by an engineer.

7. The height of the Z-post above ground level is 777mm.
8. The Ezy-Carriage is attached to the face of the post. The Ezy-Carriage will come to rest on the positioning lug fabricated on the Z-post.

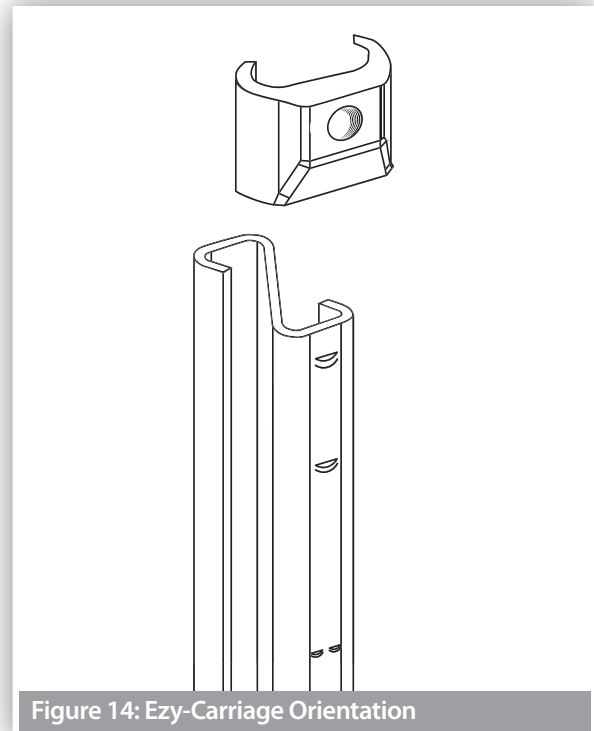

Figure 14: Ezy-Carriage Orientation

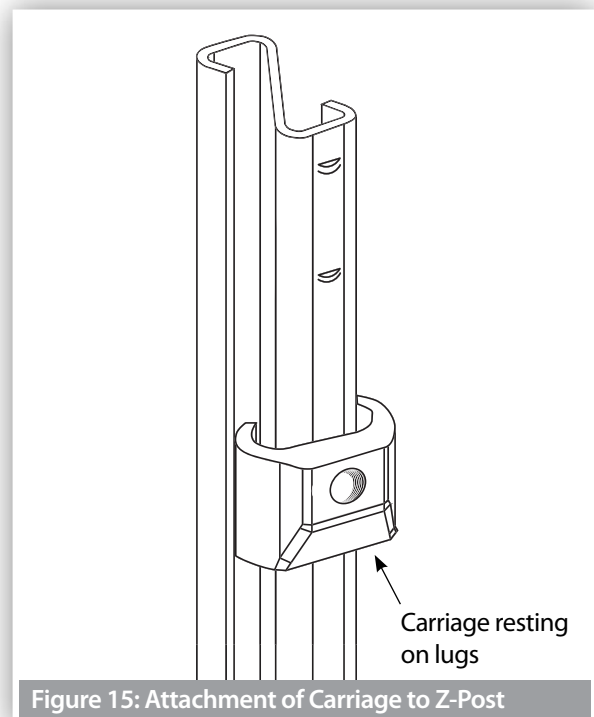
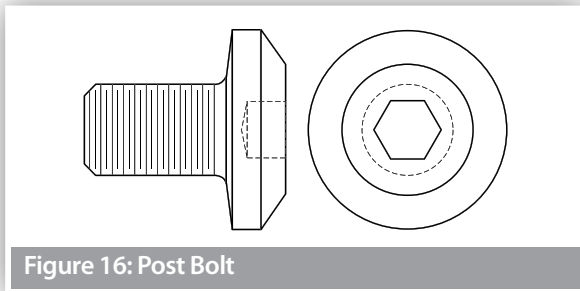
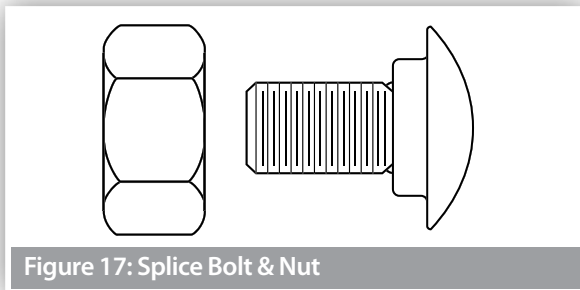

Figure 15: Attachment of Carriage to Z-Post

- Rails are attached to the Ezy-Carriage using the M16x30mm post bolts. The post bolts are identified by the socket recess located in the head of the bolt. The bolts are tightened to snug tight using a 10mm hex. key.



- Rails are spliced together at every second post using M16x32mm mushroom head bolts and oversized nuts. There are 8 bolts required per splice connection. A pinch bar may be used to assist in the alignment of splice holes. The use of a driving pin to elongate the slots is NOT to be used since this may cause tearing of the rail at the slot location. The bolts are tightened to snug tight.



- Rails are orientated so that no leading edge is presented to the traffic face as shown in Figure 18.

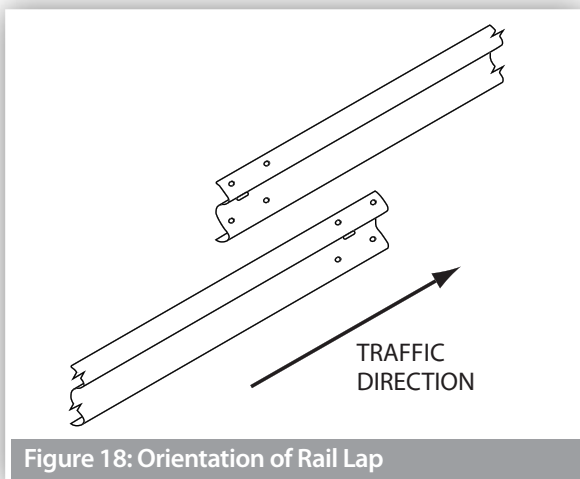

- It is recommended that posts be installed only a few metres ahead of rail assembly to ensure correct post spacing and alignment. On curves, the rails can be used as a template and laid on the ground to determine post locations.
- Where possible, the barrier should form a smooth line vertically and horizontally when viewed along the line of the system, free from humps, sags or other irregularities..
- The Ezy-Guard 4 components are to be free from splits, burrs or sharp edges after installation. Any minor damage to the galvanise coating is to be repaired by applying two coats of an organic zinc rich paint.
- Any disturbed pavement or material around a post shall be left dense, tight, and smooth so that resistance to water penetration is similar to that of the adjacent surface.

7.14 Back to Back W-Beam Installation

The Ezy-Guard 4 system can also be used in median applications where the W-Beam is installed on both sides of the post. This configuration requires a special post with resistance tabs on both sides of the post. The installation procedure is the same as for a single sided installation with steps 8 thru 15 repeated on the opposite side of the post. Refer drawing Ezy-SM-035 for further assembly detail.

7.15 Installation Tolerances

- The tolerance on height of the barrier shall be +25mm/-50mm for a MASH TL3 containment level. For an NCHRP-350 TL4 containment level the height shall be within +25mm/-0mm.
- The tolerance for the line of the barrier shall be plus or minus 20mm in plan view.
- The tolerance for departure from the upright axis shall be plus or minus 15mm at the top of the barrier.
- The tolerance on post spacing shall be plus or minus 25mm.

8.0 Maintenance

8.1 Preventative Maintenance

It is recommended that annual inspections be performed to ensure the following;

- The system is appropriately delineated;
- Debris has not accumulated around the system that may impede the performance of the barrier or the trajectory of an impacting vehicle;
- The system is suitably anchored with appropriate terminals and/or transitions. If the system is anchored with terminals, the cable assembly shall be taut and tensioned to its recommended value; and
- All splice bolts and post bolts are snug tight.

8.2 Ezy-Lift for Maintenance Overlays

For existing Ezy-Guard installations where the road surface has been overlaid or resurfaced, resulting in the barrier height being outside of the installation tolerance, the Ezy-Lift carriage is available to bring the W-Beam back to the appropriate height. The carriage gives the option to lift the W-Beam by +50, +100, +150 and +180mm. Refer assembly drawing EZY-SM-137 for further detail.

Installation sequence:

1. Unbolt M16x32 Splice Bolts at splice joint at either end of W-Beam rail.
2. Unbolt each carriage bolt on W-Beam rail. Exercise caution on removal of carriage bolts as rail will be unsupported after removal and may fall to the ground.
3. Lay W-Beam on ground adjacent to original position.
4. Remove carriage from post and replace with Ezy-Lift Carriage.
5. Reinstall carriage bolt and M16 washer into lowest hole in carriage and tighten to snug tight using a 10mm hex key. Refer to Detail A on drawing.
6. Repeat steps 1 through 5 until required W-Beam rail has been disassembled.
7. Determine the required lift by measuring the height of overlay. The nominal W-Beam height of Ezy-Guard Smart is 730mm.

8. Rails are to be re-attached to the Ezy-Lift carriage using a M16x30mm post bolts and 75x45mm rectangular washer at each post.
9. Rails are overlapped so that no leading edge is presented to the traffic face as shown in Figure 18.
10. Rails are spliced together at every second post using M16x32mm splice bolts and oversized nuts. There are 8 bolts required per splice connection. A pinch bar may be used to assist in the alignment of splice holes. The use of a driving pin to elongate the slots is NOT to be used since this may cause tearing of the rail at the slot location. The bolts are tightened to snug tight.

9.0 Product Storage

All posts and rails are hot dip galvanized in accordance with AS/NZS 4680. It is important that stored galvanized work is stacked so that each item is well ventilated and can adequately drain rainwater from its surfaces.

Poor storage can give rise to wet storage stain (white rust) which is caused by water (rain or condensation) in badly drained or ventilated conditions. This can occur very quickly, particularly in warm, humid conditions.



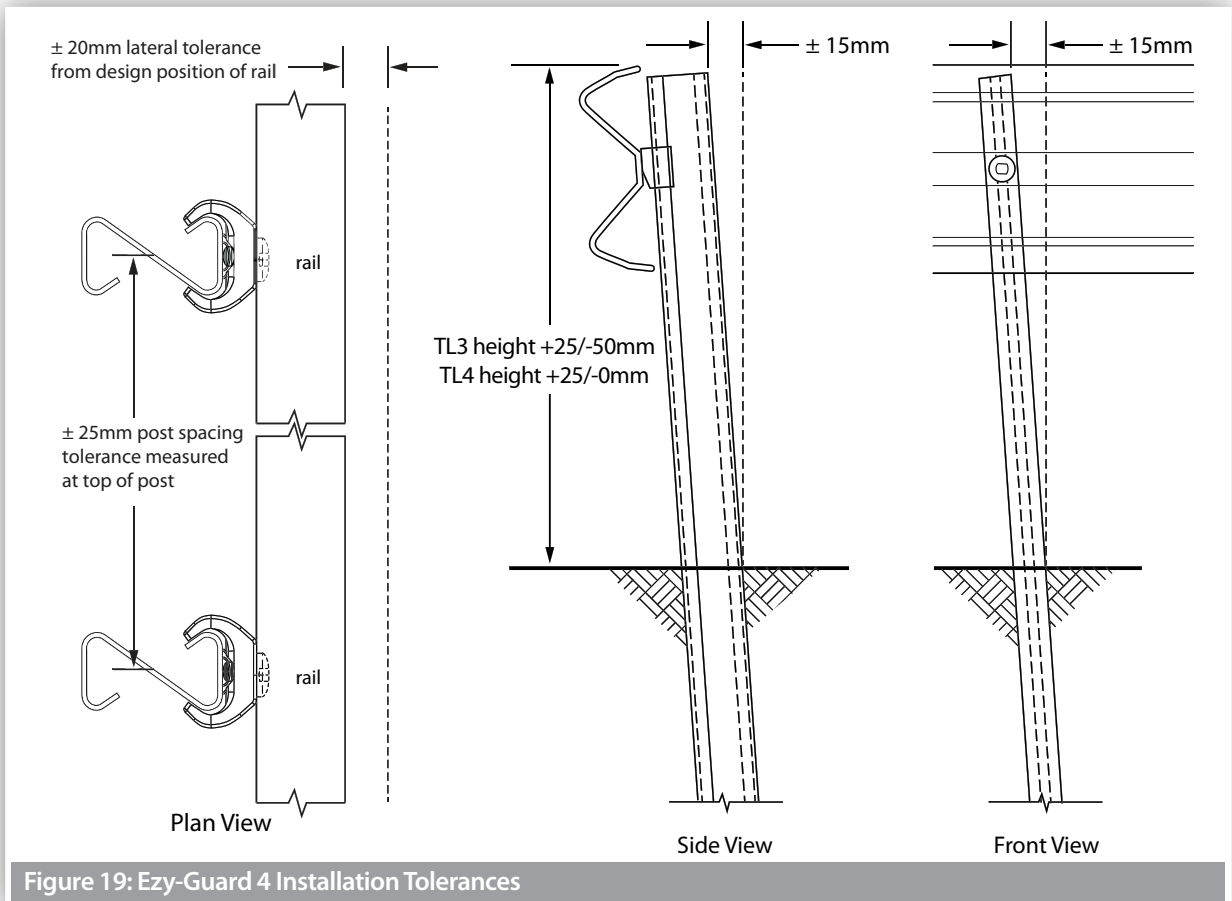

Figure 19: Ezy-Guard 4 Installation Tolerances

Ezy-Guard 4 Installation Checklist

 Customer:

 Project:

 Barrier ID:

 Barrier Length:

 Checked By:

 Signed:

 Date

Have the Z-posts been positioned every 2m	<input type="checkbox"/> Yes	<input type="checkbox"/> No
Have the Z-posts been correctly orientated in relation to the direction of traffic	<input type="checkbox"/> Yes	<input type="checkbox"/> No
Carriages are positioned on the posts between the retaining lugs and the resistance tabs	<input type="checkbox"/> Yes	<input type="checkbox"/> No
Posts are installed to the correct height (777mm) and within the tolerances of section 7.14	<input type="checkbox"/> Yes	<input type="checkbox"/> No
Have the Ezy-Carriages been correctly orientated	<input type="checkbox"/> Yes	<input type="checkbox"/> No
Have the rails been attached to the Ezy-Carriages using the post bolts with the socket recess	<input type="checkbox"/> Yes	<input type="checkbox"/> No
Have the rails been spliced observing the correct lap	<input type="checkbox"/> Yes	<input type="checkbox"/> No
Have the rails been spliced with M16x32mm mushroom head bolts	<input type="checkbox"/> Yes	<input type="checkbox"/> No
Are all splice bolts and post bolts snug tight	<input type="checkbox"/> Yes	<input type="checkbox"/> No
Is Ezy-Guard 4 appropriately delineated	<input type="checkbox"/> Yes	<input type="checkbox"/> No
Is Ezy-Guard 4 suitably anchored with approved terminals	<input type="checkbox"/> Yes	<input type="checkbox"/> No
Are the cables in the terminals tensioned to their nominated torque	<input type="checkbox"/> Yes	<input type="checkbox"/> No
Has any minor damage been repaired using two coats of an organic zinc rich paint	<input type="checkbox"/> Yes	<input type="checkbox"/> No
Is the barrier system free from humps, sags or other irregularities	<input type="checkbox"/> Yes	<input type="checkbox"/> No
Has the ground or pavement around the post been left dense, tight and smooth	<input type="checkbox"/> Yes	<input type="checkbox"/> No
Are the barrier components free from splits, burrs or sharp edges after installation	<input type="checkbox"/> Yes	<input type="checkbox"/> No
Has the top of the post been cut or otherwise altered?	<input type="checkbox"/> Yes	<input type="checkbox"/> No

Disclaimer:

Important Note: The conformity of the installation is the responsibility of the installation contractor, and Ingal Civil Products accepts no liability for or in connection with any installation that is outside of the specifications of this manual or the Road Controlling Authority. For more information, please refer to our Standard Terms and Conditions of Sale available on our website: www.ingalcivil.com.au.

10.0 Repair

10.1 Damage Assessment

In the event of a vehicle impact, damage to the barrier is to be assessed in accordance with Table 6.

A Safe Work Method Statement is available from Ingal Civil Products upon request to assist in the safe repair of Ezy-Guard 4.

Any item that is replaced is to be reinstated observing the installation tolerances nominated in Section 7.14.

Only items purchased from Ingal Civil Products shall be used for the repair of Ezy-Guard 4.

10.2 Dismantling Sequence

Prior to undertaking dismantling due to a vehicle impact, the area should be assessed for hazards. These include trip hazards, sharp edges and snag points.

During a vehicle impact, the rail will disengage from the posts as they yield by bending at ground level.

The recommended dismantling sequence is as follows;

1. Dismantle the rail splice by removing the M16x32mm mushroom head bolts and nuts. There are 8 bolts located at each splice location.
2. Rails that are still attached to posts outside the impact area are disconnected by removing the M16x30mm post bolts. A 10mm hex key is required.

3. Once the area is clear of damaged rail, the posts can be removed. Since the posts yield by bending near ground level, a sling or chain can be attached below the bent section.
4. The damaged post can be lifted using a backhoe or post extractor attachment.
5. Any disturbed pavement material shall be left dense, tight, and smooth prior to the installation of replacement posts.

10.3 Bush Fire Damage

Ezy-Guard 4 does not contain any plastic, timber or rubber components that will burn.

The performance of galvanised coatings when subjected to fires depends upon a number of factors, such as flame duration, intensity and the characteristics of the galvanised coating.

Typical bushfire conditions may expose steel structures to an air temperature of 800°C for periods of up to 120 seconds, however zinc coatings are generally reflective and will not absorb heat at the same rate as an uncoated steel surface. Depending on the section thickness of the steel, the actual steel surface temperature may not exceed 350°C.

Typically, the bushfire flame duration and intensity are not high enough to compromise the structural strength of the steel. The hot dip galvanized coating will also typically remain unaffected through a bushfire event. If the bushfire causes damage to the galvanized surface, then the item(s) shall be replaced.

Table 6: Damage Assessment of Ezy-Guard 4

Type of Defect	Description of the Defect	Action to be Taken
Galvanizing damage on Z-Posts.	The sum total of the damaged area does not exceed 35cm ² (0.5% of the total surface area). The sum total of the damaged area exceeds 35cm ²	An organic zinc rich epoxy paint is to be applied to the repair area in two coats. The Z-post is to be replaced.
Galvanizing damage on rails.	The sum total of the damaged area does not exceed 200cm ² (0.5% of the total surface area) and no individual damaged area does not exceed 40cm ² . The sum total of the damaged area exceeds 200cm ² (0.5% of the total surface area) and/or an individual damaged area exceeds 40cm ² .	An organic zinc rich epoxy paint is to be applied to the repair area in two coats. The rail is to be replaced.
Mechanical damage on Ezy-Carriages.	The Ezy-Carriage has chips or cracks.	The Ezy-Carriage is to be replaced.
Mechanical damage on Z-Posts.	The post is bent. The Ezy-Carriage cannot travel freely along the post due to distortion.	The post is to be replaced. The post is to be replaced.
Mechanical damage on rail.	The rail is dented, twisted or flattened. There are tears in any part of the rail. The slots in the rail are distorted.	The rail is to be replaced. The rail is to be replaced. The rail is to be replaced.
Mechanical damage on bolts.	The body of the bolt is distorted. The thread of the bolt is damaged.	The bolt is to be replaced. The bolt is to be replaced.
Disturbance of material around posts	The material around the post is loose or uncompacted.	Any disturbed pavement or material around a post shall be left dense, tight and smooth so that resistance to water penetration is similar to that of the adjacent surface.

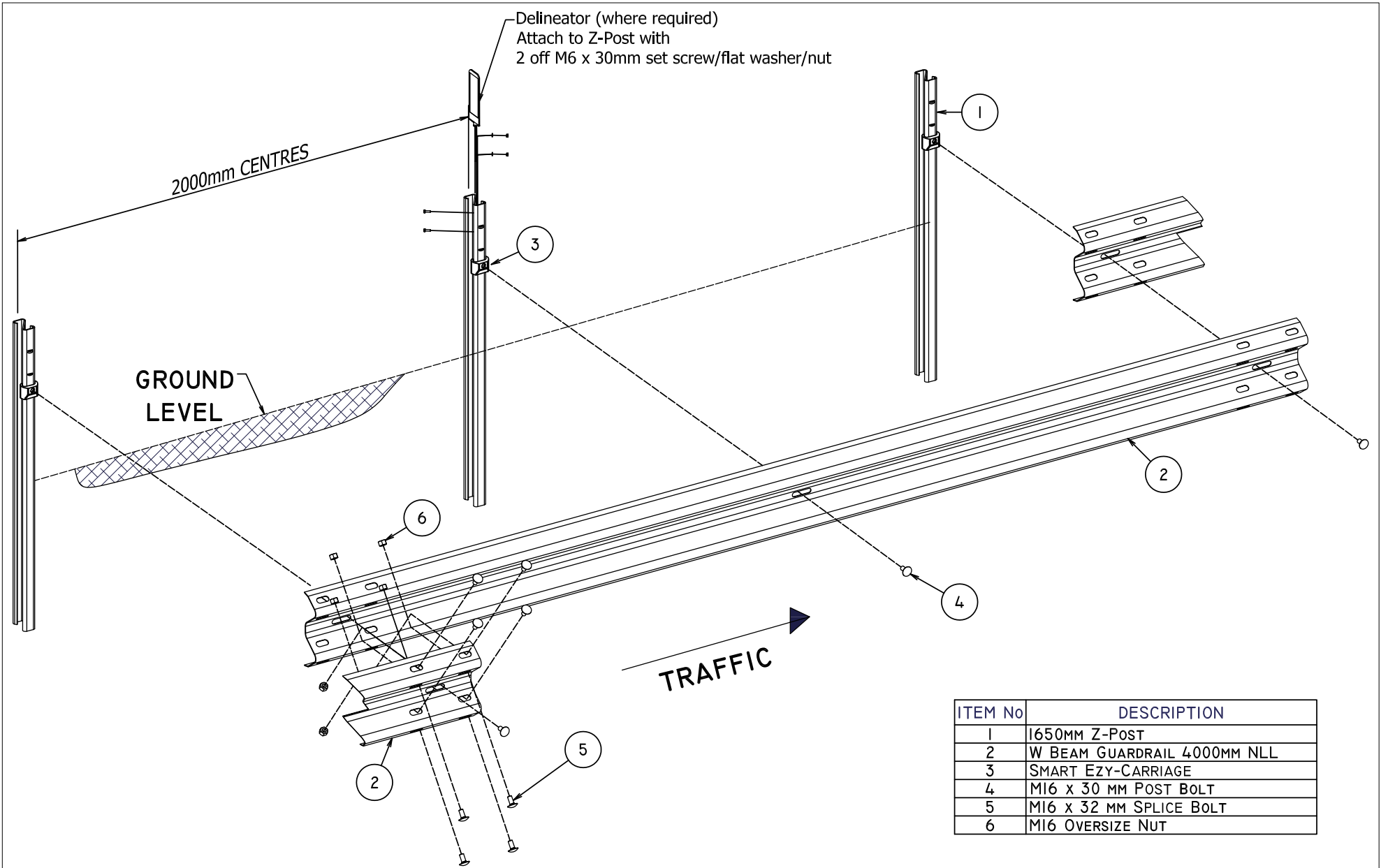

ITEM No	DESCRIPTION
1	1650MM Z-Post
2	W BEAM GUARDRAIL 4000MM NLL
3	SMART EZY-CARRIAGE
4	MI6 x 30 MM POST BOLT
5	MI6 x 32 MM SPLICE BOLT
6	MI6 OVERSIZE NUT

REV	DATE	DESCRIPTION	DRAWN	CHECKED	APPROVED	DRAWING NUMBER	REFERENCE DRAWINGS	NAME	DATE	INGAL CIVIL PRODUCTS	PROJECT	INGAL CIVIL PRODUCTS PART No.
								MC	02-03-2016	 DRAWING AND CONTENTS ARE COPYRIGHT TO INGAL CIVIL PRODUCTS AND CAN ONLY BE USED WITH PRIOR WRITTEN CONSENT FROM INGAL CIVIL PRODUCTS 57-65 AIRDS ROAD MINTO, N.S.W 2566 PH. +61 2 9827 3333 www.ingalcivil.com.au		
								LG	02-03-2016			
								LG	02-03-2016			
								N.T.S. @ A3				
								ISSUE FOR	INFORMATION ONLY			
											INGAL CIVIL PRODUCTS PART No.	
											DRAWING No.	EZY-SM-121
											TITLE	EZY-GUARD 4 2M POST SPACING EXPLODED ASSEMBLY DETAIL
											Rev	0

J:\SALES & MARKETING\DRAWINGS\EZY-GUARD ASSEMBLY\EZY-SM-121 - EZY-GUARD 4 ASSEMBLY - 2M SPACING.DWG

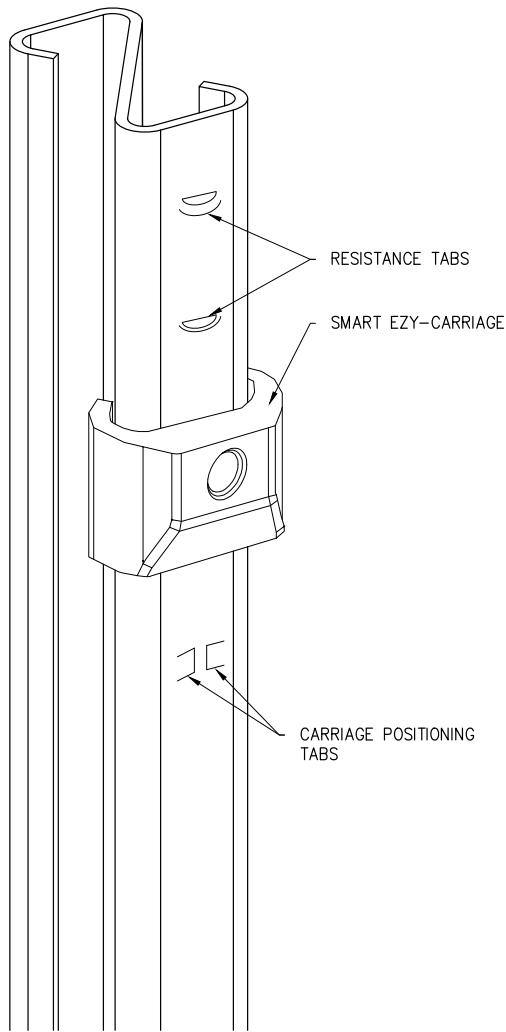

Z-POST & CARRIAGE ASSEMBLY
ISOMETRIC VIEW

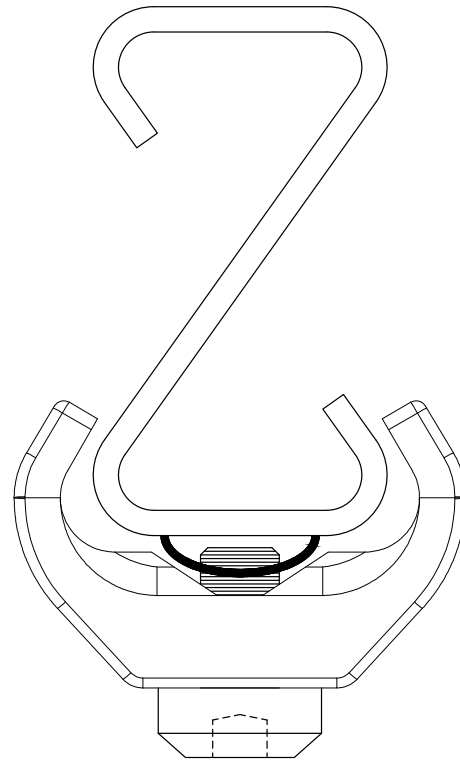

Z-POST & CARRIAGE ASSEMBLY
PLAN VIEW

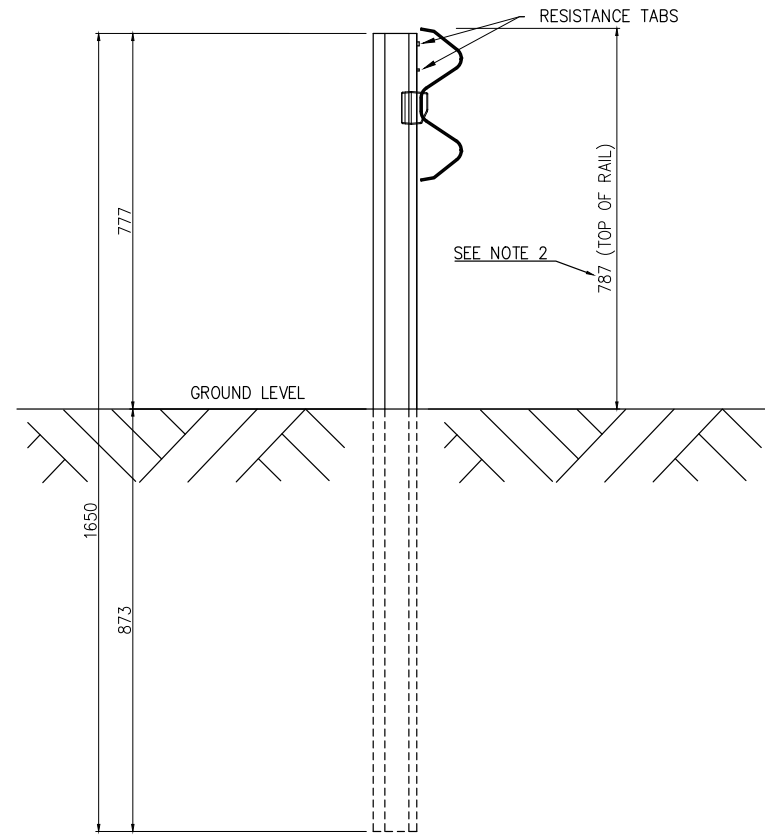

Z-POST & CARRIAGE ASSEMBLY
SIDE VIEW

NOTES:

1. TO BE READ IN CONJUNCTION WITH EZY-SM-116
2. HEIGHT TOLERANCE:
MASH TL3 +25mm/-50mm
NCHRP-350 TL4 +25mm/-0mm

REV	DATE	DESCRIPTION	DRAWN	CHECKED	APPROVED
7	13-03-2023	UPDATED NOTES TO REFLECT TOLERANCE	KZ	LG	LG
6	25-11-2019	REFERENCE DRAWING UPDATED	VB	LG	LG
5	02-07-2018	TOP OF RAIL HEIGHT TOLERANCE UPDATED	VB	LG	LG
4	02-03-2016	TOLERANCE ADDED	LG		
3	01-04-2015	NAME CHANGE (4)	LG	LG	LG
2	13-01-2015	DIM MOD	DJB	LG	LG
1	11-12-2014	DIM CORRECTION	DJB	LG	LG

DRAWING NUMBER	REFERENCE DRAWINGS

NAME	DATE
DRAWN DJB	01-12-2014
CHECKED LG	10-12-2014
APPROVED	
SCALE	N.T.S. @ A3
ISSUE FOR	INFORMATION ONLY

INGAL CIVIL PRODUCTS
A valmont COMPANY

DRAWING AND CONTENTS ARE COPYRIGHT TO
INGAL CIVIL PRODUCTS AND CAN ONLY BE USED
WITH PRIOR WRITTEN CONSENT FROM INGAL CIVIL
PRODUCTS

57-66 AIRDS ROAD PH. +61 2 9827 3333
MINTO, N.S.W 2566 www.ingalcivil.com.au

PROJECT	TITLE
INGAL CIVIL PRODUCTS PART No.	EZY-GUARD 4 ASSEMBLY DETAIL

DRAWING No.	Rev.
EZY-SM-034	7

F:\ENGINEERING\SALES & MARKET DRAWINGS\EZY-GUARD ASSEMBLY\EZY-SM-034 - EZY-GUARD 4 - 787MM.DWG

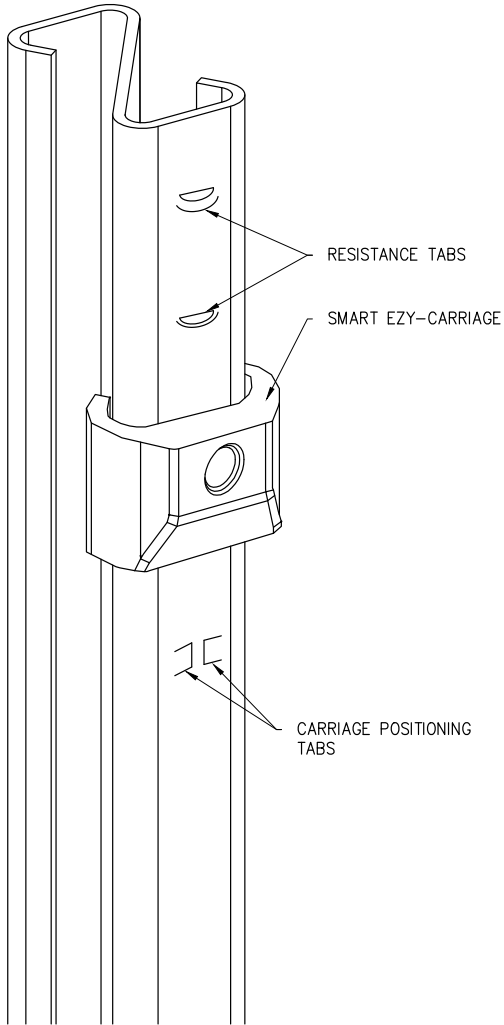

Z-POST & CARRIAGE ASSEMBLY
ISOMETRIC VIEW

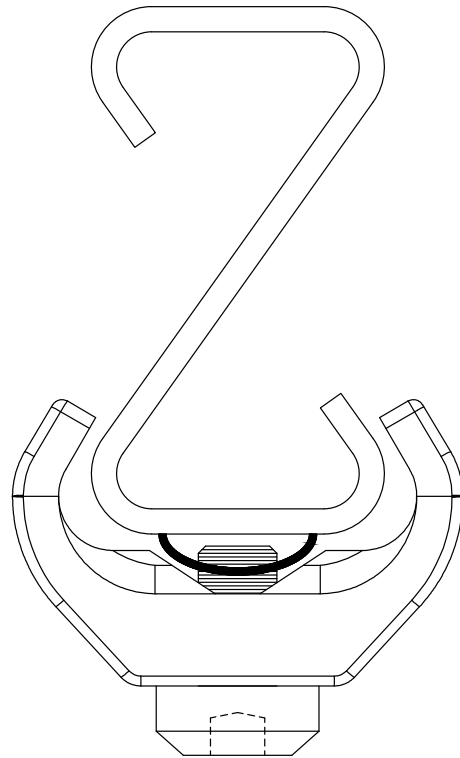

Z-POST & CARRIAGE ASSEMBLY
PLAN VIEW

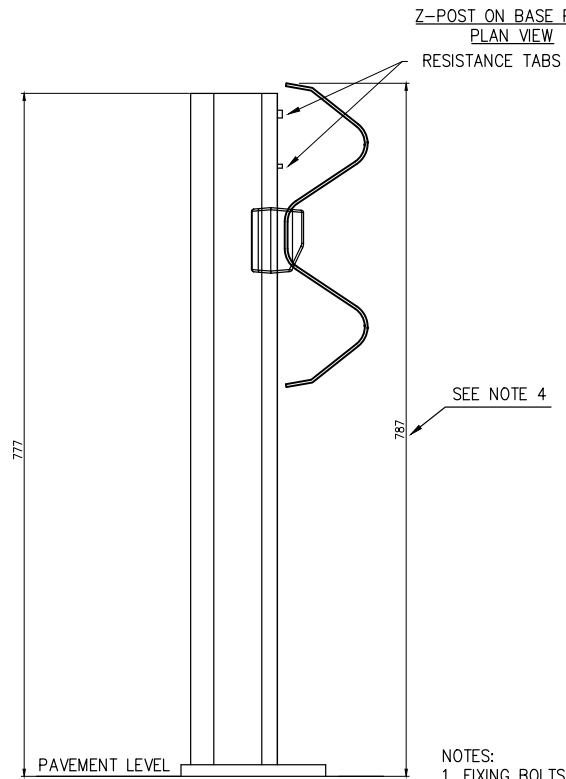

Z-POST & CARRIAGE ASSEMBLY
SIDE VIEW

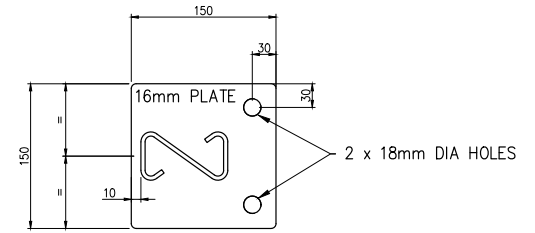

Z-POST ON BASE PLATE
PLAN VIEW

RESISTANCE TABS

NOTE: ACCEPTANCE OF PRODUCT VARIANTS TO BE CONFIRMED BEFORE INSTALLATION.

- NOTES:
1. FIXING BOLTS TO BE M16 G8.8 THREADED RODS FIXED WITH HILTI RE-500 EPOXY
 2. MINIMUM FIXING BOLT EMBEDMENT DEPTH – 210mm
 3. MINIMUM CONCRETE SUBSTRATE THICKNESS – 270mm
 4. HEIGHT TOLERANCE:
MASH TL3 +25mm/-50mm
NCHRP-350 TL4 +25mm/-0mm

REVISIONS						REFERENCES			DRAWING		PROJECT		DRAWING No.	
REV	DATE	DESCRIPTION	DRAWN	CHECKED	APPROVED	DRAWING NUMBER	REFERENCE DRAWINGS	NAME	DATE	TITLE	INGAL CIVIL PRODUCTS PART No.	DRAWING No.	Rev:	
1	13-03-2023	UPDATED NOTES TO REFLECT TOLERANCE	KZ	LG	LG			MC	02-03-2016	<p>DRAWING AND CONTENTS ARE COPYRIGHT TO INGAL CIVIL PRODUCTS AND CAN ONLY BE USED WITH PRIOR WRITTEN CONSENT FROM INGAL CIVIL PRODUCTS 37-65 AIRDS ROAD MINTO, N.S.W 2566 PH. +61 2 9827 3333 www.ingalcivil.com.au</p>	EZY-GUARD 4 Z-POST ON BASE PLATE - 2M POST SPACING ASSEMBLY DETAIL	EZY-SM-123	1	
0		ORIGINAL ISSUE					LG	02-03-2016						
							LG	02-03-2016						
							N.T.S.	A3						
								INFORMATION ONLY						

F:\ENGINEERING\SALES & MARKETING\DRAWINGS\EZY-GUARD ASSEMBLY\EZY-SM-123 - EZY-GUARD 4 - POB DETAIL.DWG

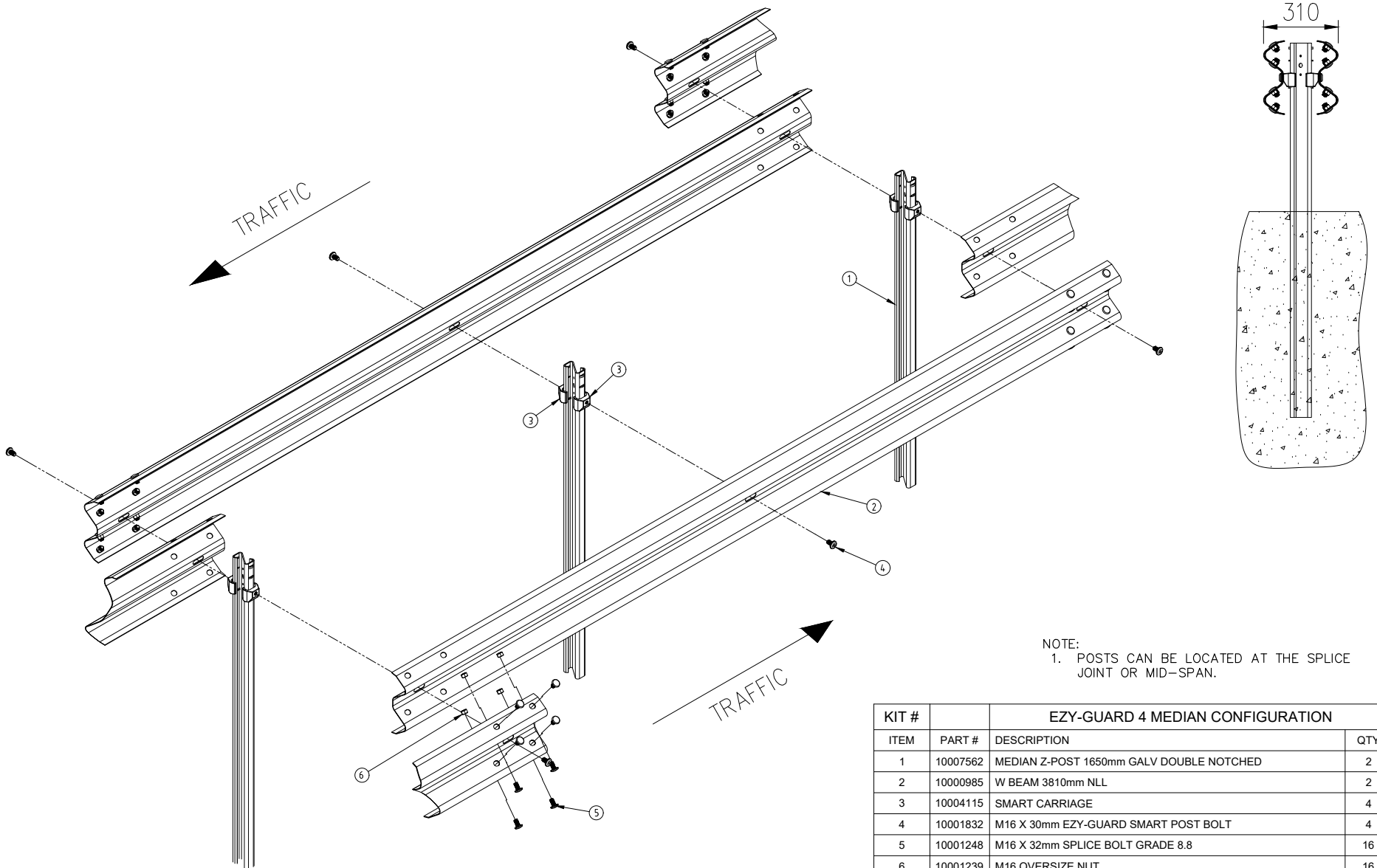

NOTE:
1. POSTS CAN BE LOCATED AT THE SPLICE JOINT OR MID-SPAN.

KIT #	EZY-GUARD 4 MEDIAN CONFIGURATION		
ITEM	PART #	DESCRIPTION	QTY
1	10007562	MEDIAN Z-POST 1650mm GALV DOUBLE NOTCHED	2
2	10000985	W BEAM 3810mm NLL	2
3	10004115	SMART CARRIAGE	4
4	10001832	M16 X 30mm EZY-GUARD SMART POST BOLT	4
5	10001248	M16 X 32mm SPLICE BOLT GRADE 8.8	16
6	10001239	M16 OVERSIZE NUT	16

REV	DATE	DESCRIPTION	DRAWN	CHECKED	APPROVED
6	10-08-2021	NOTE 1 ADDED	VB	LG	LG
5	26-11-2019	PART LIST AND TITLE BLOCK UPDATED	VB	BS	LG
4	02-03-2016	FOOTPRINT DIM ADDED	LG	SE	LG
3	03-12-2015	AU REFERENCE REMOVED	LG	SE	LG
2	10-06-16	TITLE CHANGE	LG	SE	LG
1	01-06-16	TITLE CHANGE	LG	SE	LG

REV	DATE	DESCRIPTION	DRAWN	CHECKED	APPROVED
6	10-08-2021	NOTE 1 ADDED	VB	LG	LG
5	26-11-2019	PART LIST AND TITLE BLOCK UPDATED	VB	BS	LG
4	02-03-2016	FOOTPRINT DIM ADDED	LG	SE	LG
3	03-12-2015	AU REFERENCE REMOVED	LG	SE	LG
2	10-06-16	TITLE CHANGE	LG	SE	LG
1	01-06-16	TITLE CHANGE	LG	SE	LG

DRAWN: AUSCOL 03-02-2015
 CHECKED: LG 04-02-2015
 APPROVED: LG 04-02-2015
 SCALE: N.T.S. @ A3
 ISSUE FOR: INFORMATION ONLY

PROJECT	INGAL CIVIL PRODUCTS PART No. N/A
TITLE	EZY-GUARD 4 MEDIAN CONFIGURATION
DRAWING No.	EZY-SM-035

Rev	6
-----	---

F:\ENGINEERING\SALES & MARKETING\DRAWINGS\EZY-GUARD ASSEMBLY\EZY-SM-035 - EZY-GUARD 4 MEDIAN CONFIGURATION - 78MM.DWG

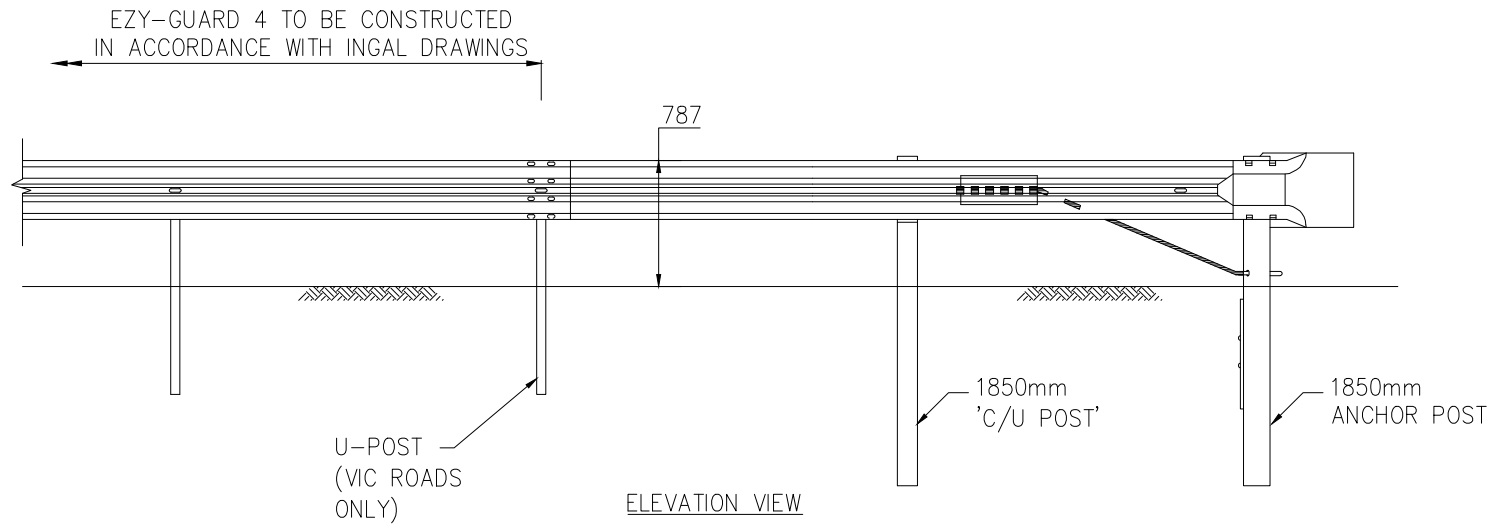
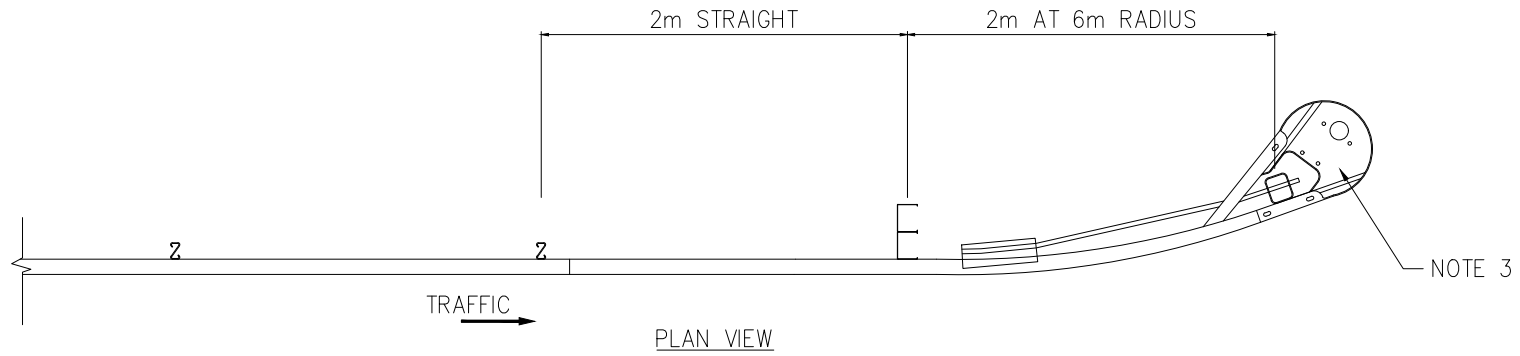

- NOTE**
1. TRAILING TERMINAL TO BE USED IN DEPARTURE END OF SAFETY BARRIER ONLY.
 2. NOT TO BE USED WITHIN CLEAR ZONE OF OPPOSING TRAFFIC.
 3. BULLNOSE DIAPHRAGM NOT REQUIRED IN VICTORIA.

REV	DATE	DESCRIPTION	DRAWN	CHECKED	APPROVED	DRAWING NUMBER	REFERENCE DRAWINGS	NAME	DATE	INGAL CIVIL PRODUCTS 57-65 AIRDS ROAD MINTO, N.S.W AUSTRALIA 2566 PH. +61 2 9827 3333 FAX +61 2 9827 3300 www.ingalcivil.com.au	PROJECT EZY-GUARD 4	INGAL CIVIL PRODUCTS REFERENCE No.
3	30.11.2018	ADDED NOTE TO 3RD POST	VB	LG	LG			DRAWN	AR	13-04-2015		
2	02.11.2018	ADDED NOTE 3	VB	LG	LG			CHECKED	LG	13-04-2015		
1	17.10.2018	UPDATED 3RD POST	VB	LG	LG			APPROVED	LG	13-04-2015		
0								SCALE	NTS		TITLE CONNECTION TO TRAILING TERMINAL	DRAWING No. EZY-SM-106
								SIZE	A4			REV. 3

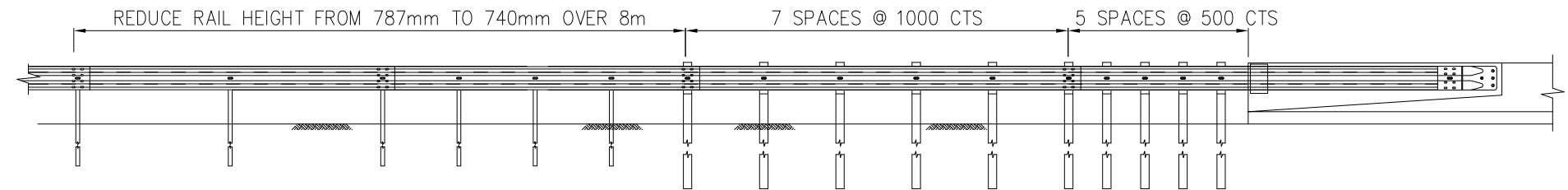

VICROADS TYPE-B 10m BRIDGE APPROACH

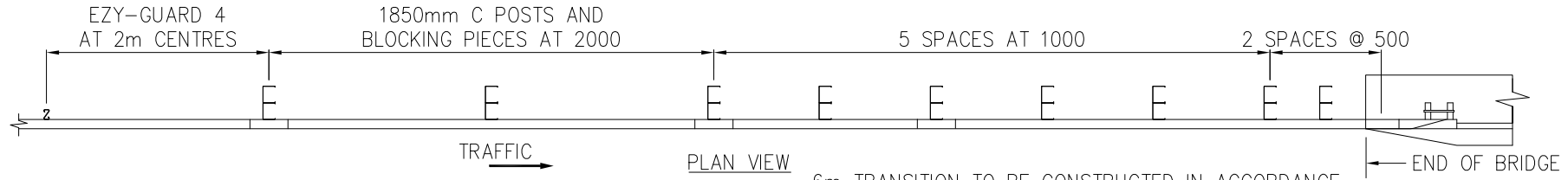

PLAN VIEW

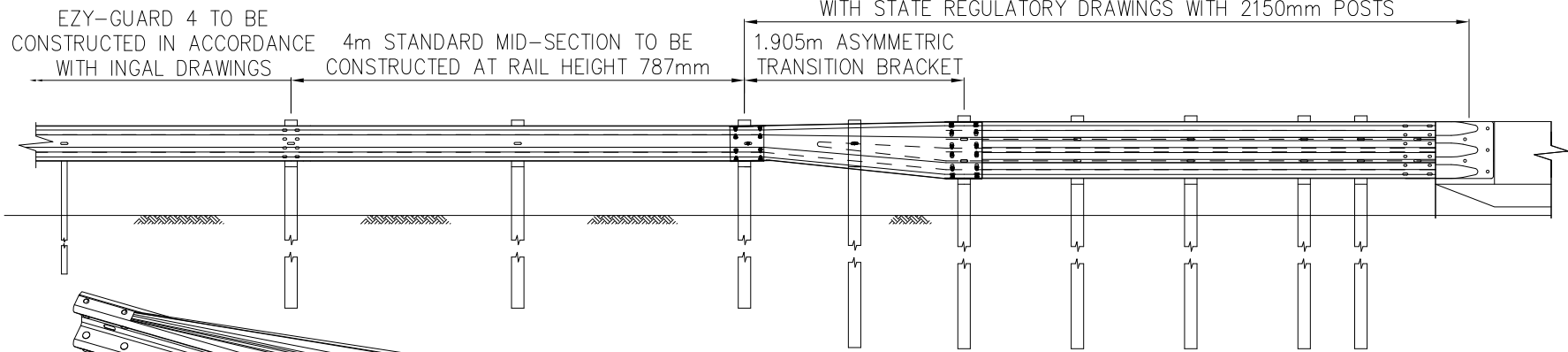

ELEVATION VIEW

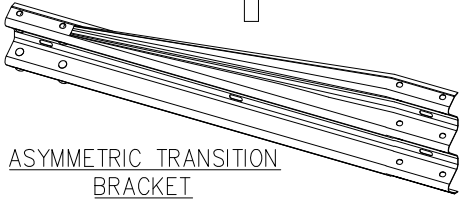

ASYMMETRIC TRANSITION BRACKET

- NOTES:
- 1 RMS-NSW BRIDGE APPROACH SHOWN FOR ILLUSTRATION.
 - 2 FOR QLD-TMR SPEC BRIDGE APPROACH, SYMMETRICAL TRANSITION BRACKET TO BE USED.

REVISIONS			REFERENCES			NAME		DATE		INGAL CIVIL PRODUCTS 57-65 AIRDS ROAD MINTO, N.S.W. AUSTRALIA 2566 PH. +61 2 9827 3333 FAX +61 2 9827 3300 www.ingalcivil.com.au	PROJECT	INGAL CIVIL PRODUCTS PART No.	
REV	DATE	DESCRIPTION	DRAWN	CHECKED	APPROVED	DRAWING NUMBER	REFERENCE DRAWINGS	SCALE			ISSUE FOR	TITLE	DRAWING No.
1	17-07-2017	VICROADS TRANSITION ADDED	AUSCOL	LG	LG			N.T.S. @ A3			INFORMATION ONLY	EZY-GUARD 4	N/A
												TRANSITION TO RIGID CONCRETE BARRIER	EZY-SM-108

Rev. 1

ISSUES & MARKETING DRAWINGS EZY-GUARD ASSEMBLY EZY-SM-108 EZY-GUARD 4 THREEBEAM CONNECTION TO BRIDGE/DWG

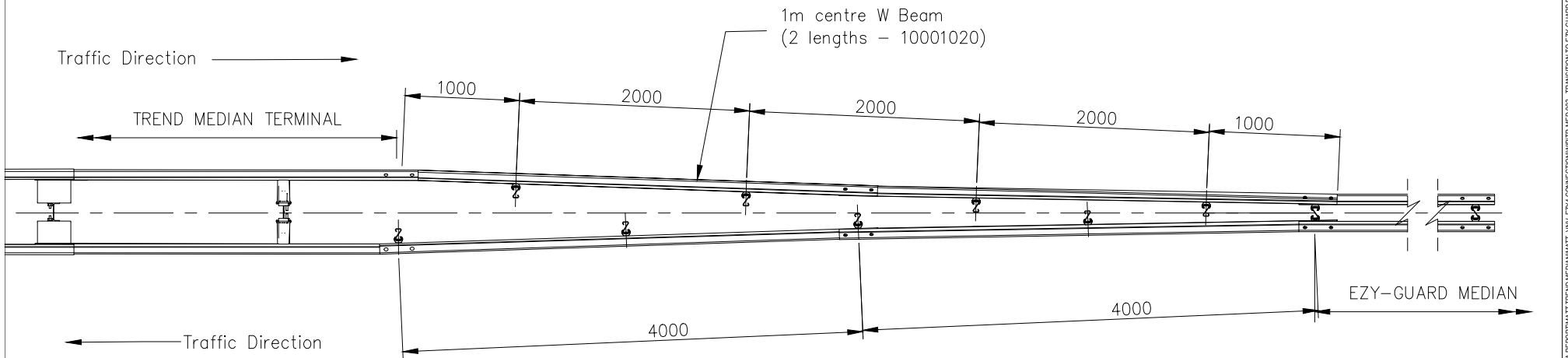
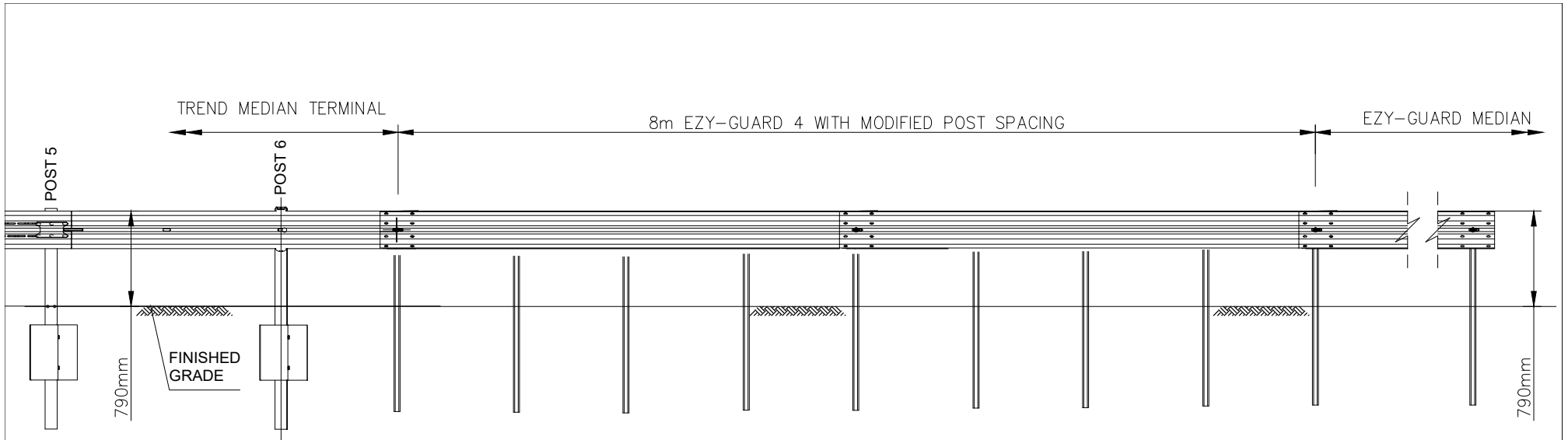

TO BE READ IN CONJUNCTION WITH THE TREND MEDIAN AND EZY-GUARD 4 PRODUCT MANUALS.

REV	DATE	DESCRIPTION	DRAWN	CHECKED	APPROVED	DRAWING NUMBER	REFERENCE DRAWINGS	SCALE	ISSUE FOR	NAME	DATE	PROJECT	TITLE	INGAL CIVIL PRODUCTS PART No.	DRAWING No.
1	25-10-2022	UPDATED THE POST POSITION	KZ	LG	LG			N.T.S. @ A3	INFORMATION ONLY	LG	17-02-2022	INGAL CIVIL PRODUCTS	TREND MEDIAN TRANSITION TO EZY-GUARD 4		TR-MED-002
										DRAWING AND CONTENTS ARE COPYRIGHT TO INGAL CIVIL PRODUCTS AND CAN ONLY BE USED WITH PRIOR WRITTEN CONSENT FROM INGAL CIVIL PRODUCTS 57-65 AIRDS ROAD MINTO, N.S.W. 2566 PH. +61 2 9827 3333 www.ingalcivil.com.au					

F:\ENGINEERING4 DRAWINGS IN PROGRESS\WP - KZLS.DWG\REPORT\MATT TREND MEDIAN\MATT_VINU_EZY4.CONNECTION\WP\TR-MED002 - TRANSITION TO EZY-GUARD.DWG

Item No.	Description - Ezy-Lift Retrofit Kit	Part No.	Qty
3	EZY-ABE Overlay Carriage HDG	10008353	1
4	M16 x 30mm Ezy-Guard Smart Post Bolt	10001832	1
7	M16 Round Washer	10001242	1
8	M16 Rectangular Washer 3mm	10001243	1

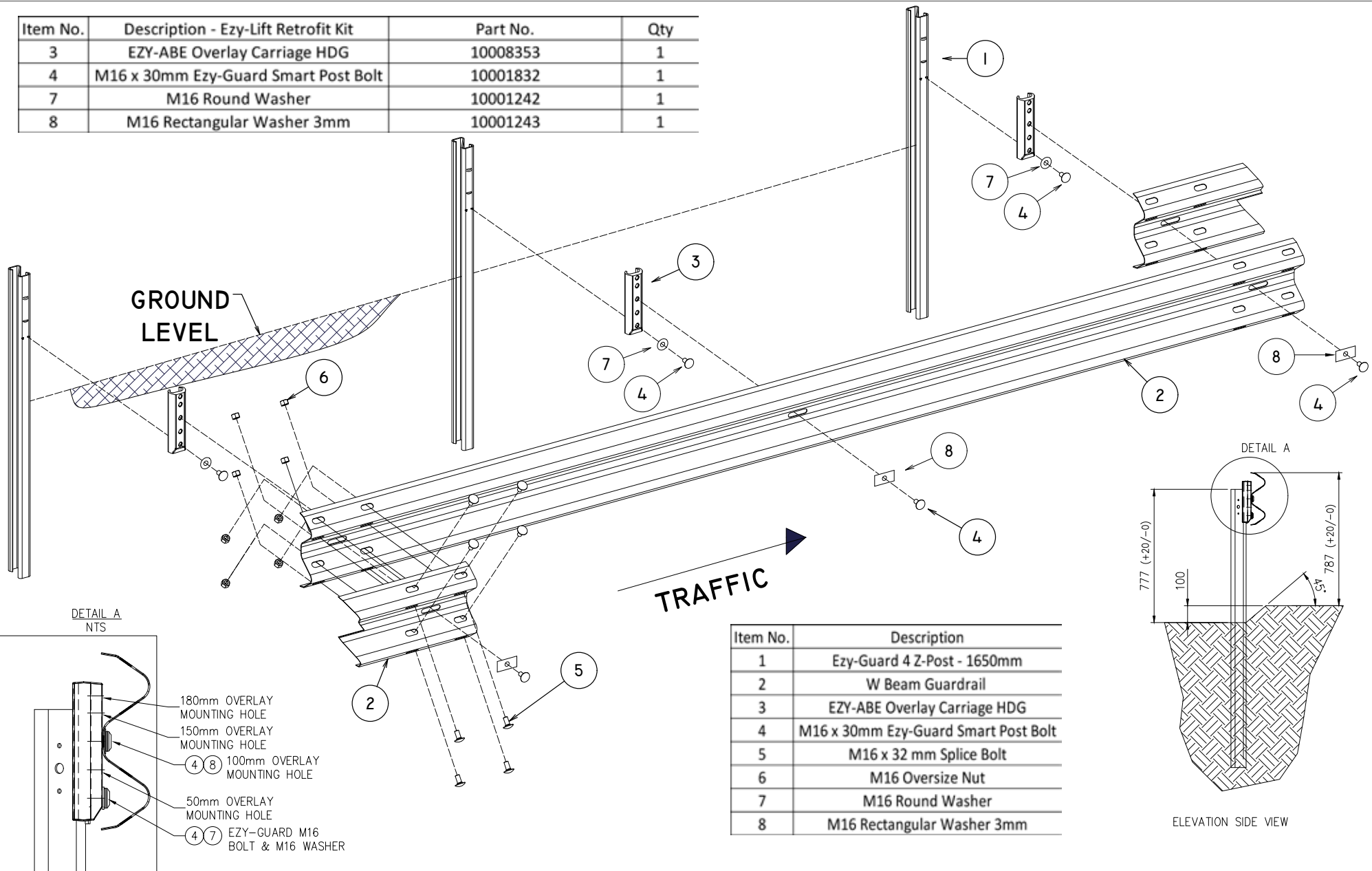

Item No.	Description
1	Ezy-Guard 4 Z-Post - 1650mm
2	W Beam Guardrail
3	EZY-ABE Overlay Carriage HDG
4	M16 x 30mm Ezy-Guard Smart Post Bolt
5	M16 x 32 mm Splice Bolt
6	M16 Oversize Nut
7	M16 Round Washer
8	M16 Rectangular Washer 3mm

REV	DATE	DESCRIPTION	DRAWN	CHECKED	APPROVED
3	29-03-18	DETAIL A TABLE ADDED	WD	LG	
2	29-03-17	DRAWING TITLE UPDATED	MC	LG	
1	15-02-2017	PART NUMBERING CORRECTION - LOWER CARRIAGE BOLT	LG		

REV	DATE	DESCRIPTION	DRAWN	CHECKED	APPROVED

NAME	DATE
DRAWN MC	13-12-16
CHECKED LG	13-12-16
APPROVED LG	13-12-16
SCALE N.T.S. @ A3	
ISSUE FOR INFORMATION ONLY	

DRAWING AND CONTENTS ARE COPYRIGHT TO
INGAL CIVIL PRODUCTS AND CAN ONLY BE USED
WITH PRIOR WRITTEN CONSENT FROM INGAL CIVIL
PRODUCTS
57-65 AIRDS ROAD PH. +61 2 9827 3333
MINTO, N.S.W 2566 www.ingalcivil.com.au

PROJECT	INGAL CIVIL PRODUCTS PART No.
TITLE	DRAWING No.
EZY-GUARD 4 WITH EZY-LIFT CARRIAGE EXPLODED ASSEMBLY DETAIL	EZY-SM-131

Rev: 3

F:\ENGINEERING\SALES & MARKETING\DRAWINGS\EZY-GUARD ASSEMBLY\EZY-SM-131 - EZY-LIFT EXPLODED ASSEMBLY.DWG

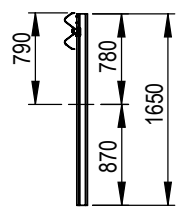
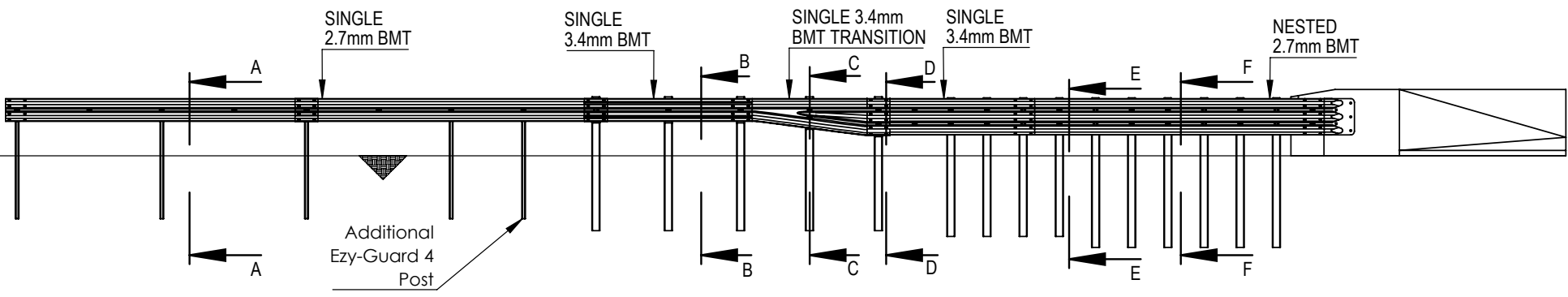
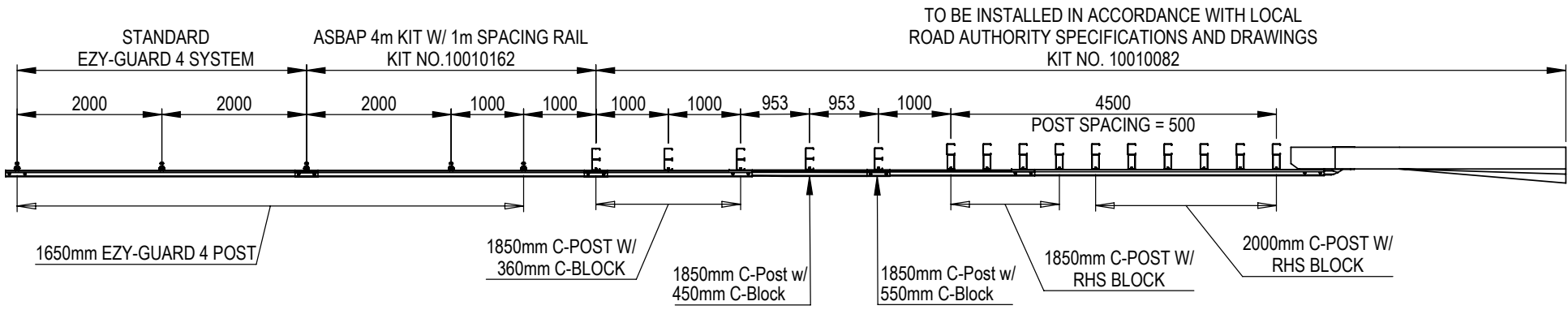

SECTION A-A
Ezy-Guard 4 Post

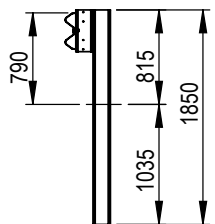

SECTION B-B
1850mm C-Post w/
360mm C-Block

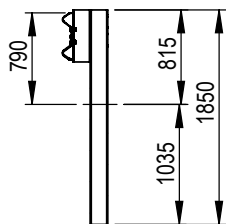

SECTION C-C
1850mm C-Post w/
450mm C-Block

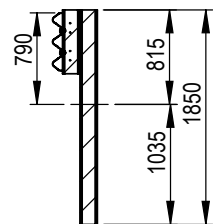

SECTION D-D
1850mm C-Post w/
550mm C-Block

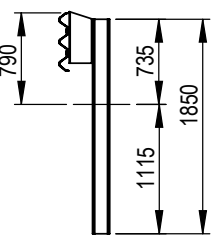

SECTION E-E
1850mm C-Post w/
RHS Block

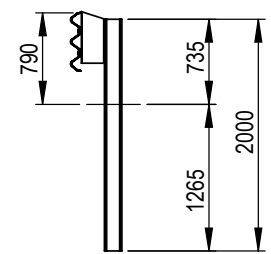

SECTION F-F
2000mm C-Post w/
RHS Block

- NOTES:**
- TO BE READ IN CONJUNCTION WITH RELEVANT STATE ROAD AUTHORITY DRAWINGS AND SPECIFICATIONS
 - LHS **APPROACH** CONFIGURATION

REVISIONS

REV.	DATE	DESCRIPTION	drawn	checked	APPROVED

REFERENCES

DRAWING NUMBER	REFERENCE DRAWINGS

NAME	DATE
DRAWN KZ	11-04-2022
CHECKED LG	11-04-2022
APPROVED LG	24-05-2022
SCALE	1:78
ISSUE FOR	

INGAL CIVIL PRODUCTS
DRAWING AND CONTENTS ARE COPYRIGHT TO INGAL CIVIL PRODUCTS AND CAN ONLY BE USED WITH PRIOR WRITTEN CONSENT FROM INGAL CIVIL PRODUCTS
57-66 AIRDS ROAD
MURDOCH, W.A. 6150
PH: +61 2 9827 3333
www.ingalcivil.com.au

PROJECT	ASBAP TRANSITION
TITLE	ASBAP TRANSITION TO EZY-GUARD 4 - LHS APPROACH

INGAL CIVIL PRODUCTS PART NO.	10010082
DRAWING No.	EZY-SM-148
Rev.	0

FOLDER: E:\ENGINEERING\CURRENT DRAWINGS\COMPONENT DRAWINGS\SLIDING\ASBAP_TRANSITIONS

TO BE INSTALLED IN ACCORDANCE WITH LOCAL ROAD
AUTHORITY SPECIFICATIONS AND DRAWINGS
KIT NO. 10010152

ASBAP 4m KIT W/ 1m SPACING RAIL
KIT NO.10010162

STANDARD
EZY-GUARD 4 SYSTEM

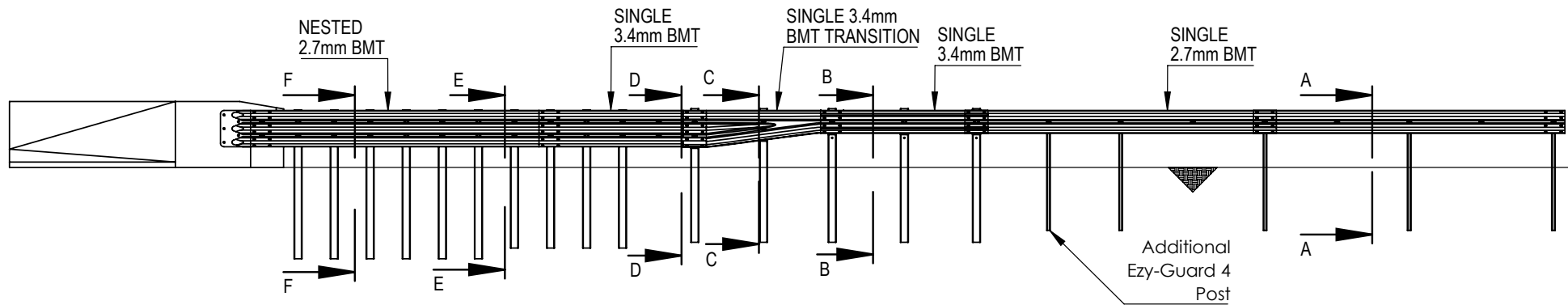
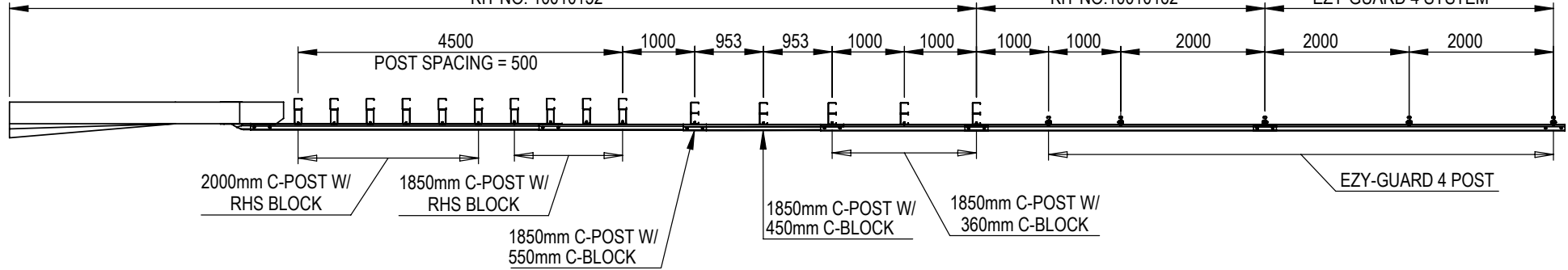

NOTES:
• TO BE READ IN CONJUNCTION WITH RELEVANT STATE ROAD AUTHORITY DRAWINGS AND SPECIFICATIONS LHS DEPARTURE CONFIGURATION

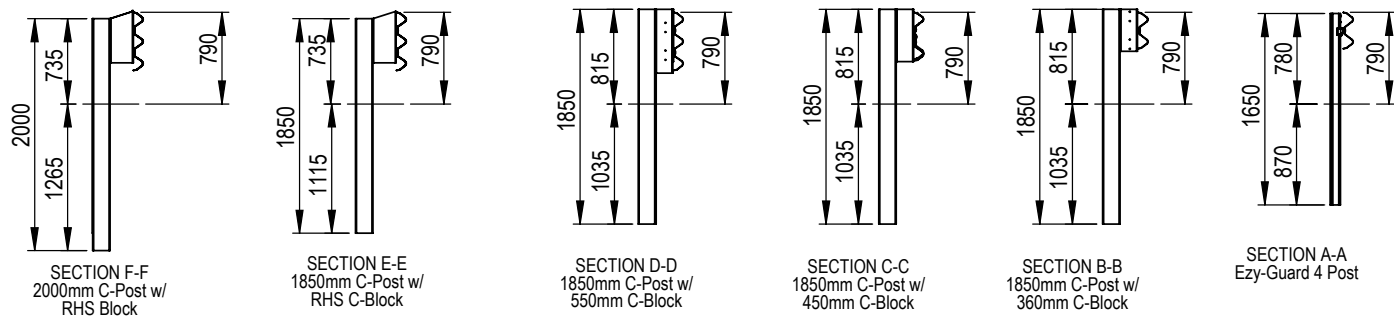

REVISIONS	REV	DATE	DESCRIPTION	DRAWN	CHECKED	APPROVED	<p>DRAWING AND CONTENTS ARE COPYRIGHT TO INGAL CIVIL PRODUCTS AND CAN ONLY BE USED WITH PRIOR WRITTEN CONSENT FROM INGAL CIVIL PRODUCTS</p> <p>37-65 PARKS ROAD MIRVO, N.S.W 2566</p> <p>PH: +61 2 9827 3333 www.ingalcivil.com.au</p>	PROJECT ASBAP TRANSITION TITLE ASBAP TRANSITION TO EZY-GUARD 4 - LHS DEPARTURE	INGAL CIVIL PRODUCTS PART NO. 10010152 DRAWING NO. EZY-SM-155
	REFERENCES			DRAWN	KZ	11-04-2022			
	DRAWING NUMBER			CHECKED	LG	11-04-2022			
	REFERENCE DRAWINGS			APPROVED	LG	24-05-2022			
				SCALE	1:78				
			ISSUE FOR						
Rev: 0									

FOLDER: F:\ENGINEERING\3. CURRENT DRAWINGS\COMPONENT DRAWINGS\DDRW\3. SOLID MODEL\ASBAP TRANSITIONS\CURRENT MODEL

TO BE INSTALLED IN ACCORDANCE WITH LOCAL ROAD
AUTHORITY SPECIFICATIONS AND DRAWINGS
KIT NO. 100XXXXX

STANDARD
EZY-GUARD 4 SYSTEM

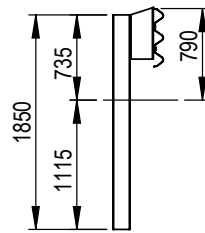
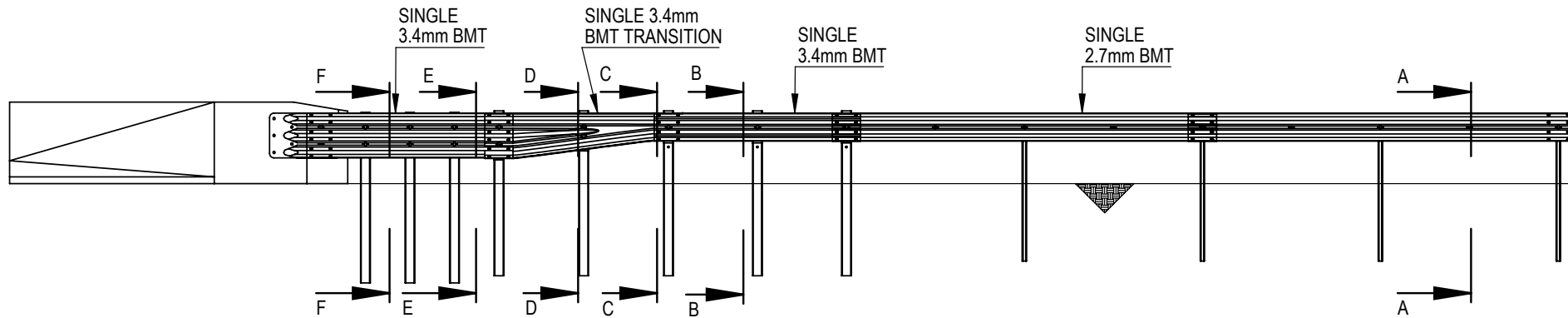
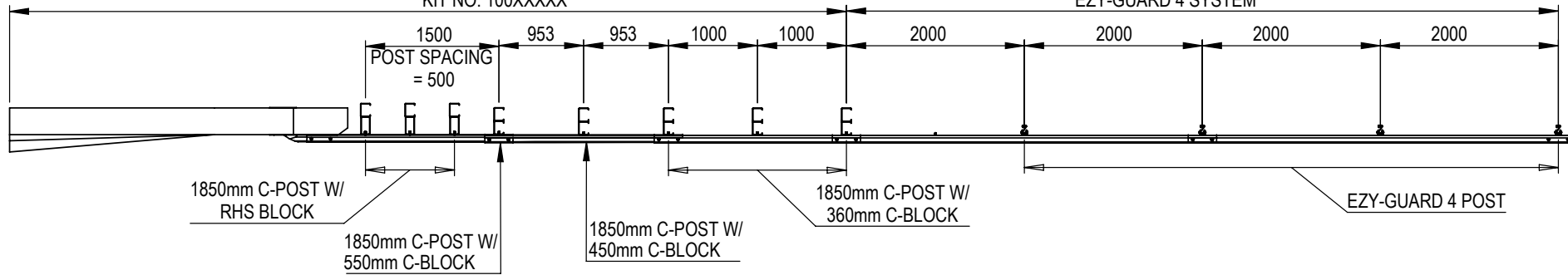

SECTION F-F
1850mm C-Post w/
RHS Block

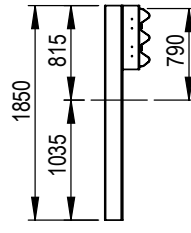

SECTION E-E
1850mm C-Post w/
550mm C-Block

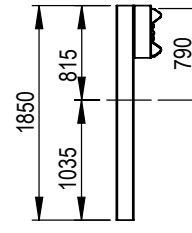

SECTION D-D
1850mm C-Post w/
450mm C-Block

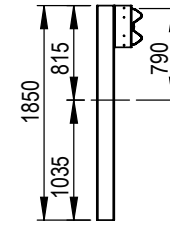

SECTION C-C
1850mm C-Post w/
360mm C-Block

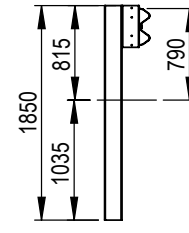

SECTION B-B
1850mm C-Post w/
360mm C-Block

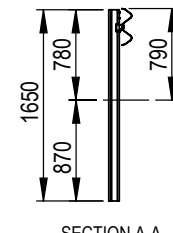

SECTION A-A
Ezy-Guard 4 Post

- NOTES:
- TO BE READ IN CONJUNCTION WITH RELEVANT STATE ROAD AUTHORITY DRAWINGS AND SPECIFICATIONS
 - LHS DEPARTURE CONFIGURATION SHORT VER.

REV.	DATE	DESCRIPTION	DRAWN	CHECKED	APPROVED

DRAWING NUMBER	REFERENCE DRAWINGS

NAME	DATE
DRAWN KZ	11/04/2022
CHECKED LG	20/06/2022
APPROVED LG	20/06/2022
SCALE	1:65
ISSUE FOR	

	PROJECT ASBAP TRANSITION	INGAL CIVIL PRODUCTS PART NO. 1001XXXX
	TITLE ASBAP TRANSITION TO EZY-GUARD 4 - LHS DEPARTURE - SHORT VER.	DRAWING NO. EZY-SM-156

Rev. 0

FOLDER: F:\ENGINEERING\3. CURRENT DRAWINGS\COMPONENT DRAWINGS\SDR\WLS_SOLID MODEL\ASBAP TRANSITION\CURRENT MODEL

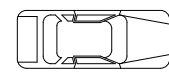
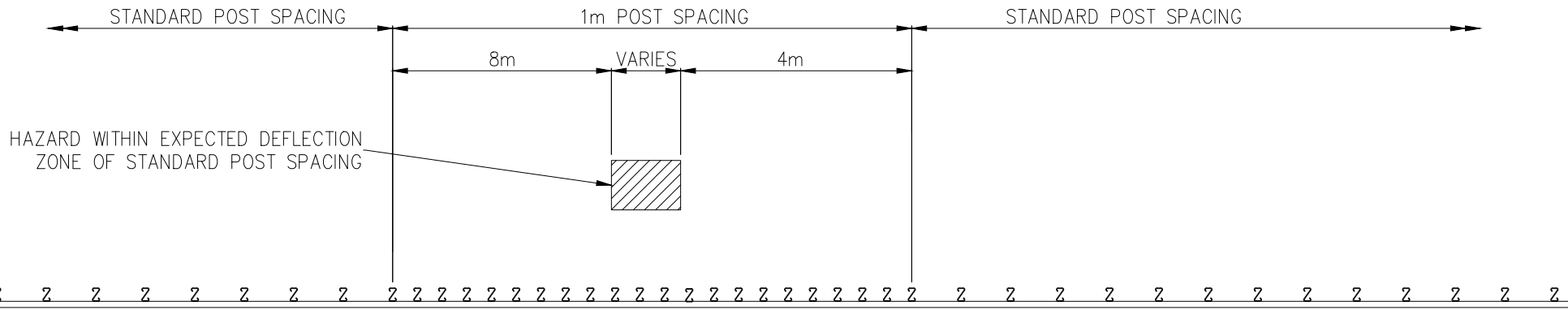

→ DIRECTION OF TRAVEL

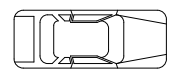

NOTES:

1. TO BE READ IN CONJUNCTION WITH THE EZY-GUARD PRODUCT MANUAL.
2. THE EZY-GUARD 4 SYSTEM HAS BEEN FULLY CRASH TESTED IN ACCORDANCE WITH MASH TEST LEVEL 3 AND NCHRP-350 TL4 WITH POSTS INSTALLED AT 2m CENTERS.
TO DETERMINE THE SYSTEMS PERFORMANCE WITH ALTERNATIVE CONFIGURATIONS, SUCH AS REDUCED POST SPACINGS, A NON-LINEAR FINITE ELEMENT MODEL OF THE SYSTEM HAS BEEN USED. THE MODEL WAS BUILT IN COMPLIANCE WITH NCHRP-179 - PROCEDURES FOR VERIFICATION AND VALIDATION OF COMPUTER SIMULATIONS USED FOR ROADSIDE SAFETY APPLICATIONS.
3. TOTAL LENGTH OF REDUCED POST SPACING WILL DEPEND ON LENGTH OF HAZARD.
4. MINIMUM OF 8m OF 1m SPACING BARRIER SHALL BE INSTALLED UPSTREAM AND 4m DOWNSTREAM OF SINGLE POINT HAZARD ON ONE WAY ROAD.
5. THE USE OF 1m POST SPACING SHOULD BE LIMITED TO CONSTRAINED LOCATIONS.

6. 4m KIT WITH W-BEAM PANEL SLOTS AT 1m CENTERS IS AVAILABLE.
EZY-G SMART KIT# 10008441.
EZY-G 4 KIT# 10008616.

REV	DATE	DESCRIPTION	DRAWN	CHECKED	APPROVED	DRAWING NUMBER	REFERENCE DRAWINGS	NAME	DATE	SCALE	SIZE
3	19-09-2024	NOTES UPDATED	KZ	HF	KZ			DRAWN	DJB	05/10/2011	
2	20-09-2021	NOTES UPDATED	VB	LG	LG			CHECKED	TC	05/10/2011	
1	23/5/2021	DEPARTURE ANGLES REMOVED. DIMENSIONS & NOTES ADDED.	VB	LG	LG			APPROVED	TC	05/10/2011	
0	05/10/11	ISSUED FOR REVIEW	DJB	TC	TC						

<p>INGAL CIVIL PRODUCTS 57-65 AIRDS ROAD MINTO, N.S.W AUSTRALIA 2566 PH. +61 2 9827 3333 FAX +61 2 9827 3300 www.ingalcivil.com.au</p>	PROJECT EZY-GUARD SMART/4	INGAL CIVIL PRODUCTS REFERENCE No.
	DRAWING AND CONTENTS ARE COPYRIGHT TO INGAL CIVIL PRODUCTS AND CAN ONLY BE USED WITH PRIOR WRITTEN CONSENT FROM INGAL CIVIL PRODUCTS	TITLE HALF POST SPACING ONE WAY ROAD

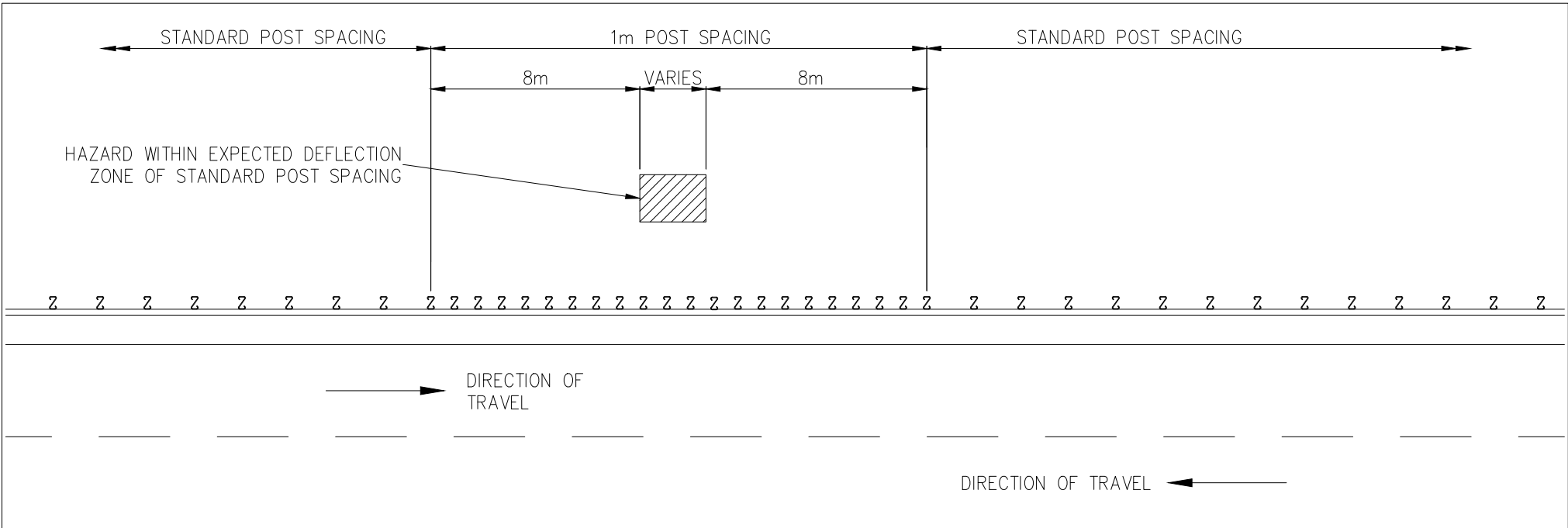

NOTES:

1. TO BE READ IN CONJUNCTION WITH THE EZY-GUARD PRODUCT MANUAL.
2. THE EZY-GUARD 4 SYSTEM HAS BEEN FULLY CRASH TESTED IN ACCORDANCE WITH MASH TEST LEVEL 3 AND NCHRP-350 TL4 WITH POSTS INSTALLED AT 2m CENTERS.
TO DETERMINE THE SYSTEMS PERFORMANCE WITH ALTERNATIVE CONFIGURATIONS, SUCH AS REDUCED POST SPACINGS, A NON-LINEAR FINITE ELEMENT MODEL OF THE SYSTEM HAS BEEN USED. THE MODEL WAS BUILT IN COMPLIANCE WITH NCHRP-179 - PROCEDURES FOR VERIFICATION AND VALIDATION OF COMPUTER SIMULATIONS USED FOR ROADSIDE SAFETY APPLICATIONS.
3. TOTAL LENGTH OF REDUCED POST SPACING WILL DEPEND ON LENGTH OF HAZARD.
4. MINIMUM OF 8m OF 1m SPACING BARRIER SHALL BE INSTALLED UPSTREAM AND DOWNSTREAM OF SINGLE POINT HAZARD ON TWO WAY ROAD.
5. THE USE OF 1m POST SPACING SHOULD BE LIMITED TO CONSTRAINED LOCATIONS.

6. 4m KIT WITH W-BEAM PANEL SLOTS AT 1m CENTERS IS AVAILABLE.
EZY-G SMART KIT# 10008441.
EZY-G 4 KIT# 10008616.

REV	DATE	DESCRIPTION	DRAWN	CHECKED	APPROVED	DRAWING NUMBER	REFERENCE DRAWINGS	NAME	DATE	INGAL CIVIL PRODUCTS 57-65 AIRDS ROAD MINTO, N.S.W AUSTRALIA 2566 PH. +61 2 9827 3333 FAX +61 2 9827 3300 www.ingalcivil.com.au	PROJECT EZY-GUARD SMART/4	INGAL CIVIL PRODUCTS REFERENCE No.
3	19-09-2024	NOTES UPDATED	KZ	HF	KZ			DRAWN	DJB	05/10/2011		
2	23-09-2021	NOTES UPDATED	VB	LG	LG			CHECKED	TC	05/10/2011		
1	23/9/2021	DEPARTURE ANGLES REMOVED. DIMENSIONS & NOTES ADDED.	VB	LG	LG			APPROVED	TC	05/10/2011		
0	05/10/11	ISSUED FOR REVIEW	DJB	TC	TC			SCALE	NTS		TITLE HALF POST SPACING TWO WAY ROAD	DRAWING No. EZY-SM-018
								SIZE	A1			REV. 3

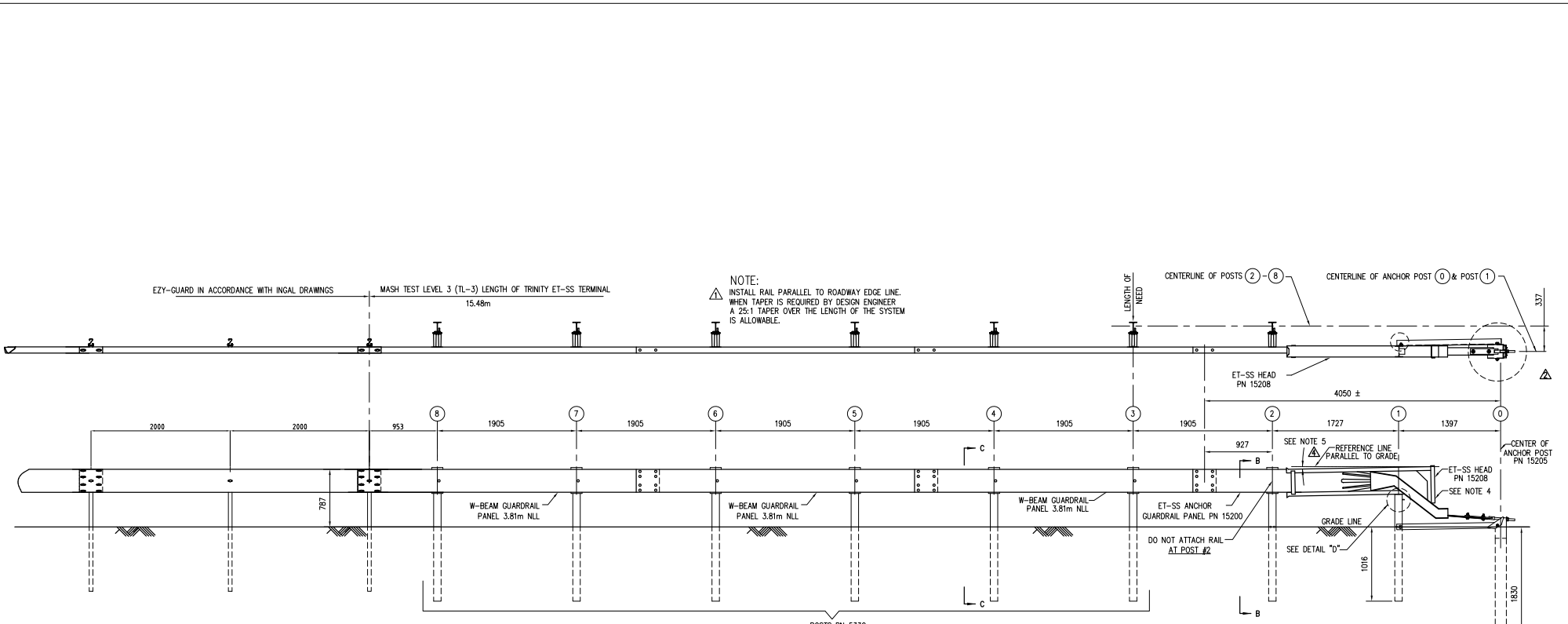

NOTE:
 INSTALL RAIL PARALLEL TO ROADWAY EDGE LINE. WHEN TAPER IS REQUIRED BY DESIGN ENGINEER A 25:1 TAPER OVER THE LENGTH OF THE SYSTEM IS ALLOWABLE.

- NOTES:**
- REFER TO ET-SS ASSEMBLY MANUAL.
 - ET-SS IS A MASH TEST LEVEL 3 (TL-3) END TREATMENT.
 - ALL STEEL COMPONENTS HDG TO AS/NZS4680.
 - DELINEATION OF TERMINAL TO BE IN ACCORDANCE WITH LOCAL AUTHORITY REQUIREMENTS.
 - IT IS ACCEPTABLE TO INSTALL THE ET-SS HEAD PARALLEL TO THE GRADE LINE OR WITH AN UPWARD TILT. SEE ET-SS ASSEMBLY MANUAL FOR SPECIFIC DETAILS.

REV	DATE	DESCRIPTION	DRAWN	CHECKED	APPROVED	DRAWING NUMBER	REFERENCE DRAWINGS	NAME	DATE	PROJECT	TITLE	INGAL CIVIL PRODUCTS PART No.	DRAWING No.
3	11/07/2022	BOM AND SECTION DETAILS REMOVED	LG	KZ	LG					DRAWING AND CONTENTS ARE COPYRIGHT TO INGAL CIVIL PRODUCTS AND CAN ONLY BE USED WITH PRIOR WRITTEN CONSENT FROM INGAL CIVIL PRODUCTS 57-65 AIRDS ROAD MINTO, N.S.W 2566 PH. +61 2 9827 3333 www.ingalcivil.com.au	MASH GUARDRAIL END TERMINALS ET-SS GUARDRAIL TRANSITION	10007556	SS-STD-002
2	04/02/2021	EZY-GUARD SECTION POST SPACING	VB	LG	LG								
1	27/05/2019	PRODUCT NAME UPDATED	VB	LG	LG								

SALES & MARKETING DRAWINGS SET-SS-STD-002 - ET-SS TRANSITION



For more information

contact us on the web

www.ingalcivil.com.au

Head Office: Sydney

57-65 Airs Road, Minto, NSW 2566

Ph: +61 2 9827 3333

Fax: +61 2 9827 3300

Local call (within Australia):

1300 446 425

Email: sales@ingalcivil.com.au

Our Locations:

• Adelaide/NT • Brisbane

• Melbourne • Newcastle

• Perth • Sydney • Wagga

• Auckland • Christchurch