



Ingal RBT

Rigid Barrier Transition

Product Manual



Release 02/24c

www.ingalcivil.com.au

1.0 Introduction

Roadside barriers are generally classified according to stiffness into one of three categories: flexible, semi-rigid, and rigid. If barriers have a dramatically different stiffness have to be joined together, a stiffness transition is usually required to reduce the risk of vehicle rollover, pocketing, or rail rupture.

The Ingal RBT is a MASH Test Level 3 compliant transition for connecting a range of semi-rigid barriers to a rigid concrete structure. It is available in a single sided configuration for verge applications or double sided configuration for gore or median applications.

The transition length for connecting Ezy-Guard 4 to the rigid structure is 6m and 8m for Ezy-Guard HC. The Ingal RBT has been crash tested when attached to the same rigid barrier as detailed in Austroads SBTA 21-005 Transition.

2.0 Specifications

| | |
|---------------------------|-------------------|
| Ingal RBT Post Length: | 1,830mm |
| Ingal RBT Post Mass: | 25kg |
| Ingal RBT System Mass: | 251kg |
| Rail Height Above Ground: | 880mm |
| Post Spacing: | Variable |
| Ingal RBT System Width: | 235mm |
| Containment Level: | MASH Test Level 3 |

The Ingal RBT is manufactured in Australia by Ingal Civil Products using steel manufactured by BlueScope Steel. Posts and rails are stamped providing traceability to material mechanical and chemical analysis certificates. Hot dip galvanising is performed internally by Ingal and daily inspections ensure zinc thickness readings are in accordance with AS/NZS standards.

State specific product acceptance details are available upon request from your local Ingal representative. Acceptance of product variants should be confirmed prior to installation.

MASH TL3 COMPLIANT



Ingal RBT Rigid Barrier Transition



ClawBolt M20 x 200mm
10010398

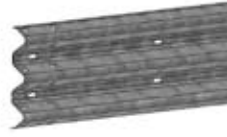

Thriebeam (2.7) 4m NLL 1m centres
10000849



Thriebeam (3.5) 4m NLL Bridge Approach
10000854



Thriebeam (2.7) 2m NLL 1m centres
10000865



W Beam to Thriebeam Transition 2m NLL
10000869



W-Beam Rail (2.7) 4m NLL 1m centers
10001020



Thriebeam Terminal Connector
10000659



M16 X 50 Post Bolt Grade 4.6
10001233



M16 Oversize Nut
10001239



M16 X 32 Splice Bolt
10001248



M16 x 30mm Ezy-Guard Carriage Bolt
10001832



Ezy-Guard HD Carriage
10004116



HD Z Post 2000mm
10005540



Ezy-Guard 4 Z-Post - 1650mm
10007390



W6x9 1830mm RBT I-beam Post
10010287



20NB Heavy Galv Pipe 185mm Long
10010580



200mm x 110mm U Block
10010579



200mm x 110mm U Block Short
10010583



M16 x 250 Post Bolt & Oversize Nut
10009787

3.0 How the Ingal RBT Works

A transition section is needed where a semi-rigid approach barrier is connected to a substantially stiffer downstream barrier. Transitions should produce a gradual stiffening of the overall approach barrier to reduce the risk of vehicle pocketing, snagging, or penetration at any position along the transition.

The Ingal RBT is a MASH Test Level 3 compliant transition for connecting a range of semi-rigid barriers to a rigid concrete structure.

The transition is 6m long and comprises a series of I-Beam posts at 1m and 0.5m spacing on the approach to the rigid structure. The transition posts are a common section used in guardrail end-terminals.

The posts support a 3.5mm BMT thrie-beam panel and a symmetric W-beam to thrie-beam transition panel.

Upon impact, the stiffness of the I-Beam resists lateral deflection of the rail, leading to the containment and redirection of the vehicle without excessive pocketing.

The upstream end of the transition can connect directly into the Ezy-Guard 4 system where the first 4m panel will have a reduced post spacing of 1m.

Alternatively, the transition can connect to the Ezy-Guard HC and LDS systems, with the height discrepancy transitioned over two thrie-beam panels.

Refer installation drawings to the end of this manual for more detail.

The Ingal RBT has been crash tested when attached to the same rigid barrier as detailed in Austroads SBTA 21-005 Transition.

3.1 System Width

The Ingal RBT has a system width of 235mm when installed in the single sided configuration. This narrow width allows for greater flexibility when trying to avoid conflicts with under ground services

4.0 Crash Test Analysis

Crash test guidelines provide a minimum set of requirements that a roadside barrier has to meet in order to demonstrate its satisfactory impact performance.

Whilst crash test guidelines cannot include all possible impact conditions that may be experienced in the real world, the crash test matrix is selected to represent a "worst practical condition" for a roadside barrier impact.

The Ingal RBT has been fully crash tested and evaluated according to the specifications for Test Level 3 (TL3) of the AASHTO Manual for Assessing Safety Hardware (MASH).

In the revised standard AS/NZS 3845.1:2015, MASH has been nominated as the basis of testing procedures for road safety barrier systems.

The MASH TL3 crash test matrix requires the following impacts;

- Test 3-20, this is an 1,100kg car travelling at 100km/h and impacting the barrier at 25 degrees. This test is to evaluate the occupant risk and post-impact trajectory for small vehicle impacts.
- Test 3-21 is the capacity test, this is a 2,270kg utility travelling at 100km/h and impacting the barrier at 25 degrees. This test is to evaluate the strength of the barrier in containing and redirecting large utility style vehicles.

Crash test impact conditions are defined by the mass, speed, and angle of the impacting vehicle. Crash test standards and performance levels can be compared by calculating the impact severity (IS).

$$IS = \frac{1}{2} M (V \sin \theta)^2$$

Where IS is the impact severity in joules (J), M is the test inertial mass of the vehicle in kilograms (kg), V is the impact speed in metres/second (m/s) and θ is the impact angle in degrees.

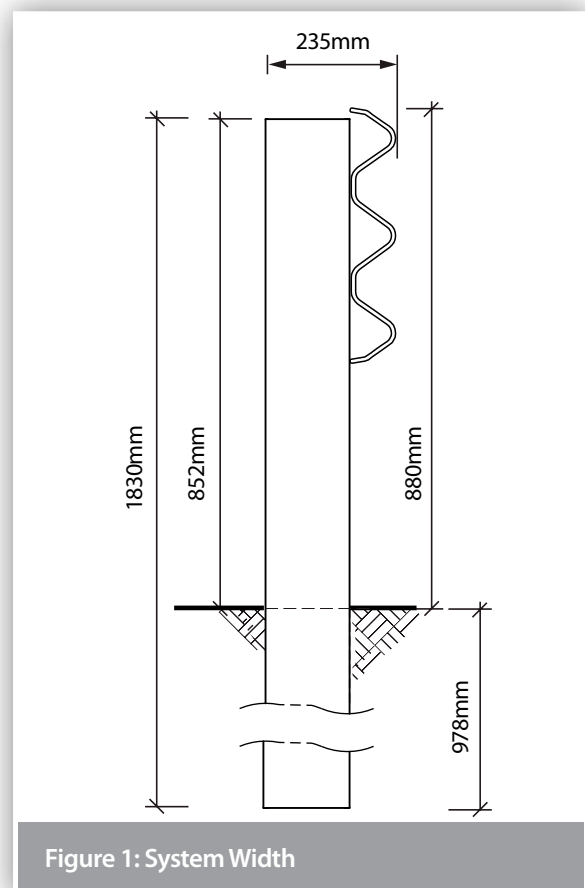

Figure 1: System Width

5.0 Installation

5.1 Minimum Length Requirements

There are two geometric methods used to determine the likely trajectory of a vehicle that leaves the road in the vicinity of a roadside hazard and the minimum length of barrier required to protect from this hazard.

The most common method is the run-out length method and an alternative is a method based on angle of departure.

Prior to design or installation, designers should consult the relevant road controlling authority to establish the local jurisdictional practice as the methods may result in different lengths. Both methods are detailed in the Austroads Guide to Road Design – Part 6.3.

For instances where geometric constraints limit the installation of the recommended length under these methods, the absolute minimum length of need for the run of barrier is dependent on the design containment level. Please refer to the safety barrier product manual for these system specific values.

5.2 Sequence of Work

Where the Ingal RBT is being constructed on a road open to traffic, it is recommended that the work commence at the end closest to the approaching traffic. Leading terminals and transitions shall be commissioned at the earliest practical time.

5.3 Modifications

The Ingal RBT shall be constructed in the configuration as detailed in Ingal Civil Products' drawings. This is the configuration in which the system has been crash tested.

No modifications shall be made to the system unless verified by Ingal Civil Products.

Flame cutting of rails or posts is not permitted. Saw cutting and drilling is permitted in the event that a post is to be installed at an irregular spacing and/or rock is encountered and the post embedment depth has been modified.

Any modification carried out after fabrication will require repair to the galvanized coating. This is undertaken by applying two coats of an organic zinc rich epoxy paint complying with AS/NZS 3750.9. This is to be applied to the repair areas in two coats. Each coat shall have a minimum dry film thickness of 50 µm.

5.4 Soil Requirements & Embedment Depth

The Ingal RBT posts are designed to yield by bending near ground level during impact. Provided the post is embedded in material that allows this failure mechanism to be replicated, the transition functionality will be retained. The Z-posts will provide lateral resistance until the impacting vehicle causes deformation of the posts.

The Ingal RBT has been evaluated for installation in standard soil in accordance with AASHTO standard specifications for 'Materials for Aggregate and Soil Aggregate Subbase, Base and Surface Courses,' designation M147.

5.5 Delineation

A specially designed delineator is attached to the post. Typically, delineation is arranged so that drivers approaching from either direction will see only:

- Red retro-reflectors on their left;
- White retro-reflectors on their right on two-way carriageways; and
- Yellow retro-reflectors on their right on one-way carriageways and medians separating traffic in opposing directions.

The spacing of delineators is dependant upon driver line of sight. As a general rule delineators are provided for installation every 20m on straight alignments. Please refer to the asset owners specifications for further guidance.

5.6 Curving of Rails

Curving of the three-beam rails within the Ingal RBT is not permitted. If additional offset of the barrier is required and the rigid structure cannot be moved, the offset should be attained in the longitudinal barrier.

5.7 Slopes

The maximum cross fall for an installation of the Ingal RBT is 10H:1V (10%).

Proximity to a batter slope will depend on the required containment level and batter gradient. For a TL3 containment, the posts can be installed up to 500mm from the rounding point for batter gradients no steeper than 2H:1V.

6.0 Installation Sequence

The following written instructions should be read in conjunction with Ingal Civil Products' drawings.

A generic Safe Work Method Statement is available from Ingal Civil Products to assist in the safe installation of the Ingal RBT.

Only items purchased from Ingal Civil Products shall be used for the construction of transition.

1. Ensure the area has been inspected for underground hazards and that suitable traffic control is in place.
2. Post locations are marked with the varying post spacing in accordance with the drawings to the end of this manual. Note, any fixed object hazard should be located outside the expected dynamic deflection of the barrier. The single sided configuration has a system width of 235mm.
3. Posts are driven directly into the ground and should be vertical. The post installation process shall not cause damage to the post, such that it reduces the effective operation of the safety barrier or its design life, or introduces sharp tearing edges, nor shall it cause damage to pavement. The use of a vibrating post hammer will reduce deformation to the top of the post and install the post at a controlled rate.
4. Alternate to driving the posts, a minimum 200-300mm hole can be augured and the post placed in the hole. The posthole is then backfilled with the material that was excavated. If installing in soil, the material should be placed in layers of 150mm and suitably compacted to not less than the density of the surrounding layers.
5. The height of posts 1 thru 6 is 852mm above ground level.
 - When connecting to Ezy-Guard 4, the height of post 7 is 814mm and post 8 is 756mm above ground level.
 - When connecting to Ezy-Guard HC, posts 7 thru 10 will gradually increase in height to bring the rail height up to 980mm. Refer drawing RBT-STD-007 and 008 for more detail.
6. For the median configuration, secure the C section blocks to posts 4, 6 and 8 with the M16x250 bolts and NB20 CHS pipe.
7. The first rail is a 3.5mm BMT thrie-beam panel and this is attached to posts 1 thru 6 using the M16 x 50mm mushroom head bolts. The bolts are tightened to snug tight.
 - When connecting to Ezy-Guard 4, the symmetric W-Beam to Thrie-Beam panel is mounted between posts 6 and 8.
8. Rails are spliced together using M16x32mm mushroom head bolts and oversized nuts. There are twelve bolts required per splice connection. A pinch bar may be used to assist in the alignment of splice holes. The use of a driving pin to elongate the slots is NOT to be used since this may cause tearing of the rail at the slot location. The bolts are tightened to snug tight.

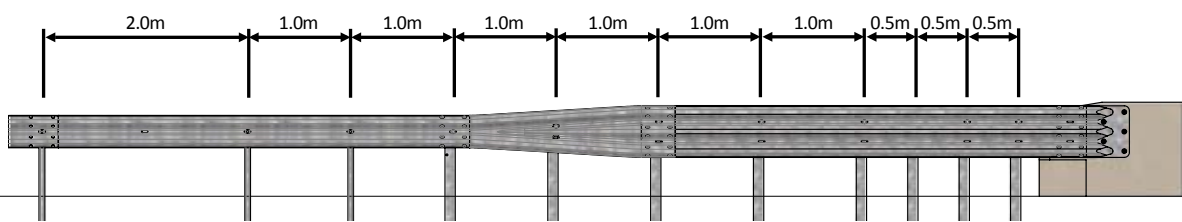

Figure 2: Transition to Ezy-Guard 4.

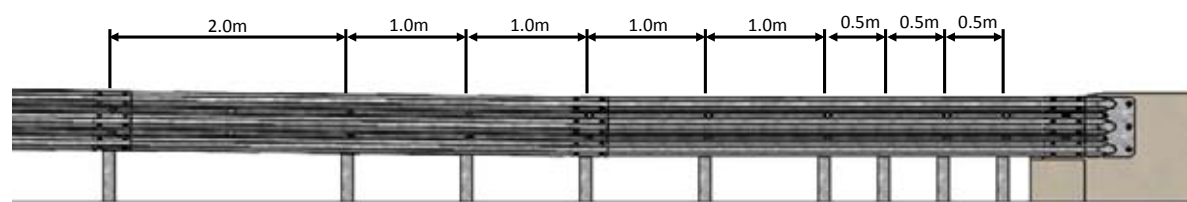

Figure 3: Transition to Ezy-Guard HC.

9. Rails are orientated so that no leading edge is presented to the traffic face as shown in Figure 18.
10. It is recommended that posts be installed only a few metres ahead of rail assembly to ensure correct post spacing and alignment.
11. The first rail is connected to the concrete via the thrie-beam structural connector. The lapping of the splice joint should follow figure 5 and uses twelve M16x32 splice bolts/nuts.

The structural connector is fixed to the concrete via six M20x140 Hobson EAW-GD Clawbolt Anchor Through Bolt. Installation of these anchor bolts should be in accordance with the manufacturer's instructions.

12. The construction of Ingal RBT shall form a smooth line vertically and horizontally when viewed along the line of the system, free from humps, sags or other irregularities.
13. The Ingal RBT components are to be free from splits, burrs or sharp edges after installation. Any minor damage is to be repaired in accordance with section 5.4.
14. Any disturbed pavement or material around a post shall be left dense, tight, and smooth so that resistance to water penetration is similar to that of the adjacent surface.

6.1 Installation Tolerances

- The tolerance on height of the barrier shall be plus or minus 20mm.
- The tolerance for the line of the barrier shall be plus or minus 20mm in plan view.
- The tolerance for departure from the upright axis shall be plus or minus 15mm at the top of the barrier.
- The tolerance on post spacing shall be plus or minus 25mm.



Figure 4: Structural connector to concrete

7.0 Maintenance

It is recommended that annual inspections be performed to ensure the following;

- The system is appropriately delineated;
- Debris has not accumulated around the system that may impede the performance of the barrier or the trajectory of an impacting vehicle;
- The system is suitably anchored with appropriate terminals and/or transitions. If the system is anchored with terminals, the cable assembly shall be taut and tensioned to its recommended value; and
- All splice bolts and post bolts are snug tight.

8.0 Product Storage

All posts and rails are hot dip galvanized in accordance with AS/NZS 4680. It is important that stored galvanized work is stacked so that each item is well ventilated and can adequately drain rainwater from its surfaces.

Poor storage can give rise to wet storage stain (white rust) which is caused by water (rain or condensation) in badly drained or ventilated conditions. This can occur very quickly, particularly in warm, humid conditions.

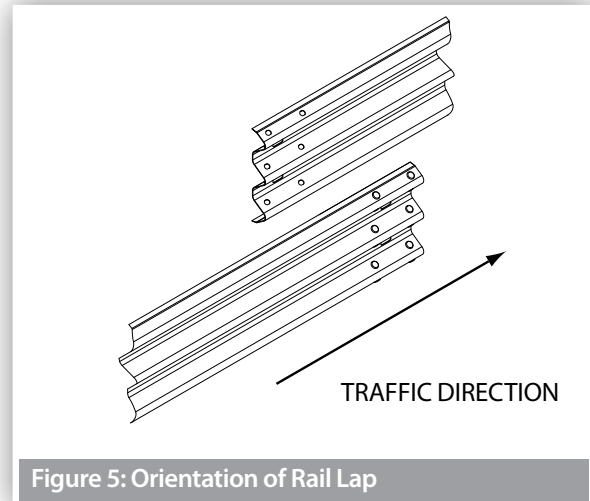

Figure 5: Orientation of Rail Lap

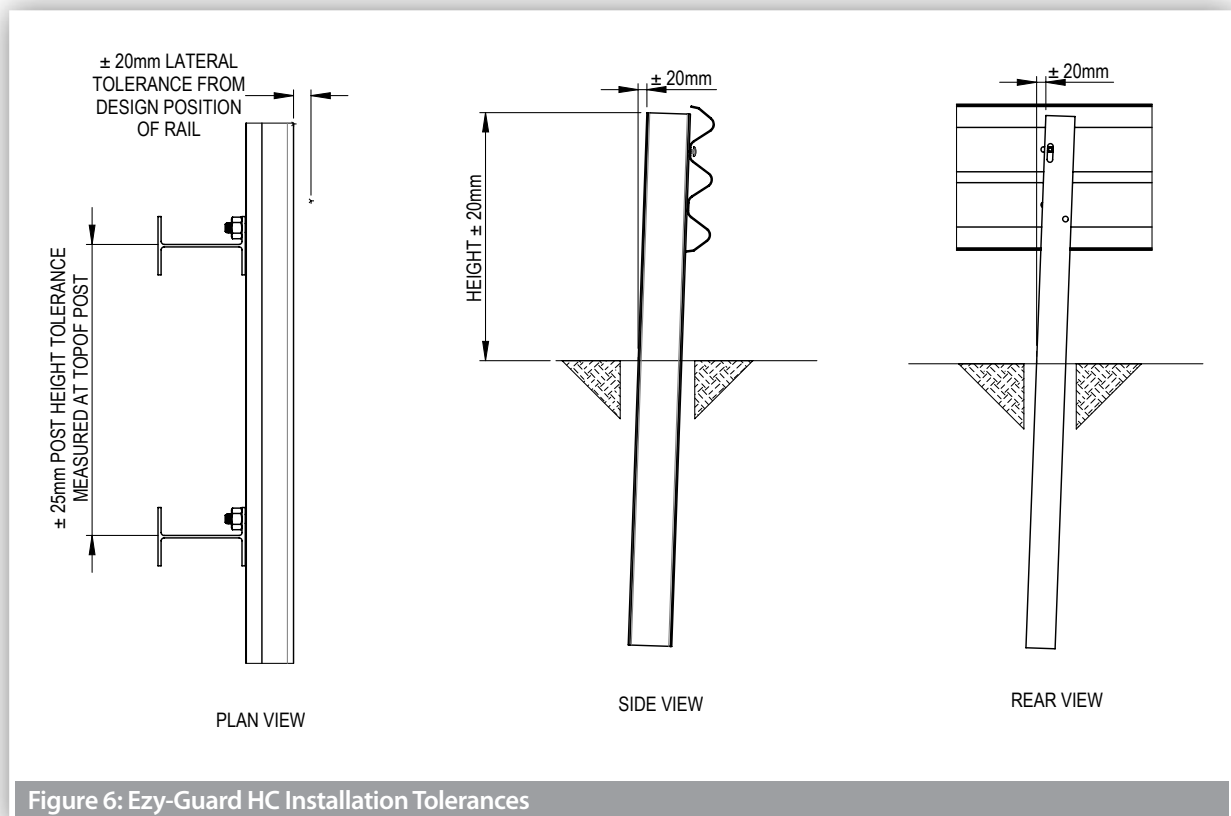

Figure 6: Ezy-Guard HC Installation Tolerances

Ingal RBT Installation Checklist

Customer:

Project:

Barrier ID:

Barrier Length:

Checked By:

Signed:

Date

| | | |
|--|------------------------------|-----------------------------|
| Have the posts been positioned in accordance with the Ingal RBT drawings | <input type="checkbox"/> Yes | <input type="checkbox"/> No |
| Is the first Thrie-Beam rail the correct thickness of 3.5mm BMT | <input type="checkbox"/> Yes | <input type="checkbox"/> No |
| Posts are installed to the correct height (852mm) and within the tolerances of section 7.14 | <input type="checkbox"/> Yes | <input type="checkbox"/> No |
| Is the first rail bolted to the post at locations 1, 2, 4, 5 and 6 | <input type="checkbox"/> Yes | <input type="checkbox"/> No |
| The first rail is NOT bolted to posts 3 | <input type="checkbox"/> Yes | <input type="checkbox"/> No |
| Have the rails been spliced observing the correct lap | <input type="checkbox"/> Yes | <input type="checkbox"/> No |
| Have the rails been spliced with M16x32mm mushroom head bolts and tightened to snug | <input type="checkbox"/> Yes | <input type="checkbox"/> No |
| Have the concrete anchors been installed in accordance with the manufacturers instructions | <input type="checkbox"/> Yes | <input type="checkbox"/> No |
| Is the upstream end of the run of barrier anchored with approved terminal | <input type="checkbox"/> Yes | <input type="checkbox"/> No |
| Where applicable, is the terminal cable tensioned to it's nominated torque (taut) | <input type="checkbox"/> Yes | <input type="checkbox"/> No |
| Has any minor damage been repaired using two coats of an organic zinc rich paint | <input type="checkbox"/> Yes | <input type="checkbox"/> No |
| Does the barrier form a smooth line vertically and horizontally when viewed along the system | <input type="checkbox"/> Yes | <input type="checkbox"/> No |
| Is the barrier system free from humps, sags or other irregularities | <input type="checkbox"/> Yes | <input type="checkbox"/> No |
| Has the ground or pavement around the post been left dense, tight and smooth | <input type="checkbox"/> Yes | <input type="checkbox"/> No |
| Are the barrier components free from splits, burrs or sharp edges after installation | <input type="checkbox"/> Yes | <input type="checkbox"/> No |

Disclaimer:

Important Note: The conformity of the installation is the responsibility of the installation contractor, and Ingal Civil Products accepts no liability for or in connection with any installation that is outside of the specifications of this manual or the Road Controlling Authority. For more information, please refer to our Standard Terms and Conditions of Sale available on our website: www.ingalcivil.com.au.

10.0 Repair

10.1 Bush Fire Damage

The Ingal RBT does not contain any plastic, timber or rubber components that will burn.

The performance of galvanized coatings when subjected to fires depends upon a number of factors, such as flame duration and intensity.

Typical bushfire conditions may expose steel structures to an air temperature of 800°C for periods of up to 120 seconds, however zinc coatings are generally reflective and will not absorb heat at the same rate as an uncoated steel surface. Depending on the section thickness of the steel, the actual steel surface temperature may not exceed 350°C.

Typically, the bushfire flame duration and intensity are not high enough to compromise the structural strength of the steel. The hot dip galvanized coating will also typically remain unaffected through a bushfire event. If the bushfire causes damage to the galvanized surface, then the item(s) shall be replaced.

10.2 Damage Assessment

In the event of a vehicle impact, damage to the barrier is to be assessed in accordance with Table 3.

A Safe Work Method Statement is available from Ingal Civil Products upon request to assist in the safe repair of the Ingal RBT.

Any item that is replaced is to be reinstated observing the installation tolerances nominated in Section 7.11. Only items purchased from Ingal Civil Products shall be used for the repair of transition.

10.3 Dismantling Sequence

Prior to undertaking dismantling due to a vehicle impact, the area should be assessed for hazards. These include trip hazards, sharp edges and snag points.

During a vehicle impact, the rail will disengage from the posts as they yield by bending at ground level. The recommended dismantling sequence is as follows;

1. Dismantle the rail splice by removing the M16x32mm mushroom head bolts and nuts. There are 8 bolts located at each splice location.
2. Rails that are still attached to posts outside the impact area are disconnected by removing the M16 post bolt.
3. Once the area is clear of damaged rail, the posts can be removed. Since the posts yield by bending near ground level, a sling or chain can be attached below the bent section.
4. The damaged post can be lifted using a backhoe or post extractor attachment.
5. Any disturbed pavement material shall be left dense, tight, and smooth prior to the installation of replacement posts.
6. Rails, posts and carriages to be disposed of, should be recycled at a ferrous scrap recycling facility.

Table 3: Damage Assessment of Ezy-Guard HC

| Type of Defect | Description of the Defect | Action to be Taken |
|--------------------------------------|---|--|
| Galvanizing damage on Z-Posts. | The sum total of the damaged area does not exceed 35cm ² (0.5% of the total surface area). The sum total of the damaged area exceeds 35cm ² | An organic zinc rich epoxy paint is to be applied to the repair area in two coats as per section 5.4. The Z-post is to be replaced. |
| Galvanizing damage on rails. | The sum total of the damaged area does not exceed 200cm ² (0.5% of the total surface area) and no individual damaged area does not exceed 40cm ² . The sum total of the damaged area exceeds 200cm ² (0.5% of the total surface area) and/or an individual damaged area exceeds 40cm ² . | An organic zinc rich epoxy paint is to be applied to the repair area in two coats as per section 5.4. The rail is to be replaced. |
| Mechanical damage on Z-Posts. | The post is bent. The post is twisted. | The post is to be replaced. The post is to be replaced. |
| Mechanical damage on rail. | The rail is dented, twisted or flattened. There are tears in any part of the rail. The slots in the rail are distorted. | The rail is to be replaced. The rail is to be replaced. The rail is to be replaced. |
| Mechanical damage on bolts. | The body of the bolt is distorted. The thread of the bolt is damaged. | The bolt is to be replaced. The bolt is to be replaced. |
| Disturbance of material around posts | The material around the post is loose or uncompacted. | Any disturbed pavement or material around a post shall be left dense, tight and smooth so that resistance to water penetration is similar to that of the adjacent surface. |

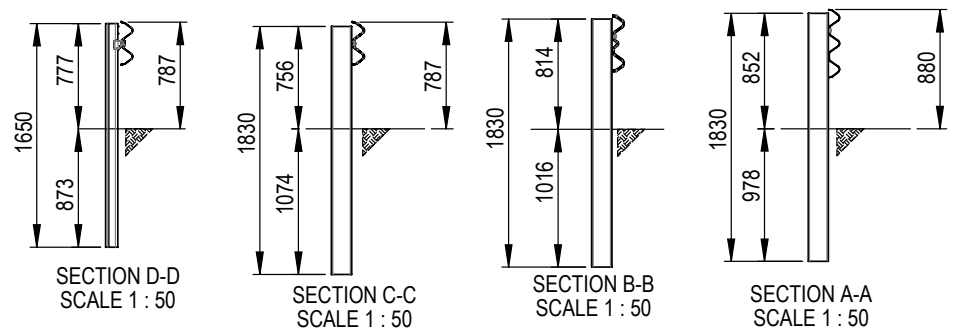
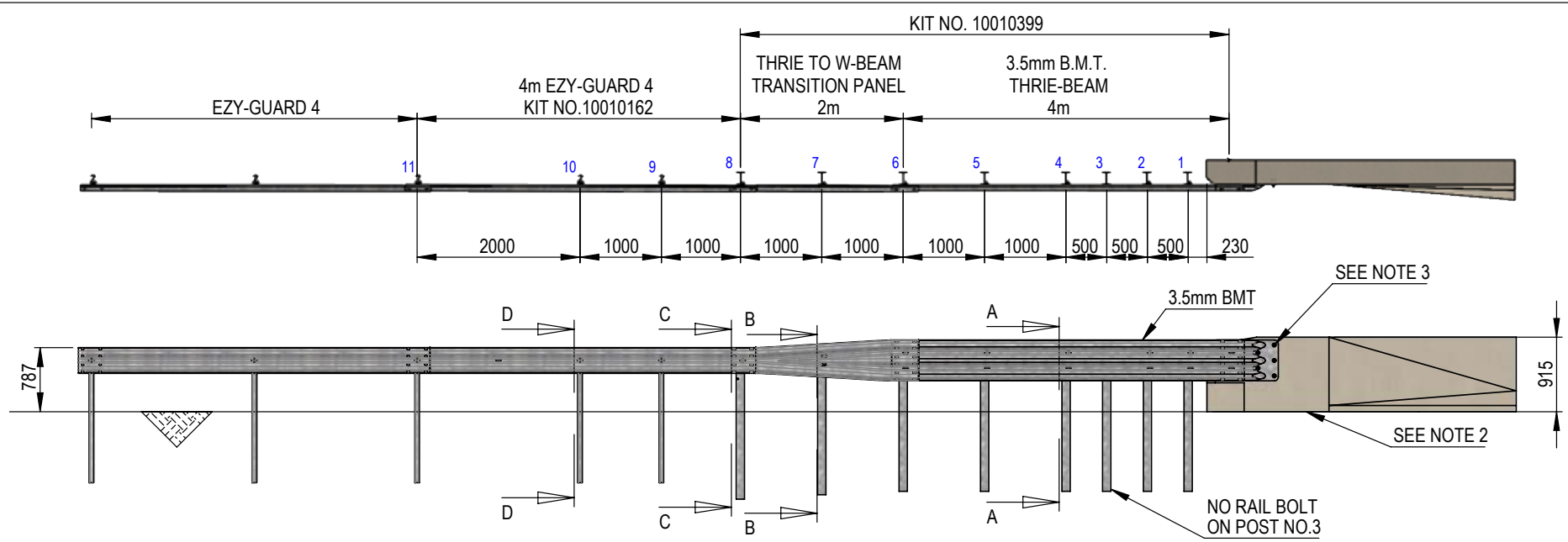

- NOTE:**
1. REFER TO EZY-GUARD 4 MANUAL STANDARD EZY-GUARD 4 INSTALLATION
 2. CONCRETE BARRIER TO BE CONSTRUCTED IN ACCORDANCE WITH SBTA 21-005 SHEET 5 AND 7
 3. THE STRUCTURAL CONNECTOR IS FIXED TO THE CONCRETE VIA FIVE M20 x 200 HOBSON EAW-GD CLAWBOLT. INSTALLATION SHALL BE IN ACCORDANCE WITH THE MANUFACTURER'S INSTRUCTION

| | | | | | | | | | | | | | |
|-----------|------|-------------|------------------------------|---------|----------|------------|----|----------------|---------------------------|------|---|---------|---|
| REVISIONS | | | | | | REFERENCES | | | DRAWN KZ 17-02-2023 | DATE | | PROJECT | INGAL CIVIL PRODUCTS PART No. 10010399 |
| | 1 | 4/05/2023 | UPDATED FINISHING KIT NUMBER | KZ | LG | | LG | DRAWING NUMBER | | | | | |
| REV. | DATE | DESCRIPTION | DRAWN | CHECKED | APPROVED | | | ISSUE FOR | | | 57-65 AIRDS ROAD MINTO, N.S.W 2566 PH: +61 2 9827 3333 www.ingalcivil.com.au | | Rev. 1 |

FOLDER: F:\ENGINEERING\3 - CURRENT DRAWINGS\COMPONENT DRAWINGS\LDORVIS_SOLID MODEL\INGAL RBT\CURRENT\TY_MODEL1

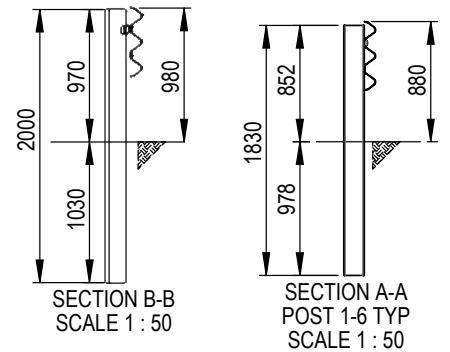
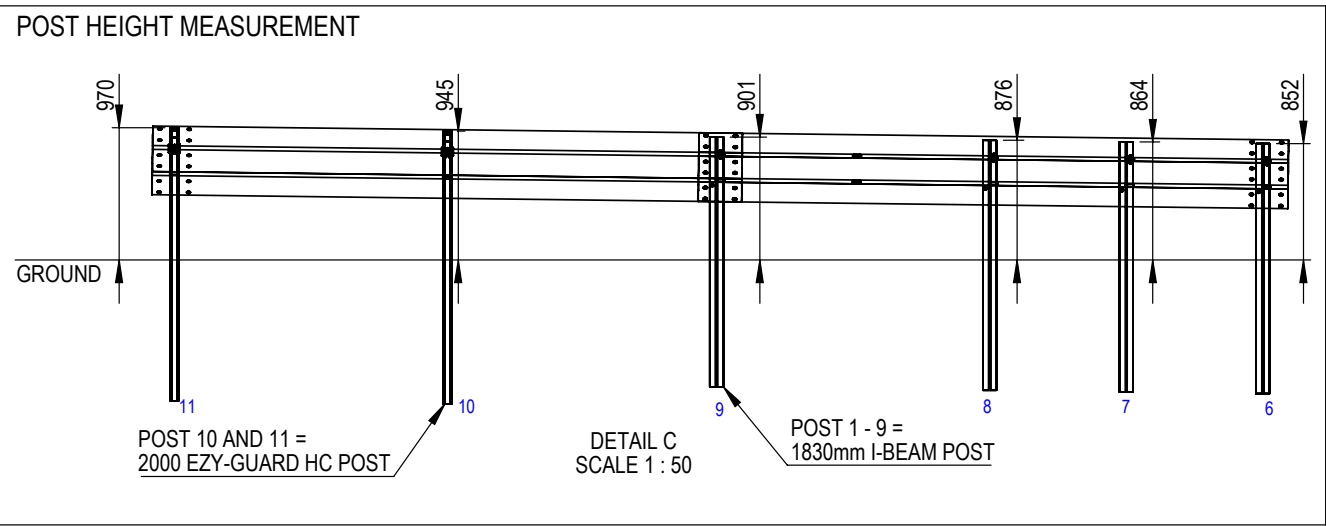
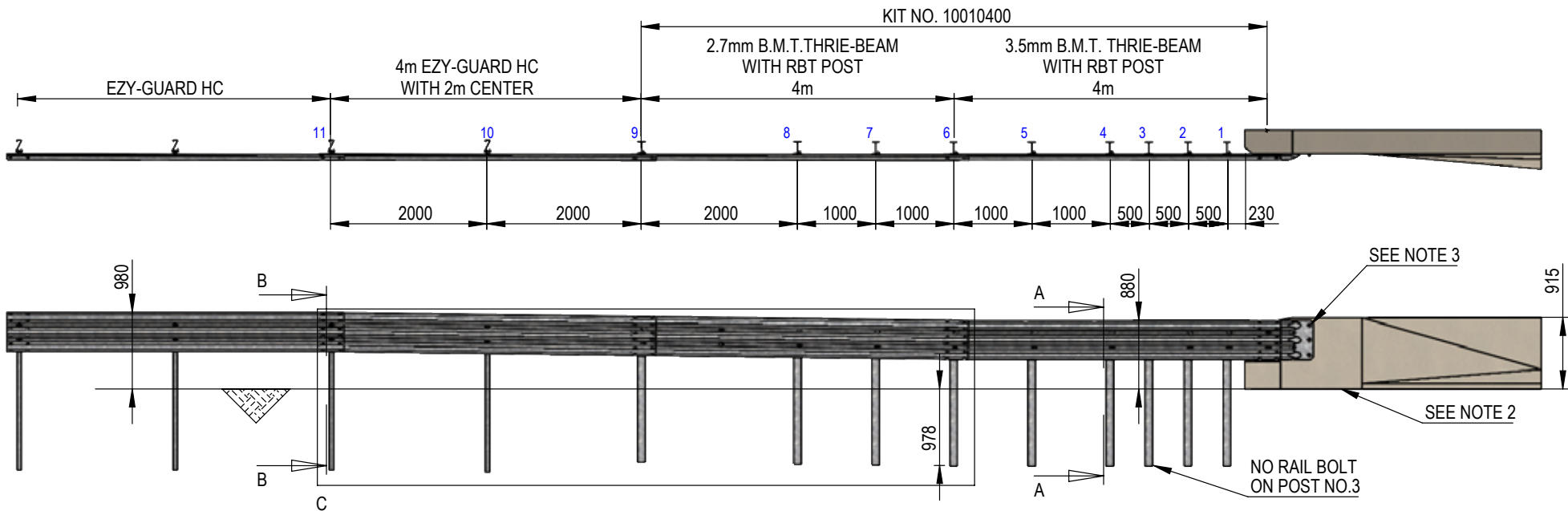

- NOTE:**
- REFER TO EZY-GUARD 4 MANUAL STANDARD EZY-GUARD 4 INSTALLATION
 - CONCRETE BARRIER TO BE CONSTRUCTED IN ACCORDANCE WITH SBTA 21-005 SHEET 5 AND 7 THE STRUCTURAL CONNECTOR IS FIXED TO THE CONCRETE VIA FIVE M20 x 200 HOBSON EAW-GD CLAWBOLT. INSTALLATION SHALL BE IN ACCORDANCE WITH THE MANUFACTURER'S INSTRUCTION
 -

| | | | | | | |
|------------|----------------|--------------------|-------------|-------|----------------------|--|
| REVISIONS | REV. | DATE | DESCRIPTION | DRAWN | CHECKED | APPROVED |
| | | | | | | |
| REFERENCES | DRAWING NUMBER | REFERENCE DRAWINGS | NAME | DATE | INGAL CIVIL PRODUCTS | |
| | | | | | PART No. 10010400 | |
| | | | DRAWN | KZ | 17-02-2023 | DRAWING AND CONTENTS ARE COPYRIGHT TO INGAL CIVIL PRODUCTS AND CAN ONLY BE USED WITH PRIOR WRITTEN CONSENT FROM INGAL CIVIL PRODUCTS |
| | | | CHECKED | LG | 17-02-2023 | |
| | | | APPROVED | LG | 17-02-2023 | PROJECT TITLE INGAL RBT TO EZY-GUARD HC - 8m LHS APPROACH |
| | | | SCALE | 1:70 | SHEET: 1 of 3 | |
| | | | ISSUE FOR | | | DRAWING No. RBT-STD-007 |
| | | | | | | Rev. 0 |

FOLDER: C:\BERSK\Z71794\DESKTOP\KZ LOCAL FILES\RBT MODEL CLEANUP\MANUAL MODEL

| ID | DESCRIPTION | PART NO. | QTY. |
|----|---|----------|------|
| 1 | THRIEBEAM TERMINAL CONNECTOR | 10001174 | 2 |
| 2 | THRIEBEAM (3.5) 4000mm NLL BRIDGE APPROACH | 10000854 | 2 |
| 3 | EZY-GUARD SMART CARRIAGE | 10004115 | 11 |
| 4 | W6 x 9 RBT POST - 1830mm | 10010287 | 8 |
| 5 | M16 X 50mm POST BOLT GRADE 4.6 | 10001233 | 7 |
| 6 | M16 OVERSIZE NUT | 10001239 | 106 |
| 7 | M16 x 30mm EZY-GUARD SMART POST BOLT | 10001832 | 11 |
| 8 | 200mm x 110mm U BLOCK | 10010579 | 2 |
| 9 | M16 x 250mm TERMINAL BOLT | 10009787 | 3 |
| 10 | M16 x 40mm H/T HEX HEAD BOLT/NUT & WASHER GALV | 10004513 | 3 |
| 11 | 20NB HEAVY GALV PIPE 185mm LONG | 10010580 | 3 |
| 12 | 200mm x 110mm U BLOCK SHORT - RBT MEDIAN | 10010583 | 1 |
| 13 | W Beam to Thriebeam Transition 2000mm NLL - 2.7 BMT | 10000869 | 2 |
| 14 | W-BEAM RAIL (2.7mm BMT) 4000 NLL 500 CENTERS | 10005590 | 4 |
| 15 | CLAWBOLT EAW-GD M20 x 200mm | 10010398 | 10 |
| 16 | M16 X 32 SPLICE BOLT GRADE 8.8 | 10001248 | 96 |
| 17 | MEDIAN Z POST SMART 1650mm | 10007562 | 1 |
| 18 | EZY-GUARD 4 Z-POST | 10007390 | 9 |

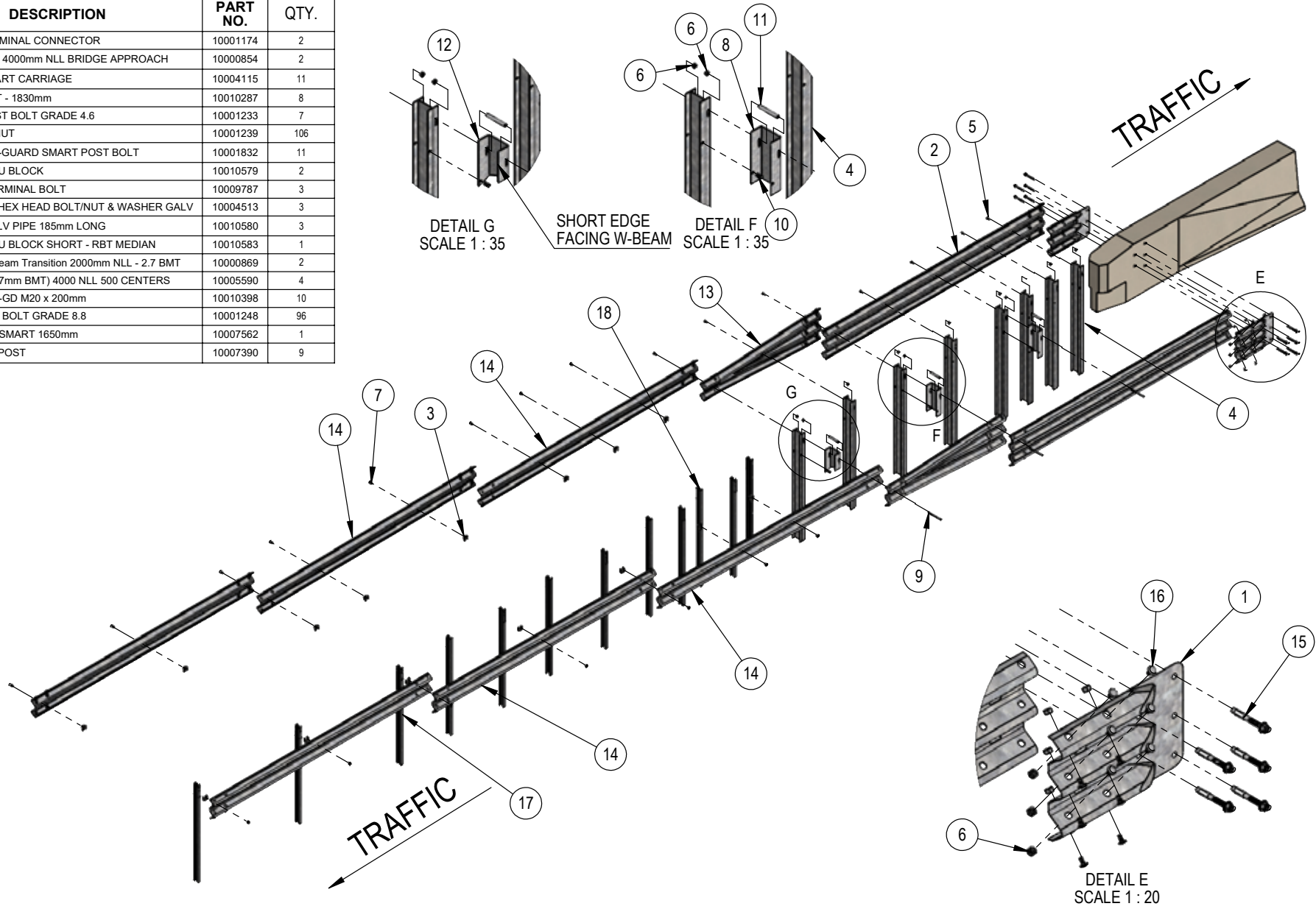

| REV. | DATE | DESCRIPTION | DRAWN | CHECKED | APPROVED |
|------|------------|-----------------------------------|-------|---------|----------|
| 1 | 17/08/2023 | UPDATED PART NUMBERS IN BOM TABLE | KZ | LG | LG |

| REFERENCES | DRAWING NUMBER | REFERENCE DRAWINGS |
|------------|----------------|--------------------|
| | | |
| | | |
| | | |
| | | |

| | NAME | DATE |
|-----------|------|---------------|
| DRAWN | KZ | 15-08-2023 |
| CHECKED | LG | 15-08-2023 |
| APPROVED | LG | 15-08-2023 |
| SCALE | 1:70 | SHEET: 2 of 3 |
| ISSUE FOR | | |

INGAL CIVIL PRODUCTS
a valmont COMPANY

DRAWING AND CONTENTS ARE COPYRIGHT TO
 INGAL CIVIL PRODUCTS AND CAN ONLY BE USED
 WITH PRIOR WRITTEN CONSENT FROM INGAL CIVIL
 PRODUCTS

57-45 AIRDS ROAD
 MINGO, N.S.W 2566
 PH: +61 2 9627 3333
 www.ingalcivil.com.au

| PROJECT | TITLE |
|---------|---|
| | INGAL RBT TO MEDIAN EZY-GUARD 4 - EXPLODED VIEW |

| INGAL CIVIL PRODUCTS PART No. | DRAWING No. |
|-------------------------------|-------------|
| 1000XXXX | RBT-STD-005 |

Rev: 1

FOLDER F:\ENGINEERING\3. CURRENT DRAWINGS\COMPONENT DRAWINGS\SS\DRWS\L_SOLID MODEL\INGAL RBT\CURRENT\T\L_MODEL

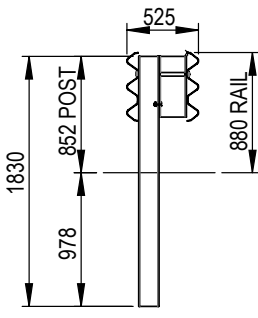
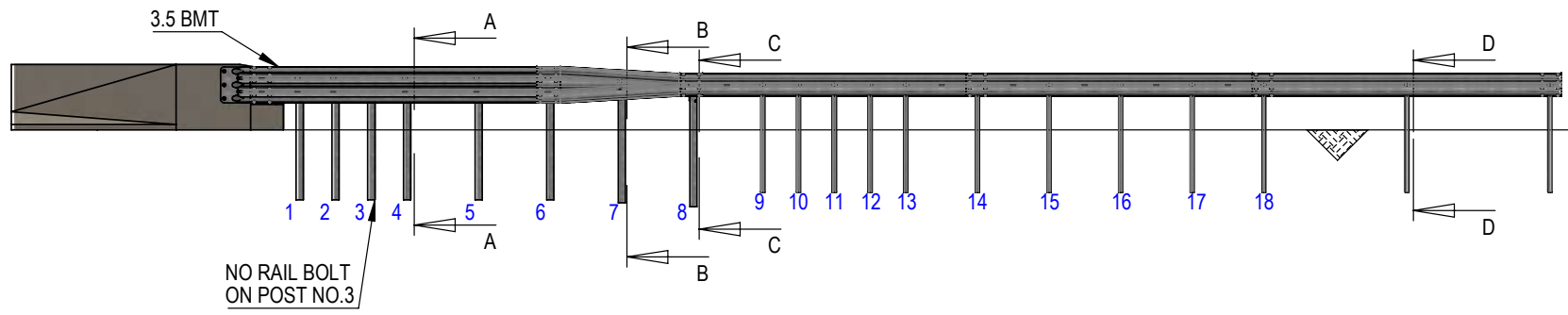
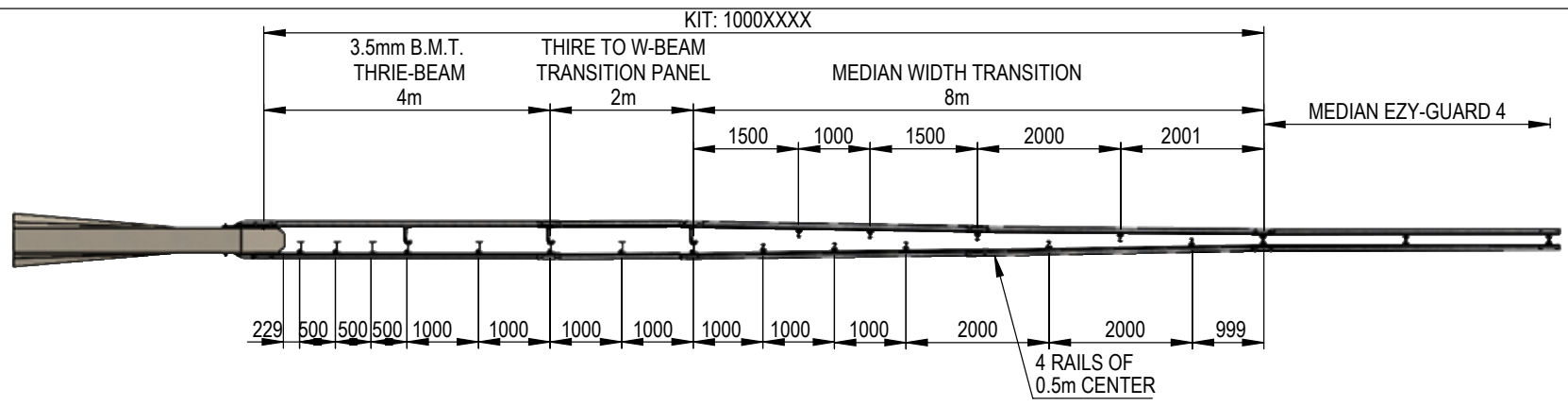

SECTION A-A
SCALE 1 : 50

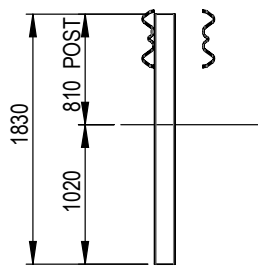

SECTION B-B
SCALE 1 : 50

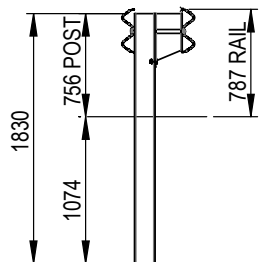

SECTION C-C
SCALE 1 : 50

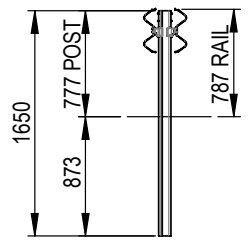

SECTION D-D
SCALE 1 : 50

- NOTE:**
1. REFER TO EZY-GUARD 4 MANUAL FOR STANDARD EZY-GUARD 4 INSTALLATION
 2. CONCRETE BARRIER TO BE CONSTRUCTED IN ACCORDANCE WITH SBTA 21-005 SHEET 5 AND 7
 3. THE STRUCTURAL CONNECTOR IS FIXED TO THE CONCRETE VIA FIVE M20 x 200 HOBSON EAW-GD CLAWBOLT. INSTALLATION SHALL BE IN ACCORDANCE WITH THE MANUFACTURER'S INSTRUCTION

| | | | | | | | | | | | | | | |
|-----------|------|------|-------------|------------|--|----------|--------|----|---|--|--|--|--|--|
| REVISIONS | 1 | | | 30/11/2023 | ADDED DESCRIPTION FOR POST RAIL HEIGHT DIMENSION | KZ | LB | KZ | REFERENCES DRAWING NUMBER REFERENCE DRAWINGS ISSUE FOR | NAME DRAWN KZ CHECKED LG APPROVED LG SCALE 1:90 SHEET: 1 of 3 | DATE 15-08-2023 15-08-2023 15-08-2023 | DRAWING AND CONTENTS ARE COPYRIGHT TO INGAL CIVIL PRODUCTS AND CAN ONLY BE USED WITH PRIOR WRITTEN CONSENT FROM INGAL CIVIL PRODUCTS 57-65 AIRDS ROAD HUNTCO, N.S.W 2564 PH. +61 2 9627 3333 www.ingalcivil.com.au | PROJECT INGAL RBT TO MEDIAN EZY-GUARD 4 - 14M | INGAL CIVIL PRODUCTS PART No. 1000XXXX DRAWING No. RBT-STD-004 |
| | REV. | DATE | DESCRIPTION | DRAWN | CHECKED | APPROVED | Rev. 1 | | | | | | | |

FOLDER: F:\ENGINEERING4 - DRAWINGS IN PROGRESS\ SOLIDWORKS MODEL IN PROGRESS\INGAL RBT\CURRENT\T_MODEL1

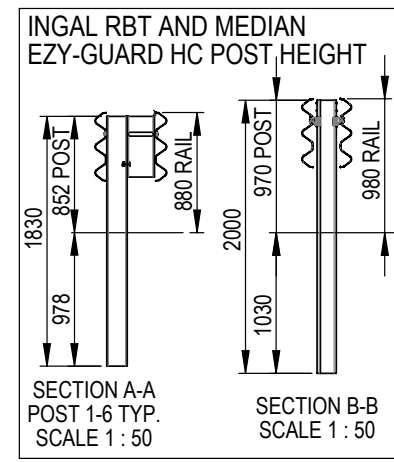
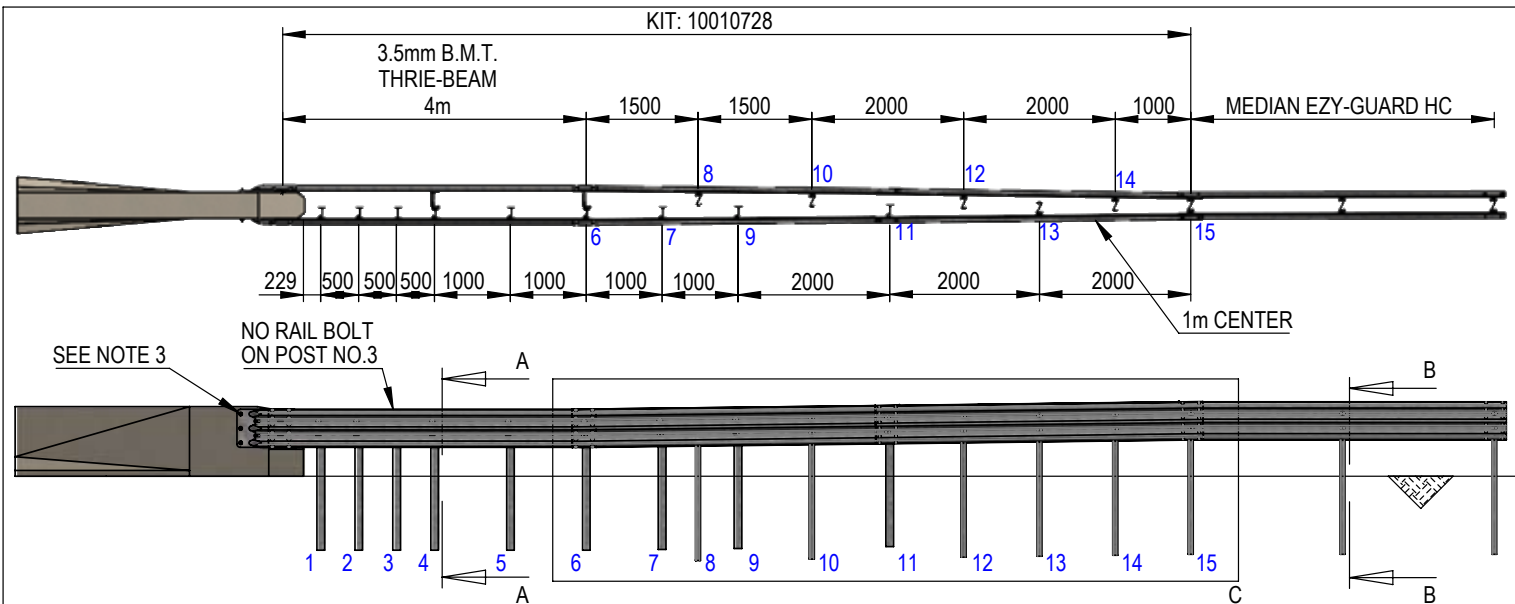

- NOTE:**
- REFER TO EZY-GUARD HC MANUAL FOR MEDIAN EZY-GUARD HC INSTALLATION
 - CONCRETE BARRIER TO BE CONSTRUCTED IN ACCORDANCE WITH SBTA 21-005 SHEET 5 AND 7
 - THE STRUCTURAL CONNECTOR IS FIXED TO THE CONCRETE VIA FIVE M20 x 200 HOBSON EAW-GD CLAWBOLT. INSTALLATION SHALL BE IN ACCORDANCE WITH THE MANUFACTURER'S INSTRUCTION
 - POST 8, 10, 12, 13, 14, 15 ARE STANDARD EZY-GUARD HC Z POST

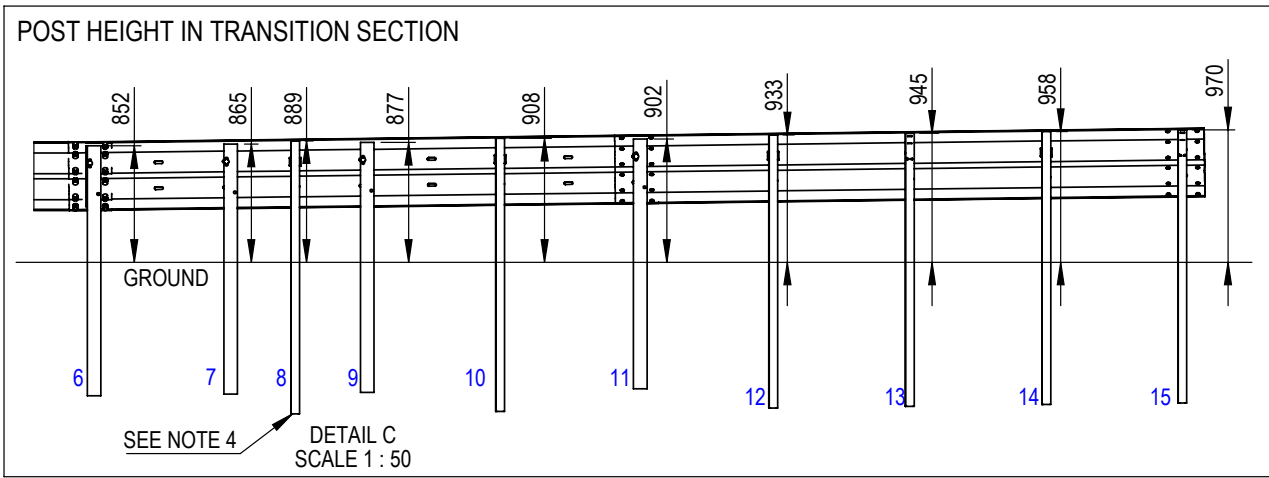
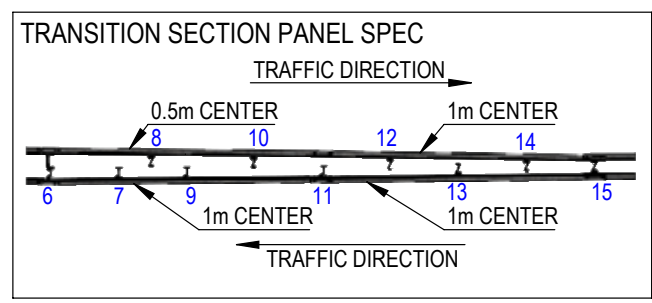

| REV. | DATE | DESCRIPTION | DRAWN | CHECKED | APPROVED |
|------|------------|--|-------|---------|----------|
| 1 | 13/02/2024 | POST RAIL HEIGHT DESCRIPTION AND POST NO. IDENTIFIER | KZ | LB | KZ |

| DRAWING NUMBER | REFERENCE DRAWINGS |
|----------------|--------------------|
| | |

| NAME | DATE |
|-------------|---------------|
| DRAWN KZ | 06-02-2024 |
| CHECKED MW | 06-02-2024 |
| APPROVED KZ | 06-02-2024 |
| SCALE 1:90 | SHEET: 1 of 3 |
| ISSUE FOR | |

INGAL CIVIL PRODUCTS
A Valmont Group COMPANY

| | |
|---------|--|
| PROJECT | INGAL RBT TO MEDIAN EZY-GUARD HC - 14M |
|---------|--|

| | |
|-------------------------------|-------------|
| INGAL CIVIL PRODUCTS PART No. | 10010728 |
| DRAWING No. | RBT-STD-010 |
| Rev. | 1 |

FOLDER: F:\ENGINEERING4 - DRAWINGS IN PROGRESS_SOLIDWORKS MODEL IN PROGRESS\INGAL RBT\CURRENT\MODEL

| ID | DESCRIPTION | PART NO. | QTY. |
|----|--|----------|------|
| 1 | THRIEBEAM TERMINAL CONNECTOR | 10001174 | 2 |
| 2 | THRIEBEAM (3.5) 4000mm NLL BRIDGE APPROACH | 10000854 | 2 |
| 3 | W6 x 9 RBT POST - 1830mm | 10010287 | 9 |
| 4 | M16 OVERSIZE NUT | 10001239 | 106 |
| 5 | M16 X 50mm POST BOLT GRADE 4.6 | 10001233 | 8 |
| 6 | 200mm x 110mm U BLOCK | 10010579 | 2 |
| 7 | M16 x 250mm TERMINAL BOLT | 10009787 | 2 |
| 8 | M16 x 40mm H/T HEX HEAD BOLT/NUT & WASHER GALV | 10004513 | 2 |
| 9 | 20NB HEAVY GALV PIPE 185mm LONG | 10010580 | 2 |
| 10 | CLAWBOLT EAW-GD M20 x 200mm | 10010398 | 10 |
| 11 | HD MEDIAN Z POST 2000mm | 10008505 | 1 |
| 12 | Ezy-Guard HD Carriage | 10004116 | 7 |
| 13 | M16 x 30mm EZY-GUARD SMART POST BOLT | 10001832 | 7 |
| 14 | THRIEBEAM (2.7) 4000mm NLL 1000mm CENTRES | 10000849 | 3 |
| 15 | HD Z POST 2000mm | 10005540 | 5 |
| 16 | M16 X 32 SPLICE BOLT GRADE 8.8 | 10001248 | 96 |
| 17 | THRIEBEAM 4000mm NLL 2.7mm BMT - 500 CENTRES | 10002916 | 1 |

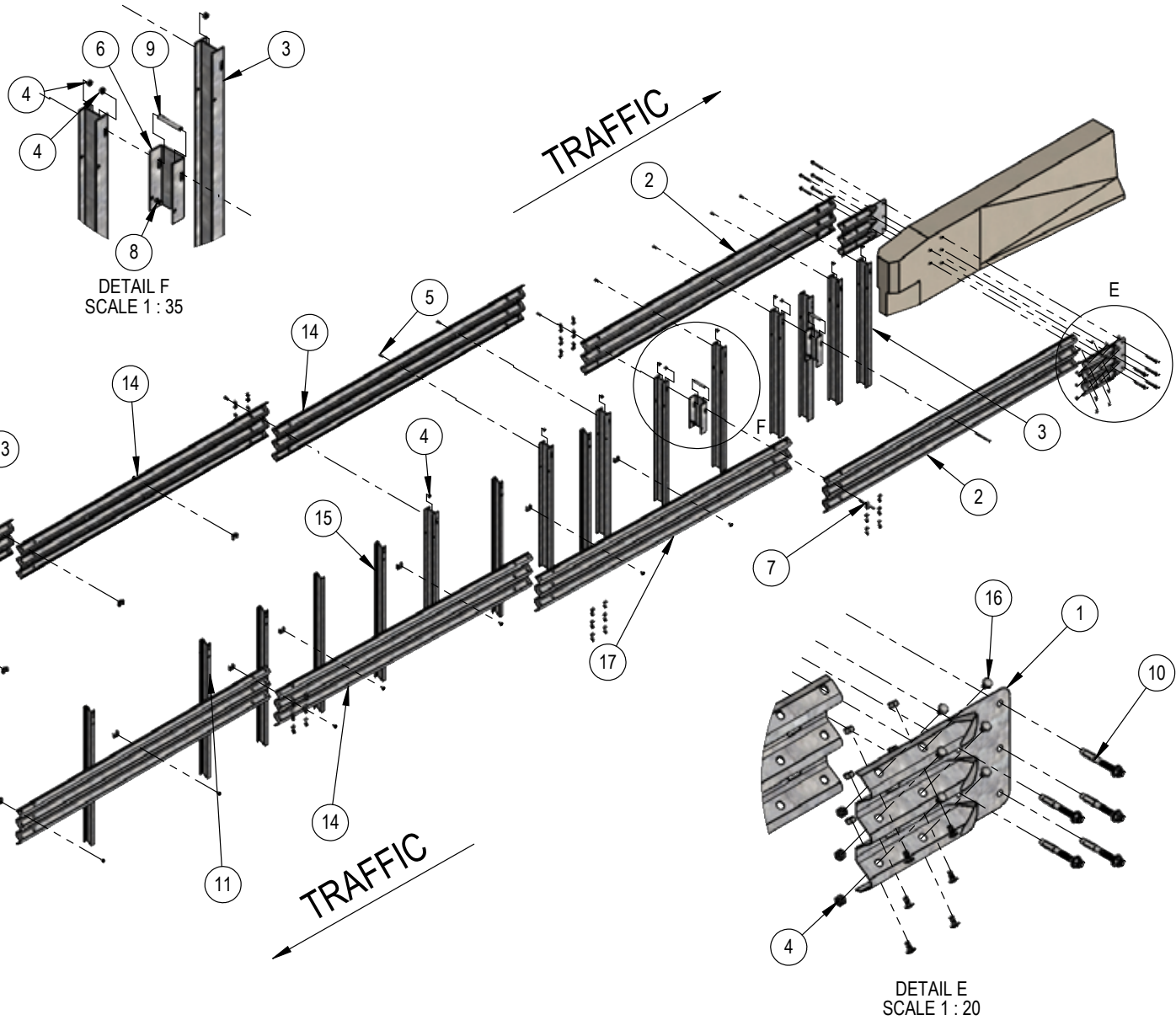

| REVISIONS | REFERENCES | | NAME | DATE |  <small>DRAWING AND CONTENTS ARE COPYRIGHT TO INGAL CIVIL PRODUCTS AND CAN ONLY BE USED WITH PRIOR WRITTEN CONSENT FROM INGAL CIVIL PRODUCTS</small> | PROJECT | INGAL CIVIL PRODUCTS PART No. | |
|-----------|----------------|--------------------|-----------|------|--|--|-----------------------------------|----------|
| | | | DRAWN | KZ | | 06-02-2024 | | 10010728 |
| | | | CHECKED | MW | | 06-02-2024 | | |
| | | | APPROVED | KZ | | 06-02-2024 | | |
| | | | SCALE | 1:70 | | SHEET: 2 of 3 | | |
| | DRAWING NUMBER | REFERENCE DRAWINGS | ISSUE FOR | | <small>157-65 AIRDS ROAD MUNICHO, N.S.W 2566</small> <small>PH: +61 2 9627 3333 www.ingalcivil.com.au</small> | TITLE INGAL RBT TO MEDIAN EZY-GUARD HC - EXPLODED VIEW | DRAWING No. RBT-STD-011 | |
| | | | | | | | Rev. 0 | |

FOLDER: F:\ENGINEERING4 - DRAWINGS IN PROGRESS\ SOLIDWORKS MODEL IN PROGRESS\INGAL RBT\CURRENT\TYL_MODEL1



INGAL
CIVIL PRODUCTS
A valmont  COMPANY

For more information

contact us on the web

www.ingalcivil.com.au

Head Office: Sydney

57-65 Airds Road, Minto, NSW 2566

Ph: +61 2 9827 3333

Fax: +61 2 9827 3300

Local call (within Australia):

1300 446 425

Email: sales@ingalcivil.com.au

Our Locations:

• Adelaide/NT • Brisbane

• Melbourne • Newcastle

• Perth • Sydney • Wagga

• Auckland • Christchurch