



TREND[®] MEDIAN

Median Attenuating TREND[®] Terminal

Product Manual



Release 10/23

MASH TL3 COMPLIANT

www.ingalcivil.com.au

Introduction

The TREND® MEDIAN is a tangent, double-sided, re-directive/gating and energy absorbing attenuator/end terminal, for use with various longitudinal highway barriers, in either unidirectional or bidirectional traffic applications, to include roadside, shoulder, median and gore installations.

The TREND® MEDIAN has been tested to the American Association of State and Highway Transportation Officials ("AASHTO") Manual for Assessing Safety Hardware, 2nd Edition-2016, 2020 Errata ("MASH") criteria, as a Test Level 3 ("TL-3") device.

MASH TL3 COMPLIANT



WARNING: The local highway agency, distributors, owners, and contractors are RESPONSIBLE for the assembly, maintenance, and repair of the TREND® MEDIAN . Failure to fulfill these RESPONSIBILITIES with respect to the assembly, maintenance, and repair of the TREND® MEDIAN could result in serious injury or death.

IMPORTANT: These instructions are for standard assembly specified by the appropriate highway agency. In the event the specified system assembly, maintenance, or repair would require a deviation from standard assembly parameters, contact an Ingal Civil Products representative.

This manual must be available to the worker overseeing and/or assembling the product at all times. For additional copies, contact Ingal Civil Products at 1300 446 425 or visit <https://www.ingalcivil.com.au/products/road-safety-barriers/MASH-end-terminals/> to confirm the latest revision.

The instructions, illustrations, and specifications are based on the latest TREND® MEDIAN information available to Ingal Civil Products at publication. We reserve the right to make changes at any time. Please visit <https://www.ingalcivil.com.au/products/road-safety-barriers/MASH-end-terminals/> to confirm the latest revision.

Customer Service Contacts

Ingal Civil Products is committed to the highest level of customer service. Feedback regarding the TREND® MEDIAN , its assembly procedures, supporting documentation, and performance is always welcome. Additional information can be obtained from the contact information below:

Ingal Civil Products

Telephone: 1300 446 425
 E-mail: sales@ingalcivil.com.au
 Internet: www.ingalcivil.com.au

TREND® MEDIAN Acronyms And Abbreviations

AASHTO	American Association of State Highway and Transportation Officials
CFR	Code of Federal Regulation
CR	Cable Release (Ref: CRP®)
FHWA	Federal Highway Administration
Nm	Newton-Meters
MASH	Manual for Assessing Safety Hardware 2ND Edition, published in 2016, (Errata in 2020)
MUTCD	Manual on Uniform Traffic Control Devices
NCHRP	National Cooperative Highway Research Program
NHS	National Highway System
OSHA	Occupational Safety & Health Administration
PPE	Personal Protective Equipment
SYTP®	Steel Yielding Terminal Post®
TL-3	Test Level-3

Limitations and Warnings

TREND® MEDIAN was tested to MASH-2nd Edition (with 2020 Errata) TL-3 criteria and may be used in Test Level 1, Test Level 2, and Test Level 3 applications – when installed at the full Test Level 3 system length of 10.477m. These tests typically evaluate product performance defined by MASH involving a range of vehicles on roadways, approximately 1,100kg and full size pickup trucks approximately 2,270 kg at 100 km/h.

The TREND® MEDIAN is tested pursuant to the test matrix criteria of MASH as designated by AASHTO and FHWA. The FHWA/AASHTO tests are not intended to represent the performance of systems when impacted by every vehicle type or in every impact condition existing on the roadway. Every departure from the roadway is a unique event.

Ingal Civil Products expressly disclaims any warranty or liability for injury or damage to persons or property resulting from any impact, collision or harmful contact with its products, other vehicles, or nearby hazards or objects by any vehicle, object or person, whether or not the products were assembled in consultation with Ingal Civil Products or by third parties.

The TREND® MEDIAN is intended to be assembled, delineated, and maintained within the state/specifying agency and federal guidelines. It is important for the state/specifying agency to select the most appropriate product configuration for site specifications.

The state/specifying agency's careful evaluation of the site layout, vehicle population type and speed, traffic direction, and visibility are some of the elements that require evaluation in the selection of a highway product. For example, kerbs could cause an untested effect on an impacting vehicle.

After an impact with the system, all debris must be removed from the area immediately in compliance with the most applicable state/specifying agency policy. The specified TREND® MEDIAN must be evaluated and restored to its original specified condition or replaced as the state/specifying agency determines/requires, as soon as possible. Product selection, approval, proper installation, and maintenance of any highway product is the sole responsibility of the state/specifying agency.

WARNING: Under NO circumstances shall the rail within the TREND® MEDIAN be curved between Post 1 and Post 6.

WARNING: Do NOT modify the TREND® MEDIAN in any way.

Safety Alert Symbols appear throughout this manual and indicate Danger, Warning, Caution or Important statements. Failure to read and follow these warnings could result in serious injury or death in the event of a vehicle impact with the system.



WARNING: Do not assemble, maintain, or repair the TREND® MEDIAN until you have read this manual thoroughly and completely understand it. Ensure that all Danger, Warning, Caution, and Important statements within the manual are completely followed. Please call Ingal Civil Products at 1300 446 425 if you have any questions about instructions in this manual.

WARNING: Safety measures incorporating appropriate traffic control devices and personal protective equipment ("PPE") specified by the state/specifying agency must be used to protect all personnel while at the assembly, maintenance, or repair site. Work gloves, apron, eye protection, safety-toe shoes, and back protection shall be used.

WARNING: Ensure the assembly site meets all appropriate Manual on Uniform Traffic Control Devices ("MUTCD") and the state/specifying agency standards.

WARNING: Use only Ingal Civil Products parts that are specified by Ingal Civil Products for use with the TREND® MEDIAN for assembling, maintaining, or repairing the TREND® MEDIAN. Do not utilize or otherwise commingle parts from other systems even if those systems are other Ingal Civil Products or Systems. Such configurations have not been tested, nor have they been approved for use. Assembly, maintenance or repairs using unspecified parts or accessories is strictly prohibited. Failure to follow this warning could result in serious injury or death in the event of a vehicle impact with such an UNACCEPTED system.

IMPORTANT: Ingal Civil Products makes no recommendation whether use or reuse of any part of the TREND® MEDIAN is appropriate or acceptable after system impact. It is the responsibility of the state/specifying agency and its engineers to make that determination.

IMPORTANT: It is the responsibility of owner, state/specifying agency, or specifier to inspect the TREND® MEDIAN after assembly is complete to ensure the instructions provided in this manual have been strictly followed.

1.0 Overview

The TREND® MEDIAN has a system length of 10.477m long and is a tangent, 787mm [+25/-0mm] high, double-sided, re-directive/gating and energy absorbing attenuator/end terminal available for use with various longitudinal highway barriers, in either unidirectional or bidirectional traffic applications.

The TREND® MEDIAN consists of TREND® MEDIAN 3.4mm and 2.7mm BMT slotted guardrail, TREND® MEDIAN 2.7mm BMT transition guardrail with an integrated fin and TREND® MEDIAN 2.7mm BMT slotted guardrail with an integrated fin, TREND® MEDIAN 3.4mm BMT head rail, TREND® MEDIAN impact head, TREND® MEDIAN CR top and bottom posts, TREND® MEDIAN SYTP® with soil plate, TREND® MEDIAN system line post with soil plate, TREND® MEDIAN angle strut, TREND® MEDIAN cable assembly, TREND® MEDIAN spacers, composite offset blocks and various other required hardware accessories.

When connecting the TREND® MEDIAN to Ezy-Guard 4 or Ezy-Guard HC – refer to the drawings to the end of this manual for appropriate transition details.

GAUGE CONVERSIONS	
10 Gauge	3.43mm
12 Gauge	2.67mm

Specifications	
System Weight	692 kg
System Length	10.48 m
System Width (at impact head)	737 mm
System Height (except impact head)	787 mm, +25 mm/-0 mm
Beginning Length-of-Need ("BLON") established during MASH Test 3-35 at Post #3,	3.81 m from Post 1

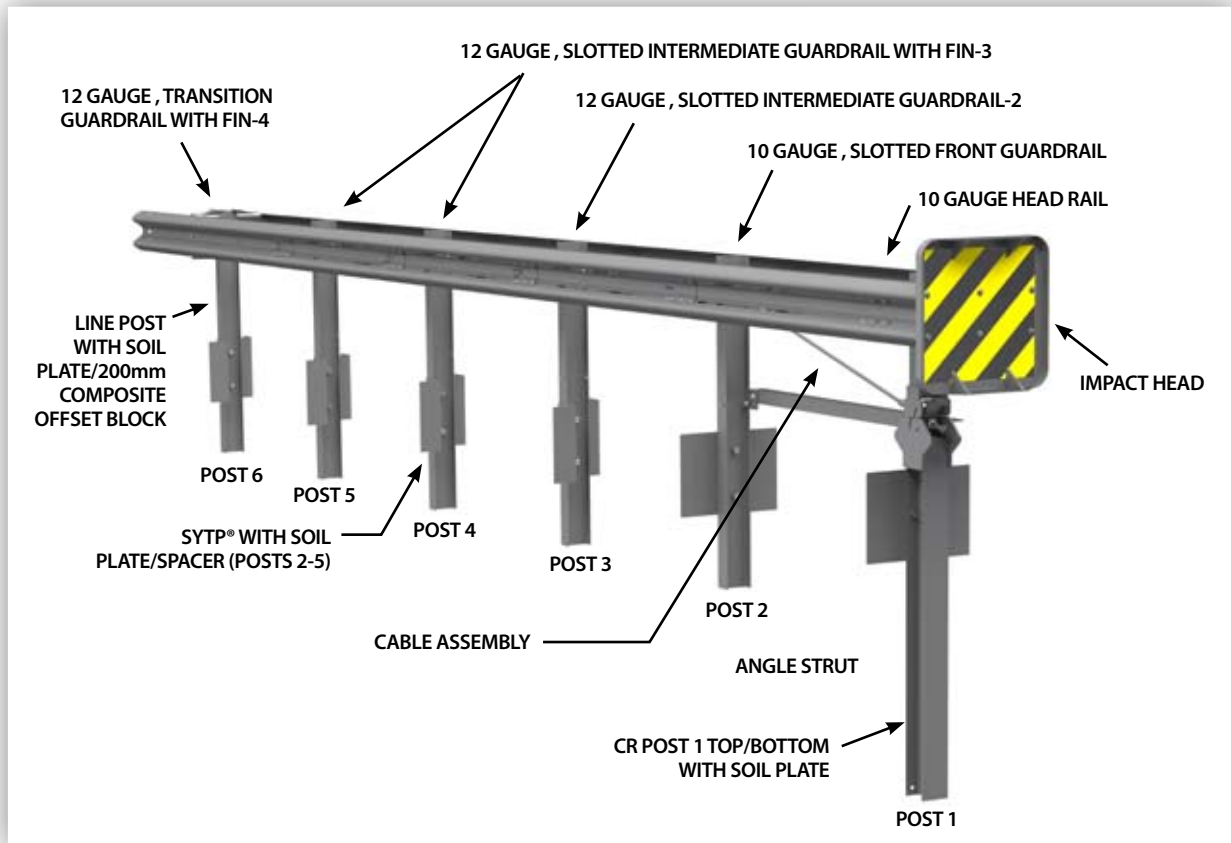

TREND® MEDIAN Reference Drawing: SS-6288

2.0 Recommended Tools

Documentation

- Manufacturer's TREND® MEDIAN Product Description Assembly Manual (Current Version).
- TREND® MEDIAN Drawing(s) SS-6288 (Current Version).

Personal protective equipment (PPE)

- Eye Protection
- Work Gloves
- Safety-Toe Shoes
- Back Protection
- Hard Hat
- Reflective Vest
- Apron

Miscellaneous

- Traffic Control Equipment and Plan per state/ specifying agency standards and the MUTCD.
- SAE Combination Wrench Set
- Socket Set & Socket Wrench
- Hammer
- Chalk Line
- Tape Measure
- Marking Paint and Pen
- Straight Edge
- Level
- Plumb Line
- Post Pounder (commonly used for driving posts)
- Auger
- Soil Tamper
- 5/8" Alignment Tool (Drift Pin), used to help align panels
- Locking Pliers and/or Pipe Wrench
- Calibrated Torque Wrench, capable of measuring 88 Nm.

Note: The provided list of tools is a general recommendation and should not be considered an extensive list. Depending on specific site conditions and the complexity of the assembly, the required tools may vary. Decisions as to what tools are needed to perform the job are entirely the responsibility of the state/specifying agency and the selected contractor performing the assembly of the system at the state/specifying agency's site.

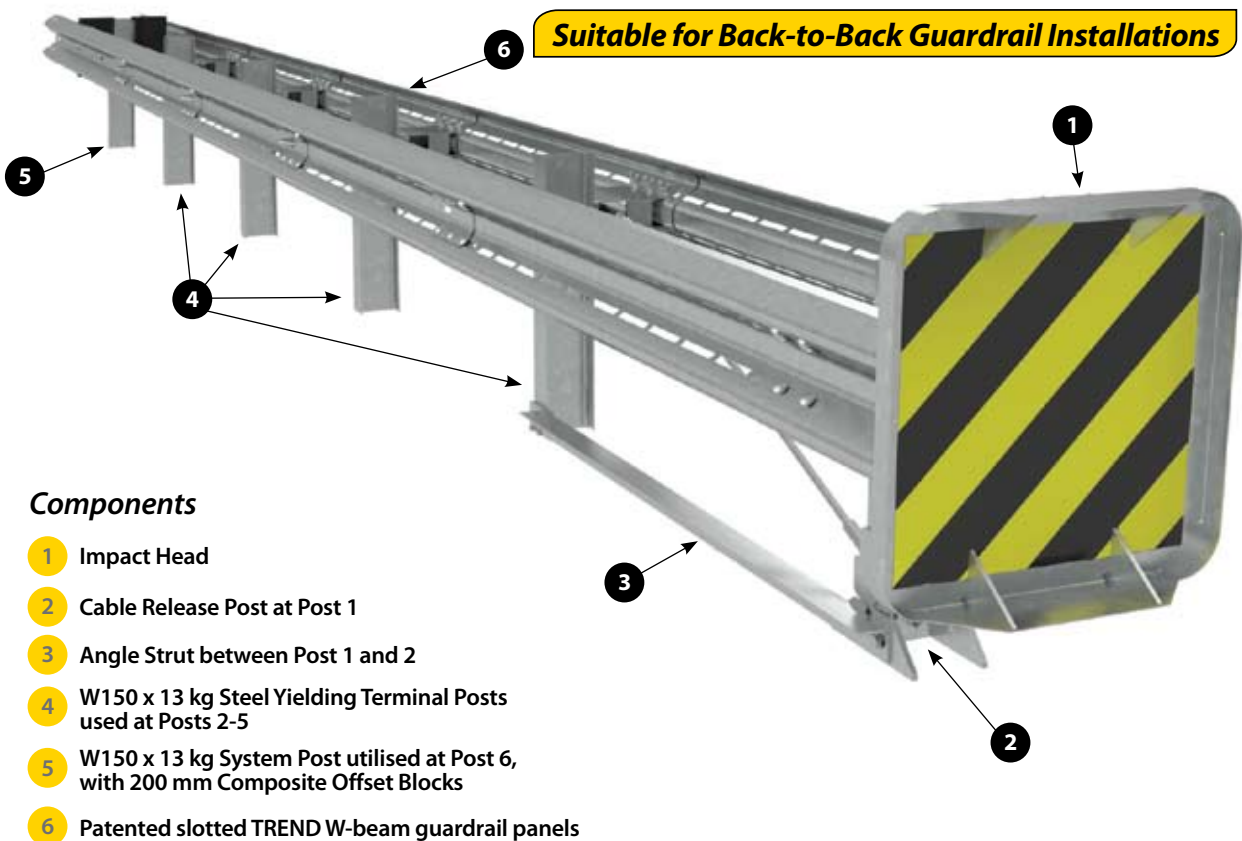

3.0 Site Preparation

The TREND[®] MEDIAN has a system length of 10.477m, long and is a tangent, 787mm [+25 mm, -0 mm] high, double-sided, re-directive/gating and energy absorbing attenuator/end terminal available for use with various longitudinal highway barriers, in either unidirectional or bidirectional traffic applications.

It may be specified for use by the state/specifying agency in conjunction with strong post W-beam guardrail systems on the NHS or other roadway. The decision to specify the TREND[®] MEDIAN for a particular project is the responsibility of the state/specifying agency design engineer who must ensure that the most appropriate end treatment has been selected for the specific site conditions.

The TREND[®] MEDIAN is designed to be attached directly to double sided W-beam guardrail systems that have been accepted under MASH or NCHRP Report 350 crash test criteria.



IMPORTANT: Under NO circumstances shall the rail within the TREND[®] MEDIAN be curved, between Post 1 and Post 6. Ensure all TREND[®] MEDIAN post spacings are 1.905m on center.



IMPORTANT: When used with rigid barriers, (i.e. concrete barrier, wall or bridge pier) a semi to rigid barrier transition will be required (see state/specifying agency standards).



IMPORTANT: Ensure that the TREND[®] MEDIAN application conforms to the AASHTO Roadside Design Guide, current edition to include appropriate grading details.



IMPORTANT: Ingal Civil Products does not direct grading. Proper site grading must be accomplished before assembly of the TREND[®] MEDIAN in accordance with local guidelines OR the AASHTO Roadside Design Guide (see Appendix A and B), whichever is more stringent. Failure to follow this warning could result in serious injury or death in the event of a vehicle impact with the system.



IMPORTANT: The Beginning Length of Need (“BLON”) for the TREND[®] MEDIAN was established during MASH Test 3-35 at Post 3, which is 3.810m from Post 1.



IMPORTANT: Only 200 mm composite offset blocks can be used at Post 6 and only the supplied special TREND[®] MEDIAN spacers/double spacers at all other post locations.



TREND MEDIAN was tested to MASH-2nd Edition (with 2020 Errata) Test Level 3 criteria and may be used in Test Level 1, Test Level 2, and Test Level 3 applications – when installed at the full Test Level 3 system length of 10.477m.



4.0 Post Placement

The TREND[®] MEDIAN posts are inserted into the soil using an auger or post pounding equipment for placement. If an auger is used, ensure diameter is large enough to allow for proper compaction of state/specifying agency approved fill material. All TREND[®] MEDIAN posts must be assembled within established standard construction tolerances, including being plumb. Compaction for all posts must be within the state/specifying agency guidelines.



DANGER: It is the responsibility of the installer to ensure all above & below ground utilities as well as drainage structures are located, marked, and identified prior to using an auger or post pounding tool in accordance with state/ specifying agency guidelines. Failure to follow this warning could result in serious injury or death.

Rigid Pavement and Rock

If rigid pavement (e.g. concrete or asphalt) of any thickness is encountered within the system, ensure a proper "leave-out" area (the specified size of open space as defined in the AASHTO Roadside Design Guide) and/or per the state/ specifying agency is provided around the posts and filled with the state/ specifying agency approved backfill material.

If solid rock is encountered at post locations 3-6, refer to the state/specifying agency guidelines and/or the AASHTO Roadside Design Guide for requirements for embedment depth into the rock and size of the hole. If solid rock is encountered at post locations 1-2, auger a hole in the rock large enough for full post embedment and proper compaction of approved fill material.

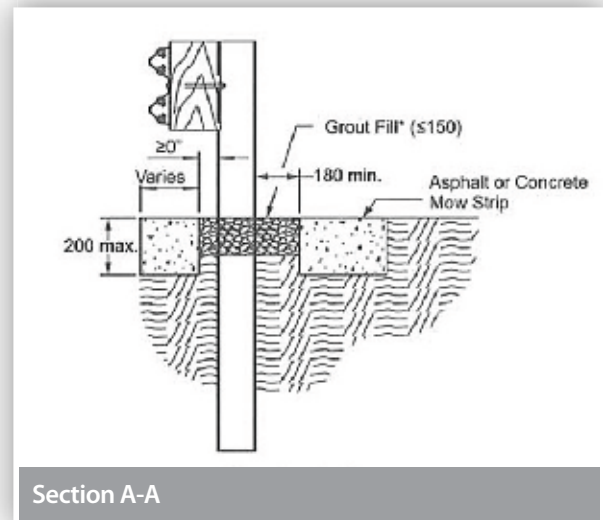
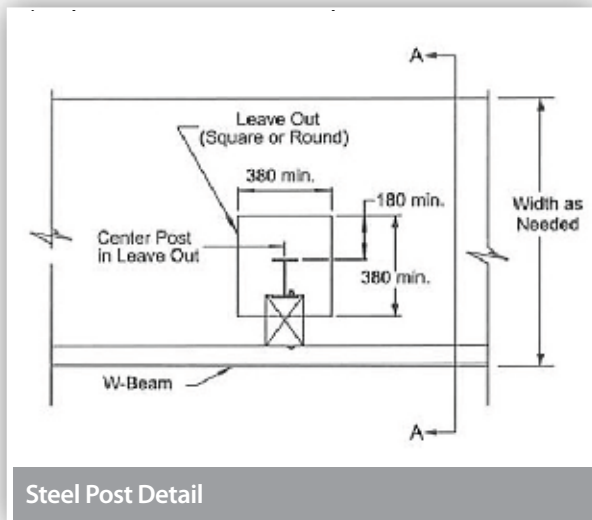

5.0 Inspect Shipment

Carefully unpack and inspect all components for damage. Check the received parts against the packing list supplied with the system. If any parts are damaged, missing, or unspecified; do not attempt to assemble the system and contact Ingal Civil Products immediately (p. 4).



WARNING: Use only Ingal Civil Products parts that are specified by Ingal Civil Products for use with the TREND® MEDIAN for assembling, maintaining, or repairing the TREND® MEDIAN. Do not utilize or otherwise commingle parts from other systems even if those systems are other Ingal Civil Products or Systems.

ID	TREND® MEDIAN COMPONENTS/HARDWARE	INGAL PN	QUANTITY
A	TREND® MEDIAN Impact Head	10010453	1
B	TREND® MEDIAN 2.7mm BMT Transition Guardrail With Fin-4, 2.858m	10010449	2
C	TREND® MEDIAN 2.7mm BMT, Slotted Intermediate Guardrail With Fin-3, 1.905m	10010450	4
D	TREND® MEDIAN 2.7mm BMT, Slotted Intermediate Guardrail-2, 1.905m	10010442	2
E	TREND® MEDIAN 3.4mm BMT, Slotted Front Guardrail-1, 1.905 m	10010454	2
F	TREND® MEDIAN 3.4mm BMT Head Rail, 552mm	10010452	2
G	TREND® MEDIAN Single Spacer	10010447	6
H	TREND® MEDIAN Double Spacer	10010446	2
I	TREND® MEDIAN Head Tube	10010443	1
J	TREND® MEDIAN Backing Plate	10010451	8
K	TREND® MEDIAN CR Post 1 Top	10010448	1
L	TREND® MEDIAN CR Post 1 Bottom – used with soil plate	10010444	1
M	TREND® MEDIAN SYTP® 1.83m – used with soil plate	10010440	4
N	TREND® MEDIAN System Line Post 1.83m – used with soil plate	10010439	1
O	TREND® MEDIAN Angle Strut	10010445	1
P	TREND® MEDIAN Cable Assembly 19 mm x 2.260m	10010457	1
Q	Cable Anchor Bracket Angle	10010456	1
R	TREND® MEDIAN Strut Adapter Plate	10010455	1
S	M8 x 45mm Hex Set Screw Grade 8.8 Galv	10010125	2
T	Hex Bolt M16 x 45 G8.8 HDG AS1252	10009525	6
U	M16 x 32 Splice Bolt G8.8	10001248	16
V	Hex Bolt M16 x 50 G8.8 HDG AS1252	10004062	6
W*	M16 x 50 Post Bolt G8.8 HDG AS1252	10004030	62
Y	M8 Hex Nut CL8 HDG AS1112.1	10009443	2
Z*	M16 Nut CL8 HDG AS1252	10001254	66
AA	M16 Round Washer AS1237.1	10009527	8
BB	M16 Oversize Nut CL8	10001239	36
CC	25mm Flat Washer	10002161	10
DD	25mm Hex Nut	10007549	2
EE	M16 Flat Washer OD 35mm Thickness 6mm	10007653	62
FF	M12 x 45 N/B/W 8.8 CL8 HDG	10001727	4
GG	M12 Round Washer HDG	10001727	8
HH	M12 Hex Nut CL8 HDG	10001727	4
JJ	M8 Flat Washer Galv	10001305	2
KK	MASH King Block	10001397	2
MM	TREND® MEDIAN Soil PL, 6 mm x 457 mm x 610 mm for Posts 1-2	10010441	2
NN	TREND® MEDIAN Soil Plate W-Shaped (Multi-Directional) for Posts 3-6	10010438	4
OO	M16 x 90 Hex Bolt G8.8	10010126	10
TT	M16 x 250mm Terminal Bolt	10009787	2

ID	Optional Delineation Available From Ingal Civil Products	PN	QUANTITY
YY	625 mm x 625 mm Yellow/Black Reflector (Median/Roadside)	105379B	1
ZZ	625 mm x 625 mm Yellow/Black Reflector (Gore)	105380B	1

- Fastener combinations at 62 locations of “W”, M16 x 50 Post Bolt and “Z”, M16 Nut DH require the Nuts to be torqued to 88 Newton-Meters “Nm”, [+/- 4 Nm]. See Step 16 for the 62 locations.

GAUGE CONVERSIONS	
10 Gauge	3.43mm
12 Gauge	2.67mm

6.0 TREND® MEDIAN Components/Hardware

Below is a pictorial depiction of the components/hardware for TREND® MEDIAN . Please see the Ingal Civil Products drawings and page 10 of this manual for specific lists of components/hardware and quantities required for TREND® MEDIAN selected to be assembled.

Note: The following components/hardware are not shown to scale.

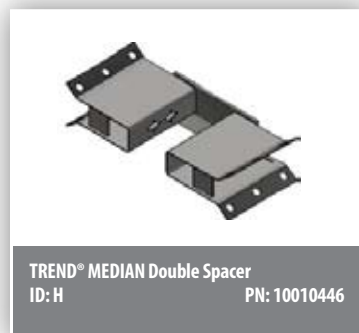



TREND® MEDIAN Backing Plate
ID: J PN: 10010451



TREND® MEDIAN CR Post 1 Top
ID: K PN: 10010448



TREND® MEDIAN CR Post 1 Bottom
ID: L PN: 10010444

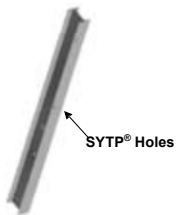

TREND® MEDIAN SYTP® 1.83m
ID: M PN: 10010440



TREND® MEDIAN Line Post 1.83m
ID: N PN: 10010439



TREND® MEDIAN Angle Strut
ID: O PN: 10010445



TREND® MEDIAN Cable Assembly 19 mm x 2.26m
ID: P PN: 10010457

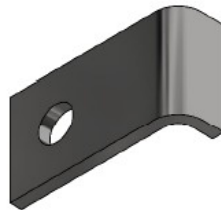

Cable Anchor Bracket Angle
ID: Q PN: 10010456



TREND® MEDIAN Strut Adapter Plate
ID: R PN: 10010455



M8 x 45mm Hex Set Screw Grade 8.8 Galv
ID: S PN: 10010125



Hex Bolt M16 x 45 G8.8 HDG AS1252
ID: T PN: 10009525



M16 x 32 Splice Bolt G8.8
ID: U PN: 10001248



Hex Bolt M16 x 50 G8.8 HDG AS1252
ID: V PN: 10004062



M16 x 50 Post Bolt G8.8 HDG AS1252
ID: W PN: 10004030



M8 Hex Nut CL8 HDG AS1112.1
ID: Y PN: 10009443





7.0 ASSEMBLY STEPS



To ensure an accurate assembly of the TREND® MEDIAN Terminal, it is recommended that steps be completed in order. **ALL STEPS MUST BE COMPLETED.**



Below ground portions in some assembly steps are not shown for clarity.



See Step 16 for bolt/nuts combinations that must be torqued to 88 Nm [\pm 4 Nm].



After the system is fully assembled, for Steps 5A and 5B, tighten the double/single spacers to a snug position with a minimum of two (2) bolt threads protruding beyond the nut for all hardware that was assembled loosely, ensuring bolt is seated for these steps.

TREND® MEDIAN GUARDRAIL IDENTIFICATION/ORIENTATION

Note: The rail panel splice holes and fin are always located upstream (towards the impact head)



E

TREND® MEDIAN 3.4mm BMT, Slotted Front Guardrail Without Fin-1, 1.905m PN 628347G



D

TREND® MEDIAN 2.7mm BMT, Slotted Intermediate Guardrail Without Fin-2, 1.905m PN 628274G



C

TREND® MEDIAN 2.7mm BMT, Slotted Intermediate Guardrail WITH Fin-3, 1.905m PN 628337A



B

TREND® MEDIAN 2.7mm BMT, Transition Guardrail WITH Fin-4, 2.858m PN 628289A



8.0 INSTALLATION PROCEDURE

STEP 1
TREND[®] MEDIAN Post Layout (Posts 1-6)

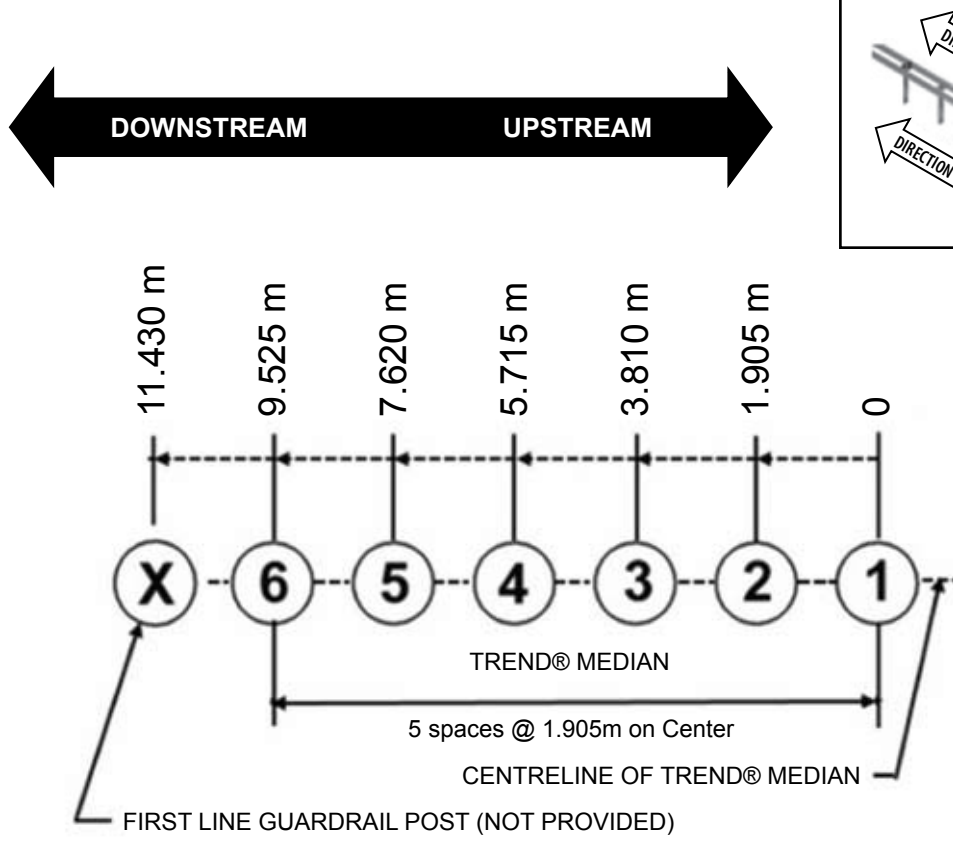

PARTS

INSTRUCTIONS

Reference: TR-MED-001

1. Layout the post locations as shown above.
2. Layout and placement of the posts are critical to the assembly of the TREND[®] MEDIAN .
3. All TREND[®] MEDIAN posts are spaced at 1.905m on center and installed reasonably plumb.
4. TREND[®] MEDIAN Posts 2-6 heights are 813mm [+25 mm, -0 mm] above finished grade.
5. The height of the TREND[®] MEDIAN CR Post 1 Bottom is 100 mm [+25mm, -0 mm] above finished grade.

WARNINGS



Ensure proper site grading in accordance with the state/specifying agency guidelines and/or the AASHTO Roadside Design Guide, whichever is more stringent. Failure to follow this warning could result in serious injury or death in the event of a vehicle impact with the system.

STEP 2A

TREND® MEDIAN CR Post 1 Bottom With Soil Plate Assembly

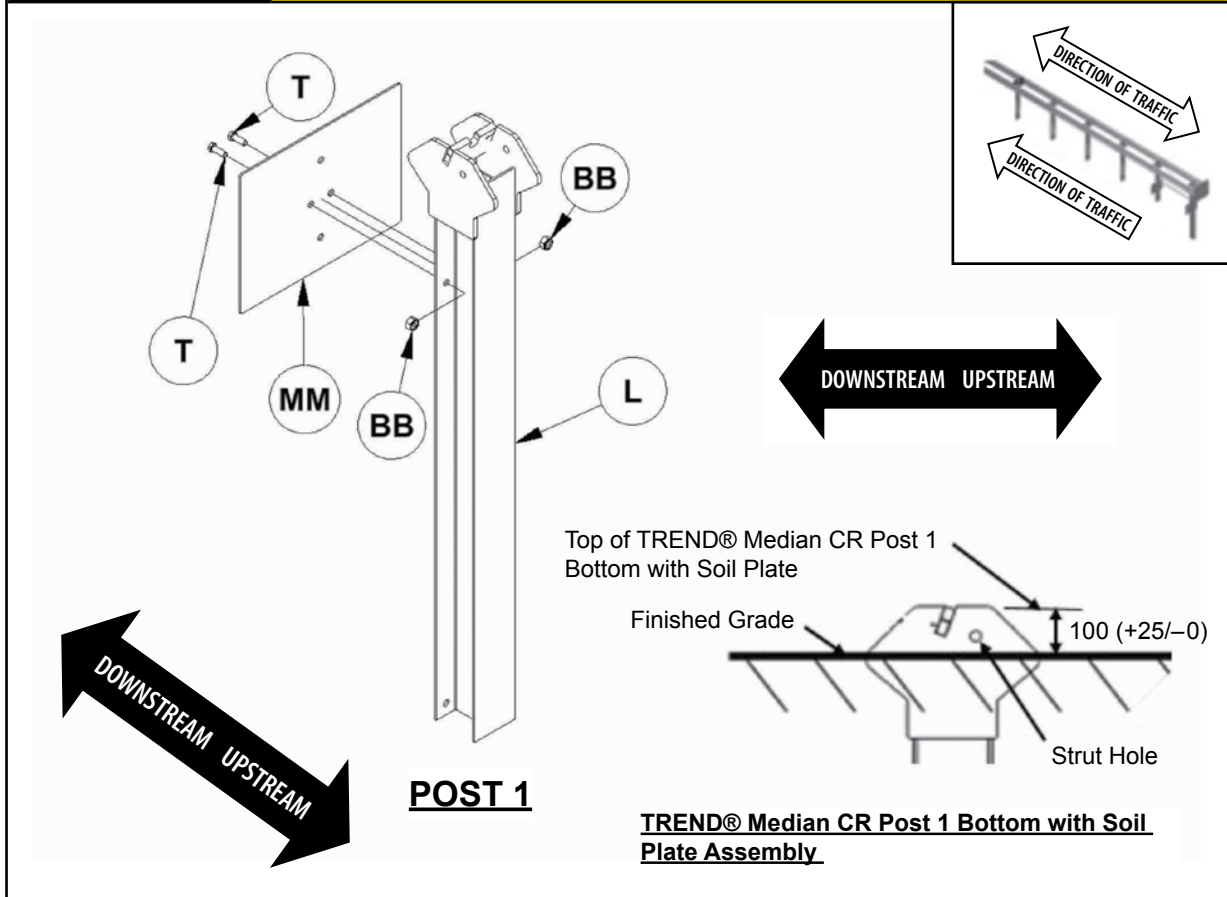

PARTS

L	TREND® MEDIAN CR Post 1 Bottom – used with soil plate	10010444	1 ea
T	Hex Bolt M16 x 45 G8.8 HDG AS1252	10009525	2 ea
BB	M16 Oversize Nut CL8	10001239	2 ea
MM	TREND® MEDIAN Soil PL, 6 mm x 457 mm x 610 mm for Posts 1-2	10010441	1 ea

INSTRUCTIONS

Reference: TR-MED-001

1. Assemble the TREND® MEDIAN Soil Plate (Part MM) to the **downstream** side of the 1.83m TREND® MEDIAN CR Post 1 Bottom (Part L) as shown above using specified hardware (Parts T, BB).
2. Tighten all threaded hardware to a snug position with a minimum of two (2) bolt threads protruding beyond the nut.
3. Assemble the 1.83m TREND® MEDIAN CR Post 1 Bottom With Soil Plate as shown above at location established in Step 1.
4. Ensure that the TREND® MEDIAN Strut Hole is assembled on the **upstream** side of the post.
5. Ensure the top of the TREND® MEDIAN CR Post 1 Bottom With Soil Plate is 100mm [+25mm, -0mm] above finished grade.

WARNINGS



Ensure the TREND® MEDIAN Soil Plate is on the **downstream** side of the CR Post 1 Bottom and Strut Hole is **upstream**. Ensure threaded hardware is tightened to a snug position with a minimum of two (2) bolt threads protruding beyond the nut.

Ensure the top of the TREND® MEDIAN CR Post 1 Bottom With Soil Plate is 100 mm [+25 mm, -0 mm] above finished grade. Failure to follow these warnings could result in serious injury or death in the event of a vehicle impact with the system.

STEP 2B

TREND® MEDIAN SYTP® With Soil Plate Assembly Post 2

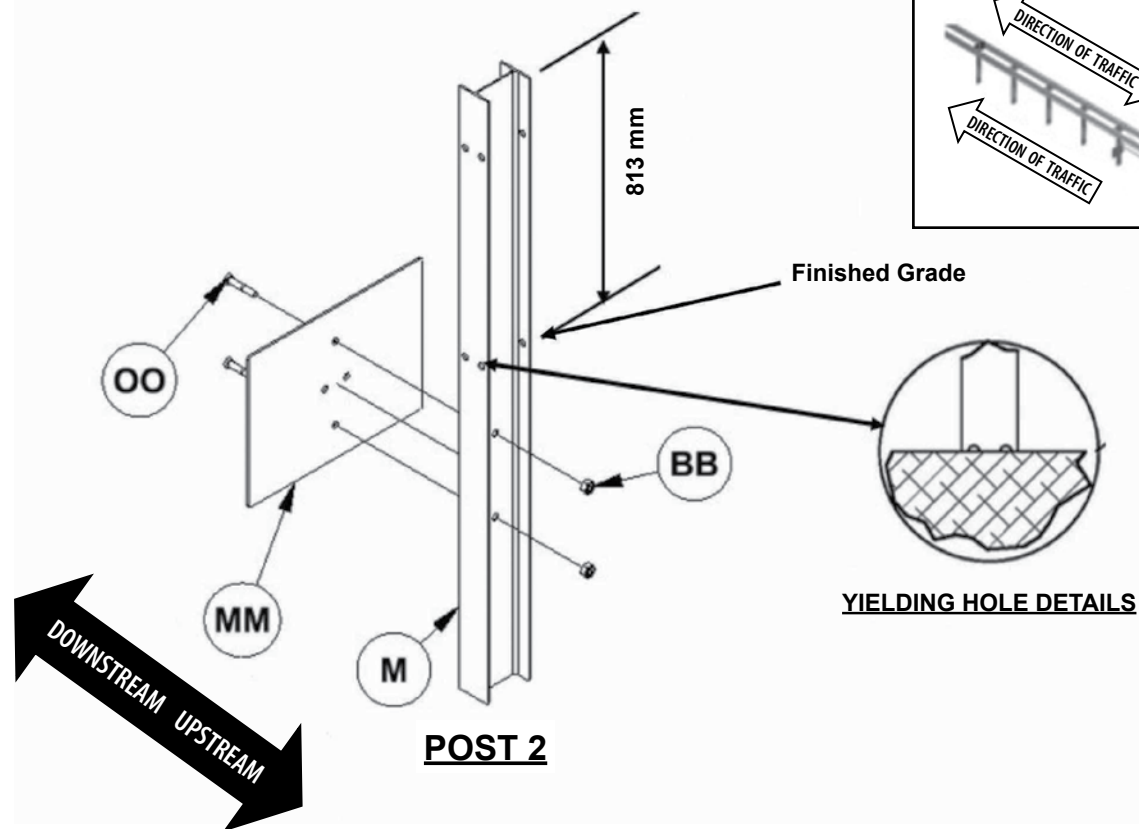

PARTS

M	TREND® MEDIAN SYTP® 1.83m – used with soil plate	10010440	1 ea
BB	M16 Oversize Nut CL8	10001239	2 ea
MM	TREND® MEDIAN Soil PL, 6 mm x 457 mm x 610 mm for Posts 1-2	10010441	1 ea
OO	M16 x 90 Hex Bolt G8.8	10010126	2 ea

INSTRUCTIONS

Reference: TR-MED-001

1. Assemble the TREND® MEDIAN Soil Plate (Part MM) to the downstream side of the 1.83m TREND® MEDIAN SYTP® (Part M) as shown above using specified hardware (Parts BB, OO).
2. Tighten all threaded hardware to a snug position with a minimum of two (2) bolt threads protruding beyond the nut.
3. Assemble the 1.83m TREND® MEDIAN SYTP® with Soil Plate on the downstream side of the post as shown above for Post 2 at location established in Step 1.
4. Ensure the center of the SYTP® Holes are approximately at finished grade [+25 mm, -0 mm].

WARNINGS



Ensure the TREND® MEDIAN Soil Plate is on the **downstream** side of the TREND® MEDIAN SYTP®. Ensure the center of the SYTP® Holes are approximately at finished grade [+25 mm, -0 mm]. Ensure the Post spacing is as established in Step 1. Ensure threaded hardware is tightened to a snug position with a minimum of two (2) bolt threads protruding beyond the nut. Failure to follow these warnings could result in serious injury or death in the event of a vehicle impact with the system.

STEP 2C

TREND® MEDIAN SYTP® With Soil Plate W-Shaped Assembly for Posts 3 to 5

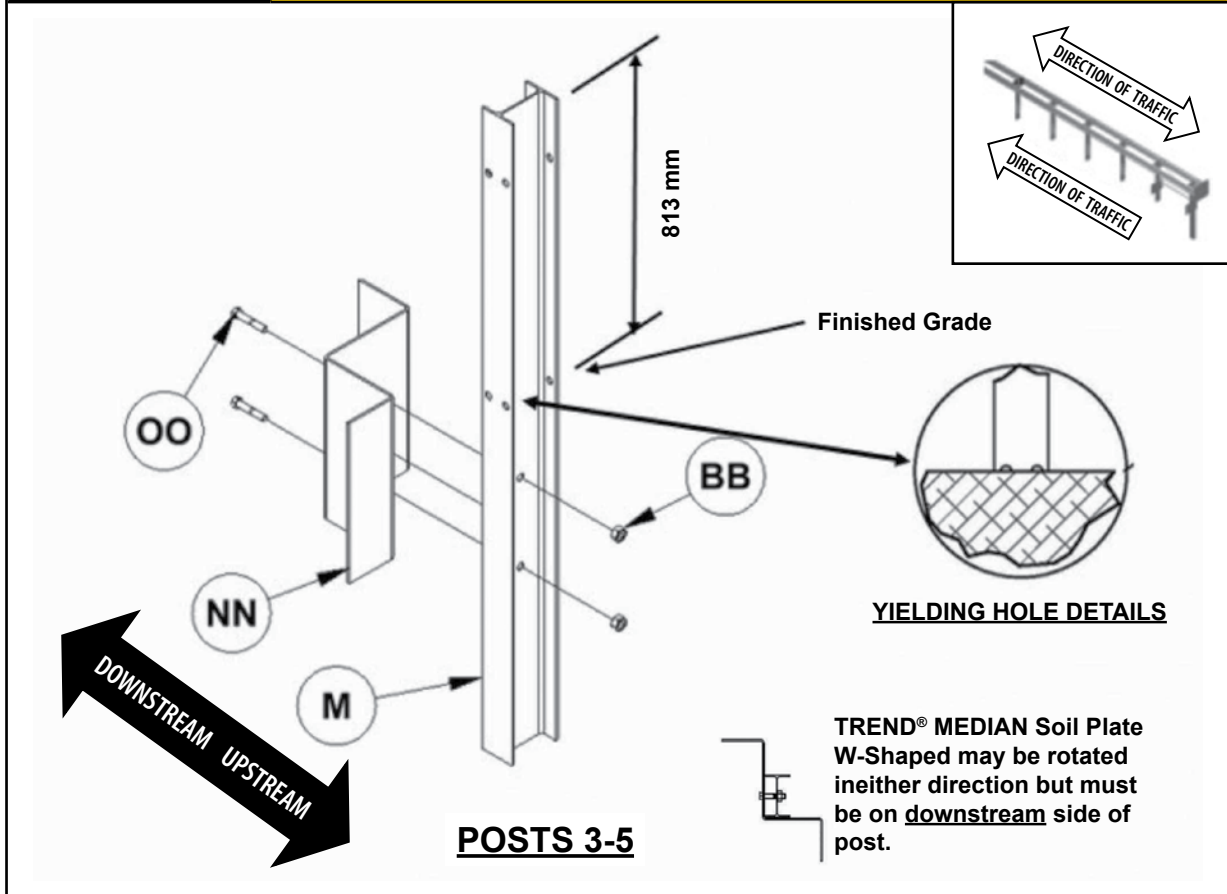

PARTS

M	TREND® MEDIAN SYTP® 1.83m – used with soil plate	10010440	3 ea
BB	M16 Oversize Nut CL8	10001239	6 ea
NN	TREND® MEDIAN Soil Plate W-Shaped (Multi-Directional) for Posts 3-6	10010438	3 ea
OO	M16 x 90 Hex Bolt G8.8	10010126	6 ea

INSTRUCTIONS

Reference: TR-MED-001

1. Assemble the TREND® MEDIAN Soil Plate W-Shaped (Part NN) to the **downstream** side of the 1.83m TREND® MEDIAN SYTP® (Part M) as shown above using specified hardware (Parts BB, OO).
2. Tighten all threaded hardware to a snug position with a minimum of two (2) bolt threads protruding beyond the nut.
3. Assemble the 1.83m TREND® MEDIAN SYTP® with Soil Plate W-Shaped on the **downstream** side of the post as shown above for Posts 3-5 at location established in Step 1.
4. Ensure the center of the SYTP® Holes are approximately at finished grade [+25 mm, -0 mm].

WARNINGS



- Ensure the TREND® MEDIAN Soil Plate W-Shaped is on the **downstream** side of TREND® MEDIAN SYTP® 3-5.
- Ensure the center of the SYTP® Holes are approximately at finished grade [+25 mm, -0 mm].
- Ensure the Post spacing is as established in Step 1.

Ensure threaded hardware is tightened to a snug position with a minimum of two (2) bolt threads protruding beyond the nut. Failure to follow these warnings could result in serious injury or death in the event of a vehicle impact with the system.

STEP 2D

TREND® MEDIAN Line Post With Soil Plate W-Shaped Assembly for Post 6

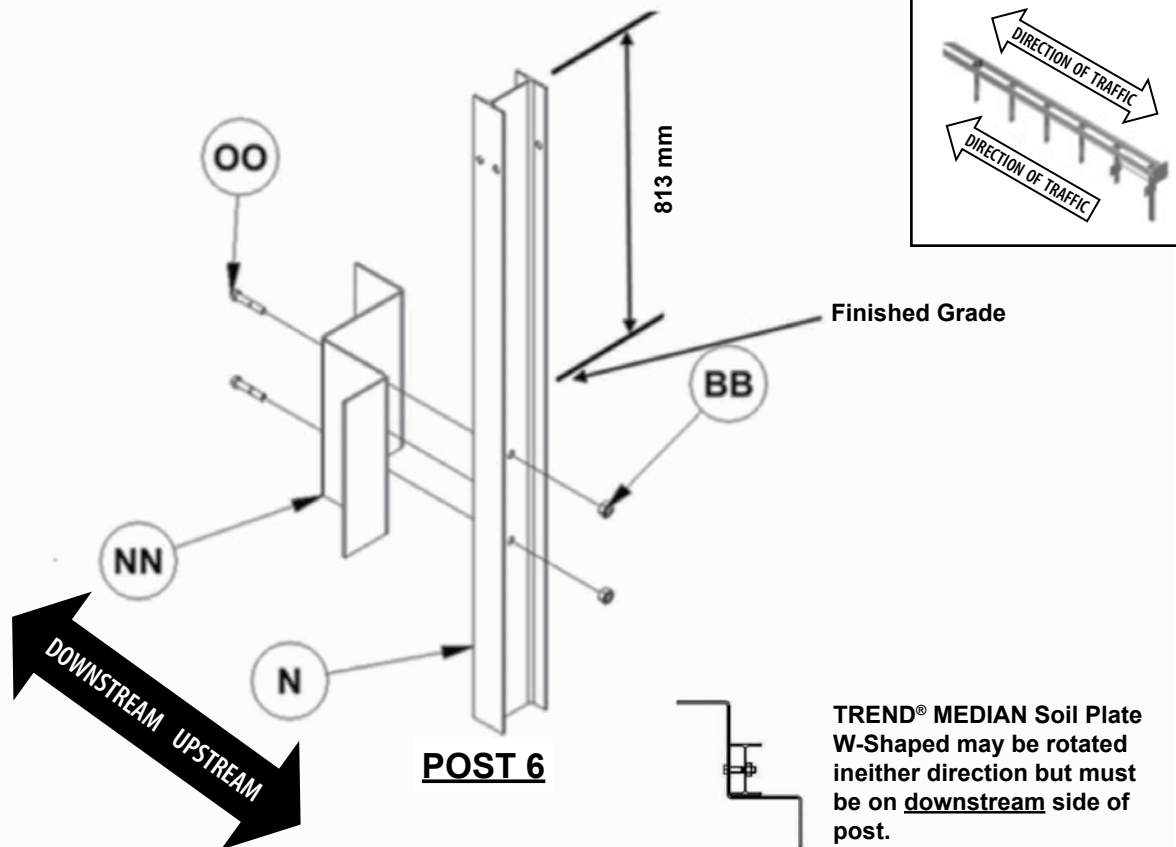

PARTS

N	TREND® MEDIAN System Line Post 1.83m – used with soil plate	10010439	1 ea
BB	M16 Oversize Nut CL8	10001239	2 ea
NN	TREND® MEDIAN Soil Plate W-Shaped (Multi-Directional) for Posts 3-6	10010438	1 ea
OO	M16 x 90 Hex Bolt G8.8	10010126	2 ea

INSTRUCTIONS

Reference: TR-MED-001

1. Assemble the TREND® MEDIAN Soil Plate W-Shape (Part NN) to the **downstream** side of the 1.83m TREND® MEDIAN System Line Post 6 (Part N) as shown above using specified hardware (Parts BB, OO).
2. Tighten all threaded hardware to a snug position with a minimum of two (2) bolt threads protruding beyond the nut.
3. Assemble the 1.83m TREND® MEDIAN System Line Post with Soil Plate W- Shaped on the **downstream** side of the post 813 mm [+25 mm, -0 mm] from finished grade as shown above for Post 6 at location established in Step 1.

WARNINGS



- Ensure the TREND® MEDIAN Soil Plate W-Shaped is on the **downstream** side of TREND® MEDIAN System Line Post 6.
- Ensure the Post spacing is as established in Step 1.
- Ensure threaded hardware is tightened to a snug position with a minimum of two (2) bolt threads protruding beyond the nut. Failure to follow these warnings could result in serious injury or death in the event of a vehicle impact with the system.

STEP 3

TREND® MEDIAN Angle Strut Assembly

Place the TREND® MEDIAN Strut Adapter Plate (on Post 2) and TREND® MEDIAN Angle Strut on the side of Posts 1 & 2 OPPOSITE from the closest traffic, when assembled in a Median or Roadside application. When assembled in a Gore application, it is acceptable to place them on either side of the post.

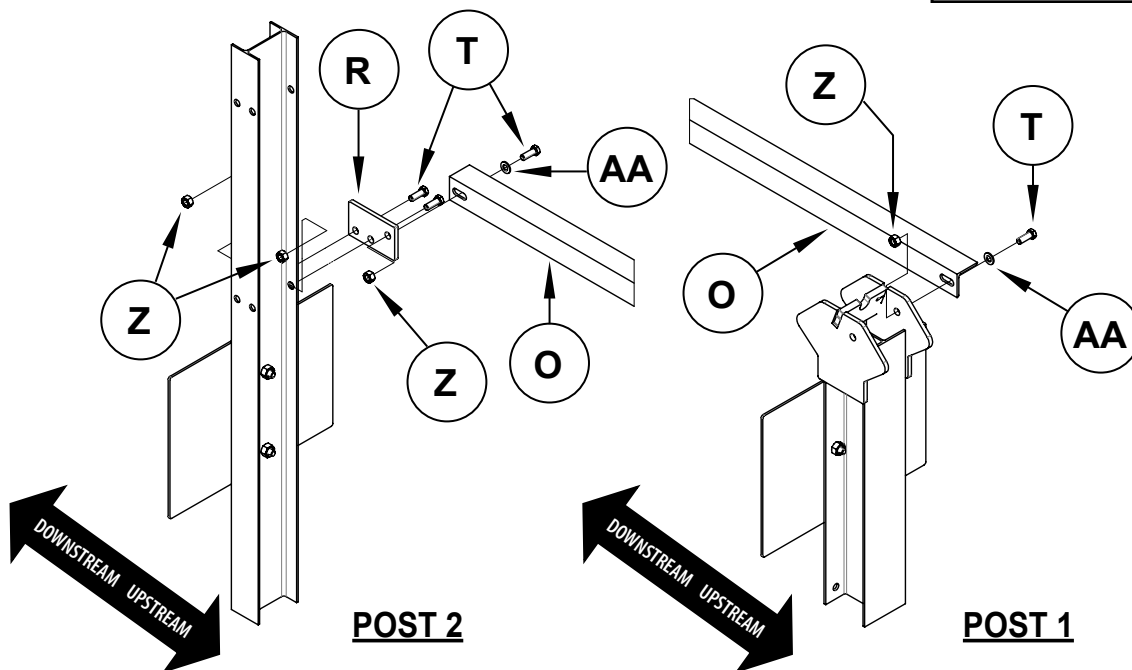
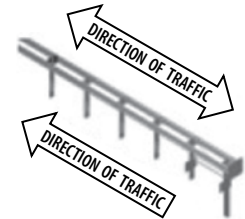

PARTS

O	TREND® MEDIAN Angle Strut	10010445	1 ea
R	TREND® MEDIAN Strut Adapter Plate	10010455	1 ea
T	Hex Bolt M16 x 45 G8.8 HDG AS1252	10009525	4 ea
Z*	M16 Nut CL8 HDG AS1252	10001254	4 ea
AA	M16 Round Washer AS1237.1	10009527	2 ea

INSTRUCTIONS

Reference: TR-MED-001

1. Assemble the TREND® MEDIAN Strut Adapter Plate (Part R) to Post 2 as shown above using specified hardware (Parts T, Z).
2. Assemble the TREND® MEDIAN Angle Strut (Part O) with the "toe" of the vertical leg down and fasten to Posts 1 and the TREND™ MEDIAN Adapter Plate at Post 2, using shown hardware (Parts T, Z, AA).
3. Tighten all threaded hardware to a snug position with a minimum of two (2) bolt threads protruding beyond the nut.

WARNINGS



Ensure the flat washer is between the bolt head and the strut at Post 1 and 2. Ensure the "toe" of the vertical leg of the TREND® MEDIAN Angle Strut is positioned down.
Ensure the threaded hardware is tightened to a snug position with a minimum of two (2) bolt threads protruding beyond the nut. Failure to follow these warnings could result in serious injury or death in the event of a vehicle impact with the system.

STEP 4

TREND® MEDIAN CR Post 1 Top Assembly

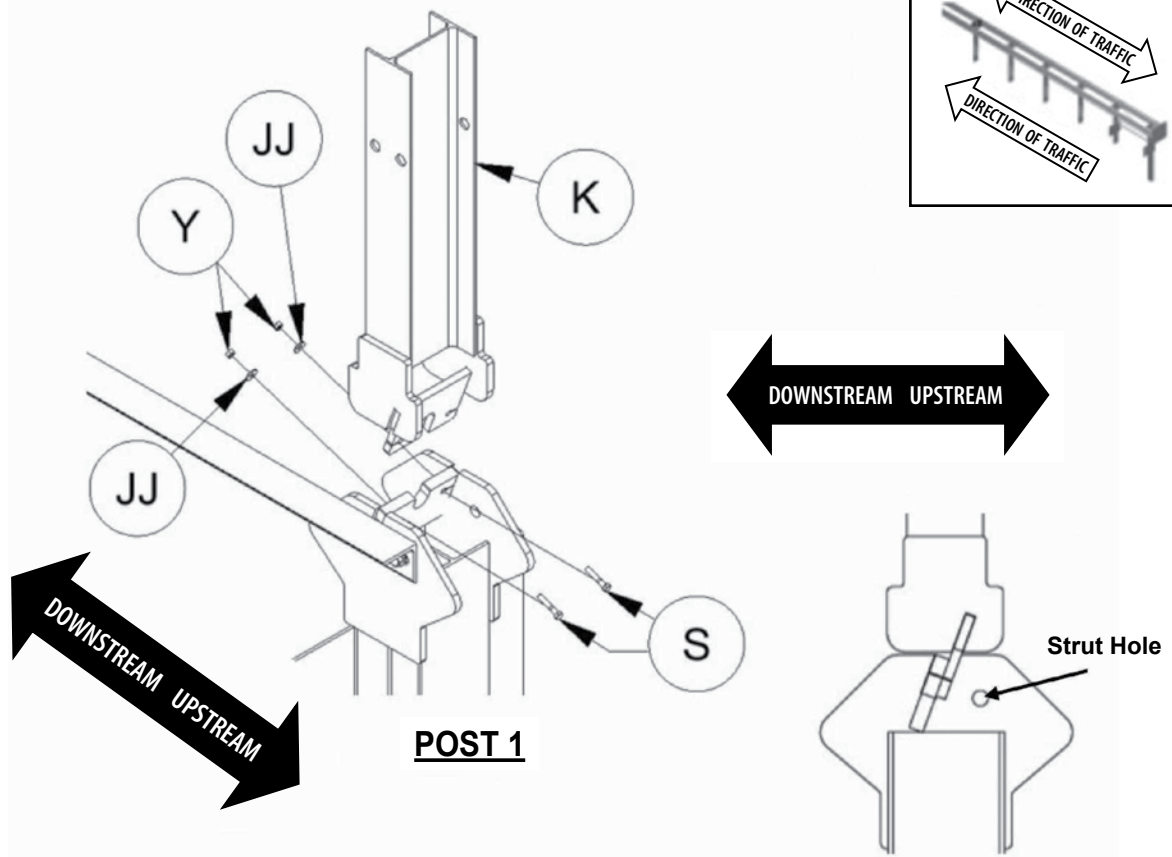

TREND® MEDIAN CR POST 1 TOP ORIENTATION DETAIL

PARTS

K	TREND® MEDIAN CR Post 1 Top	10010448	1 ea
S	M8 x 45mm Hex Set Screw Grade 8.8 Galv	10010125	2 ea
Y	M8 Hex Nut CL8 HDG AS1112.1	10009443	2 ea
JJ	M8 Flat Washer Galv	10001305	2 ea

INSTRUCTIONS

Reference: TR-MED-001

1. Assemble the TREND® MEDIAN CR Post 1 Top (Part K) to the TREND® MEDIAN CR Post 1 Bottom as shown in the "TREND® MEDIAN CR POST 1 TOP ORIENTATION DETAIL" using specified hardware (Parts S, JJ, Y).
2. Tighten all threaded hardware to a snug position with a minimum of two (2) bolt threads protruding beyond the nut.

WARNINGS



Ensure the TREND® MEDIAN CR Post 1 Top is oriented according to the detail above.

Ensure the Strut Hole in the TREND® MEDIAN CR Post 1 Bottom was installed **upstream**. See Step 2A

Ensure threaded hardware is tightened to a snug position with a minimum of two (2) bolt threads protruding beyond the nut. Failure to follow this warning could result in serious injury or death in the event of a vehicle impact with the system.

STEP 5A

TREND® MEDIAN Double Spacer Assembly Post 1 and 2

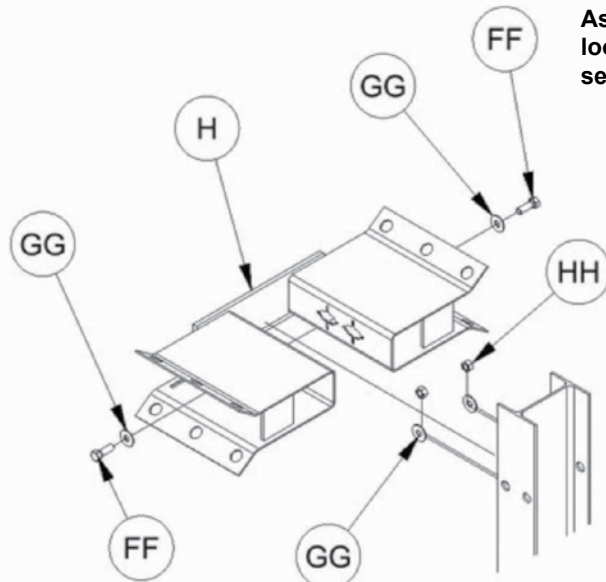

Assemble all hardware loosely ensuring bolt is seated for this step.

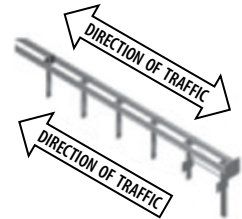

POST 1 AND 2

Bent Flange Pointed Downward

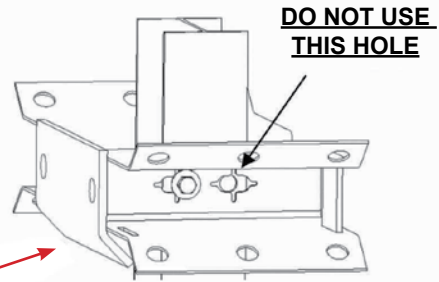

Orientation of the TREND® MEDIAN Outside Spacer Detail

PARTS

H	TREND® MEDIAN Double Spacer	10010446	2 ea
FF	M12 x 45 N/B/W 8.8 CL8 HDG	10001727	4 ea
GG	M12 Round Washer HDG	10001727	8 ea
HH	M12 Hex Nut CL8 HDG	10001727	4 ea

INSTRUCTIONS

Reference: TR-MED-001

1. Assemble the TREND® MEDIAN Double Spacer (Part H) to the TREND® MEDIAN SYTP® (Post 2) and TREND® MEDIAN CR Post 1 as shown above with the **Bent Flange Pointed Downward** using specified hardware (Parts FF, GG, HH).
2. Ensure the **downstream** slotted holes in the TREND® MEDIAN Double Spacer is bolted to the TREND® MEDIAN CR Post 1 and TREND® MEDIAN SYTP® with Soil Plate (Post 2) using the **downstream** holes in the post.

WARNINGS



Ensure the **downstream** slotted holes in the TREND® MEDIAN Double Spacer is bolted to the TREND® MEDIAN CR Post 1 and TREND® MEDIAN SYTP® with Soil Plate (Post 2) using the **downstream** holes in the post. Ensure the TREND® MEDIAN Double Spacer is orientated correctly with the **Bent Flanged Pointed Downward** for Posts 1 and 2. Failure to follow these warnings could result in serious injury or death in the event of a vehicle impact with the system.

STEP 5B

TREND® MEDIAN Single Spacer Assembly Posts 3-5

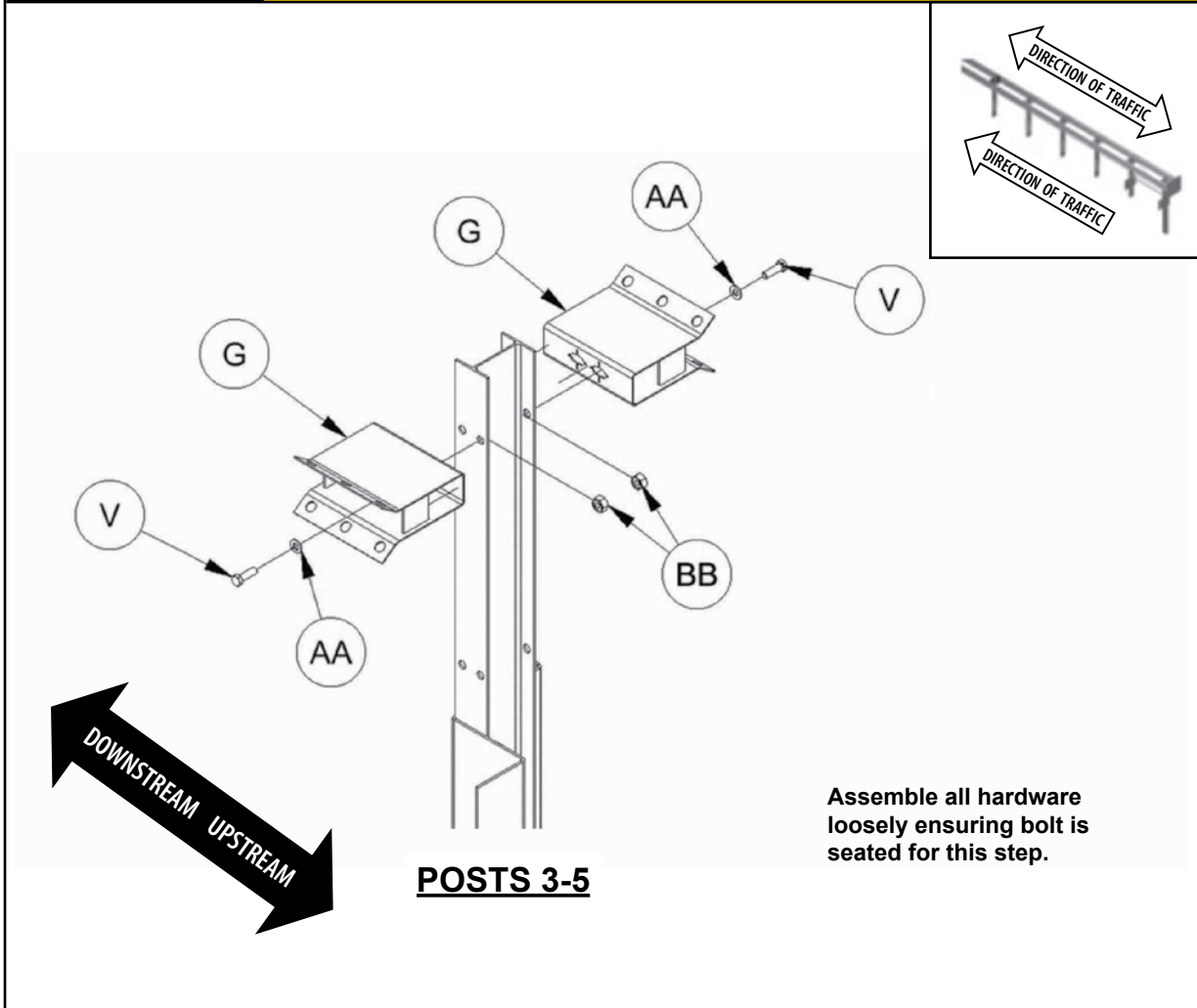

PARTS

G	TREND® MEDIAN Single Spacer	10010447	3 ea
V	Hex Bolt M16 x 50 G8.8 HDG AS1252	10004062	6 ea
AA	M16 Round Washer AS1237.1	10009527	6 ea
BB	M16 Oversize Nut CL8	10001239	6 ea

INSTRUCTIONS

Reference: TR-MED-001

1. Assemble the TREND® MEDIAN hardware (Parts V, AA, BB). 2. Ensure the **upstream** slotted hole in the TREND® MEDIAN Single Spacer is bolted to the TREND® MEDIAN SYTP® with Soil Plate using the **upstream** hole in the post.
3. Ensure all hardware is assembled loosely ensuring bolt is seated for this step.

WARNINGS



Ensure the **upstream** slotted hole in the TREND® MEDIAN Single Spacer is bolted to the TREND® MEDIAN SYTP® with Soil Plate using the **upstream** hole in the post. Failure to follow this warning could result in serious injury or death in the event of a vehicle impact with the system.

STEP 6

TREND® MEDIAN 2.7mm BMT Transition Guardrail with Fin-4, 2.858m

Note: The assembly shown for one side of the post is required for both sides of the post.

Note: At post location 6 only, lap the TREND® MEDIAN 2.7mm BMT Transition Guardrails With Fin-4 to the line guardrail system in the direction of the adjacent traffic. Position the fins upstream.

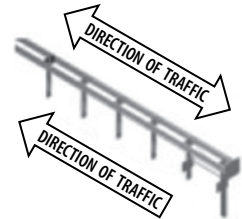
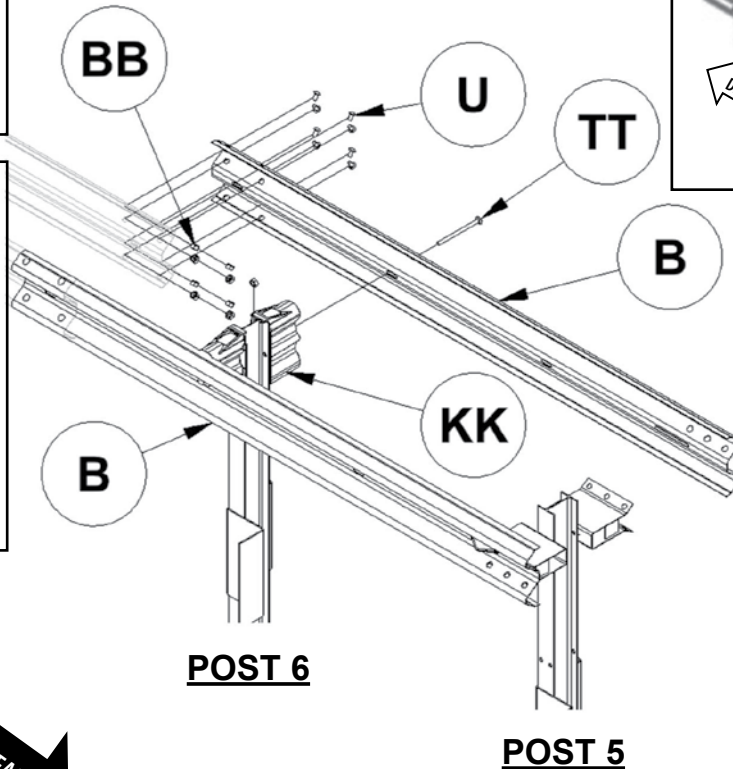

PARTS

B	TREND® MEDIAN 2.7mm BMT Transition Guardrail With Fin-4, 2.858m	10010449	2 ea
U	M16 x 32 Splice Bolt G8.8	10001248	16 ea
BB	M16 Oversize Nut CL8	10001239	18 ea
KK	MASH King Block	10001397	2 ea
TT	M16 x 250mm Terminal Bolt	10009787	2 ea

INSTRUCTIONS

Reference: TR-MED-001

- Assemble the TREND® MEDIAN 2.7mm BMT Transition Guardrail With Fin-4 (Part B), 2.858m as shown above for both sides using specified hardware (Parts U, BB, TT).
- At this location **ONLY**, lap the TREND® MEDIAN 2.7mm BMT Transition Guardrail With Fin-4 with the line guardrail system in the direction of the adjacent traffic. Position the fins upstream.
- Tighten all threaded hardware to a snug position with a minimum of two (2) bolt threads protruding beyond the nut.
- Guardrail height to be 787 mm, [+25 mm, -0 mm] above finished grade.

WARNINGS



Ensure the TREND® MEDIAN 2.7mm BMT Transition Guardrail With Fin-4 at this location **ONLY** is lapped with the line guardrail in the direction of adjacent traffic.

Ensure the fins are positioned upstream. Ensure only 200mm Composite Offset Blocks are used. Failure to follow these warnings could result in serious injury or death in the event of a vehicle impact with the system.

STEP 7

TREND® MEDIAN 2.7mm BMT Slotted Intermediate Rail with Fin-3, 1.905m Post 4-5

Note: The assembly shown for one side of the post is required for both sides of the post.

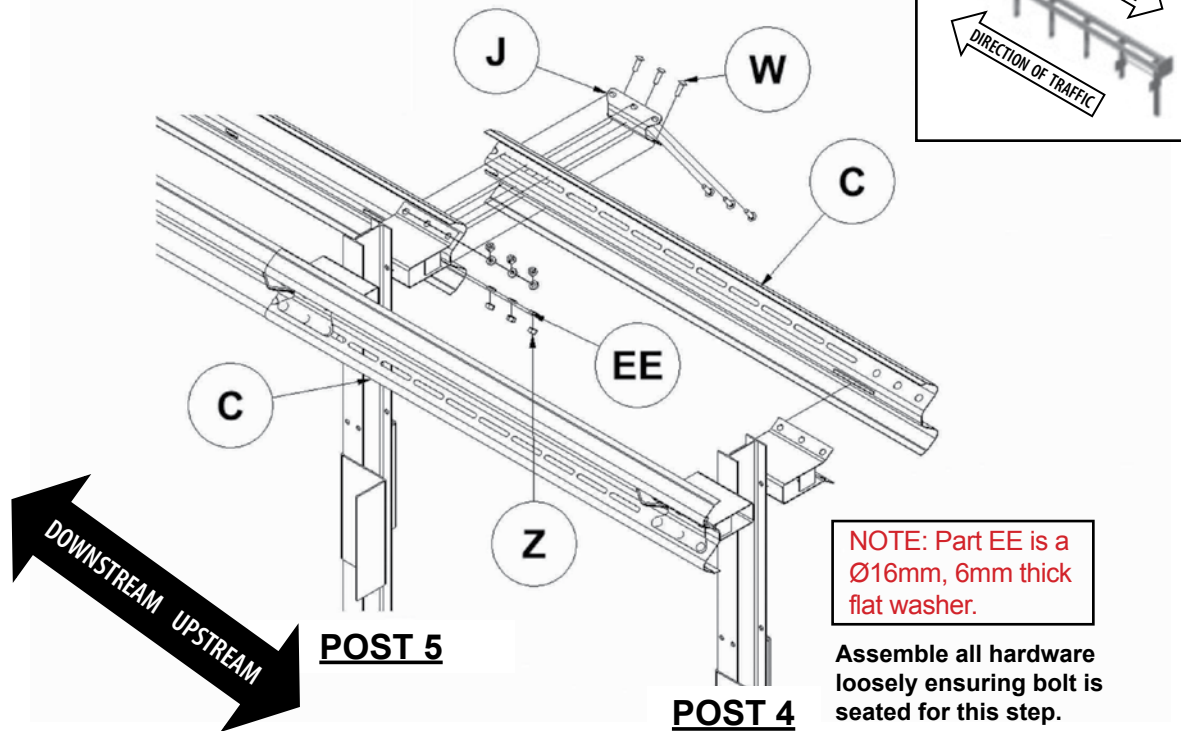

PARTS

C	TREND® MEDIAN 2.7mm BMT, Slotted Intermediate Guardrail With Fin-3,1.905m	10010450	2 ea
J	TREND® MEDIAN Backing Plate	10010451	2 ea
W	M16 x 50 Post Bolt G8.8 HDG AS1252	10004030	12 ea
Z	M16 Nut CL8 HDG AS1252	10001254	12 ea
EE	M16 Flat Washer OD 35mm Thickness 6mm	10007653	12 ea

INSTRUCTIONS

Reference: TR-MED-001

1. Assemble the TREND® MEDIAN 2.7mm BMT Slotted Intermediate Guardrail With Fin-3 (Part C), 1.905m as shown above for both sides using specified hardware (Parts J, W, Z, EE).
2. Ensure the TREND® MEDIAN 2.7mm BMT Slotted Intermediate Guardrail With Fin-3 installed between Posts 4 and 5 **is lapped to the outside** of the TREND® MEDIAN 2.7mm BMT Transition Guardrail With Fin-4 and fins are positioned upstream.
3. Ensure the TREND® MEDIAN Backing Plate (Part J) **is on the outside** of the TREND® MEDIAN 2.7mm BMT Slotted Intermediate Guardrail With Fin-3.
4. Assemble all hardware loosely ensuring bolt is seated for this step.

WARNINGS



Ensure the TREND® MEDIAN 2.7mm BMT Slotted Intermediate Guardrail With Fin-3 installed between Posts 4 and 5 **is lapped to the outside** of the TREND® MEDIAN 2.7mm BMT Transition Guardrail With Fin-4. Ensure the TREND® MEDIAN Backing Plate **is on the outside** of the TREND® MEDIAN 2.7mm BMT Slotted Intermediate Guardrail With Fin-3. Ensure the fins are positioned upstream as shown. Failure to follow these warnings could result in serious injury or death in the event of a vehicle impact with the system

STEP 8

TREND® MEDIAN 2.7mm BMT Slotted Intermediate Guardrail With Fin-3, 1.905m

Note: The assembly shown for one side of the post is required for both sides of the post.

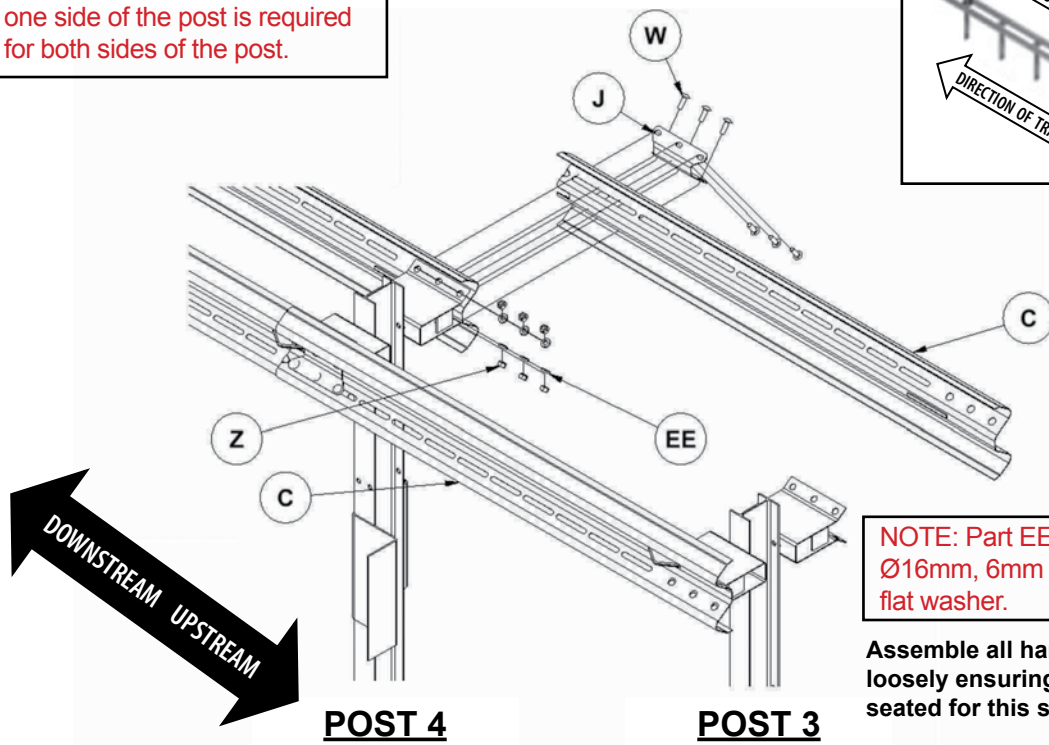

NOTE: Part EE is a Ø16mm, 6mm thick flat washer.

Assemble all hardware loosely ensuring bolt is seated for this step.

PARTS

C	TREND® MEDIAN 2.7mm BMT, Slotted Intermediate Guardrail With Fin-3, 1.905m	10010450	2 ea
J	TREND® MEDIAN Backing Plate	10010451	2 ea
W	M16 x 50 Post Bolt G8.8 HDG AS1252	10004030	12 ea
Z	M16 Nut CL8 HDG AS1252	10001254	12 ea
EE	M16 Flat Washer OD 35mm Thickness 6mm	10007653	12 ea

INSTRUCTIONS

Reference: TR-MED-001

1. Assemble the TREND® MEDIAN 2.7mm BMT Slotted Intermediate Guardrail with Fin-3 (Part C), 1.905m as shown above for both sides using specified hardware (Parts J, W, Z, EE).
2. Ensure the TREND® MEDIAN 2.7mm BMT Slotted Intermediate With Fin-3 installed between Posts 3 and 4 **is lapped to the outside** of the TREND® MEDIAN 2.7mm BMT Slotted Intermediate Guardrail With Fin-3 installed between posts 4 and 5
3. Ensure the TREND® MEDIAN Backing Plate (Part J) **is on the outside** of the TREND® MEDIAN 2.7mm BMT Slotted Intermediate With Fin-3.
4. Assemble all hardware loosely ensuring bolt is seated for this step.

WARNINGS



Ensure the TREND® MEDIAN 2.7mm BMT Slotted Intermediate With Fin-3 installed between Posts 3 and 4 **is lapped to the outside** of the TREND® MEDIAN 2.7mm BMT Slotted Intermediate Guardrail With Fin-3 installed between posts 3 and 4. Ensure the TREND® MEDIAN Backing Plate **is on the outside** of the TREND® MEDIAN 2.7mm BMT Slotted Intermediate Guardrail With Fin-3. Ensure fins are positioned upstream as shown. Failure to follow these warnings could result in serious injury or death in the event of a vehicle impact with the system.

STEP 9

TREND® MEDIAN 2.7mm BMT Slotted Intermediate Guardrail-2, 1.905m

Note: The assembly shown for one side of the post is required for both sides of the post.

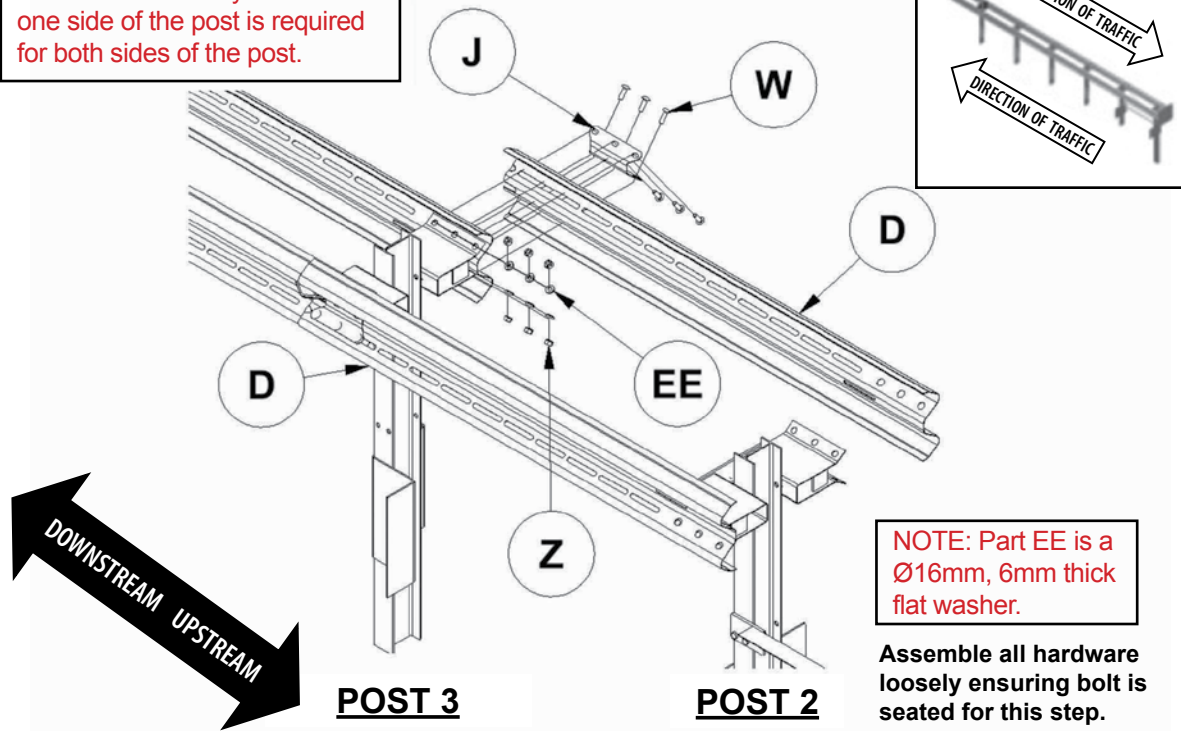

NOTE: Part EE is a Ø16mm, 6mm thick flat washer.

Assemble all hardware loosely ensuring bolt is seated for this step.

PARTS

D	TREND® MEDIAN 2.7mm BMT, Slotted Intermediate Guardrail-2, 1.905m	10010442	2 ea
J	TREND® MEDIAN Backing Plate	10010451	2 ea
W	M16 x 50 Post Bolt G8.8 HDG AS1252	10004030	12 ea
Z	M16 Nut CL8 HDG AS1252	10001254	12 ea
EE	M16 Flat Washer OD 35mm Thickness 6mm	10007653	12 ea

INSTRUCTIONS

Reference: TR-MED-001

1. Assemble the TREND® MEDIAN 2.7mm BMT Slotted Intermediate Guardrail-2 (Part D), 1.905m as shown above for both sides using specified hardware (Parts J, W, Z, EE).
2. Ensure the TREND® MEDIAN 2.7mm BMT Slotted Intermediate Guardrail-2 installed between Posts 2 and 3 **is lapped to the outside** of the TREND® MEDIAN 2.7mm BMT Slotted Intermediate Guardrail With Fin-3 installed between posts 3 and 4.
3. Ensure the TREND® MEDIAN Backing Plate (Part J) **is on the outside** of the TREND® MEDIAN 2.7mm BMT Slotted Intermediate Guardrail-2.
4. Assemble all hardware loosely ensuring bolt is seated for this step.

WARNINGS



Ensure the TREND® MEDIAN 2.7mm BMT Slotted Intermediate Guardrail-2 installed between Posts 2 and 3 **is lapped to the outside** of the TREND® MEDIAN 2.7mm BMT Slotted Intermediate Guardrail With Fin-3 installed between posts 3 and 4.

Ensure the TREND® MEDIAN Backing Plate (Part J) **is on the outside** of the TREND® MEDIAN 2.7mm BMT Slotted Intermediate Guardrail-2. Ensure fins are positioned upstream as shown. Failure to follow these warnings could result in serious injury or death in the event of a vehicle impact with the system.

STEP 10

TREND® MEDIAN 3.4mm BMT Slotted Front Guardrail-1 1.905m

Note: The assembly shown for one side of the post is required for both sides of the post.

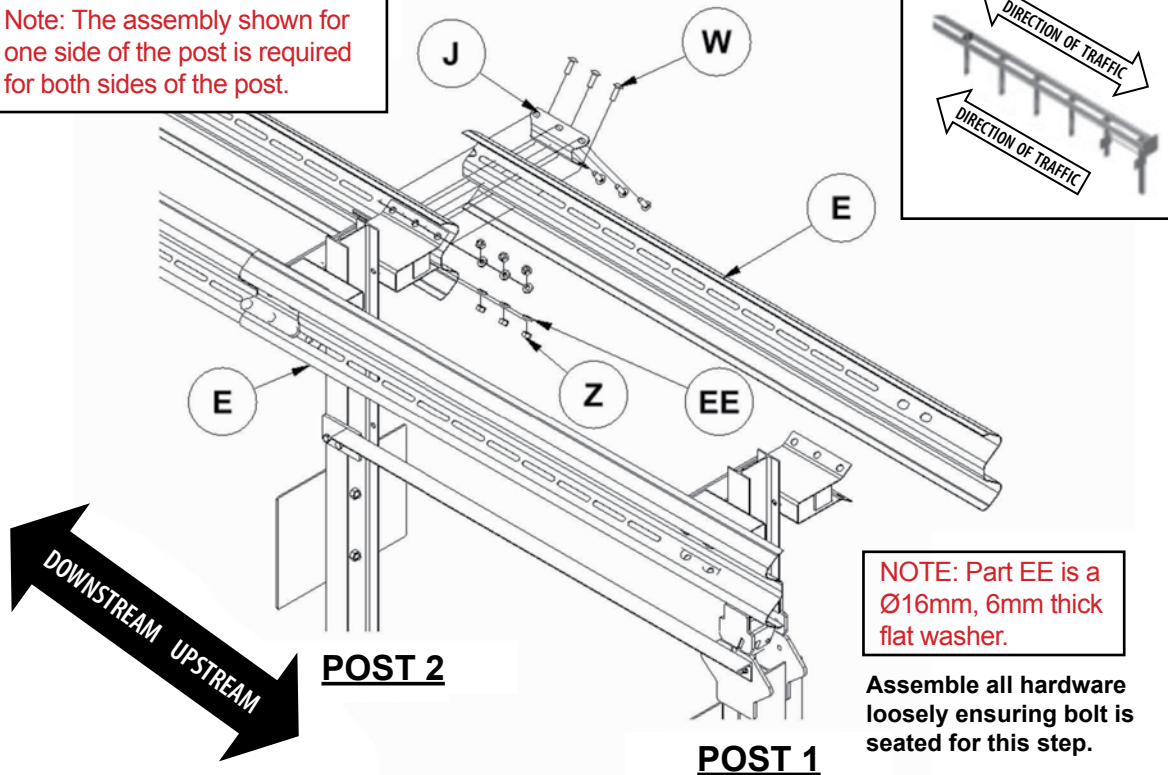

NOTE: Part EE is a Ø16mm, 6mm thick flat washer.

Assemble all hardware loosely ensuring bolt is seated for this step.

PARTS

E	TREND® MEDIAN 3.4mm BMT, Slotted Front Guardrail-1, 1.905 m	10010454	2 ea
J	TREND® MEDIAN Backing Plate	10010451	2 ea
W	M16 x 50 Post Bolt G8.8 HDG AS1252	10004030	12 ea
Z	M16 Nut CL8 HDG AS1252	10001254	12 ea
EE	M16 Flat Washer OD 35mm Thickness 6mm	10007653	12 ea

INSTRUCTIONS

Reference: TR-MED-001

1. Assemble the TREND® MEDIAN Backing Plate (Part J) and TREND® MEDIAN 3.4mm BMT Slotted Front Guardrail-1 (Part E), 1.905m to the TREND® MEDIAN 2.7mm BMT Slotted Intermediate Guardrail-2 as shown above for both sides using specified hardware (Parts W, Z, EE).
2. Ensure the TREND® MEDIAN 3.4mm BMT Slotted Front Guardrail-1 **is lapped to the outside** of the TREND® MEDIAN 2.7mm BMT Slotted Intermediate Guardrail-2
3. Ensure the TREND® MEDIAN Backing Plate **is on the outside** of the TREND® MEDIAN 3.4mm BMT Slotted Front Guardrail-1.
4. Assemble all hardware loosely ensuring bolt is seated for this step.

WARNINGS



Ensure the TREND® MEDIAN 3.4mm BMT Slotted Front Guardrail-1 **is lapped to the outside** of the TREND® MEDIAN 2.7mm BMT Slotted Intermediate Guardrail-2.

Ensure the TREND® MEDIAN Backing Plate **is on the outside** of the TREND® MEDIAN 3.4mm BMT Slotted Front Guardrail-1.

Failure to follow these warnings could result in serious injury or death in the event of a vehicle impact with the system.

STEP 11

TREND® MEDIAN Cable Assembly

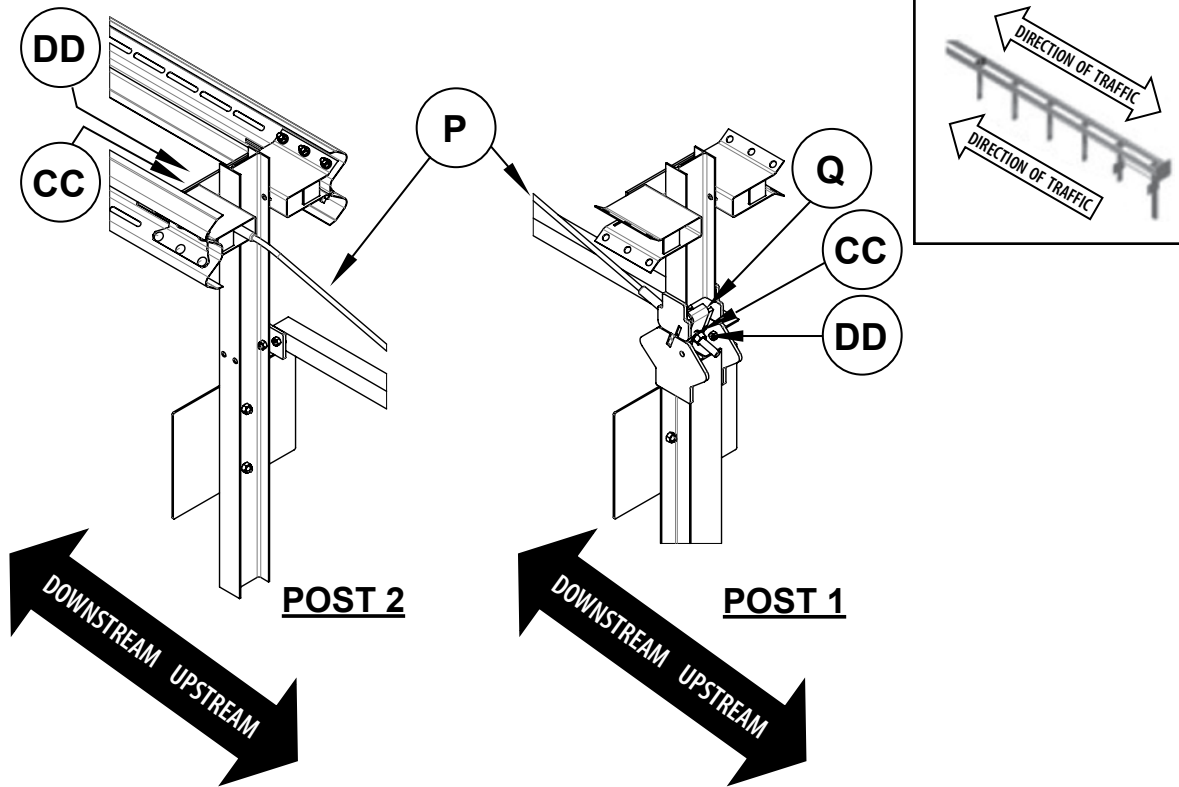

PARTS

P	TREND® MEDIAN Cable Assembly 19 mm x 2.260m	10010457	1 ea
Q	Cable Anchor Bracket Angle	10010456	1 ea
CC	25mm Flat Washer	10002161	2 ea
DD	25mm Hex Nut	10007549	2 ea

INSTRUCTIONS

Reference: TR-MED-001

1. Assemble the TREND® MEDIAN Cable Assembly [Part P] as shown above using specified hardware (Parts Q, CC, DD), remove excess slack from the cable.
2. Ensure that the bent portion of the Cable Anchor Bracket Angle [Part Q] at CR Post 1 is up and hooked over the TREND® MEDIAN CR Post 1 Top.

WARNINGS



Ensure the Cable Anchor Bracket Angle is hooked over the TREND® MEDIAN CR Post 1 Top. Failure to follow these warnings could result in serious injury or death in the event of a vehicle impact with the system.

STEP 12

TREND® MEDIAN 3.4mm BMT Head Rail Assembly 552 mm

Note: The assembly shown for one side of the post is required for both sides of the post.

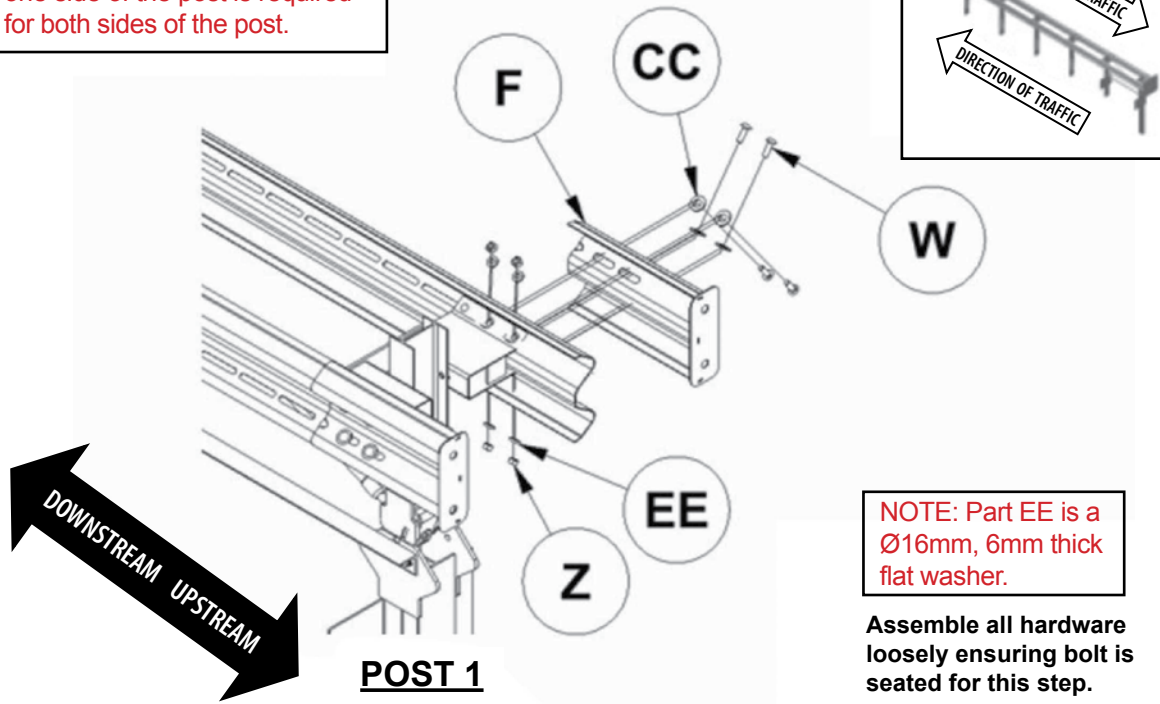

NOTE: Part EE is a Ø16mm, 6mm thick flat washer.

Assemble all hardware loosely ensuring bolt is seated for this step.

PARTS

F	TREND® MEDIAN 3.4mm BMT Head Rail, 552mm	10010452	2 ea
W	M16 x 50 Post Bolt G8.8 HDG AS1252	10004030	8 ea
Z	M16 Nut CL8 HDG AS1252	10001254	8 ea
CC	25mm Flat Washer	10002161	8 ea
EE	M16 Flat Washer OD 35mm Thickness 6mm	10007653	8 ea

INSTRUCTIONS

Reference: TR-MED-001

1. Assemble the TREND® MEDIAN 3.4mm BMT Head Rail (Part F), 552mm to the TREND® MEDIAN 3.4mm BMT Slotted Front Guardrail-1 as shown above for both sides using specified hardware (Parts W, CC, EE, Z).
2. Ensure the two Upstream holes in the TREND® MEDIAN Double Spacer are used to assemble the TREND® MEDIAN 3.4mm BMT Head Rail and TREND® MEDIAN 3.4mm BMT Slotted Front Guardrail-1.
3. Ensure the TREND® MEDIAN 3.4mm BMT Head Rail **is lapped to the outside** of the TREND® MEDIAN 3.4mm BMT Slotted Front Guardrail-1.
4. Assemble all hardware loosely ensuring bolt is seated for this step

WARNINGS



Ensure the TREND® MEDIAN 3.4mm BMT Head Rail is lapped to the outside of the TREND® MEDIAN 3.4mm BMT Slotted Front Guardrail-1.

Ensure the two Upstream holes in the TREND® MEDIAN Double Spacer are used to assemble the TREND® MEDIAN 3.4mm BMT Head Rail.

Failure to follow this warning could result in serious injury or death in the event of a vehicle impact with the system.

STEP 13

TREND® MEDIAN Delineation Assembly

Note: The Delineation Sheeting must be notched in four (4) places for the gusset plates.

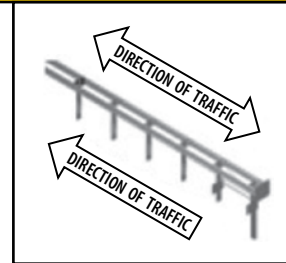
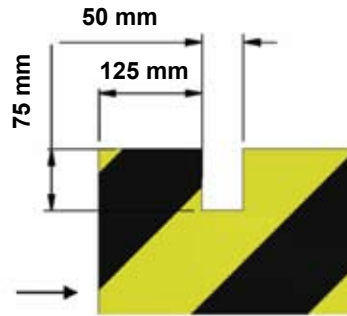

NOTH DETAIL TYPICAL AT 4 GUSSET PLATES



Roadside



Gore

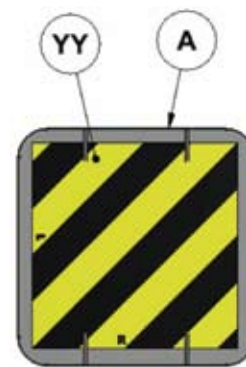

Median

PARTS

A	TREND® MEDIAN Impact Head	10010453	1 ea
YY	625 mm x 625 mm Yellow/Black Reflector (Median/Roadside)	105379B	1 ea
OR			
ZZ	625 mm x 625 mm Yellow/Black Reflector (Gore)	105380B	1 ea

INSTRUCTIONS

Reference: TR-MED-001

1. For median/roadside application, attach the Delineation Sheeting (Part YY) to the TREND® MEDIAN Impact Head (Part A) as shown above. Rotate as appropriate.

2. For gore application, attach the Delineation Sheeting (Part ZZ) to the TREND® MEDIAN Impact Head (Part A).

Note: Manufacturer suggests that user provide delineation (reflective sheeting) as required by the state/specifying agency for terminals.

Note: Ingal Civil Products offers two (2) specific reflective sheeting options for an additional charge. Ingal Civil Products makes no guarantees they meet the minimum specifications, comply with MUTCD requirements or comply with state/specifying agency requirements

WARNINGS



Ensure delineation (reflective sheeting) used on the TREND® MEDIAN Impact Head meets state/specifying agency's MUTCD for proper delineation.

Ensure steel delineator posts are a minimum of 1m in front (upstream) of the TREND® MEDIAN.

Failure to follow these warnings could result in serious injury or death in the event of a vehicle impact with the system.

STEP 14

TREND® MEDIAN Head Tube Assembly

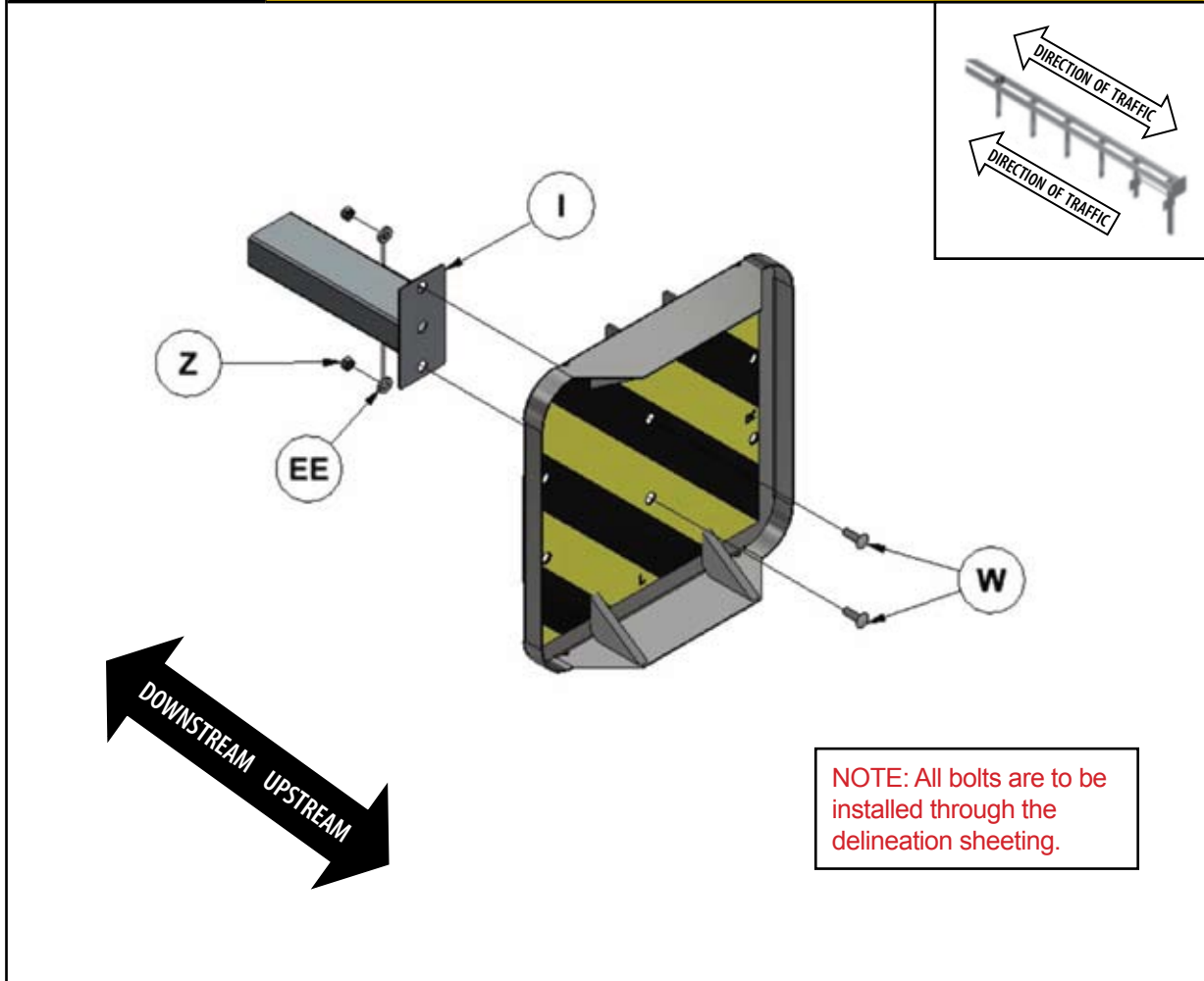

NOTE: All bolts are to be installed through the delineation sheeting.

PARTS

I	TREND® MEDIAN Head Tube	10010443	1 ea
W	M16 x 50 Post Bolt G8.8 HDG AS1252	10004030	2 ea
Z	M16 Nut CL8 HDG AS1252	10001254	2 ea
EE	M16 Flat Washer OD 35mm Thickness 6mm	10007653	2 ea
628342A, from Step 13			

INSTRUCTIONS

Reference: TR-MED-001

- Assemble the TREND® MEDIAN Head Tube (Part I) to the TREND® MEDIAN Impact Head as shown above using specified hardware (Parts W, Z, EE).
- Insert M16 x 50 GR Bolt through the delineation sheeting and tighten the M16 Heavy Hex Nut used to assemble the TREND® MEDIAN Head Tube to the TREND® MEDIAN Impact Head to **88 Nm [+/- 4 Nm]** using a calibrated torque wrench.

WARNINGS



Ensure the M16 Heavy Hex Nut used to assemble the TREND® MEDIAN Head Tube to the TREND® MEDIAN Impact Head is tightened to a torque of **88 Nm [+/- 4 Nm]** using a calibrated torque wrench. Failure to follow this warning could result in serious injury or death in the event of a vehicle impact with the system.

STEP 15

TREND® MEDIAN Impact Head Assembly

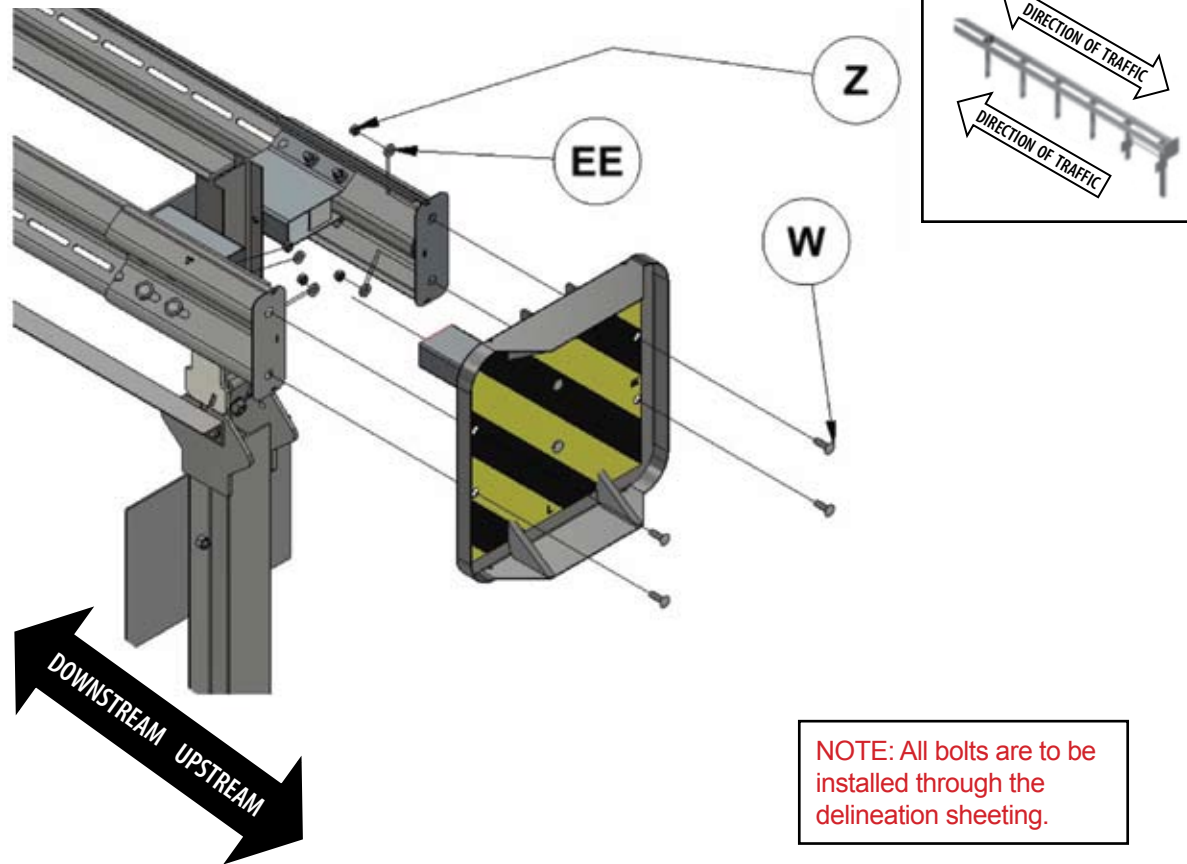

NOTE: All bolts are to be installed through the delineation sheeting.

PARTS

W	M16 x 50 Post Bolt G8.8 HDG AS1252	10004030	4 ea
Z	M16 Nut CL8 HDG AS1252	10001254	4 ea
EE	M16 Flat Washer OD 35mm Thickness 6mm	10007653	4 ea
	628342A, from Step 13		

INSTRUCTIONS

Reference: TR-MED-001

1. Assemble the TREND® MEDIAN Impact Head to the TREND® MEDIAN 3.4mm BMT Head Rail as shown above using specified hardware (Parts W, Z, EE).
2. Insert M16 x 50 GR Bolt through the delineation sheeting and tighten the M16 Heavy Hex Nut used to Assemble the TREND® MEDIAN Head Tube to the TREND® MEDIAN Impact Head, to **88 Nm [+/- 4 Nm]** using a calibrated torque wrench.
3. Ensure the TREND® MEDIAN Head Tube is touching the TREND® MEDIAN CR Post 1 Top by pushing the TREND® MEDIAN Impact Head and the TREND® MEDIAN 3.4mm BMT Head Rails back evenly.

WARNINGS



Ensure 5/8" Heavy Hex Nuts attaching the TREND® MEDIAN Impact Head to the TREND® MEDIAN 3.4mm BMT Head Rail are **torqued to 88 Nm [+/- 4 Nm]** using a calibrated torque wrench.

Ensure the TREND® MEDIAN Head Tube is touching the TREND® MEDIAN CR Post 1 Top.

Failure to follow these warnings could result in serious injury or death in the event of a vehicle impact with the system.

STEP 16

TREND® MEDIAN Nuts To Be Torqued And Cable Tensioning

Number in balloon represents the number of “W”, M16 x 50 G8.8 GR Bolts and “Z”, M16 Oversize Nuts, that are torqued to 88 Nm, [+/-4 Nm], at each location.

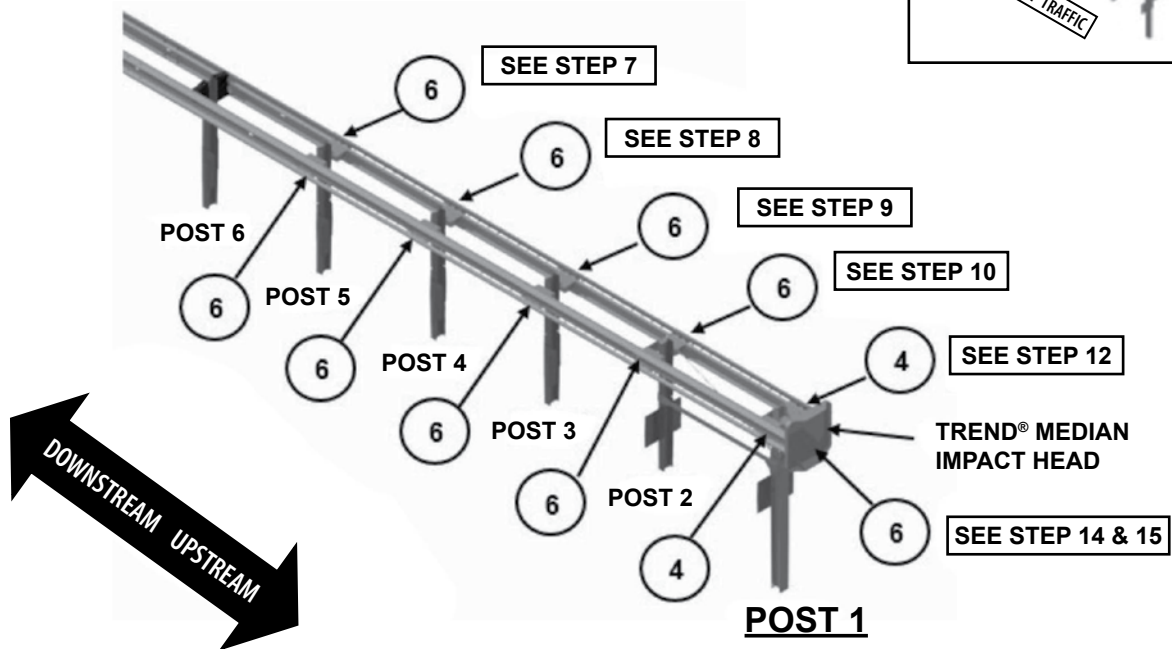
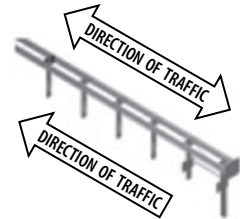

PARTS

INSTRUCTIONS

Reference: TR-MED-001

1. Ensure all bolts identified above and installed loosely ensuring bolt is seated for this step in earlier Steps are **torqued to 88 Nm [+/-4 Nm]** using a calibrated torque wrench.
2. Ensure the 1" flat washers installed in Step 14 under the bolt head attaching the TREND® MEDIAN 3.4mm BMT Head Rail are centered on the bolt head before tightening.
3. Ensure that the bent portion of the Cable Anchor Bracket Angle (See Step 11) at CR Post 1 is up and hooked over the TREND® MEDIAN CR Post 1 Top.
4. Restrain the cable with locking pliers and/or a pipe wrench while tightening nut with a wrench, at the end being tightened to avoid twisting the cable.
5. Tighten the cable until it is taut. The cable is considered taut when it does not deflect more than 25 mm when pressure is applied by hand in an up or down direction.

WARNINGS



Ensure all bolts identified above and installed loosely ensuring bolt is seated for this step in earlier Steps are **torqued to 88 Nm [+/- 4 Nm]** using a calibrated torque wrench. Ensure the 1" flat washers installed in Step 14 under the bolt head attaching the TREND® MEDIAN 3.4mm BMT Head Rail are centered on the bolt head before tightening. Ensure cable is taut.

Failure to follow these warnings could result in serious injury or death in the event of a vehicle impact with the system.

9.0 TREND[®] MEDIAN Assembly/Repair Checklist (File with Project/Maintenance Records)

Performed by: _____

Date: _____

Location: _____

Ensure proper site grading complies with state/specifying agency guidelines and/or Austroads Guide to Road Design, whichever is more stringent (p 8).	<input type="checkbox"/>
Ensure only Ingal Civil Products provided parts are used for the assembly of the terminal and that all parts are free of damage (p 5).	<input type="checkbox"/>
Under NO circumstances shall the rail within the terminal be curved.	<input type="checkbox"/>
Ensure the soil around all posts is properly compacted and posts are free to rotate. When leave outs are necessary, use only state/specifying agency approved backfill material within the leave out area (p 9).	<input type="checkbox"/>
Ensure the Strut Hole of the CR Post 1 Bottom with Soil Plate is upstream and the Post is 100 mm [+25 mm, -0 mm] above the finished grade (pp 17, 21-22).	<input type="checkbox"/>
Ensure Soil Plates are installed on the downstream side of Posts 1-6 (pp 17-20).	<input type="checkbox"/>
Ensure the center of the SYTP [®] yielding holes at Posts 2-5 are approximately centered at finished grade (pp 18-19).	<input type="checkbox"/>
Ensure the Angle Strut is installed between Post 1 and 2 on the post side OPPOSITE the closest traffic, when assembled in a Median or Roadside application. When assembled in a Gore application, it is acceptable to place them on either side of the post(s). Ensure the toe of the Strut's vertical leg is pointed down (p 21).	<input type="checkbox"/>
Ensure the downstream slotted holes in the Double Spacer is bolted to the downstream hole of the CR Post 1 Top and the SYTP [®] (Post 2) (p 23).	<input type="checkbox"/>
Ensure the upstream slotted hole in the Spacer (Posts 3-5) is bolted to the SYTP [®] with Soil Plate using the upstream hole in the post (p 24).	<input type="checkbox"/>
Ensure all W-beam rails are installed 787mm [+25 mm, -0 mm] from finished grade (pp various).	<input type="checkbox"/>
Ensure all 2.7mm BMT Transition Guardrails With Fin-4, at post location 6, are lapped in the direction of the nearest adjacent traffic and fins are positioned upstream (p 25).	<input type="checkbox"/>
Ensure the 2.7mm BMT, Slotted Intermediate Guardrails With Fin-3 are lapped to the outside of the 2.7mm BMT Transition Guardrails with Fin-4 (p 26).	<input type="checkbox"/>
Ensure the 2.7mm BMT, Slotted Intermediate Guardrails With Fin-3 are lapped to the outside of the 2.7mm BMT, Slotted Intermediate Guardrails With Fin-3 (p 27).	<input type="checkbox"/>
Ensure the 2.7mm BMT, Slotted Intermediate Guardrails-2 are lapped to the outside of the 2.7mm BMT, Slotted Intermediate Guardrails With Fin-3 (p 28).	<input type="checkbox"/>
Ensure the 3.4mm BMT, Slotted Front Guardrails-1 are lapped to the outside of the 2.7mm BMT, Slotted Intermediate Guardrails-2 (p 29).	<input type="checkbox"/>
Ensure the 3.4mm BMT Head Rails are lapped to the outside of the 3.4mm BMT Slotted Front Guardrails-1 (p 31).	<input type="checkbox"/>
Ensure the Backing Plate is assembled on the outside of the Guardrail Panels at Posts 2, 3, 4 and 5 (pp 26-29).	<input type="checkbox"/>
Ensure the M16 heavy flat washers (6mm thick) are placed between the nut and spacers at Posts 1-5. (pp 26-29)	<input type="checkbox"/>
Ensure the Head Tube is attached to the Impact Head and it is up against the CR Post 1 Top (pp 33-34).	<input type="checkbox"/>
Ensure all fasteners identified in Step 16 are torqued to 88 Nm, [+/- 4 Nm] (p 35).	<input type="checkbox"/>
Ensure all fasteners that are NOT required to be torqued are tightened to a snug position with a minimum of two (2) bolt threads protruding beyond the nut (Various pp).	<input type="checkbox"/>
Ensure the Cable Anchor Bracket Angle is hooked over the CR Post 1 Top and the cable is taut (pp 30-35).	<input type="checkbox"/>

10.0 TREND® MEDIAN Routine Inspection Checklist (File with Project/Maintenance Records)

Performed by: _____

Date: _____

Location: _____

Ingal Civil Products recommends the state/specifying agency develop and administer their own end terminal inspection program, based on location of unit, volume of traffic and impact history.



IMPORTANT: The TREND® MEDIAN and all of its components shall be inspected for damage after every impact. Repair using only Ingal Civil Products parts that are specified for use within this TREND® MEDIAN Product Description Assembly Manual.

If no end terminal inspection program exists, Trinity Highway recommends visual drive-by inspections at least once every month and walk-up inspections every six (6) months. These inspections shall, at a minimum, consist of:

Walk-Up Inspections (Recommended Frequency: Every Six (6) Months)

Walk-Up Inspections include ALL Visual Drive-By Inspection items (listed above) as well as the items listed below.

Ensure required traffic control is in place to conduct walk-up inspection.	<input type="checkbox"/>
Clear and dispose of any debris or trash found on the TREND® MEDIAN site, which may interfere with the performance of the TREND® MEDIAN .	<input type="checkbox"/>
Check that fasteners are fully tightened. See Step 16 for torqued nut locations. All other locations are to be tightened to a snug position with a minimum of two (2) bolt threads protruding beyond the nut.	<input type="checkbox"/>
Check for erosion to the site grading around the system.	<input type="checkbox"/>
Ensure that the TREND® MEDIAN Anchor Cable is taut and the Bearing Plate is properly positioned.	<input type="checkbox"/>
Ensure the TREND® MEDIAN Panels are lapped correctly to allow them to telescope.	<input type="checkbox"/>

If any of the above items are identified during the inspection process, swift action shall be taken to correct and repair the TREND® MEDIAN to working condition as outlined in the TREND® MEDIAN Product Description Assembly Manual, latest edition.

11.0 Appendix A

AASHTO Roadside Design Guide Roadside (Shoulder) Grading Detail

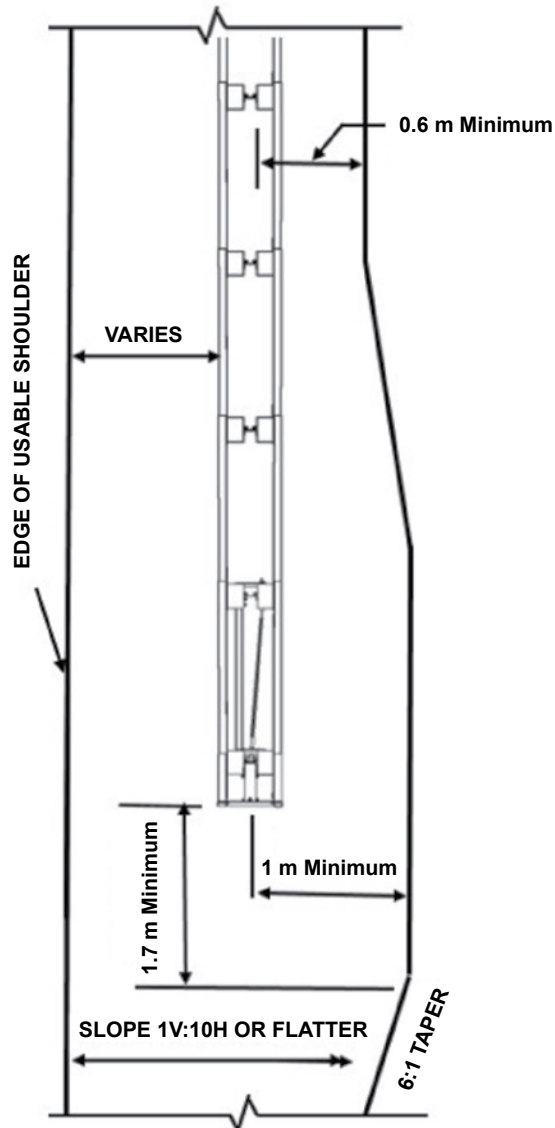

NOTE: Refer to AASHTO Roadside Design Guide, 4th Edition 2011, Section 8.3.3 Site Grading Consideration for Terminals, pp 8-4 through 8-6.

TREND[®] MEDIAN Roadside (Shoulder) Grading Detail

Detail derived from information contained in the AASHTO Roadside Design Guide, 4th Edition 2011



IMPORTANT: Ingal Civil Products does not direct grading. Proper site grading must be accomplished before assembly of the TREND[®] MEDIAN System in accordance with state/specifying agency guidelines or the AASHTO Roadside Design Guide, whichever is more stringent. Failure to follow this warning could result in serious injury or death in the event of a vehicle impact with the system.

12.0 Appendix B

AASHTO Roadside Design Guide Median Grading Detail

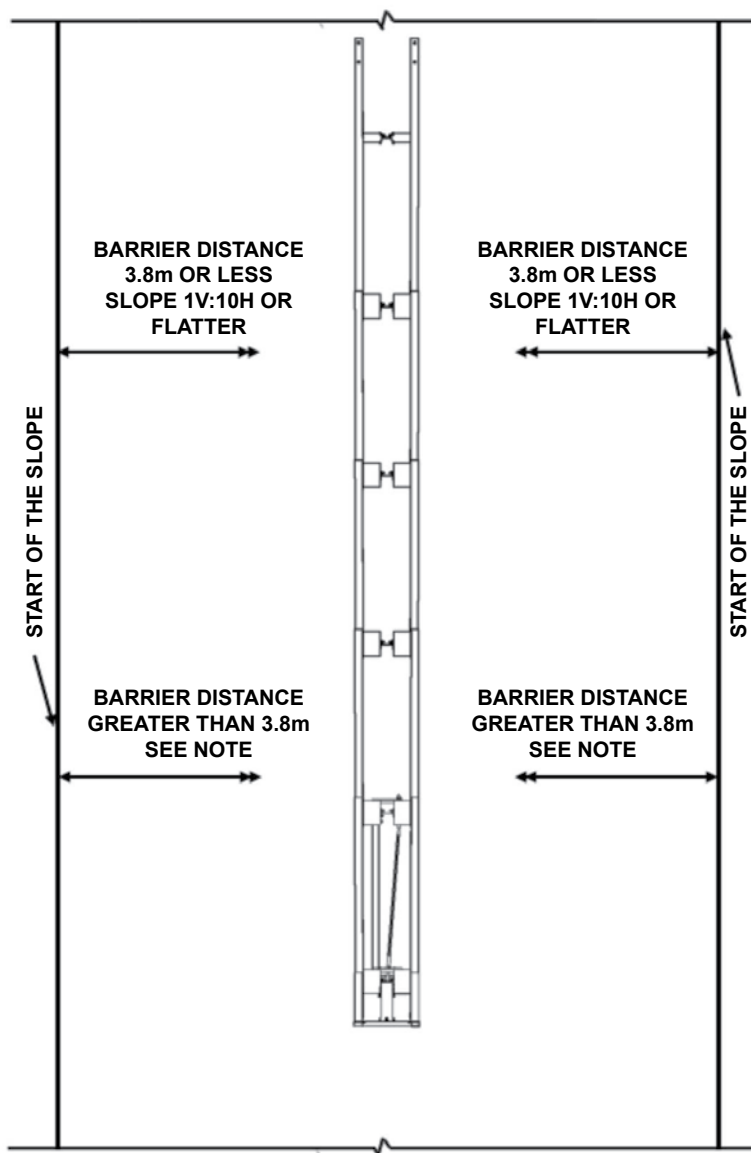

NOTE: Refer to AASHTO Roadside Design Guide, 4th Edition 2011, Section 5.6.2.2 Slopes, pp 5-46 through 5-48 for slope criteria.

TREND[®] MEDIAN Median Grading Detail

Detail derived from information contained in the AASHTO Roadside Design Guide, 4th Edition 2011



IMPORTANT: Ingal Civil Products does not direct grading. Proper site grading must be accomplished before assembly of the MATT™ System in accordance with state/specifying agency guidelines or the AASHTO Roadside Design Guide, whichever is more stringent. Failure to follow this warning could result in serious injury or death in the event of a vehicle impact with the system.

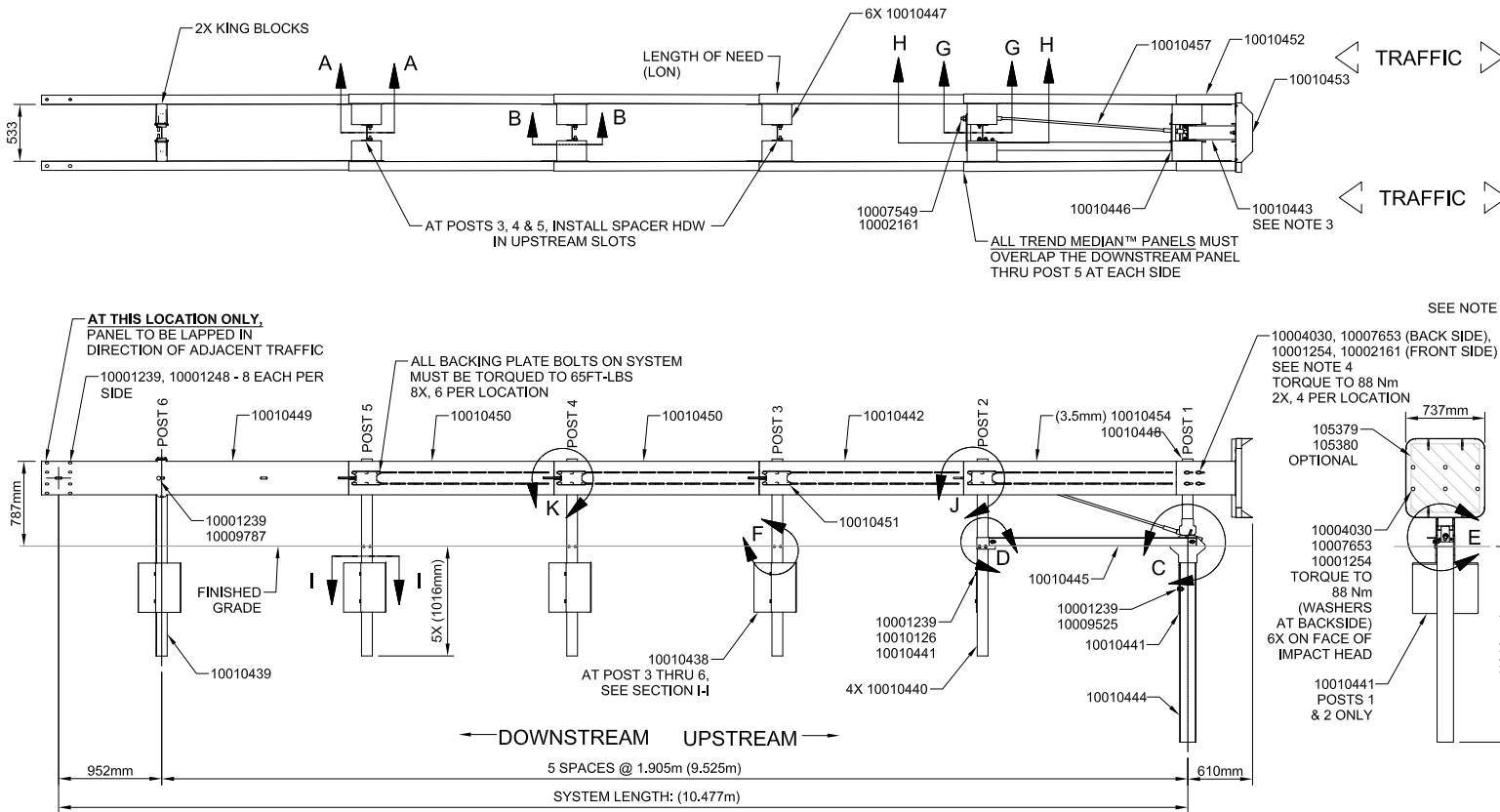

PARTS LIST		
PART NO.	DESCRIPTION	QTY.
10010444	CR POST #1 BOTTOM	1
10010440	1.83m POST/W6X8.5/7/S PL/SYT	4
10010448	TREND MEDIAN CR POST #1 TOP	1
10010446	TREND MEDIAN DOUBLE SPACER	2
10010447	TREND MEDIAN SINGLE SPACER	6
10010445	TREND MEDIAN ANGLE STRUT	1
10001239	M16 GR OVERSIZE HEX NUT	36
10010456	CRP-CBL BRKT FOR CRP PST	1
10010457	2,286m ANCHOR CABLE	1
10007549	1" HEX NUT A563	2
10010449	2,7mm BMT TRANS,W FIN-4	2
10010450	2,7mm BMT INT,W FIN-3	4
10010442	2,7mm BMT,W/O FIN-2	2
10010443	TREND MEDIAN IMPACT HEAD	1
10010443	TREND MEDIAN HEAD TUBE	1
10010452	TREND MEDIAN 3.4mm HEAD RAIL	2
10010451	TREND MEDIAN BACKING PLATE	8
10004030	M16 X 50 POST BOLT G8.8	62
10007653	M16 X 6mm THICK WASHER	62
10001254	M16 Nut CL8	66
10001248	M16 x 32 SPLICE BOLT G8.8	16
10009525	HEX BOLT M16 x 45 G8.8	6
10010125	M8 x 45 HEX BOLT G8.8	2
10001305	M8 FLAT WASHER	2
10009443	M8 HEX NUT CL8	2
10010455	STRUT ADAPTER PLATE	1
10010454	3.4mm FRONT RAIL,W/O FIN-1	2
10002161	1" ROUND WASHER F436	10
10009527	M16 ROUND WASHER	8
10004062	HEX BOLT M16 x 50 G8.8	6
10010439	1.83m POST/W6X8.5/7/S PL	1
10009787	M16 x 250mm TERMINAL BOLT	2
10010126	M16 x 90 HEX BOLT G8.8	10
10010441	6 x 457 x 610mm SOIL PL/4 H	2
10010438	6 x 380 x 430 SOIL PL/MULT	4
10001727	M12 ROUND WASHER	8
10001727	M12 HEX NUT	4
10001727	M12 X 45 HEX BOLT	4
10001397	KING BLOCK	2
SEE TABLE	OPTIONAL DELINEATION	REF

- NOTES:
1. PROPER SITE GRADING MUST BE ACCOMPLISHED BEFORE ASSEMBLY AND IN ACCORDANCE WITH STATE/SPECIFYING AGENCY GUIDELINES AND/OR THE AASHTO ROADSIDE DESIGN GUIDE.
 2. GUARDRAIL INSTALLATION HEIGHT TO BE 787mm (+25/-0) ABOVE FINISHED GRADE.
 3. PRIOR TO TIGHTENING HARDWARE PUSH IMPACT HEAD UNTIL P/N 10010443 TOUCHES UPPER PORTION OF POST 1.
 4. ENSURE 10002161 IS APPROXIMATELY CENTERED WITH P/N 10004030 PRIOR TO TIGHTENING.
 5. THE INTEGRATED FINS IN THE PROVIDED TREND MEDIAN™ GUARDRAIL PANELS ARE ALWAYS POSITIONED UPSTREAM.
 6. UNDER NO CIRCUMSTANCES SHALL THE GUARDRAIL PANELS WITHIN THE TREND MEDIAN™ BE CURVED OR RADIUSUED.
 7. ALL 62 LOCATIONS OF 10004030 MUST BE TORQUUED TO 88Nm.
 8. ALL FASTENERS NOT REQUIRED TO BE TORQUUED SHALL BE TIGHTENED TO A SNUG POSITION WITH A MINIMUM OF 2 BOLT THREADS PROTRUDING BEYOND THE NUT.

TABLE	
PART NO.	DESCRIPTION
105379	REF 25X25 BLK/YEL MEDIAN
105380	REFL 25X25 BLK/YEL GORE

REV	DATE	DESCRIPTION	DRAWN	CHECKED	APPROVED	DRAWING NUMBER	REFERENCE DRAWINGS	NAME	DATE	PROJECT	TITLE	INGAL CIVIL PRODUCTS PART No.	DRAWING No.
1	21-07-2023	PART NUMBER UPDATE	LG	JKZ	LG						TREND MEDIAN ASSEMBLY DETAIL SHEET 1 OF 2		TR-MED-001-1

INGAL CIVIL PRODUCTS
A valmont COMPANY

DRAWING AND CONTENTS ARE COPYRIGHTED TO INGAL CIVIL PRODUCTS AND CAN ONLY BE USED WITH PRIOR WRITTEN CONSENT FROM INGAL CIVIL PRODUCTS

57-65 AIRDS ROAD MINTO, N.S.W. 2566 PH. +61 2 9827 3333 www.ingalcivil.com.au

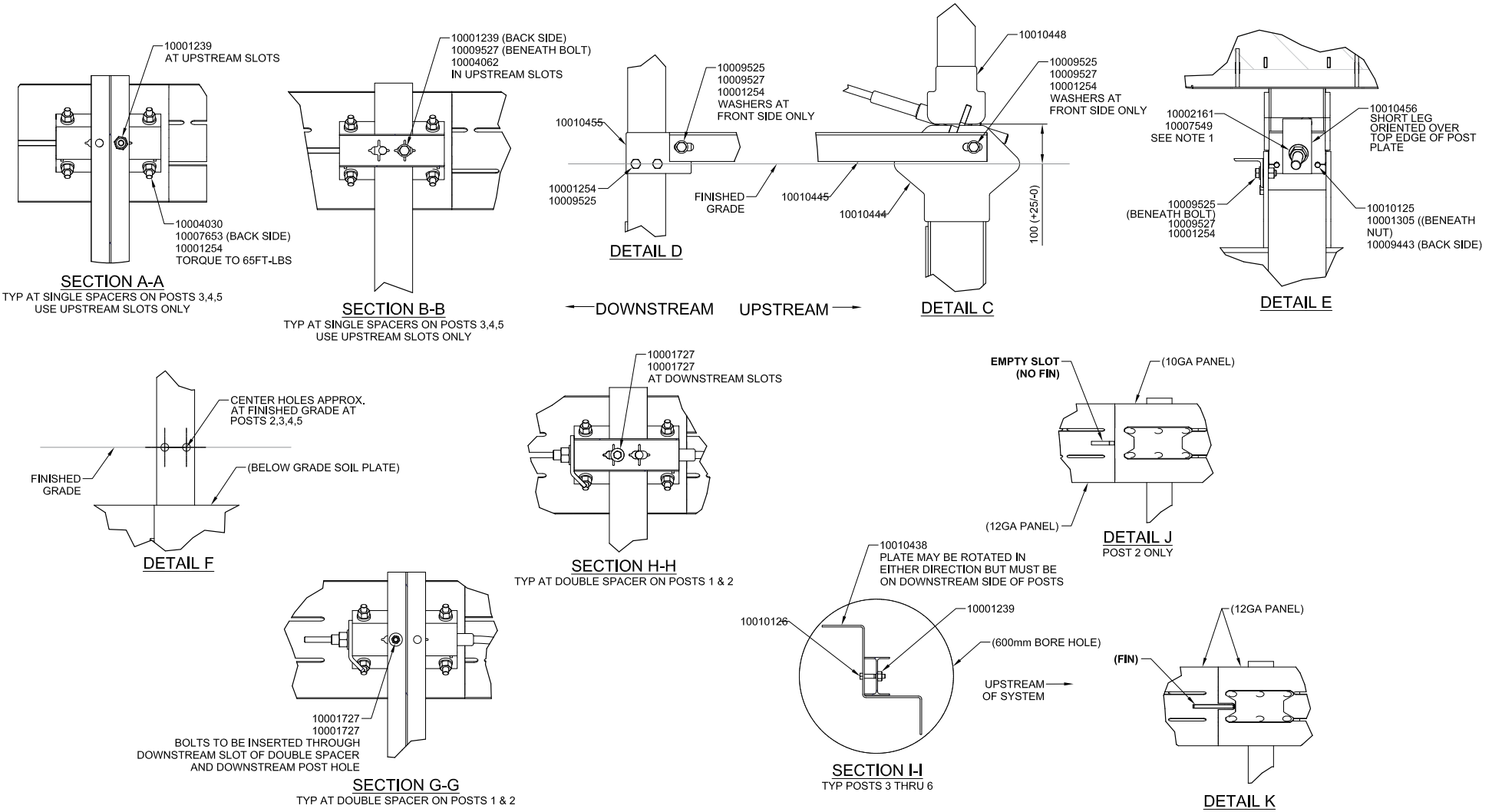

- NOTES:**
- TIGHTEN CABLE UNTIL TAUT. CABLE IS CONSIDERED TAUT WHEN IT DOES NOT DEFLECT MORE THAN 25mm WHEN PRESSURE IS APPLIED BY HAND IN AN UP AND DOWN DIRECTION. RESTRAIN THE CABLE WITH PIPE WRENCH OR LOCKING PLIERS WHILE TIGHTENING NUT WITH A WRENCH TO PREVENT CABLE FROM TWISTING.
 - GUARDRAIL INSTALLATION HEIGHT TO BE 787mm ABOVE FINISHED GRADE, +25, -0.
 - REFER TO TREND MEDIAN ASSEMBLY MANUAL FOR ADDITIONAL DETAILS.

REVISIONS			REFERENCES			NAME	DATE		PROJECT	INGAL CIVIL PRODUCTS PART No.	
1	21-07-2023	PART NUMBER UPDATE	LG	KZ	LG	DRAWN	TRIN		16-02-2022	TREND MEDIAN ASSEMBLY DETAIL SHEET 2 OF 2	TR-MED-001-2
						CHECKED	LG		16-02-2022		
						APPROVED	LG		16-02-2022		
REV	DATE	DESCRIPTION	DRAWN	CHECKED	APPROVED	SCALE	N.T.S. @	A3			
						ISSUE FOR	INFORMATION ONLY		DRAWING No.		
						DRAWING AND CONTENTS ARE COPYRIGHT TO INGAL CIVIL PRODUCTS AND CAN ONLY BE USED WITH PRIOR WRITTEN CONSENT FROM INGAL CIVIL PRODUCTS 57-65 ARDS ROAD MINTO, N.S.W 2566 PH. +61 2 9827 3333 www.ingalcivil.com.au			DRAWING No. TR-MED-001-2		

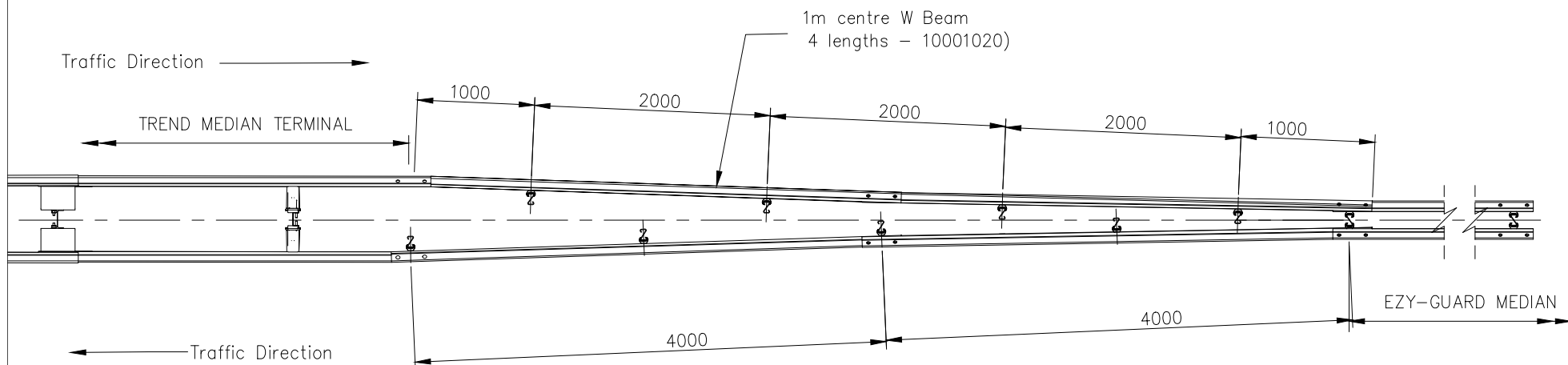
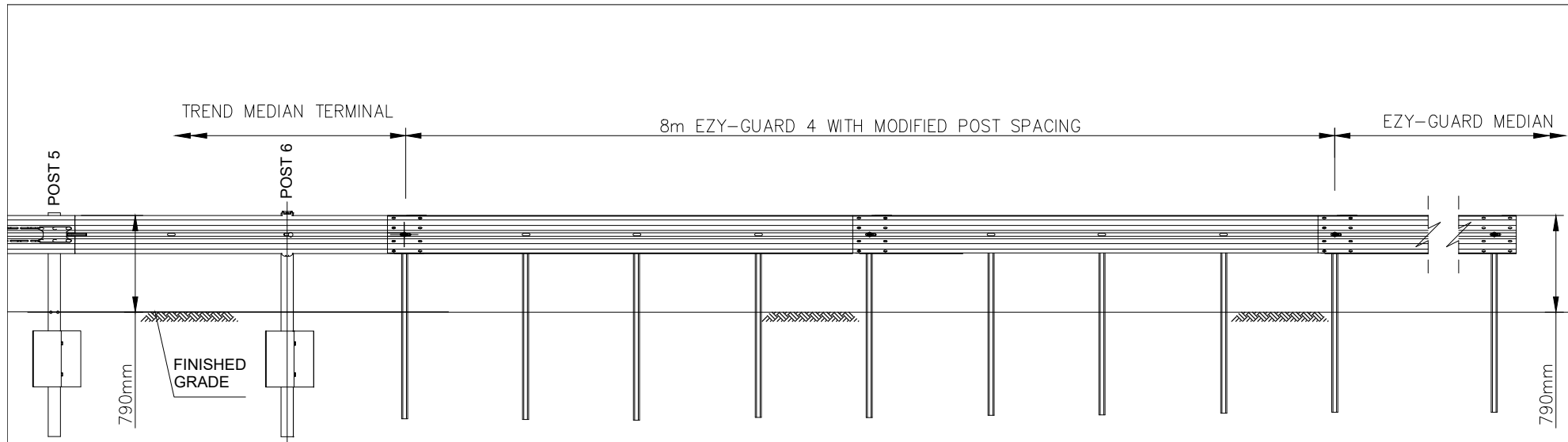

TO BE READ IN CONJUNCTION WITH THE TREND MEDIAN AND EZY-GUARD 4 PRODUCT MANUALS.

REVISIONS			REFERENCES			DRAWING INFORMATION			INGAL CIVIL PRODUCTS					
REV	DATE	DESCRIPTION	DRAWN	CHECKED	APPROVED	DRAWING NUMBER	REFERENCE DRAWINGS	ISSUE FOR	NAME	DATE	PROJECT	INGAL CIVIL PRODUCTS PART No.		
2	20-07-2023	UPDATED NOTES AND GRAPHICS	KZ	LG	LG				LG	17-02-2022				
1	25-10-2022	UPDATED THE POST POSITION	KZ	LG	LG				LB	18-02-2022				
									LG	18-02-2022				
									N.T.S. @ A3					
								INFORMATION ONLY						
									DRAWING AND CONTENTS ARE COPYRIGHT TO INGAL CIVIL PRODUCTS AND CAN ONLY BE USED WITH PRIOR WRITTEN CONSENT FROM INGAL CIVIL PRODUCTS 57-65 AIRDS ROAD MINTO, N.S.W. 2566 PH. +61 2 9827 3333 www.ingalcivil.com.au					
											TITLE	TREND MEDIAN TRANSITION TO EZY-GUARD 4	DRAWING No.	TR-MED-002
											PROJECT			Rev. 2

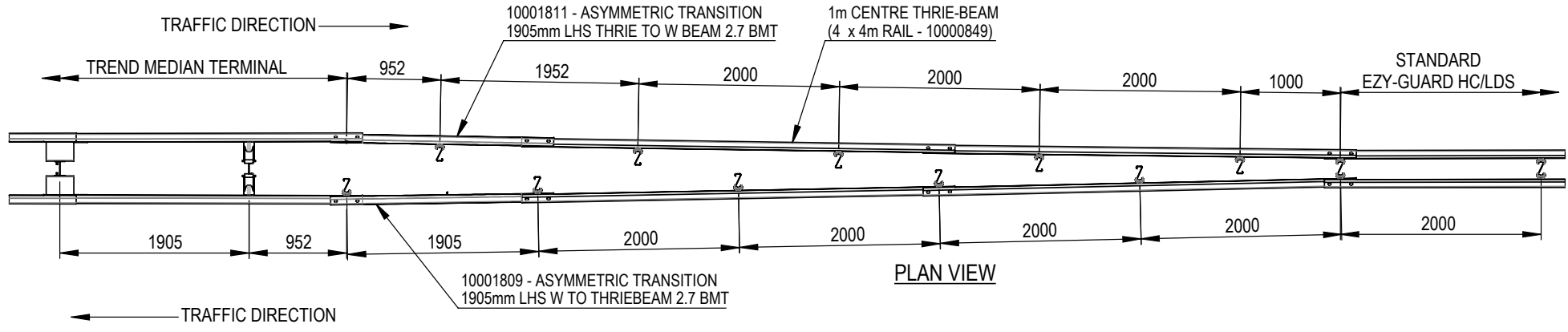

PLAN VIEW

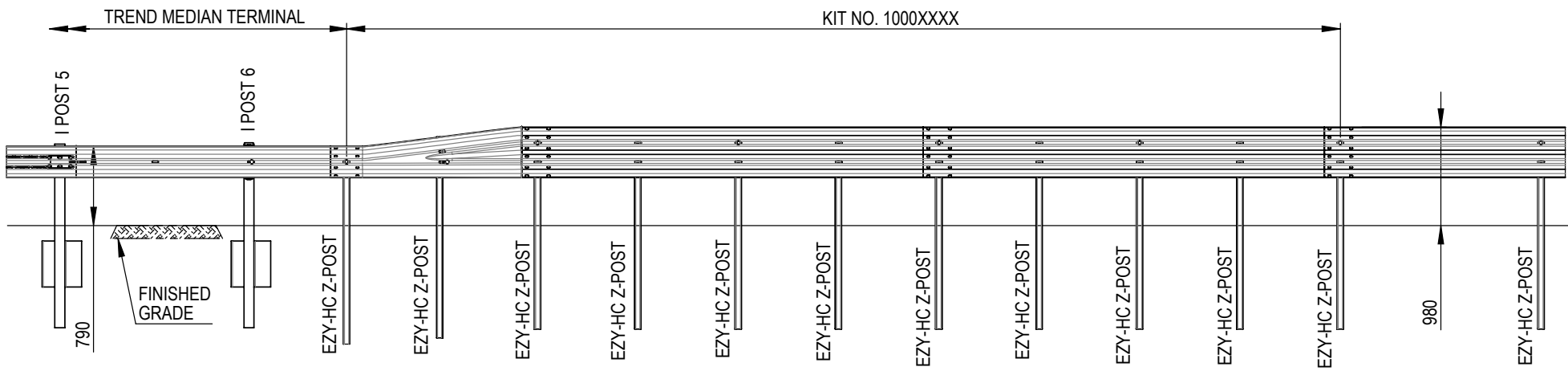

FRONT ELEVATION

TO BE READ IN CONJUNCTION WITH THE TREND MEDIAN AND EZY-GUARD HC PRODUCT MANUAL

REV.	DATE	DESCRIPTION	DRAWN	CHECKED	APPROVED	DRAWING NUMBER	REFERENCE DRAWINGS	NAME	DATE	PROJECT	INGAL CIVIL PRODUCTS PART No.
4	3/10/2023	UPDATED NOTES	KZ	LB	KZ			DRAWN	LG	18-02-2022	INGAL CIVIL PRODUCTS
3	20/07/2023	UPDATED POST DESCRIPTION	KZ	LG	LG			CHECKED	LB	18-02-2022	-
2	17/04/2023	UPDATED POST ARRANGEMENT	KZ	LG	LG			APPROVED	LG	18-02-2022	DRAWING No.
1	09/11/2022	UPDATED POST ARRANGEMENT	KZ	LG	LG			SCALE	1:55	SHEET: 1 of 1	TR-MED-003
								ISSUE FOR			Rev. 3



FOLDER: F:\ENGINEERING\SALES & MARKETING\DRAWINGS\TRENDS\TRENDS\MEDIANSOLIDWORKS\MODEL\TR-MED-003 - TRANSITION TO EZY-GUARD HC



For more information

contact us on the web

www.ingalcivil.com.au

Head Office: Sydney

57-65 Airds Road, Minto, NSW 2566

Ph: +61 2 9827 3333

Fax: +61 2 9827 3300

Free call (within Australia):

1800 803 795

Email: sales@ingalcivil.com.au

Our Locations:

• Adelaide • Brisbane

• Melbourne • Newcastle

• Perth • Sydney • Wagga

• Auckland • Christchurch