

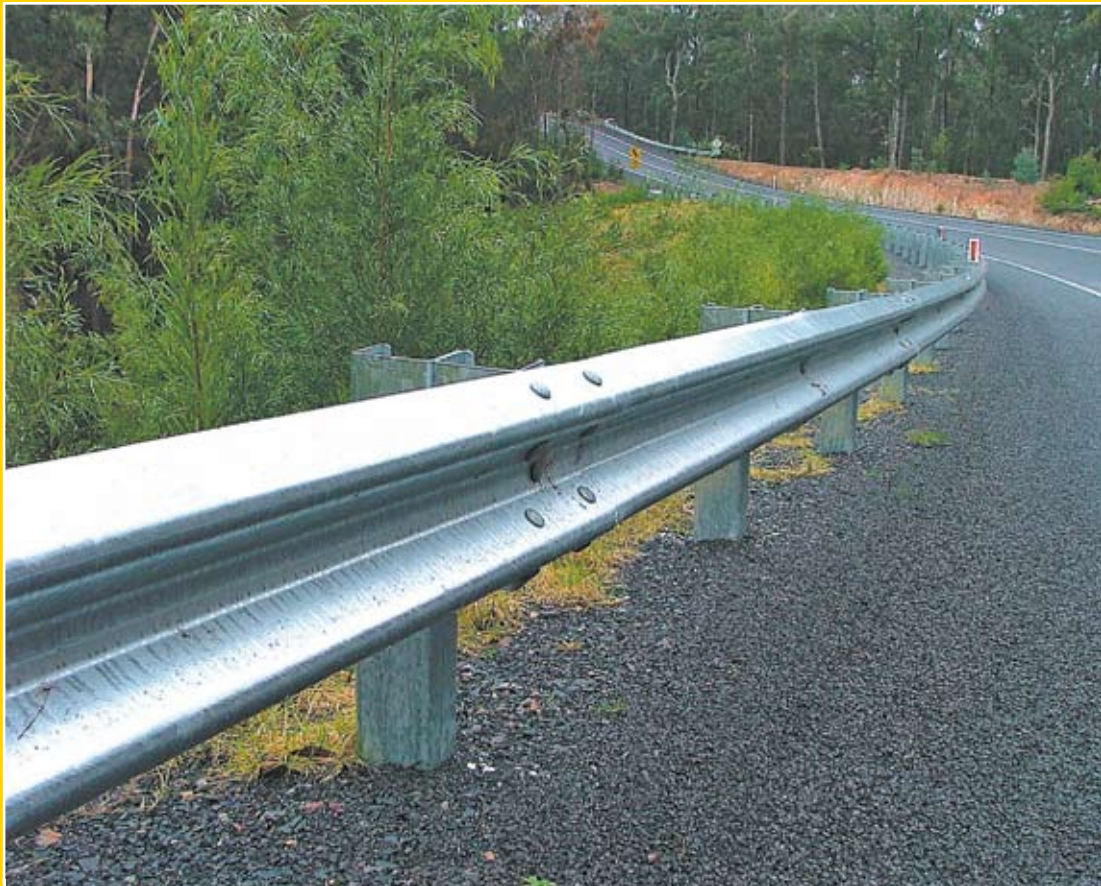

Flexbeam Guardrail

Roadside Safety Barrier

Product Manual



Release 04/21

www.ingalcivil.com.au

1.0 Introduction

Roadside barriers have been developed over the years to safely redirect vehicles that leave the roadway. Many different rigid, semi-rigid and flexible designs for roadside barriers have evolved. The most common system consists of a steel w-beam rail supported on steel posts with end treatments and transitions of various designs using similar materials.

Ingal Civil Products' Flexbeam guardrail's uniformly high resistance to impacts is assured by its continuous flexible beam action.

Please note, inline with the Austroads transition to MASH compliant systems, the G4, G9 and Type B safety barriers may no longer be approved for new installs in your jurisdiction, please consult your local Ingal representative for further information. For a fully compliant MASH TL3 guardrail barrier, please refer to our Ezy-Guard Smart W-Beam system.

2.0 Standards

Flexbeam guardrail is manufactured in accordance with the following;

- AS/NZS 3845:1999 Road safety barrier systems
- AS/NZS 4680:2006 Hot-dip galvanized (zinc) coatings

3.0 Specifications

Table 1: Flexbeam Panels - 2.7mm base metal thickness

Nett Laying Length (mm)	Ingal Part No.	Mass (kg)
1000	C1364G	14.1
2000	C1373G	25.0
2500	C1381G	30.5
3000	C1195G	36.0
3810 (12'6")	C1355G	44.6
4000	C1351G	46.7
5000	C1356G	57.6

Table 2: Charlie Posts 150 x 110 x 4.3mm

Post Length (mm)	Ingal Part No.	Mass (kg)
700 with Base Plate	C1432G	17.2
750 with Base Plate	C1409G	17.9
1800	C1402G	23.6
1850	C1415G	24.4
2100	C1444G	27.6
2400	C1458G	31.6

Table 3: U Channel Posts 178 x 76 x 6.0mm

Post Length (mm)	Ingal Part No.	Mass (kg)
700 with Base Plate	C1135G	17.0
1600	C1095G	23.3
1675	C1090G	24.4
1800	C1100G	26.3

4.0 Barrier Deflection

The expected deflection of the barrier should not exceed the available room to deflect. If the available space between the hazard and the barrier is not adequate, then the barrier can be stiffened in advance of, and alongside the hazard. Commonly used methods to reduce deflection of Flexbeam guardrail include reducing the post spacing, nesting the rail or transitioning to a stiffer barrier such as Thriebeam guardrail.

Design deflection values vary across jurisdiction, please refer to the local road authority guidelines and specifications for appropriate values.

G4/Type-B W-Beam and G9 Thrie-beam barriers are 'deemed to comply' to NCHRP-350 and the jurisdictional configuration may not be MASH compliant. For a MASH compliant solution, refer to the Ezy-Guard family of products.

5.0 Thriebeam Guardrail

An important attribute of Thriebeam guardrail is its high level of performance especially for large vehicles. Due to the greater height of the rail face, Thriebeam guardrail provides reduced deflection and improved resistance to vehicle vaulting or under running. The reduced dynamic deflection and maintenance demand makes Thriebeam guardrail ideally suited for major facilities carrying a high volume of high-speed traffic. Thriebeam guardrail should also be used in transition from Flexbeam guardrail to more rigid barriers. This significantly reduces the deflection of the barrier system at transition to the rigid barrier.

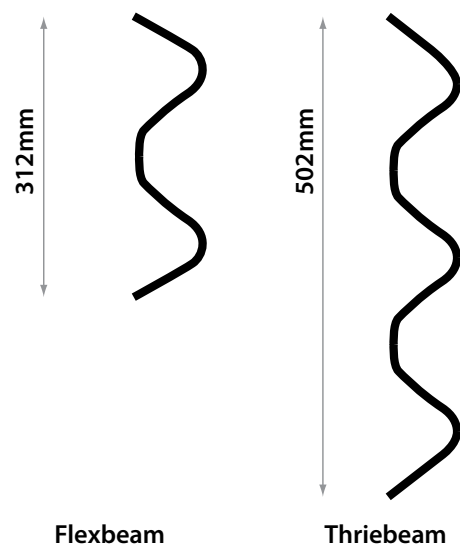

Figure 1: Flexbeam and Thriebeam Comparison

6.0 Installation

6.1 Site Preparation

Flexbeam guardrail should be located at least 600mm (measured from back of post) in front of embankments that require shielding. This distance is required to provide proper post support.

The approach terrain to the barrier must be level. Grading to 1:20 is preferable and 1:10 maximum slope should be present. Steeper slopes can result in the vehicle impacting the barrier at other than the design height.

6.2 Installation Sequence

The following written instructions should be read in conjunction with Ingal Civil Products' drawings:

1. Ensure the area has been inspected for underground hazards and that suitable traffic control is in place.
2. Post locations are marked ensuring the hazard to be protected is located outside the expected dynamic deflection of the barrier.
3. The post is orientated with no post edges presented towards the traffic.
4. Posts are driven directly into the ground and should be vertical. (The post installation process shall not cause damage to the post, such that it reduces the effective operation of the safety barrier or its design life, or introduces sharp tearing edges, nor shall it cause damage to pavement). Alternately, a hole can be augured and the post placed in the hole. The posthole is then backfilled with the material that was excavated. Material should be placed in layers and suitably compacted to not less than the density of the surrounding layers.
5. Blocking pieces are then attached to the posts using M16 hex. head bolts. The function of the blocking piece is to prevent wheel snagging and vehicle vaulting.
6. Rails are attached to the blocking pieces and are spliced using mushroom head bolts. The holes in the rails for attachment to the blocking pieces are slotted to allow for tolerances in post spacing.
7. Rails are spliced together at every second post using M16x32mm mushroom head bolts. Rails are orientated so that no leading edges are presented to the traffic face. At post locations where there is not a rail splice, a stiffener piece is inserted behind the rail. Washers are NOT used.
8. It is recommended that posts be installed only a few metres ahead of rail assembly to ensure correct post spacing and alignment. On curves, the rails can be used as a template and laid on the ground to determine post locations.



Figure 2: Attachment of steel blocking piece

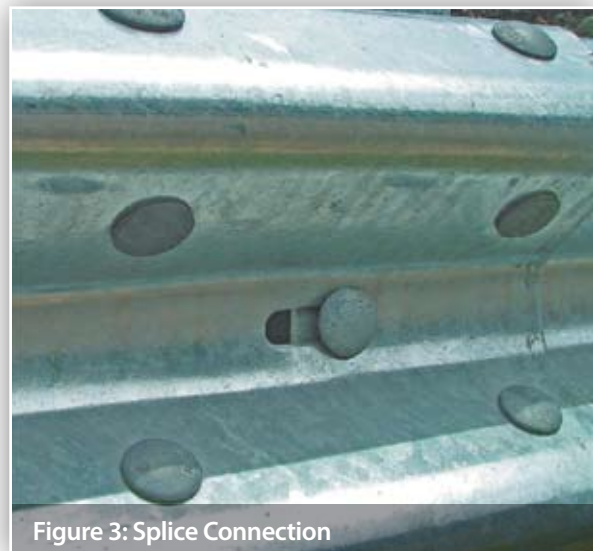

Figure 3: Splice Connection



Figure 4: Delineator

6.3 Curving

Flexbeam guardrail may be shop curved to fit any radius from 2.4m to 46m. Curves in excess of 46m radii do not require shop curving as the lap joint accommodates itself to such installations. Rail may be curved either concave or convex to the traffic face and can be part curved along its length to suit your needs.

6.3.1 Measuring Curvature

1. Depending on your length of rail, mark along your arc at 4m or 5m intervals
2. Measure the corresponding chord length (C) – Refer to Figure 5
3. Measure the corresponding centre offset (H) – Refer to Figure 5
4. Use the values for C and H to select the radius from Table 4
5. Determine the curvature orientation from Figure 6

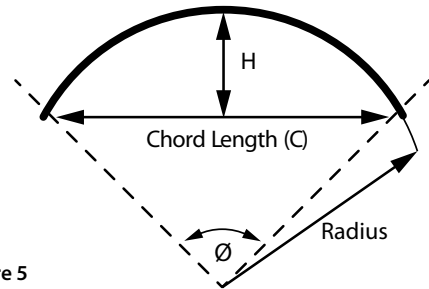

Figure 5

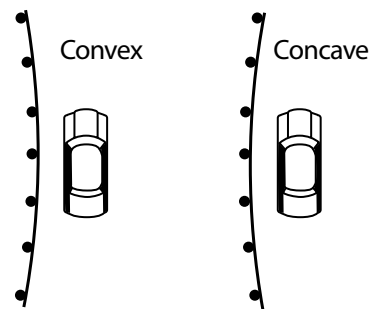

Figure 6

Table 4: Radius of Curvature

4000mm Rail				5000mm Rail		
Radius m	Ø Degrees	C mm	H mm	Ø Degrees	C mm	H mm
2.4	95.5	3553	786	119.4	4144	1189
3	76.4	3710	642	95.5	4441	983
4	57.3	3835	490	71.6	4681	756
5	45.8	3894	395	57.3	4794	612
6	38.2	3926	330	47.8	4857	513
7	32.7	3946	284	40.9	4894	442
8	28.7	3958	249	35.8	4919	387
9	25.5	3967	221	31.8	4936	345
10	22.9	3973	199	28.7	4948	311
12	19.1	3982	166	23.9	4964	259
14	16.4	3986	143	20.5	4973	223
16	14.7	3990	125	17.9	4980	195
20	11.5	3993	100	14.3	4987	156
24	9.6	3995	83	11.9	4991	130
28	8.2	3997	71	10.2	4993	112
32	7.2	3997	62	8.9	4995	98
35	6.6	3998	57	8.2	4996	89
40	5.7	3998	50	7.2	4997	78
45	5.1	3999	44	6.4	4997	69

7.0 End Terminals and Transitions

Guardrail end terminals are designed to provide a soft gating impact to prevent the end rail from spearing an impacting vehicle. Terminals also anchor the rail to provide the tensile strength necessary to ensure redirection performance of the length-of-need section.

Transitions are required when Flexbeam guardrail is terminated at a bridge abutment or a concrete parapet.

8.0 Product Storage

All posts and rails are hot dip galvanized in accordance with AS/NZS 4680. It is important that stored galvanized work is stacked so that each item is well ventilated and can adequately drain rainwater from its surfaces.

Poor storage can give rise to wet storage stain (white rust) which is caused by water (rain or condensation) in badly drained or ventilated conditions. This can occur very quickly, particularly in warm, humid conditions.



Figure 7: ET2000 Plus

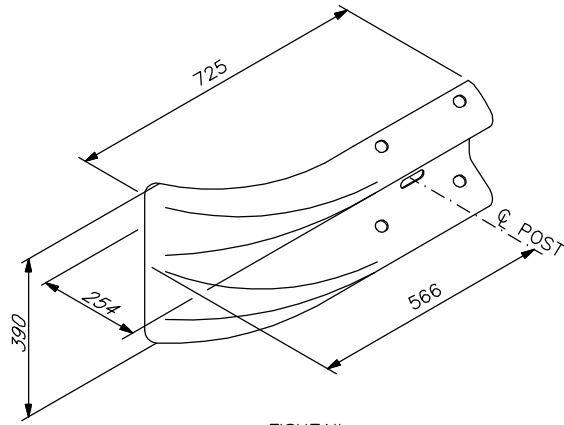

FISHTAIL
Part No. C1050G

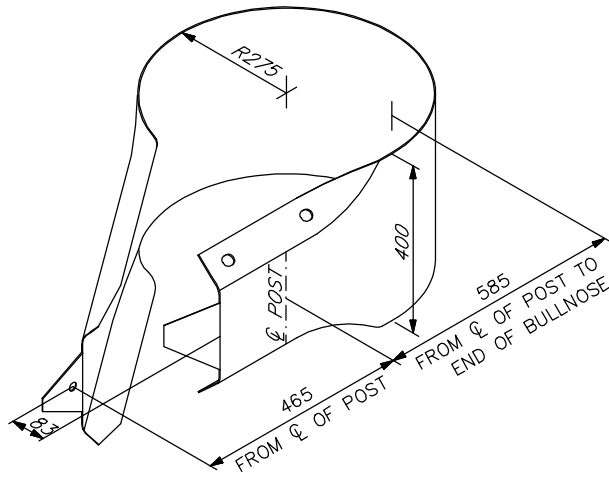

BULLNOSE
Part No. C1060G

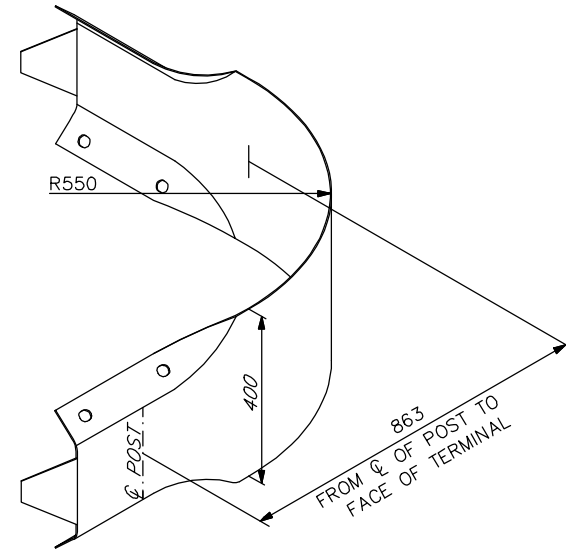

RIGHT ANGLE TERMINAL
Part No. C1068G

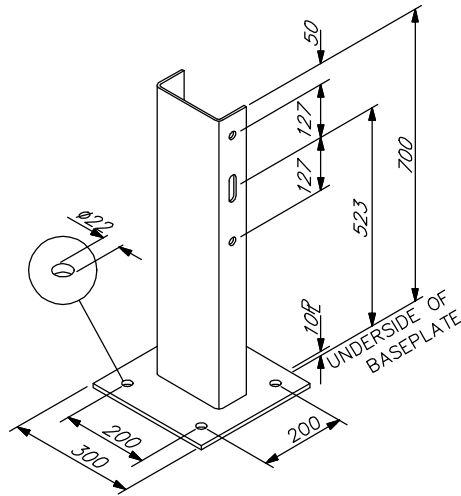

'U' POST ON BASE PLATE (VIC.)
Part No. C1135G

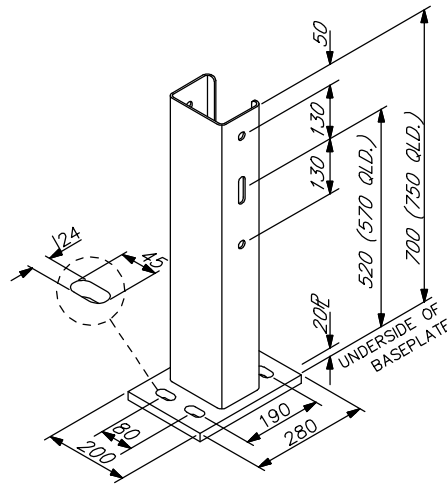

'C' POST ON BASE PLATE
Part No. C1432G
Part No. C1409G (QLD.)

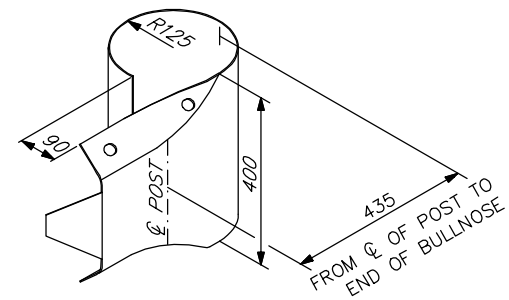

SHORT BULLNOSE
Part No. C1064G

Rev	Description	Chkd	Date
A	TITLE BLOCK UPDATED	MS	17/03/09
0	INITIAL ISSUE	T.C	30/01/06

INGAL Civil Products
 57-65 Airlds Road, Minto, NSW, 2566 Australia
 Telephone 61-2-9827 3333, Facsimile 61-2-9827 3300, Internet www.ingalcivil.com.au
 c Industrial Galvanizers Corporation Pty Ltd ACN 000 545 415 (2005)

This drawing is the subject of COPYRIGHT. No part of it may be used, reproduced or copied by any means or in any form without the prior permission of the owner.

PROJECT	FLEXBEAM GUARDRAIL ACCESSORIES
TITLE	COMPONENT DETAILS

DATE	30/01/06	INGAL CIVIL PRODUCTS
DRAWN	B.F	REFERENCE No.
DESIGNED		
CHECKED	T.C	
MATERIAL		DRAWING No.
FINISH	H.D GALV	GR—STD—049
SCALE	N.T.S	REV.A

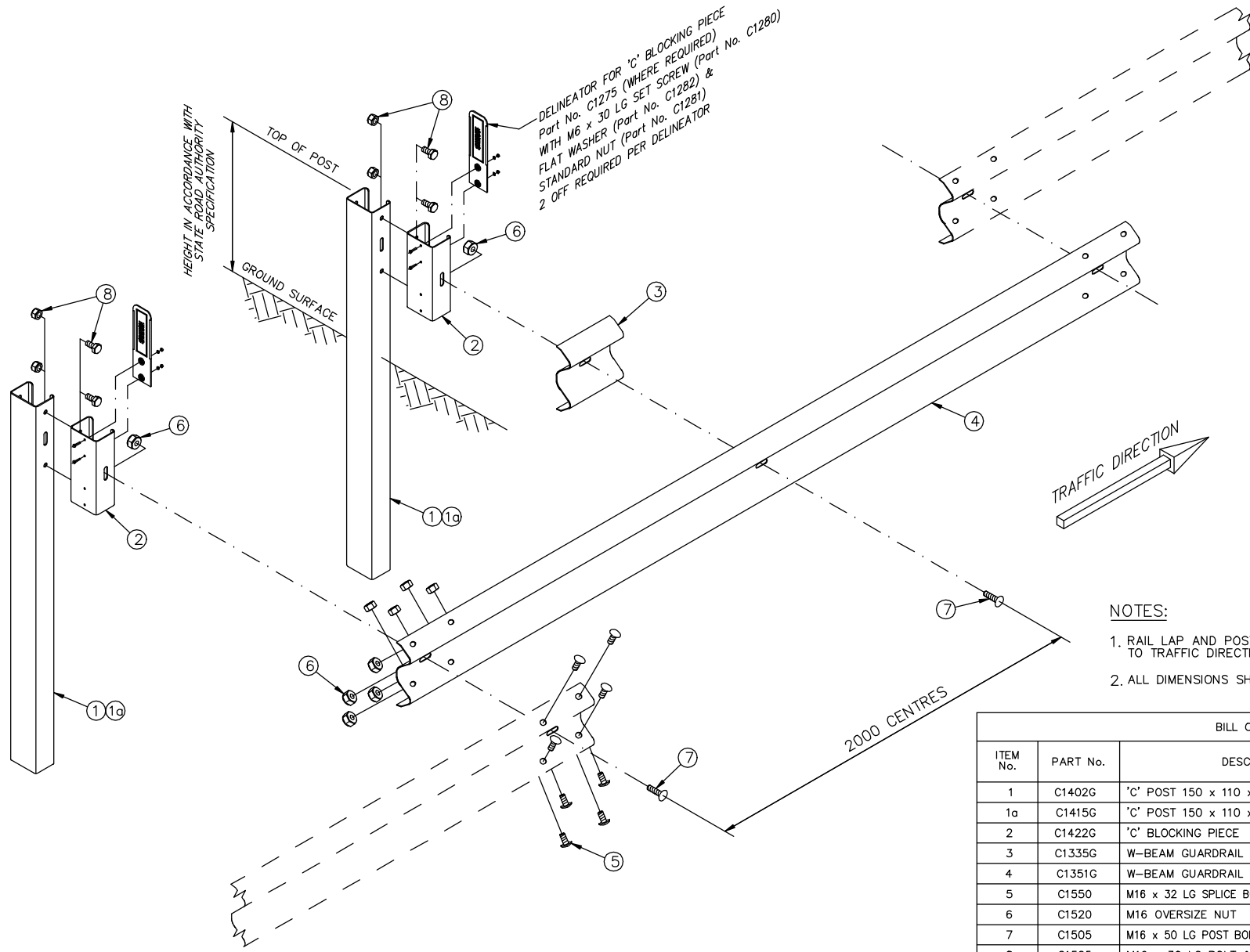

- NOTES:**
1. RAIL LAP AND POST ORIENTATION IN RELATION TO TRAFFIC DIRECTION AS SHOWN IS ESSENTIAL.
 2. ALL DIMENSIONS SHOWN ARE IN MILLIMETRES.

BILL OF MATERIALS			
ITEM No.	PART No.	DESCRIPTION	QTY
1	C1402G	'C' POST 150 x 110 x 1800 LG	2
1a	C1415G	'C' POST 150 x 110 x 1850 LG (QLD. STATE ONLY)	2
2	C1422G	'C' BLOCKING PIECE	2
3	C1335G	W-BEAM GUARDRAIL STIFFENER	1
4	C1351G	W-BEAM GUARDRAIL 4m NET LAYING LENGTH	1
5	C1550	M16 x 32 LG SPLICE BOLT - MUSHROOM HD (GRADE 8.8)	8
6	C1520	M16 OVERSIZE NUT	10
7	C1505	M16 x 50 LG POST BOLT - MUSHROOM HD (GRADE 4.6)	2
8	C1525	M16 x 30 LG BOLT & NUT - HEX. HD	4

Rev	Description	Chkd	Date
A	TITLE BLOCK UPDATED	MS	17/03/09
0	INITIAL ISSUE	T.C.	15/11/05

INGAL Civil Products
 57-65 Airds Road, Minto, NSW, 2566 Australia
 Telephone 61-2-9827 3333, Facsimile 61-2-9827 3300, Internet www.ingalcivil.com.au
 c Industrial Galvanizers Corporation Pty Ltd ACN 000 545 415 (2005)
 This drawing is the subject of COPYRIGHT. No part of it may be used, reproduced or copied by any means or in any form without the prior permission of the owner.

PROJECT **AASHTO G4 W-BEAM ASSEMBLY WITH 'C' BLOCKER**
 TITLE **GENERAL ARRANGEMENT**

DATE 15/11/05
 DRAWN B.F.
 DESIGNED J.C.P.
 CHECKED T.C.
 MATERIAL AS SHOWN
 FINISH H.D GALV
 SCALE NTS

INGAL CIVIL PRODUCTS REFERENCE No.
 DRAWING No. **CAB-STD-071**
 REV.A

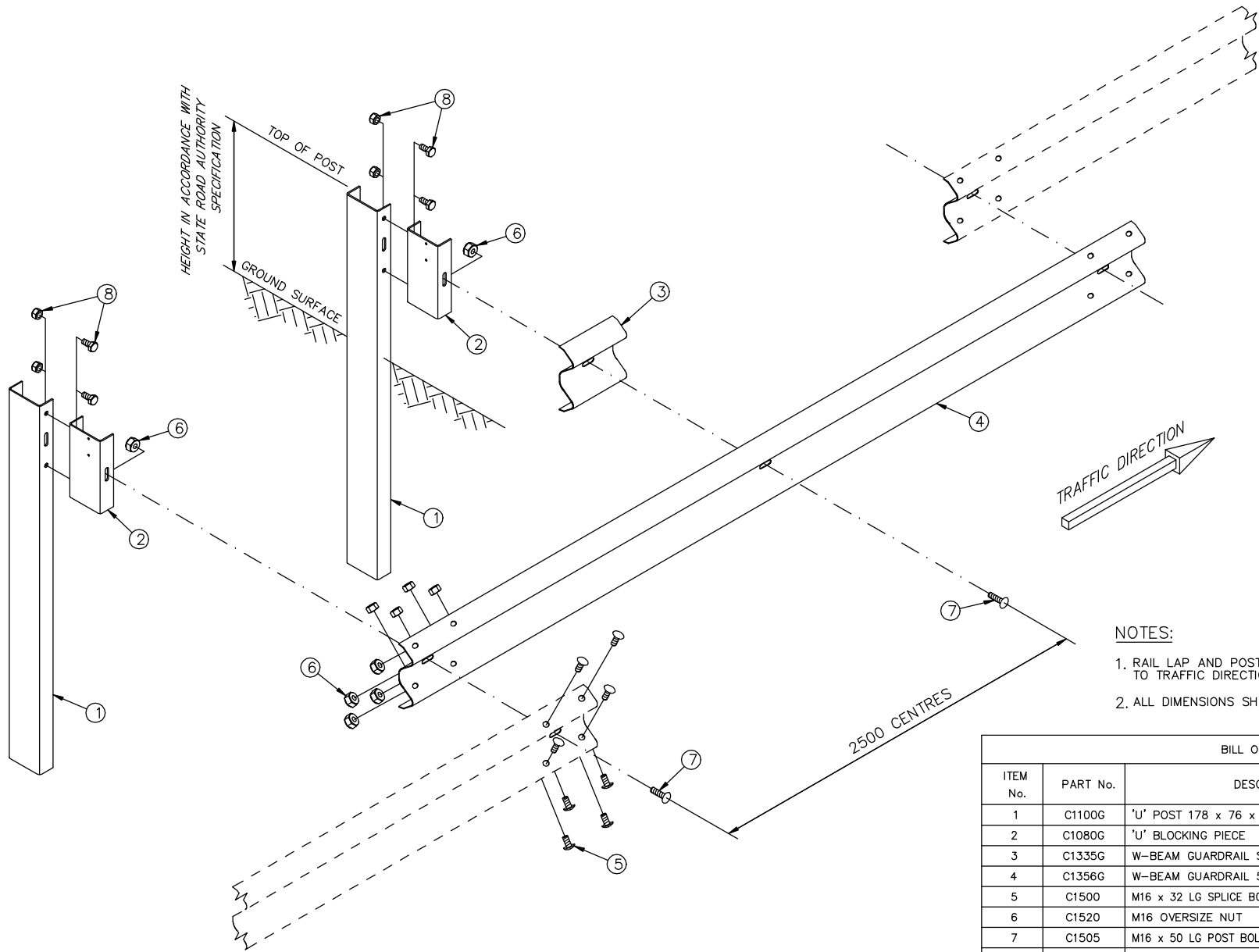

NOTES:

1. RAIL LAP AND POST ORIENTATION IN RELATION TO TRAFFIC DIRECTION AS SHOWN IS ESSENTIAL.
2. ALL DIMENSIONS SHOWN ARE IN MILLIMETRES.

BILL OF MATERIALS			
ITEM No.	PART No.	DESCRIPTION	QTY
1	C1100G	'U' POST 178 x 76 x 1800 LG	2
2	C1080G	'U' BLOCKING PIECE	2
3	C1335G	W-BEAM GUARDRAIL STIFFENER	1
4	C1356G	W-BEAM GUARDRAIL 5m NET LAYING LENGTH	1
5	C1500	M16 x 32 LG SPLICE BOLT - MUSHROOM HD (GRADE 4.6)	8
6	C1520	M16 OVERSIZE NUT	10
7	C1505	M16 x 50 LG POST BOLT - MUSHROOM HD (GRADE 4.6)	2
8	C1525	M16 x 30 LG BOLT & NUT - HEX. HD	4

Rev	Description	Chkd	Date
A	TITLE BLOCK UPDATED	MS	17/03/09
0	INITIAL ISSUE	B.F	15/11/05

INGAL Civil Products
 57-65 Airlds Road, Minto, NSW, 2566 Australia.
 Telephone 61-2-9827 3333, Facsimile 61-2-9827 3300, Internet www.ingalcivil.com.au
 c Industrial Galvanizers Corporation Pty Ltd ACN 000 545 415 (2005)
 This drawing is the subject of COPYRIGHT. No part of it may be used, reproduced or copied by any means or in any form without the prior permission of the owner.

PROJECT	VICTORIAN TYPE B GUARDFENCE
TITLE	GENERAL ARRANGEMENT

DATE	15/11/05	INGAL CIVIL PRODUCTS REFERENCE No.
DRAWN	B.F	
DESIGNED	T.C.P	DRAWING No. CAB-STD-072
CHECKED	T.C	
MATERIALS SHOWN		
FINISH	H.D GALV	
SCALE	N.T.S	REV.A

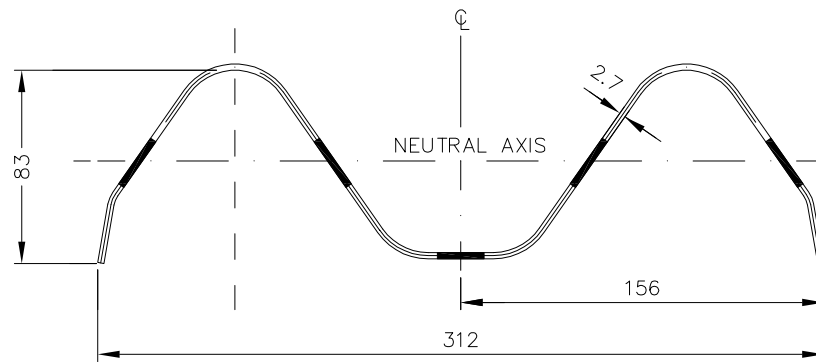
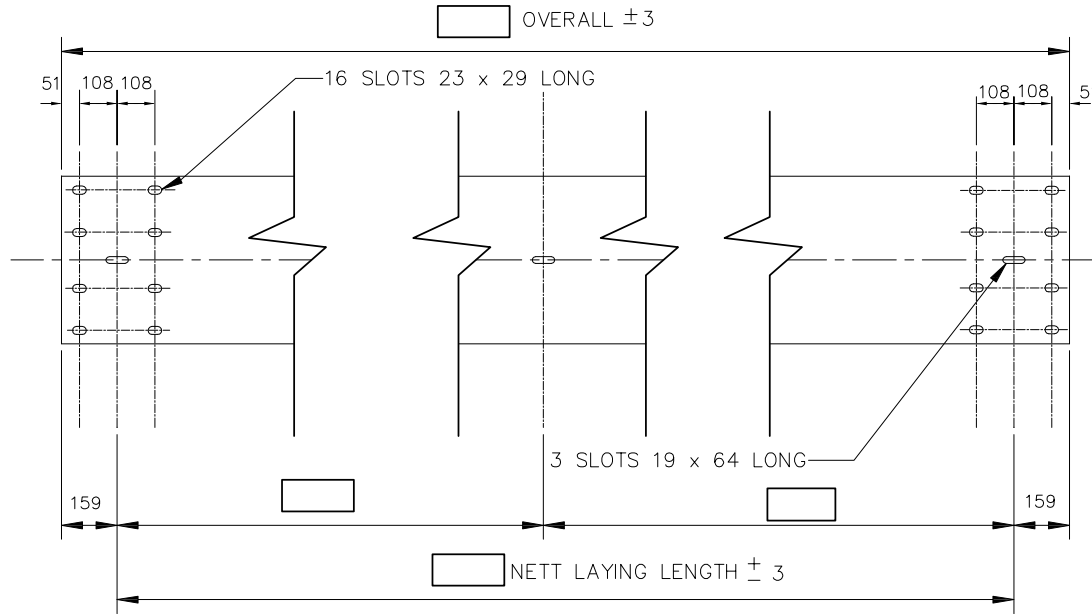

Material Specifications

1. Material shall satisfy the requirements of HA350 in accordance with AS1594
2. Tolerances on thickness, strip width and camber shall comply with AS1365
3. Material to be hot dip galvanized after fabrication in accordance with AS4680
4. Galvanized rails to be dichromate dipped as a final treatment immediately after galvanizing.

Rev	Description	Chkd	Date
2	TITLE BLOCK UPDATED	M.S	19/04/10
1	GALV. SPEC BORDER CHANGE		
0	INITIAL ISSUE	W.S-B	06/07/95

INGAL Civil Products

57-65 Airds Road, Minto, NSW, 2566 Australia
 Telephone 61-2-9827 3333, Facsimile 61-2-9827 3300, Internet www.ingalcivil.com.au
 © Industrial Galvanizers Corporation Pty Ltd ACN 000 545 415 (2005)

This drawing is the subject of COPYRIGHT. No part of it may be used, reproduced or copied by any means or in any form without the prior permission of the owner.

PROJECT	FLEX-BEAM GUARDRAIL SPECIAL RAIL
TITLE	TYPICAL DIMENTIONS AND MATERIAL SPECIFICATIONS

DATE	INGAL CIVIL PRODUCTS REFERENCE No.
DRAWN	
DESIGNED ICP	
CHECKED T.C.	
MATERIAL AS SHOWN	DRAWING No.
FINISH AS SHOWN	GR-STD-SPEC
SCALE N.T.S	REV.2

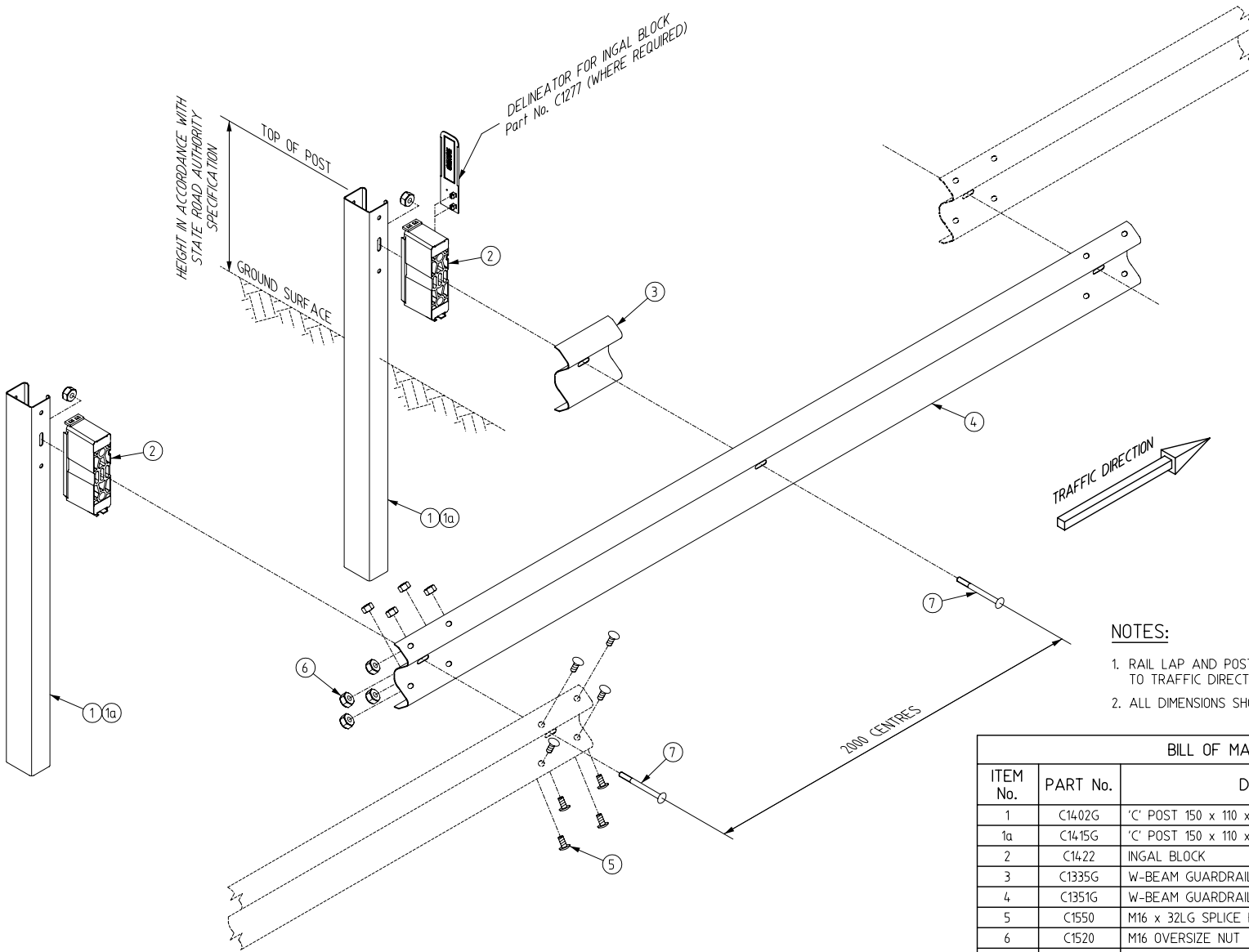

NOTES:

1. RAIL LAP AND POST ORIENTATION IN RELATION TO TRAFFIC DIRECTION AS SHOWN IS ESSENTIAL.
2. ALL DIMENSIONS SHOWN ARE IN MILLIMETRES.

BILL OF MATERIALS			
ITEM No.	PART No.	DESCRIPTION	QTY
1	C1402G	'C' POST 150 x 110 x 1800 LG	2
1a	C1415G	'C' POST 150 x 110 x 1850 LG (QLD. STATE ONLY)	2
2	C1422	INGAL BLOCK	2
3	C1335G	W-BEAM GUARDRAIL STIFFENER	1
4	C1351G	W-BEAM GUARDRAIL 4m NET LAYING LENGTH	1
5	C1550	M16 x 32LG SPLICE BOLT - MUSHROOM HD	8
6	C1520	M16 OVERSIZE NUT	10
7	C1508G	M16 x 200 LG POST BOLT - MUSHROOM HD	2

CAD FILE - CABSTD70.DGN 16/9/05

Rev.	Description	Chkd	Date
0	INITIAL ISSUE	T.C.	16/9/05

INGAL Civil Products
 127-141 Bath Road, Kirrawee, NSW, 2232 Australia
 Telephone 61-2-9710 5555, Facsimile 61-2-9542 3667, Internet www.ingalcivil.com.au
 © Industrial Galvanizers Corporation Pty Ltd ACN 000 545 415 (2005)
 This drawing is the subject of COPYRIGHT. No part of it may be used, reproduced or copied by any means or in any form without the prior permission of the owner.

NSW ACT QLD NT VIC TAS WA SA SNG HK ---

PROJECT **AASHTO G4 W-BEAM ASSEMBLY WITH INGAL BLOCK**

TITLE **GENERAL ARRANGEMENT**

DATE	16/9/05	INGAL CIVIL PRODUCTS REFERENCE No.
DRAWN	B.FREEMAN	
DESIGNED	I.C.P.	DRAWING No. CAB-STD-70 REV.0
CHECKED	T.C.	
MATERIAL	AS SHOWN	
FINISH	H.D.GALV.	
SCALE	N.T.S. (A3)	

THIS DRAWING IS TO BE READ IN CONJUNCTION WITH
 PRODUCTION DEPARTMENT INSPECTION SHEET CP-WI-05.5C/1.

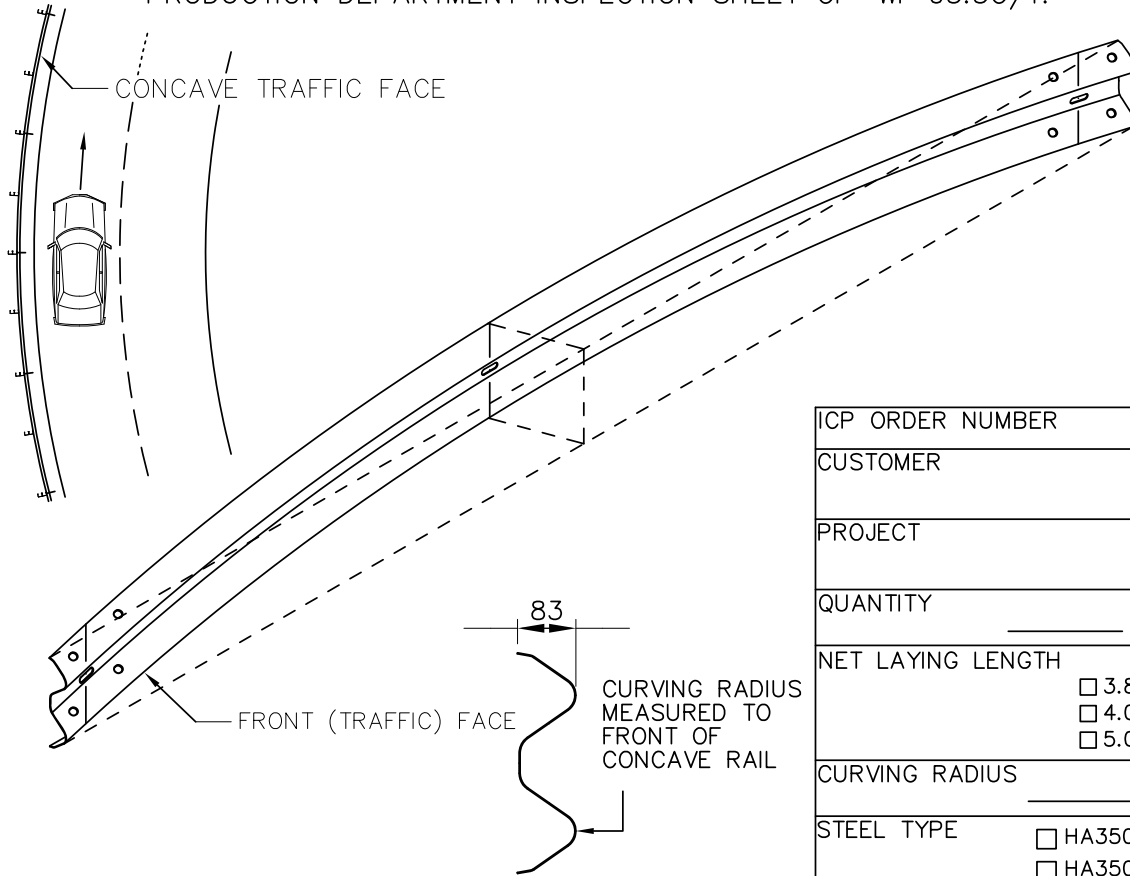

ICP ORDER NUMBER	
CUSTOMER	
PROJECT	
QUANTITY	PIECES
NET LAYING LENGTH	
<input type="checkbox"/> 3.81 METRES <input type="checkbox"/> 4.0 METRES <input type="checkbox"/> 5.0 METRES	
CURVING RADIUS	METRES
STEEL TYPE	
<input type="checkbox"/> HA350 2.7mm <input type="checkbox"/> HA350 3.5mm	

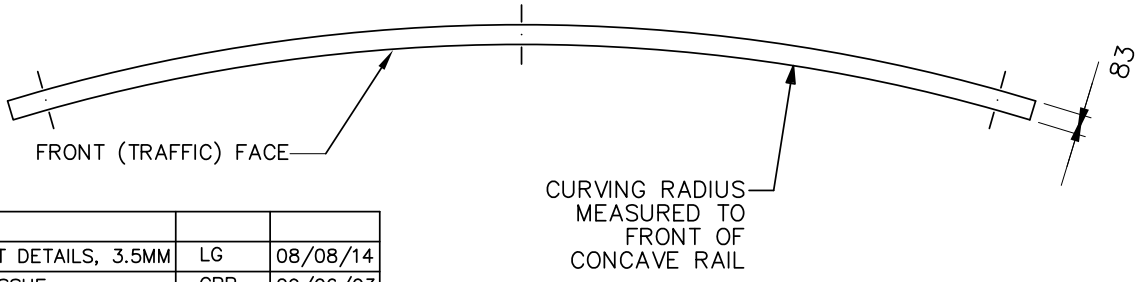
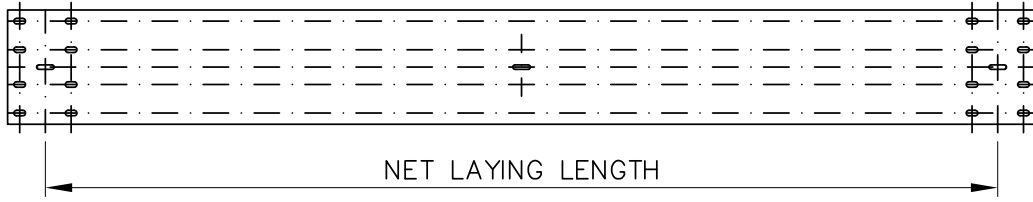

2	CONTACT DETAILS, 3.5MM	LG	08/08/14
1	INITIAL ISSUE	GPP	29/06/03
ISSUE	Description	Checked	Date

INGAL CIVIL PRODUCTS
 Civil Products
 57-65 Airds Road, Minto, 2566
 Australia
 Telephone 61-2-9710 5555
 Facsimile 61-2-9542 3667
 www.ingalcivil.com.au
 ©Industrial Galvanizers Corporation Pty. Ltd.

PROJECT DETAILS
**W-BEAM GUARDRAIL CURVING
 CONCAVE RAIL
 SINGLE CURVATURE**

DATE 29/06/03	DRAWN GPP	DESIGNED GPP	CHECKED GPP
MAT. HA350	FINISH H.D.GALV.	SCALE NTS	

INGAL CIVIL PRODUCTS
 DRAWING No.
GR-STD-30

ISSUE No.
2

This drawing is the subject of COPYRIGHT. No part of it may be used, reproduced or copied by any means or in any form without the prior permission of the owner.

THIS DRAWING IS TO BE READ IN CONJUNCTION WITH
 PRODUCTION DEPARTMENT INSPECTION SHEET CP-WI-05.5D/0.

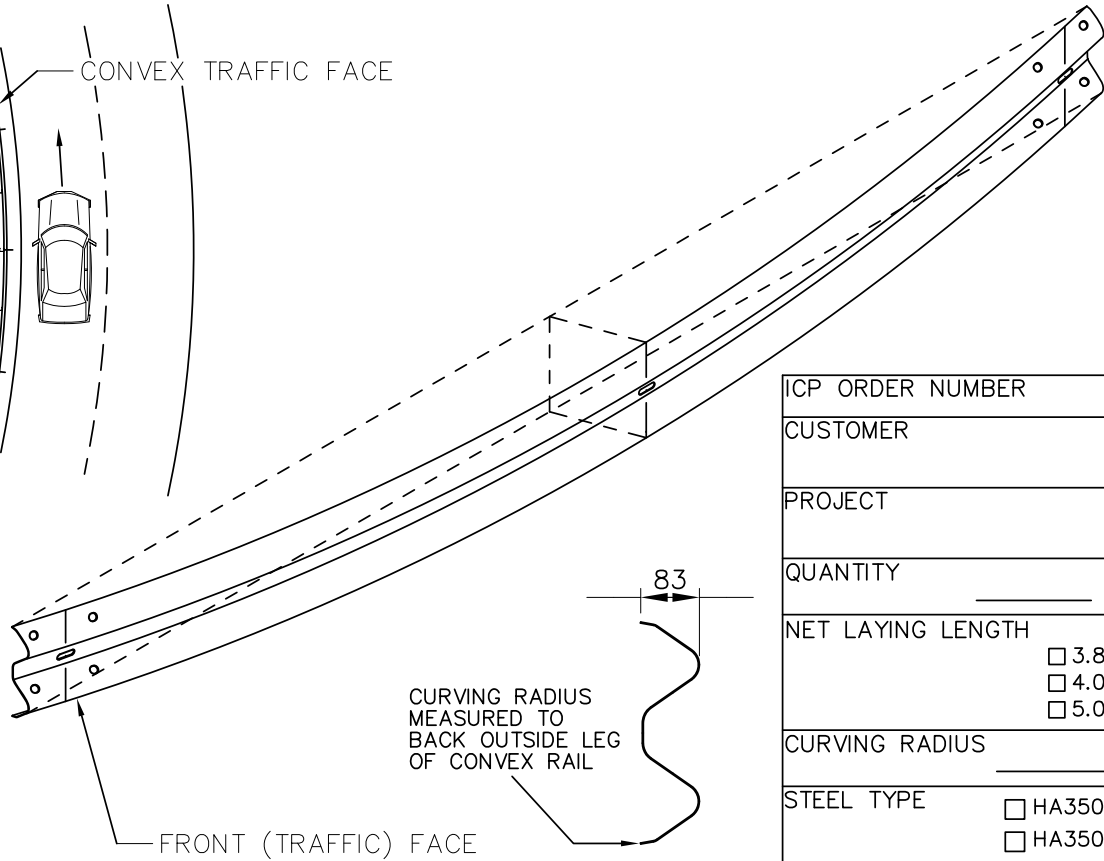
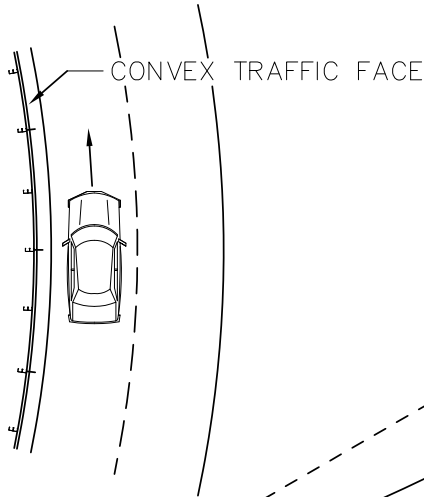

ICP ORDER NUMBER	
CUSTOMER	
PROJECT	
QUANTITY	PIECES
NET LAYING LENGTH	
<input type="checkbox"/> 3.81 METRES <input type="checkbox"/> 4.0 METRES <input type="checkbox"/> 5.0 METRES	
CURVING RADIUS	METRES
STEEL TYPE	
<input type="checkbox"/> HA350 2.7mm <input type="checkbox"/> HA350 3.5mm	

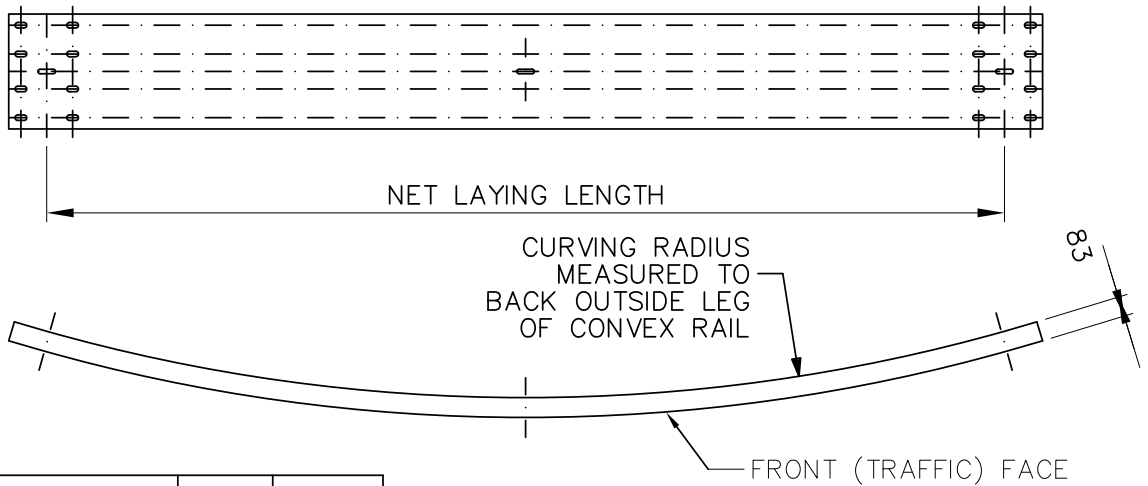

ISSUE	Description	Checked	Date
2	CONTACT DETAILS, 3.5MM	LG	08/08/14
1	INITIAL ISSUE	GPP	29/06/03

INGAL CIVIL PRODUCTS
 57-65 Airds Road, Minto, 2566
 Australia
 Telephone 61-2-9710 5555
 Facsimile 61-2-9542 3667
 www.ingalcivil.com.au
 ©Industrial Galvanizers Corporation Pty. Ltd.

PROJECT DETAILS
**W-BEAM GUARDRAIL CURVING
 CONVEX RAIL
 SINGLE CURVATURE**

INGAL CIVIL PRODUCTS
 DRAWING No.
GR-STD-31
 ISSUE No.
2

DATE 29/06/03	DRAWN GPP	DESIGNED GPP	CHECKED GPP
MAT. HA350	FINISH H.D.GALV.	SCALE NTS	

This drawing is the subject of COPYRIGHT. No part of it may be used, reproduced or copied by any means or in any form without the prior permission of the owner.



INGAL
CIVIL PRODUCTS
A valmont  COMPANY

For more information

contact us on the web

www.ingalcivil.com.au

Head Office: Sydney

57-65 Airds Road, Minto, NSW 2566

Ph: +61 2 9827 3333

Fax: +61 2 9827 3300

Local call (within Australia):

1300 446 425

Email: sales@ingalcivil.com.au

Our Locations:

• Adelaide • Brisbane

• Melbourne • Newcastle

• Perth • Sydney • Wagga

• Auckland • Christchurch