

Safence

Wire Rope Safety Barrier



Product Manual



Release 10/16

Safence is licensed to Ingal Civil Products by Blue Systems Inc. of Sweden

www.ingalcivil.co.nz

1.0 Introduction

The superior design and clean lines of Safence Wire Rope Safety Barrier (WRSB) has seen it become the road safety industry's preferred wire rope barrier. Safence has gained popularity as a median barrier for the prevention of crossmedian accidents. Cross-median accidents are typically violent collisions with a high probability of multiple serious injuries and death. Thus, the design trend is towards providing positive vehicle containment in wider median applications for which barriers have not historically been warranted.

The straight alignment of the ropes allows for easy installation and tensioning. Post footings are typically concrete with a sleeve to form a recess. Once the anchors and footings are poured, the ropes are cut to length, stainless steel end fittings are machine swaged and the ropes are tensioned.

2.0 Configurations

2.1 Safence TL3

Safence TL3 is a 4-rope barrier assessed in accordance with NCHRP Report 350 Test Level 3 (TL3). The TL3 heavy vehicle impact is performed with a 2,000kg pick-up truck travelling at 100km/h and 25°.

In addition, Safence TL3 has been evaluated to the requirements of containment classes N2 and H1 as per the European EN1317-2 specification. This requires impacts with a 10,000kg rigid truck travelling at 70km/h and 15° (H1) and a 1,500kg passenger car travelling at 110km/h and 20° (N2).

2.2 Safence TL4

Safence TL4 is available as a 3-rope or 4-rope barrier and has been assessed in accordance with NCHRP Report 350 Test Level 4 (TL4).

The TL4 configuration requires the addition of a post stiffener plate and top rope hook. All other components are identical to the TL3 configuration. The 3 rope configuration is achieved by removing the 2nd from bottom cable.

The TL4 heavy vehicle impacts are performed with a 2,000kg pick-up truck travelling at 100km/h and 25° and an 8,000kg rigid truck travelling at 80km/h and 15°.

3.0 Specification

Material:

Steel Wire Rope:	Mass – 1.21kg/m Ultimate Tensile Strength – 165.5kN
Sigma Posts:	Material to AS/NZS 1594
Anchor Bracket:	Material to AS/NZS 1594
Swage Fittings:	Stainless Steel, Grade 304
Plastic Parts:	UV Stabilised Polypropylene

Finish:

Steel Wire Rope:	Galvanised coating
Sigma Posts:	Galvanised to AS/NZS 4680
Anchor Bracket:	Galvanised to AS/NZS 4680

Dimensions:

Steel Wire Rope:	Right Hand Lay, 19.0mm Diameter 3x7 strands (1x3.15mm + 6x3.0mm)
Sigma Posts:	1230mm long

Cable Heights:

Top:	720mm
2nd from Top:	640mm
2nd from Bottom:	560mm (optional for Safence TL4)
Bottom:	480mm



Figure 1: Safence TL3

4.0 Technical Data

4.1 Safence Performance

Wire rope safety barriers are classified as flexible barriers and consideration must be given to the expected movement of the barrier when impacted.

The design of a WRSB should include an assessment of the mass of the impacting vehicle, its speed and angle of impact. Whilst rigorous crash testing is undertaken to evaluate the performance of roadside barriers, the deflection results obtained during testing should not be considered an exact distance, but rather as a single point within the range of deflections that can be expected.

4.2 Working Width

The working width is the maximum width that is required to prevent an impacting vehicle from colliding with an object behind a road safety barrier system. This includes the dynamic deflection and the extra width due to the roll of an impacting vehicle. The roll of a vehicle is an important consideration in shielding a fixed object hazard such as a utility pole or bridge support.

4.3 Dynamic Deflection

The dynamic deflection is defined as the largest transverse deflection of a road safety barrier system recorded during an actual crash or during a full-scale impact test.

If the available space between the hazard and the barrier is not adequate, then the barrier can be stiffened in advance of, and alongside the hazard by reducing the post spacing. Other factors that can have an influence on the deflection of the barrier include tension in the wire rope cables, horizontal curvature and installation length.

Safence crash test deflection results are listed on the Ingal drawings.

4.4 Footing Selection

Safence posts are supported by concrete footings containing a plastic sleeve. The footing provides lateral support to the post during impact ensuring the post yields by bending near ground level. The size of post footings is dependant upon the surrounding soil type and distance to the embankment rounding point.

Table 1 provides guidelines for the construction of post footings for varying site conditions.

Table 1: Post Footing Selection Guide

Centre of Post Footing to Rounding Point	Standard Soil		Weak Soil	
	Dia	Depth	Dia	Depth
Less than 0.5m	300	600	300	750
Greater than 0.5m	300	600	300	600

The minimum concrete compressive strength at 28 days is 25Mpa.

In the event that the soil type cannot be verified, then a post pull-over test can be conducted to validate the structural capacity of the footing.

A pull-over test is conducted by applying a load to the top of the post whilst positioned in the proposed footing design. The footing is required to remain stable until the post yields. Once the post yields, the footing has been subjected to its maximum potential load.

4.5 Minimum Length

The recommended minimum length-of need for a Safence installation is 40m.

4.6 Maximum Length

The recommended maximum run length of a Safence installation is 1200m.

4.7 Point-of-Need

Safence is designed to contain and redirect errant vehicles away from road side hazards. The location along the barrier system that redirection occurs is known as the point-of-need.

The point-of need for both the Safence TL3 and TL4 configurations is 12.6m from the anchor point when using the TL3 End Terminal.

5.0 End Terminals

End terminals are used to anchor the system and provide a soft gating impact to prevent vehicles from launching or snagging upon impact with Safence.

5.1 TL3 Terminal

The TL3 Terminal has been crash tested to meet the requirements of NCHRP Report 350 TL3. It can be used on all new installations or retrofitted to existing Safence installations.

The TL3 Terminal gradually tapers the cables from full height to an anchor bracket located at ground level.

The TL3 Terminal has demonstrated an ability to provide a soft, gating impact without releasing the cables from the anchor point. This non-release feature allows the system to remain anchored following design impacts.

This important feature contrasts terminals that are designed to release the cables for end-on impacts. Once these terminals release the cables their ability to provide continued containment and redirection for errant vehicles is compromised.

5.2 Standard Terminal

The Standard Terminal is designed to provide the necessary tensile support to redirect errant vehicles that impact the wire rope barrier within the length-of-need section.

5.3 TL3 Terminal - Workzone Applications

If used in a temporary workzone, the hazard free area is to be 30m from anchor point, with a width of 6m running parallel with the system.



Figure 2: TL3 End Terminal

6.0 Installation

The following written instructions should be read in conjunction with Ingal Civil Products' drawings.

A Safe Work Method Statement is available upon request to assist in the safe assembly of Safence.

Tooling and equipment is provided by Ingal for the installation of Safence. This equipment is known as the Safence Tension Unit and Safence Swaging Unit. Please contact your nearest Ingal representative for the safe operating instructions for this equipment.

6.1 Site Preparation

The approach terrain to the barrier should be level, otherwise a maximum grading of 1V:10H is permitted. Steeper slopes may result in the vehicle impacting the barrier at other than the design height.

6.2 Horizontal and Vertical Alignment Criteria

The installation of wire rope barriers on horizontal curves may increase the dynamic deflection of the barrier. In addition, horizontal curves may place more lateral load on the post foundations. To calculate the effect of a curve on the deflection, multiply the deflections as detailed on the system arrangement drawings by the curve correction factor in Table 2, these correction factors only apply to convex curves.

The minimum allowable sag vertical curve for wire rope barriers is $\geq 30\text{m}$. ($K = \text{length of VC in metres divided by the change in grade expressed as a percentage}$). There is no K value limit for crest curves.

Table 2: Curve Correction Factors

Length (m)	Convex Curve Radius (m)					
	200 - 400	400-600	600-800	800-1000	1000-1500	1500+
0-100	1.5	1.4	1.3	1.2	1.1	1.0
101-200	1.8	1.6	1.4	1.3	1.2	1.1
201-300	2.0	1.8	1.6	1.4	1.3	1.1
301-400	2.2	2.0	1.8	1.6	1.4	1.2
401-500	2.5	2.2	1.9	1.7	1.5	1.2
500+	2.5	2.2	2.0	1.8	1.5	1.2

6.3 End Anchor Site Preparation

The site should be inspected for the presence of underground utilities prior to any excavation. The site should be prepared free of obstructing vegetation and other hazards that may interfere with the installation or operational performance of the system. Some sites may require minor grading if installed beyond the edge of the pavement shoulder.

Vehicles impacting the end of the terminals will normally continue behind and beyond the barrier and may encounter non-traversable terrain or other roadside hazards. It is recommended that the guidelines as stated in AS/NZS 3845 for the installation of gating safety barrier end terminals be observed.

AS/NZS 3845 requires that a Hazard Free Zone immediately behind the terminal... should be reasonably traversable and free from fixed object hazards. If a clear runout is not possible, this area should be similar in character to adjacent unshielded roadside areas.

6.4 Construction of Anchor Blocks

Safence is available with a variety of anchor block designs. These include;

1. Rectangular
2. Trapezoidal
3. Pier

The selection of a suitable design will depend upon soil type, road formation width and available installation equipment.

Typically, the alignment of the anchor block will follow the same alignment as the length of need section. If site conditions require the anchor block to be offset to the length of need section, a 200m radius can be introduced upstream from the end anchor until the desired offset angle is achieved. The fence can then be tapered at a constant rate to achieve the required offset distance.

The construction sequence is as follows;

1. Excavate the anchor hole in accordance with Ingal drawings.
2. If installing the rectangular anchor block, clip out several grids of the reomesh square to fit over the anchor bracket as shown in Ingal drawing WR-STD-62.



Figure 3: Clipping of Reomesh

3. Attach 3 off M20 x 550mm hook bolts to the base of the anchor bracket using 2 off M20 nuts per hook bolt. One M20 nut is used either side of the anchor bracket to secure each hook bolt.
4. Using formwork, suspend the anchor bracket and reomesh, ensuring the anchor bracket levelling plate is at the same longitudinal grade as the roadway. The position of the anchor bracket is to be in accordance with Ingal drawings.



Figure 4: Placement of Anchor Bracket

5. To prevent flotation or dislodgement during the concrete pour, drive a shortened star picket into the base or side of the excavation and use tie wire to secure the bracket.
6. Pour concrete into the excavation and vibrate. Ensure that the anchor bracket has remained secure.
7. Trowel the surface of the anchor block and shape to provide fall way from the anchor bracket.



Figure 5: Trowelling of the Anchor Block

6.5 Construction of Post Footings

1. Establish post spacing in accordance with expected dynamic deflections and excavate postholes to the dimensions in accordance with Table 1. Note that the height of the footing must be within 20mm of the design reference height.
2. Pour concrete into each hole.
3. Insert the post footing reinforcement ring to a depth providing 50mm of cover.



Figure 6: Pouring of Concrete



Figure 7: Insertion of the Post Reo Ring

4. Insert the Safence post into the plastic HDPE sleeve.
5. Push the Safence post and the plastic HDPE sleeve into the wet concrete so that the top of the plastic sleeve is at ground level. The posts are orientated so that the smooth face is towards the traffic face.
6. Trowel the surface of the post footings and shape to provide fall away from the post sleeve.



Figure 8: Trowelling of the Post Footing

6.6 Assembly Sequence

1. It is recommended that concrete used for the construction of anchor blocks and post footings be cured for a period of 7 days prior to tensioning.
2. Slide the ground covers over each Safence post.
3. Starting at the leading or high end of the fence, connect the bottom wire rope to the anchor using a temporary anchor connection and run out the wire rope through the post slots to the far anchor and cut the rope to length. When a reel is depleted, attach the end to the next reel by tying the cables together and continue to run out the cable.
4. Insert the plastic spreaders into the post slots.
5. Repeat these procedures with subsequent wire ropes. Ensure the stainless frame is inserted between the top two ropes.
6. When all the ropes have been installed, fit the plastic caps to the posts.

6.7 Assembly Sequence – Safence TL4

The installation of Safence TL4 requires the following additional procedures;

1. When all the ropes have been installed, a rope hook is attached through the pre-punched holes in the top of the posts.

Note. Ensure steel rope spreaders are used in the first full height post of the Safence TL3 Terminal. Refer post (k) on drawing WR-STD-050.



Figure 9: Pre-welded stiffener plate



Figure 10: Attachment of Rope Hook



Figure 12: Securing of Fittings

6.8 Installation of Tension Bays

Tension bays are located at 300m centres and not more than 150m from either anchor point.
For fences less than 600m;

1. Swage the stainless steel end fittings onto all the cables and attach to the anchor bracket. The procedure for swaging is contained in the Safence Swaging Unit Safe Operating Procedure Manual. The bottom rope is located nearest to the approaching traffic face. Each end fitting is secured at the anchor with one washer and two nuts.

Note: An inspection hole is drilled into each stainless steel end fitting to ensure the wire rope cables are properly inserted into the end fittings before swaging.

2. Pull the slack out of the wire ropes toward the other anchor. This can be achieved by hand or by using a sling equipped with a lever claw clamp.



Figure 13: Attachment of Lever Claw Clamp



Figure 11: Anchor Block fitting arrangement

3. At locations where the wire rope reels have been temporarily joined, swage the end fittings onto the cables and install a tension fitting. End fittings should be positioned so that the end of the fitting is a minimum distance of 50mm from the post.
4. After the slack has been removed from the fence, machine swage the end fittings and attach to the trailing or low-end anchor.
5. Identify the tension bay location(s).
6. Mark and cut out an 800mm section from each cable. It may be necessary to attach temporary clamps one post back from the tension bay location prior to cutting in order to prevent the cables from retracting. End fittings should be positioned so that the end of the fitting is a minimum distance of 50mm from the post.



Figure 14: Attachment of Temporary Clamp

7. Swage the end fittings to each cable and attach the tension fittings. The procedure for swaging is contained in the Safence Swaging Unit Safe Operating Procedure Manual.
8. Attach the tensioning rig to the bottom cable and tension from the bottom up. The procedure for Tensioning is contained in the Safence Tension Unit Safe Operating Procedure Manual. Each rope is tensioned in accordance with Table 4.

For fences greater than 600m

1. Machine swage the cables at the leading or high-end anchor and attach to the anchor bracket.
2. Pull the slack out of the wire ropes towards the 1st tension bay location. This can be achieved by hand or by using a sling equipped with a lever claw clamp.
3. At the 1st tension bay location clamp the wire rope cable to a post. Repeat process for each cable, clamping each cable to a different post.
4. Cut the cables on the un-tensioned side of clamps and machine swage fittings. Assemble the tension fittings.
5. Relocate to the 2nd tension bay and repeat the above process. Continue until all the tension bays are completed.

6. Once the slack has been removed from the fence, swage the end fittings and attach to the trailing or low-end anchor.
7. Once the cables are attached at the anchor bracket, relocate to the centre tension bay.
8. Attach the tensioning rig and tension in accordance with Table 4 from the bottom up.
9. Relocate from the centre bay outwards repeating the tension process.
10. Once complete, relocate to the centre bay and repeat tensioning in this bay only.

Note: Upon completion of the installation the various tension bays shall not be more than 90% of their full extent so as to allow for further adjustment.

Table 3: Construction Tolerances

Description	Recommended Tolerance
Rope Height	± 20mm
Post Spacing	± 30mm
Post Footing Dimensions	- 10mm
Anchor Block Dimensions	- 20mm

Table 4: Tension Unit Pressure Requirements

Ambient Temperature °C	TL3 System (Bar)	TL4 System (Bar)
- 10	(26kN) 278	(38kN) 410
5	(24kN) 263	(36kN) 386
0	(23kN) 247	(34kN) 363
5	(21kN) 231	(32kN) 340
10	(20kN) 215	(29kN) 316
15	(18kN) 200	(27kN) 293
20	(17kN) 184	(25kN) 270
25	(16kN) 168	(23kN) 247
30	(14kN) 152	(21kN) 224
35	(13kN) 137	(19kN) 201
40	(11kN) 121	(17kN) 177

6.9 Clean-up and Waste Materials

Recycle, reuse or dispose of all surplus material, rubbish and other debris in accordance with the requirements of the local state based environmental protection specification.



Figure 15: Tension Bay

7.0 Safence Maintenance

Safence is a low maintenance roadside safety barrier. Except for repairs due to impacts, there is virtually no maintenance required for the system. It is recommended that regular drive-by inspections be performed to ensure the following;

1. Post caps have not dislodged. Delineation stickers are attached to the post caps and a loss of numerous caps could result in poor delineation.
2. Debris has not accumulated around the system. A clear zone, free of hazards should exist immediately behind the fence to accommodate for the expected dynamic deflection.
3. Ropes have not dislodged from the posts as a result of minor impacts.

7.1 Cable Tension

Safence is supplied with pre-stretched wire rope. The pre-stretching process removes the constructional stretch in the wires as they 'bed-down'. Wire rope is essentially an elastic member and will not require retensioning after most impacts. For fences subjected to regular vehicle impacts or large seasonal temperature variations, it may be necessary to evaluate the rope tension annually. This can be undertaken using the Safence Tension Unit.

7.2 Bush Fire Damage ¹

The performance of galvanized coatings when subjected to bushfire depends on a number of factors, such as flame duration, intensity and the characteristics of the galvanized coating and the technology with which it is applied.

Typical bushfire conditions may expose steel structures to air temperature of 800°C for periods of up to 120 seconds, however zinc coatings are generally reflective and will not absorb heat at the same rate as an uncoated steel surface. Depending on the section thickness of the steel, the actual steel surface temperatures may not exceed 350°C.

Typically, the bushfire flame duration and intensity are not high enough to compromise the structural strength of the steel. The hot dip galvanized coating will thus remain largely unaffected through a bushfire event. If the bushfire causes damage to the galvanized surface, then the item(s) shall be replaced.

7.3 Damage Assessment

In the event of a vehicle impact, damage to the barrier is to be assessed in accordance with Table 5. In the event that the ropes are to be cut, they are NOT to be cut under tension.

A Safe Work Method Statement is available upon request to assist in the safe repair of Safence.

¹Information based upon testing conducted on behalf of BlueScope Steel by the CSIRO Manufacturing and Infrastructure Technology Bushfire CRC in 2005.

Table 5: Damage Assessment

Type of Defect	Description of the Defect	Action to be Taken
Galvanizing damage on Posts.	The sum total of the damaged or uncoated areas does not exceed 10cm ² (0.5% of the total surface area). The sum total of the damaged or uncoated areas exceeds 10cm ² (0.5% of the total surface area).	An organic zinc rich epoxy paint is to be applied to the repair areas in two coats. The post is to be replaced.
Galvanizing Damage on Wire Rope Cable	The wire rope is nicked or gouged to less than 10% depth. The wire rope is nicked or gouged greater than 10% depth.	An organic zinc rich epoxy paint is to be applied to the repair areas in two coats. The wire rope section is to be replaced.
Mechanical Damage on Wire Rope Cable	Any rope length containing more than 1 broken wire. Any rope where the diameter is reduced by more than 10% by abrasion. Any rope which has been crushed or flattened by more than 10% of its nominal diameter.	The rope section is to be replaced. The rope section is to be replaced The rope section is to be replaced.
Mechanical damage on Posts.	The post is distorted.	The post is to be replaced.
Damaged End Fitting	There is damage to the thread of the fitting, however tension can be maintained in the wire rope system without relying on the fitting. There is damage to the thread of the fitting and tension cannot be maintained in the wire rope system without relying on the fitting. The fitting is cracked. The body of the fitting is distorted.	There is no requirement for immediate replacement. The location of the fitting should be noted and scheduled for replacement during routine maintenance. The fitting is to be replaced. The fitting is to be replaced. The fitting is to be replaced.
Damaged Tension Fitting	The fitting is cracked. The body of the fitting is distorted.	The fitting is to be replaced. The fitting is to be replaced.

Safence Tensioning Report And Checklist

Customer:

Project:

Fence ID:

Fence Length:

Ambient Temperature:

Tensioning Force:

Checked By:

Signed:

Date

End Anchors

Is the anchor block dimensions in accordance with Ingal drawings	<input type="checkbox"/> Yes	<input type="checkbox"/> No
Has the anchor bracket been installed with the levelling plate at the same longitudinal grade as the roadway	<input type="checkbox"/> Yes	<input type="checkbox"/> No
Has each end fitting been secured with one washer and two nuts	<input type="checkbox"/> Yes	<input type="checkbox"/> No

Post Fittings

Have the posts been installed at the correct spacing	<input type="checkbox"/> Yes	<input type="checkbox"/> No
Have the posts been installed with the correct orientation towards approaching traffic	<input type="checkbox"/> Yes	<input type="checkbox"/> No
Have ground covers been attached to the posts	<input type="checkbox"/> Yes	<input type="checkbox"/> No
Have plastic spacers been inserted between each cable	<input type="checkbox"/> Yes	<input type="checkbox"/> No
Has the stainless frame been inserted between the top and second from top cable	<input type="checkbox"/> Yes	<input type="checkbox"/> No
Have post caps been attached to the posts	<input type="checkbox"/> Yes	<input type="checkbox"/> No
Has delineation been attached to the post caps	<input type="checkbox"/> Yes	<input type="checkbox"/> No

Post Fittings – TL4 System Only

Has the post stiffener plate been installed at each post location along the length of need section (plates can be pre-welded or fitted during installation)	<input type="checkbox"/> Yes	<input type="checkbox"/> No
Have rope hooks been attached to each post along the length of need section	<input type="checkbox"/> Yes	<input type="checkbox"/> No

Tension Bays

Have tension bays been installed at not more than 150m from the end anchors	<input type="checkbox"/> Yes	<input type="checkbox"/> No
Have tension Bays been installed at not more than 300m apart	<input type="checkbox"/> Yes	<input type="checkbox"/> No



Figure 16: Safence TL4 (4 Rope)



Figure 17: Safence TL4 (4 Rope)

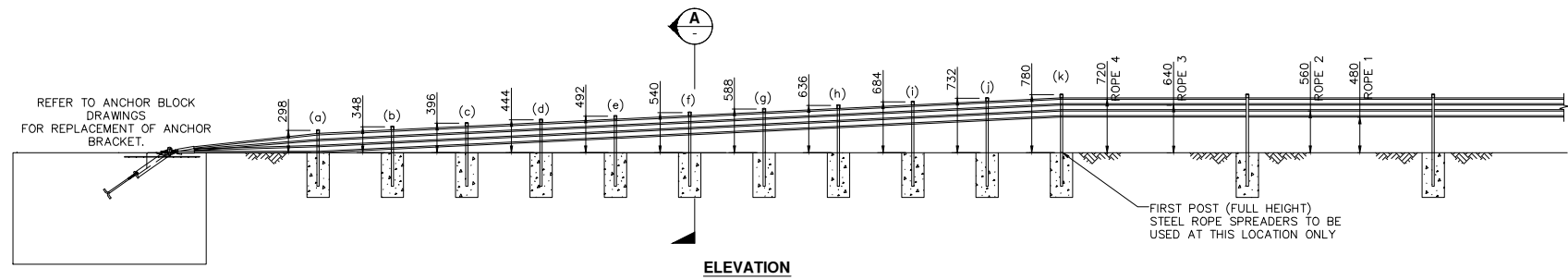

ELEVATION

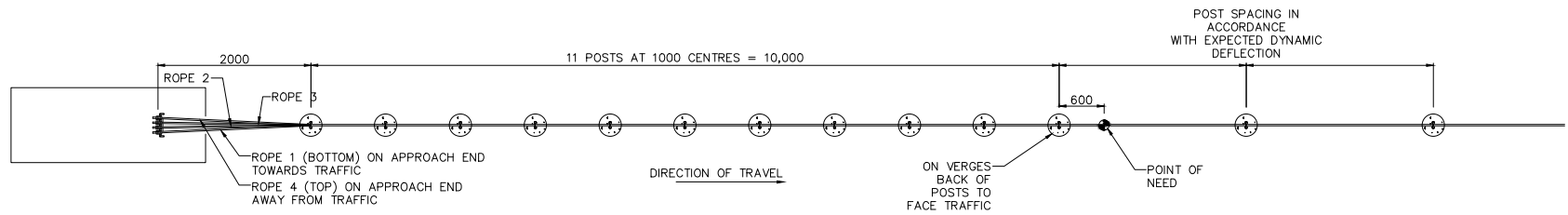

PLAN

ITEM No.	POST LENGTH
a	748
b	798
c	846
d	894
e	942
f	990
g	1038
h	1086
i	1134
j	1182
k	1230

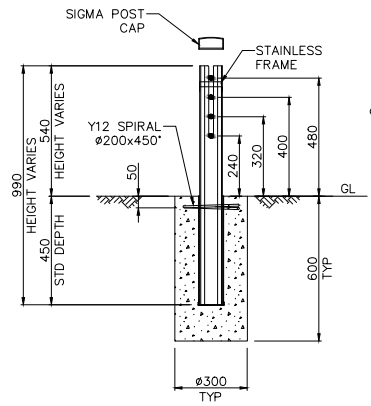

SECTION A

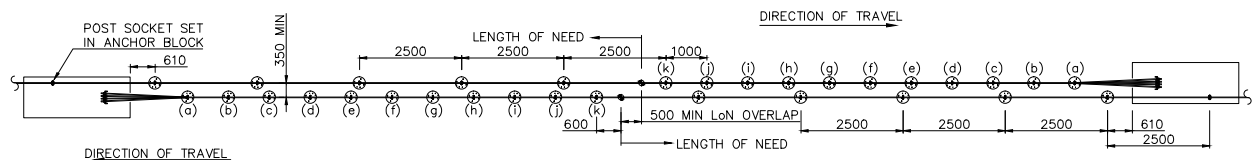

INTERMEDIATE ANCHOR GENERAL ARRANGEMENT
(DIMENSIONS INDICATIVE OF 2.5m BARRIER POST SPACING)

- NOTES:
- DIMENSIONS SHOWN ARE IN mm UNLESS OTHERWISE STATED.
 - THE FLEXFENCE TL3 TERMINAL HAS BEEN APPROVED BY THE US FEDERAL HIGHWAY ADMINISTRATION AS CONFORMING TO NCHRP REPORT 350 TEST LEVEL 3 (TL3) IN A 3 ROPE AND A 4 ROPE CONFIGURATION.
 - THE USE OF A 3 ROPE CONFIGURATION REQUIRES THE OMITMENT OF THE SECOND FROM BOTTOM CABLE.
 - LENGTH OF NEED OVERLAP FOR INTERMEDIATE ANCHOR TO BE 500mm FOR A FLEXFENCE INSTALLATION WITH A POST SPACING OF 2.5m. CONTACT YOUR ICP REPRESENTATIVE FOR OVERLAP WHEN USING A DIFFERENT POST SPACING.

REV	DATE	DESCRIPTION	DRAWN	CHECKED	APPROVED
0		ORIGINAL ISSUE			

REV	DATE	DESCRIPTION	DRAWN	CHECKED	APPROVED
0		ORIGINAL ISSUE			

NAME: MC DATE: 18-10-16
 CHECKED: LG DATE: 18-10-16
 APPROVED: LG DATE: 18-10-16
 SCALE: N.T.S. @ A3
 ISSUE FOR: INFORMATION ONLY



PROJECT: SAFENCE WIRE ROPE SAFETY BARRIER
 TITLE: TL3 END TERMINAL

INGAL CIVIL PRODUCTS PART No.
 DRAWING No. WR-STD-050-NZ
 Rev: 0

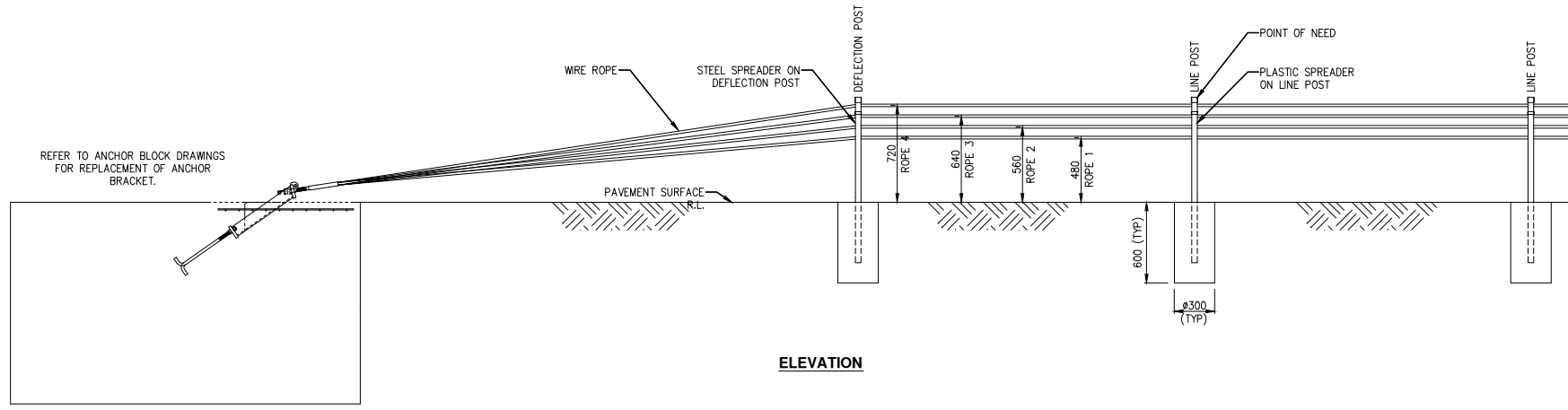

ELEVATION

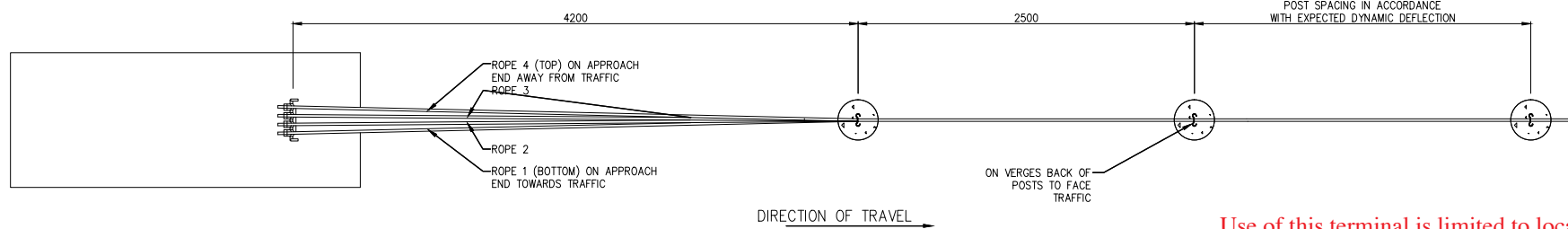

PLAN

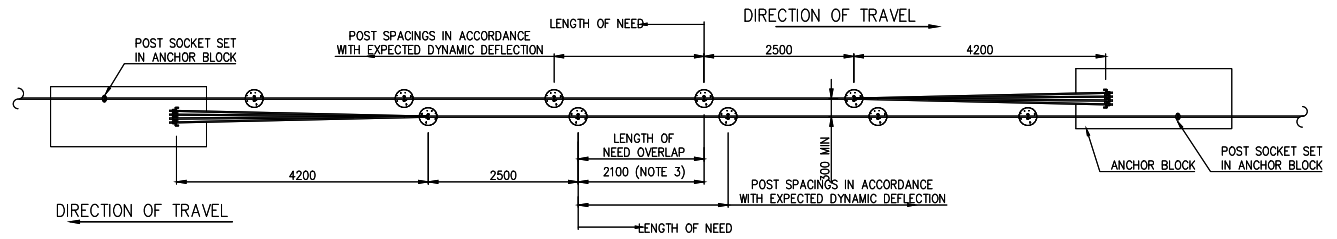

INTERMEDIATE ANCHOR GENERAL ARRANGEMENT

Use of this terminal is limited to locations where geometric constraints limit use of TL3 Terminal. Please contact your local ICP representative for further advice prior to design or installation. Approval may be required from road controlling authority.

- NOTES:
- DIMENSIONS SHOWN ARE IN mm UNLESS OTHERWISE STATED.
 - LENGTH OF NEED OVERLAP FOR INTERMEDIATE ANCHOR TO BE 2100mm FOR A FLEXFENCE INSTALLATION WITH A POST SPACING OF 2.5m, CONTACT YOUR ICP REPRESENTATIVE FOR OVERLAP WHEN USING A DIFFERENT POST SPACING.

REVISIONS			REFERENCES			NAME		DATE		INGAL CIVIL PRODUCTS 57-65 AIRDS ROAD MINTO, N.S.W AUSTRALIA 2566 PH. +61 2 9827 3333 FAX +61 2 9827 3300 www.ingalcivil.com.au	PROJECT	INGAL CIVIL PRODUCTS PART No.
						DRAWN	MC	18-10-16	DRAWING AND CONTENTS ARE COPYRIGHT TO INGAL CIVIL PRODUCTS AND CAN ONLY BE USED WITH PRIOR WRITTEN CONSENT FROM INGAL CIVIL PRODUCTS		SAFENCE WIRE ROPE SAFETY BARRIER	DRAWING No. WR-STD-055-NZ
						CHECKED	LG	18-10-16				
						APPROVED	LG	18-10-16				
						SCALE	N.T.S. @	A3				
						ISSUE FOR	INFORMATION ONLY					
0		ORIGINAL ISSUE				DRAWING NUMBER						
REV	DATE	DESCRIPTION	DRAWN	CHECKED	APPROVED	DRAWING NUMBER	REFERENCE DRAWINGS					

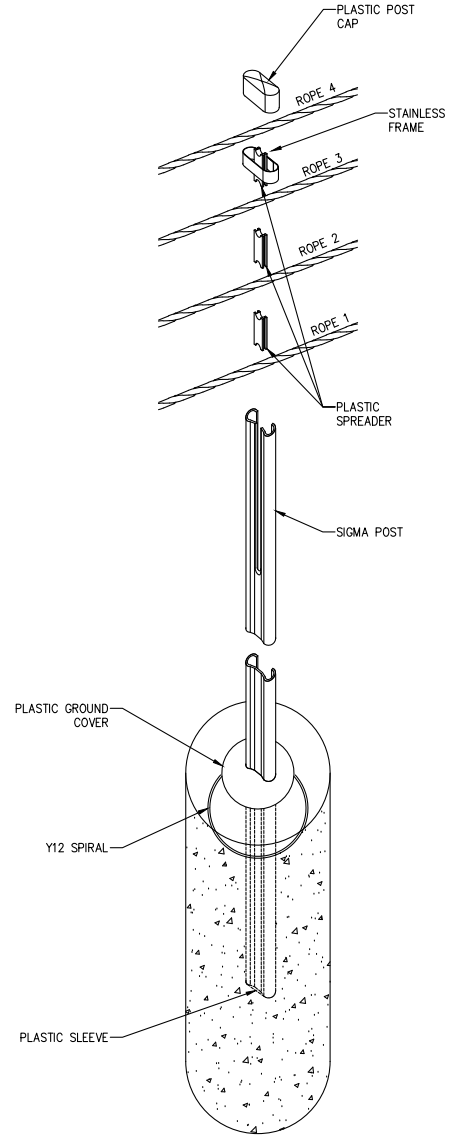
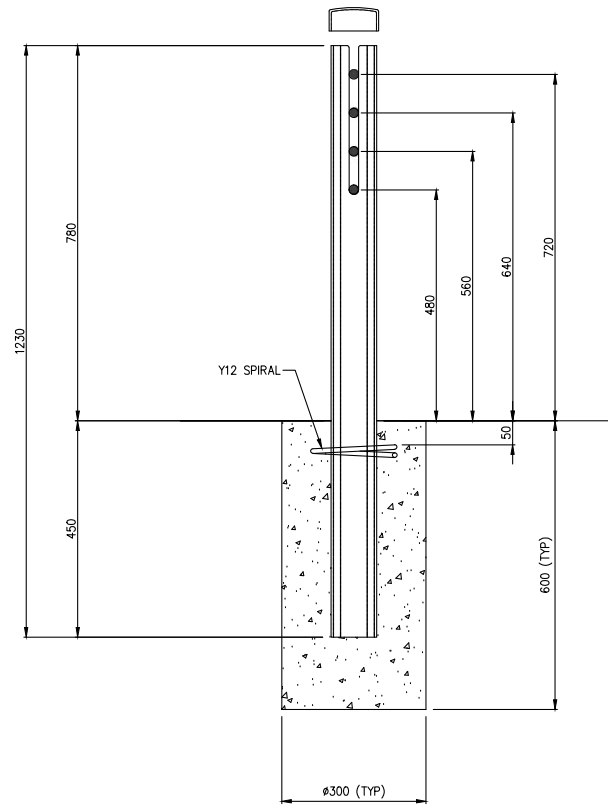

NOTES:

- THE IMPACT CONDITIONS ARE DESCRIBED AS FOLLOWS:
 - TL3 REFERS TO NCHRP REPORT 350 TEST LEVEL 3. THIS IS AN IMPACT WITH A 2,000KG PICK-UP TRUCK TRAVELING AT 100KM/H AND 25 DEGREES.
 - N2 REFERS TO EN1317 CONTAINMENT LEVEL N2. THIS IS AN IMPACT WITH A 1,500KG VEHICLE TRAVELING AT 110KM/H AND 20 DEGREES.
 - H1 REFERS TO EN1317 CONTAINMENT LEVEL H1. THIS IS AN IMPACT WITH A 10,000KG RIGID TRUCK TRAVELING AT 70KM/H AND 15 DEGREES.
- THE DYNAMIC DEFLECTION VALUES SHOULD NOT BE CONSIDERED AN EXACT DISTANCE, BUT RATHER AS A SINGLE POINT WITHIN THE RANGE OF DEFLECTIONS THAT CAN BE EXPECTED.
- STATE ROAD AUTHORITY SPECIFICATIONS SHOULD BE REFERENCED TO OBTAIN APPROVED POST SPACINGS AND RELEVANT MULTIPLYING FACTORS FOR INSTALLATIONS ON CURVES AND/OR VARIATIONS IN BARRIER LENGTHS (IF REQUIRED).
- SIZES OF CONCRETE POST FOOTINGS ARE DEPENDANT UPON LOCAL GROUND CONDITIONS. REFER TO FLEXFENCE PRODUCT MANUAL FOR FOOTING SIZE OPTIONS.
- DIMENSIONS SHOWN ARE IN MILLIMETERS UNLESS OTHERWISE SPECIFIED.
- NOMINAL ROPE TENSION AT 20°C IS 17kN

POST SPACING (M)	DYNAMIC DEFLECTION (M)		
	N2	TL3	H1
2.0	1.0	1.9	2.0
2.5	1.3	2.2	2.5

REV	DATE	DESCRIPTION	DRAWN	CHECKED	APPROVED	DRAWING NUMBER	REFERENCE DRAWINGS	NAME	DATE	PROJECT	TITLE	INGAL CIVIL PRODUCTS PART No.	DRAWING No.	Rev.
0		ORIGINAL ISSUE						MC	18-10-16	SAFENCE WIRE ROPE SAFETY BARRIER	TL3 POST ARRANGEMENT		WR-STD-057-NZ	0
								LG	18-10-16					
								LG	18-10-16					
								N.T.S. @ A3						
								ISSUE FOR	INFORMATION ONLY					

INGAL CIVIL PRODUCTS
A valmont COMPANY

DRAWING AND CONTENTS ARE COPYRIGHT TO INGAL CIVIL PRODUCTS AND CAN ONLY BE USED WITH PRIOR WRITTEN CONSENT FROM INGAL CIVIL PRODUCTS

57-65 AIRDS ROAD
MINTO, N.S.W 2566

PH. +61 2 9827 3333
www.ingalcivil.com.au

J:\SALES & MARKET\DRAWINGS\FLEXFENCE ASSEMBLY\WR-STD-57.DWG

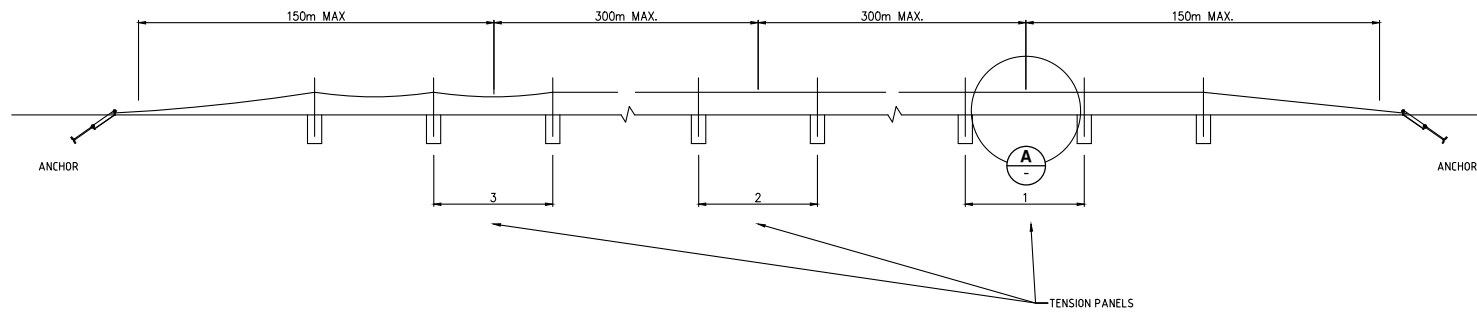

TENSION PANEL LAYOUT

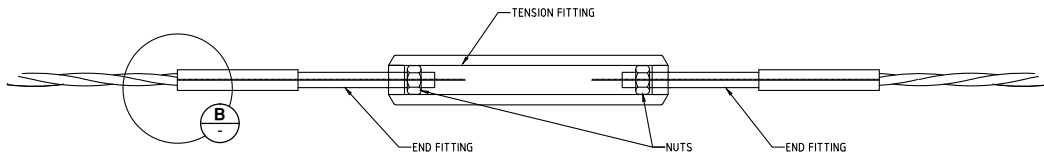

DETAIL A
NTS

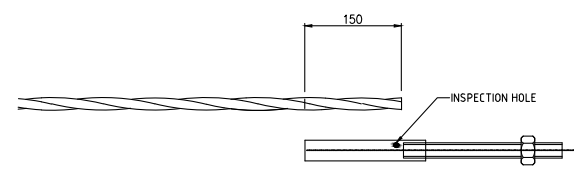

DETAIL B
NTS

NOTES:
1. ALL MEASUREMENTS ARE IN mm UNLESS STATED OTHERWISE.

REVISIONS						REFERENCES			DRAWING INFORMATION			PROJECT		DRAWING INFORMATION		
REV	DATE	DESCRIPTION	DRAWN	CHECKED	APPROVED	DRAWING NUMBER	REFERENCE DRAWINGS	NAME	DATE	SCALE	ISSUE FOR	PROJECT	TITLE	INGAL CIVIL PRODUCTS PART No.	DRAWING No.	Rev.
0		ORIGINAL ISSUE						DRAWN	MC	18-10-16	INFORMATION ONLY	SAFENCE WIRE ROPE SAFETY BARRIER	TENSION PANEL ARRANGEMENT	WR-STD-059-NZ		0
								CHECKED	LG	18-10-16						
								APPROVED	LG	18-10-16						
								SCALE	N.T.S.	@ A3						



DRAWING AND CONTENTS ARE COPYRIGHT TO INGAL CIVIL PRODUCTS AND CAN ONLY BE USED WITH PRIOR WRITTEN CONSENT FROM INGAL CIVIL PRODUCTS
 57-65 AIRDS ROAD PH. +61 2 9827 3333
 MINTO, N.S.W 2566 www.ingalcivil.com.au

J:\SALES & MARKET\DRAWINGS\REFERENCE ASSEMBLY\WR-STD-59- TENSION PANEL ARRANGEMENT.DWG

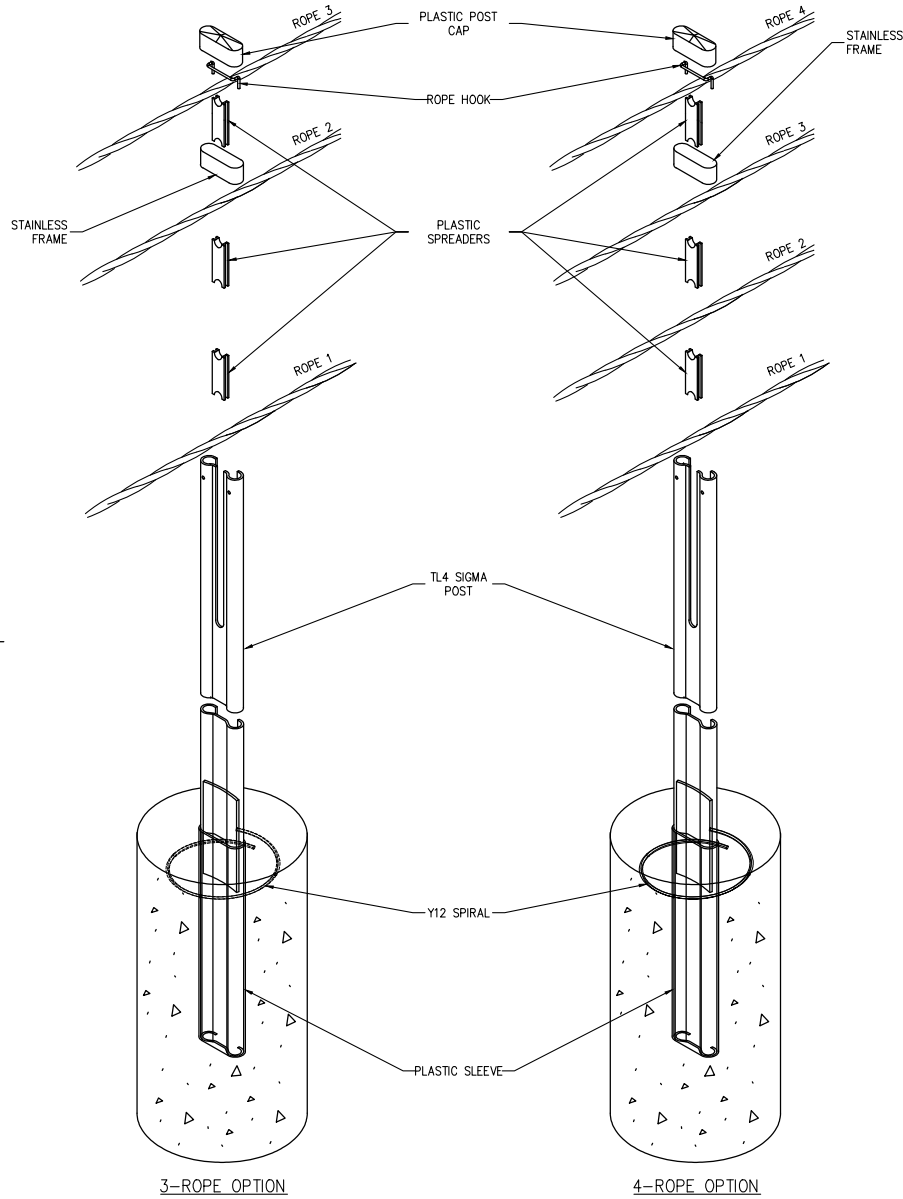
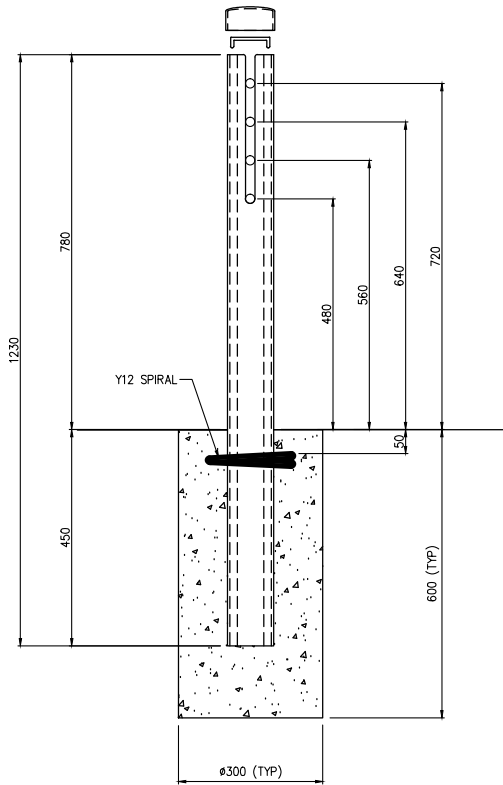

- NOTES:**
- THE IMPACT CONDITIONS ARE DESCRIBED AS FOLLOWS:
 - TL3 REFERS TO NCHRP REPORT 350 TEST LEVEL 3. THIS IS AN IMPACT WITH A 2,000KG PICK-UP TRUCK TRAVELING AT 100KM/H AND 25 DEGREES.
 - TL4 REFERS TO NCHRP REPORT 350 TEST LEVEL 4. THIS IS AN IMPACT WITH AN 8,000KG RIGID TRUCK TRAVELING AT 80KM/H AND 15 DEGREES. FLEXFENCE TL4 HAS BEEN APPROVED BY THE US FEDERAL HIGHWAY ADMINISTRATION AS A 3 ROPE OR 4 ROPE BARRIER.
 - THE DYNAMIC DEFLECTION VALUES SHOULD NOT BE CONSIDERED AN EXACT DISTANCE, BUT RATHER AS A SINGLE POINT WITHIN THE RANGE OF DEFLECTIONS THAT CAN BE EXPECTED.
 - STATE ROAD AUTHORITY SPECIFICATIONS SHOULD BE REFERENCED TO OBTAIN APPROVED POST SPACINGS AND RELEVANT MULTIPLYING FACTORS FOR INSTALLATIONS ON CURVES AND/OR VARIATIONS IN BARRIER LENGTHS (IF REQUIRED).
 - SIZES OF CONCRETE POST FOOTINGS ARE DEPENDANT UPON LOCAL GROUND CONDITIONS. REFER TO FLEXFENCE PRODUCT MANUAL FOR FOOTING SIZE OPTIONS.
 - DIMENSIONS SHOWN ARE IN MILLIMETERS UNLESS OTHERWISE SPECIFIED

POST SPACING (M)	DYNAMIC DEFLECTION (M)	
	TL3*	TL4*
2.0	1.3	1.1
2.5	1.4	1.2
3.0	1.6	1.3

* CABLE TENSION SET TO 25kN

REV	DATE	DESCRIPTION	DRAWN	CHECKED	APPROVED	DRAWING NUMBER	REFERENCE DRAWINGS	NAME	DATE	PROJECT	INGAL CIVIL PRODUCTS PART No.
0		ORIGINAL ISSUE						MC	18-10-16	SAFENCE WIRE ROPE SAFETY BARRIER	
								LG	18-10-16	TL4 POST ARRANGEMENT	DRAWING No.
								LG	18-10-16		WR-STD-060-NZ
											Rev. 0

INGAL CIVIL PRODUCTS
A valmont COMPANY

DRAWING AND CONTENTS ARE COPYRIGHT TO INGAL CIVIL PRODUCTS AND CAN ONLY BE USED WITH PRIOR WRITTEN CONSENT FROM INGAL CIVIL PRODUCTS

57-65 AIRDS ROAD MINTO, N.S.W 2566 PH. +61 2 9827 3333 www.ingalcivil.com.au

J:\SULES & MARKET\ING\DRAWINGS\FLEXFENCE\ASSEMBLY\WR-STD-060-TL4 POST ARRANGEMENT.DWG

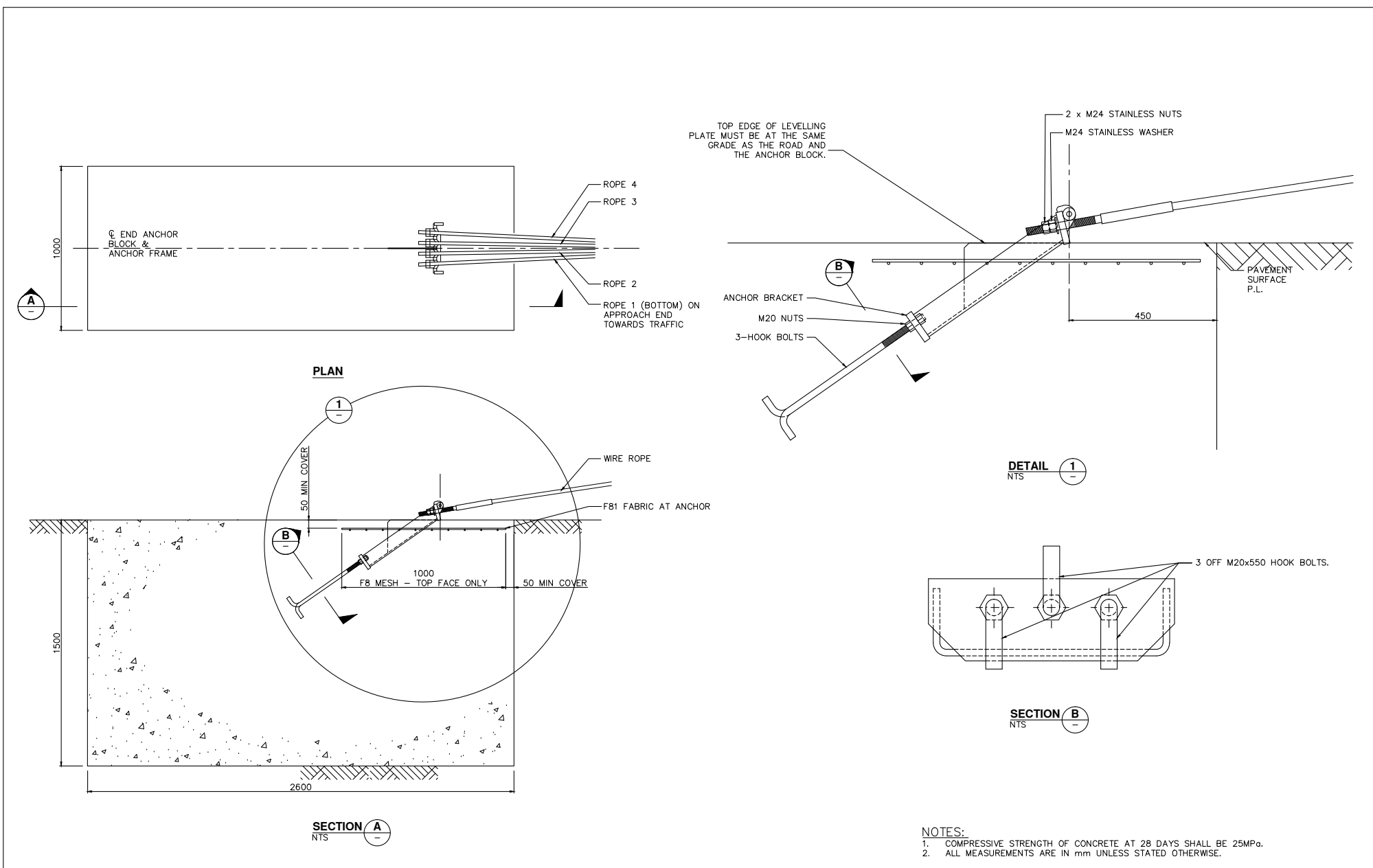

REV	DATE	DESCRIPTION	DRAWN	CHECKED	APPROVED	DRAWING NUMBER	REFERENCE DRAWINGS	NAME	DATE	PROJECT	INGAL CIVIL PRODUCTS PART No.
0		ORIGINAL ISSUE						MC	18-10-16	SAFENCE WIRE ROPE SAFETY BARRIER	
								LG	18-10-16	RECTANGULAR (TYPE 1) ANCHOR BLOCK	
								LG	18-10-16		WR-STD-062-NZ
											Rev: 0

J:\SALES & MARKETING\DRAWINGS\SAFENCE\ASSEMBLY\WR-STD-062-TYPE 1 ANCHOR BLOCK.DWG

INGAL CIVIL PRODUCTS
A valmont COMPANY
 DRAWING AND CONTENTS ARE COPYRIGHT TO INGAL CIVIL PRODUCTS AND CAN ONLY BE USED WITH PRIOR WRITTEN CONSENT FROM INGAL CIVIL PRODUCTS
 57-65 AIRDS ROAD PH. +61 2 9827 3333
 MINTO, N.S.W 2566 www.ingalcivil.com.au

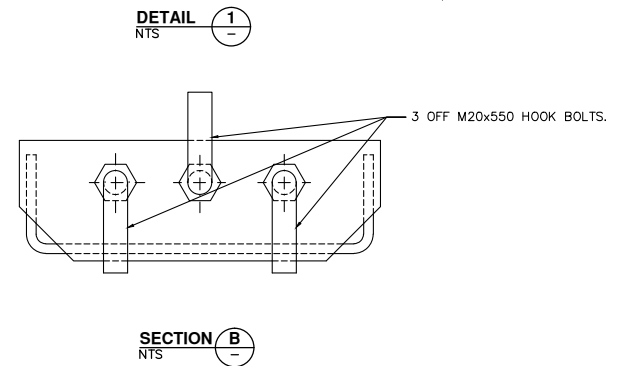
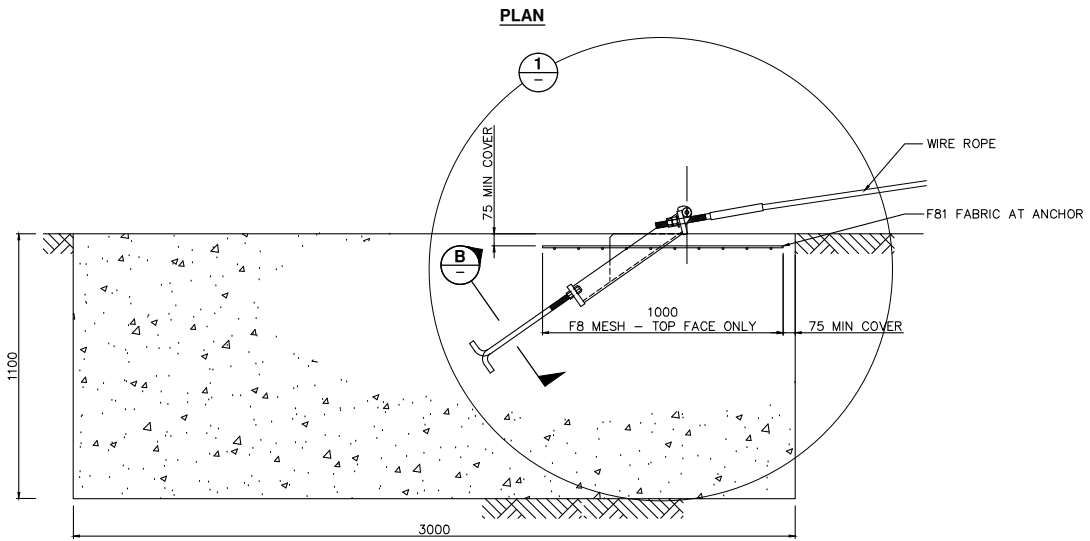
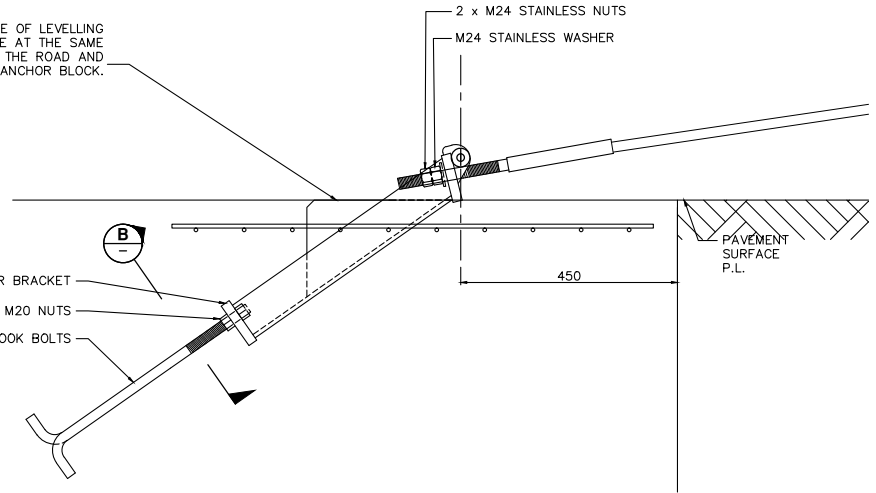
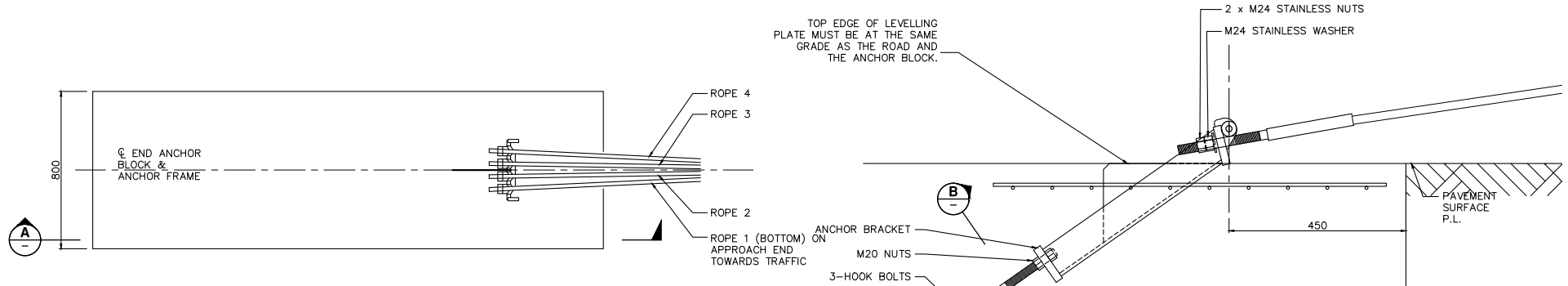

- NOTES**
1. CONCRETE TO HAVE MINIMUM 28 DAY STRENGTH OF 30 MPa.
 2. MINIMUM CLEAR COVER TO BE 75 mm.
 3. THE AVERAGE MATERIAL-INTERNAL ANGLE OF FRICTION OVER THE DEPTH OF THE ANCHOR WHEN MEASURED USING AN APPROVED METHODOLOGY SHALL EXCEED THE FOLLOWING:
 - $\Phi = 30$ DEGREES
 - $\gamma = 19$ kN/m³
 - $C_u = 35$ kPa
 4. FOR SITES WITH UNCONVENTIONAL GEOMETRIES, HIGH WATER TABLES, ALTERNATIVE SOIL TYPES, OR UNUSUAL SITE SPECIFIC VARIABLE, AN ALTERNATIVE ANCHOR DESIGNS WILL BE REQUIRED. PLEASE SEEK ADVICE FROM A QUALIFIED GEOTECHNICAL ENGINEER OR YOUR LOCAL INGAL SALES REPRESENTATIVE.
 5. FOR MIXED SOIL TYPES, A CONSERVATIVE APPROACH OF ASSUMING THE WEAKER SOIL PROPERTIES FOR THE FULL DEPTH IS RECOMMENDED. OTHERWISE, CONTACT A QUALIFIED GEOTECHNICAL ENGINEER.
 6. FOR ADDITIONAL GUIDANCE, PLEASE CONTACT YOUR LOCAL INGAL SALES REPRESENTATIVE.
 7. ALL UNITS ARE IN MM UNLESS NOTED OTHERWISE.

REV	DATE	DESCRIPTION	DRAWN	CHECKED	APPROVED
0		ORIGINAL ISSUE			

DRAWING NUMBER	REFERENCE DRAWINGS

NAME	DATE
DRAWN MC	18-10-16
CHECKED LG	18-10-16
APPROVED LG	18-10-16
SCALE	N.T.S. @ A3
ISSUE FOR	INFORMATION ONLY

DRAWING AND CONTENTS ARE COPYRIGHT TO INGAL CIVIL PRODUCTS AND CAN ONLY BE USED WITH PRIOR WRITTEN CONSENT FROM INGAL CIVIL PRODUCTS
 57-65 AIRDS ROAD MINTO, N.S.W 2566 PH. +61 2 9827 3333 www.ingalcivil.com.au

PROJECT	SAFENCE WIRE ROPE SAFETY BARRIER
TITLE	RECTANGULAR (TYPE 3) ANCHOR BLOCK

INGAL CIVIL PRODUCTS PART No.	
DRAWING No.	WR-STD-064-NZ
Rev:	0

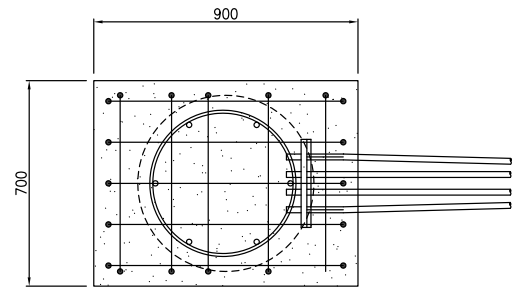
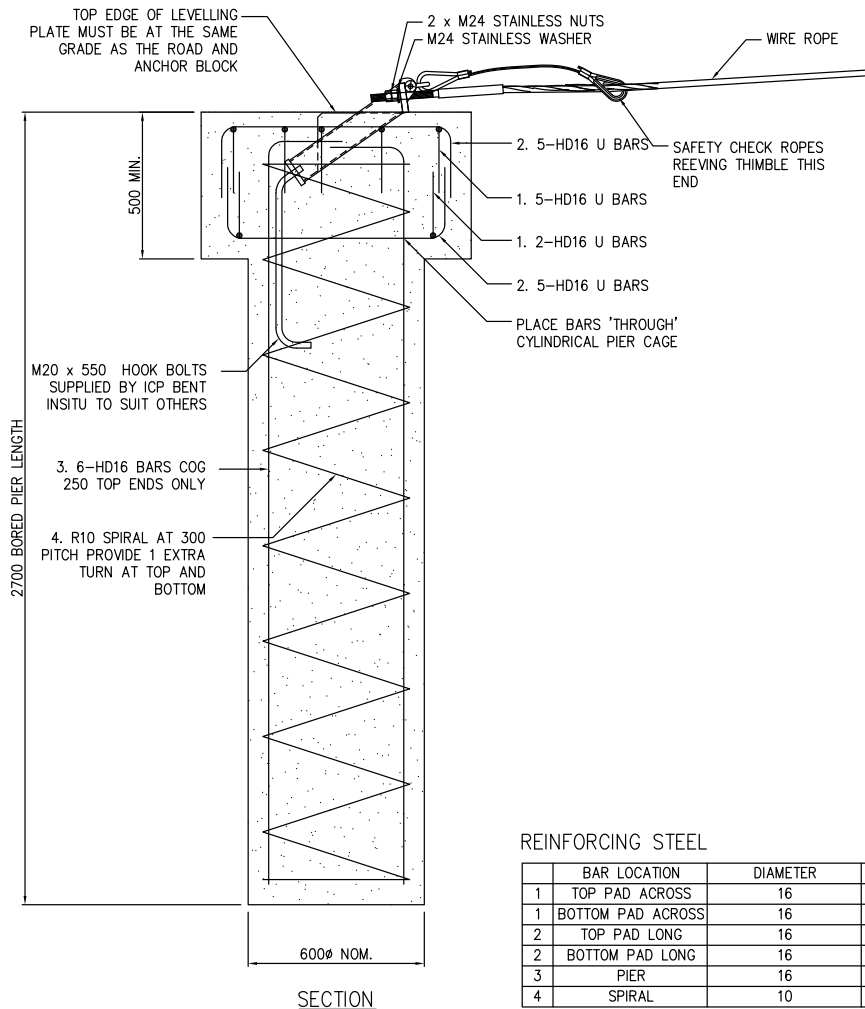

PLAN VIEW

NOTES:

1. CONCRETE TO BE 32MP_a MINIMUM.
2. MINIMUM CLEAR COVER TO BE 75mm.
3. HD BAR DENOTES GRADE 500E TO AS/NZS 4671. R BAR DENOTES 300E TO AS/NZS 4671.
4. ASSUMED MATERIAL-INTERNAL ANGLE OF FRICTION $\phi = 30^\circ$
 $\gamma = 19\text{kN/m}^3$
 $C_u = 50\text{kPa}$
 or/
 ICP DISTRIBUTE THIS WRSB SYSTEM UNDER THE PRODUCT NAME SAFENCE IN NEW ZEALAND. REFER NZTA APPROVAL LETTER FOR APPROVED CONFIGURATION.

REINFORCING STEEL

	BAR LOCATION	DIAMETER	GRADE	No. OF BARS	STRAIGHT LENGTH	RETURNS/PITCH	TOTAL LENGTH	WEIGHT
1	TOP PAD ACROSS	16	500E	5	500	600	5.5	8.63kg
1	BOTTOM PAD ACROSS	16	500E	2	500	600	2.2	3.45kg
2	TOP PAD LONG	16	500E	5	600	600	6	9.41kg
2	BOTTOM PAD LONG	16	500E	5	600	600	6	9.41kg
3	PIER	16	500E	6	2600	250	17.1	26.82kg
4	SPIRAL	10	500E	1	15352	300	15.4	9.41kg
								67.1kg

REV	DATE	DESCRIPTION	DRAWN	CHECKED	APPROVED	DRAWING NUMBER	REFERENCE DRAWINGS	NAME	DATE	INGAL CIVIL PRODUCTS 57-65 AIRDS ROAD MINTO, N.S.W AUSTRALIA 2566 PH. +61 2 9827 3333 FAX +61 2 9827 3300 www.ingalcivil.com.au	PROJECT SAFENCE WIRE ROPE SAFETY BARRIER	INGAL CIVIL PRODUCTS REFERENCE No.
2	08/02/13	SAFENCE NOTE ADDED	LG	SE	LRB	WR-STD-47	PIER FOOTING IN ROCK (2005)	DRAWN	AUSTEC	04/01/2012	DRAWING AND CONTENTS ARE COPYRIGHT TO INGAL CIVIL PRODUCTS AND CAN ONLY BE USED WITH PRIOR WRITTEN CONSENT FROM INGAL CIVIL PRODUCTS	DRAWING No. WR-STD-82
1	04/01/12	INITIAL ISSUE	DJB	TC	TC	WR-STD-48	PIER FOOTING IN MEDIUM CLAY (2005)	CHECKED	TC	04/01/2012		
						WR-STD-49	PIER FOOTING IN DENSE SAND & GRAVEL (2005)	APPROVED	TC	04/01/2012		
								SCALE	NTS		TITLE PIER (TYPE 4) ANCHOR BLOCK	
								SIZE	A1			REV. 2



INGAL
CIVIL PRODUCTS
A valmont  COMPANY

For more information

contact us on the web

www.ingalcivil.co.nz

Auckland
40 Tironui Road, Takanini
Auckland 2112 New Zealand
Ph: 0212 464 997

Christchurch
Ph: 0211 983 311
Email: sales@ingalcivil.co.nz

Head Office: Sydney
57-65 Airds Road, Minto, NSW 2566
Ph: +61 2 9827 3333
Fax: +61 2 9827 3300
Free call (within Australia):
1800 803 795
Email: sales@ingalcivil.com.au