



**EZY-GUARD** HC  
INGAL CIVIL PRODUCTS



*Product Manual*



Release 10/23

[www.ingalcivil.co.nz](http://www.ingalcivil.co.nz)

## 1.0 Introduction

Introducing Ezy-Guard HC, a member of the Ezy-Guard family, the next generation steel guardrail barrier providing superior motorist safety and more metres of barrier for your dollar.

Ezy-Guard HC is crash tested to the latest performance standard distinguishing it from all existing public domain guardrail barrier systems in New Zealand.

The Z-post profile shields post edges from vulnerable road users and provides sectional strength when driving through difficult conditions.

An Ezy-HC-Carriage is used to secure the Thrie-beam rails to the posts eliminating the requirement for blocking/offset pieces and rail stiffening plates. This unique connection provides a soft ride-down for the occupants and smooth vehicle containment and redirection.

## 2.0 Specifications

Ezy-Guard HC Z-Post Length: 2,000mm

Ezy-Guard HC Z-Post Mass: 19.5kg

Ezy-Guard HC System Mass: 28.8kg per metre

Rail Height Above Ground: 980mm

Z-Post Height Above Ground: 970mm

Post Spacing: 2,000mm

Ezy-Guard HC System Width: 245mm

MASH TL3 Crash Test Deflection: 1.16m

MASH TL4 Crash Test Deflection: 1.20m

Ezy-Guard HC Thrie-beam rails and Z-posts are manufactured from hot-rolled steel flat products in accordance with AS/NZS 1594. These items are hot dip galvanised in accordance with AS/NZS 4680 after fabrication leaving no surface untreated.

State specific product acceptance details are available upon request from your local Ingal representative. Acceptance of product variants should be confirmed prior to installation.

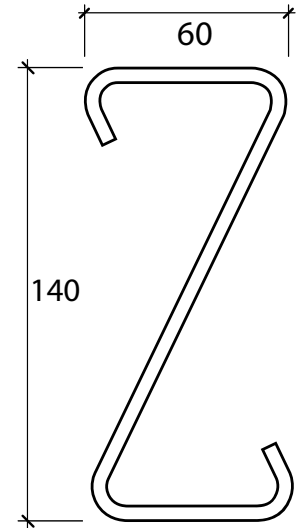

BARRIER SELECTION TABLE					
Guardrail System	Performance Class	Deflection	Working Width	Surface Mount Option	Environmental Protection
Ezy-Guard 4	MASH TL3 NCHRP-350 TL4	1.65m -	1.65m -	Yes	Hot Dip Galv to AS/NZS 4680
Ezy-Guard HC	MASH TL4 MASH TL3 NCHRP-350 TL4	1.20m 1.16m 1.00m	1.80m 1.16m -	Yes	Hot Dip Galv to AS/NZS 4680



### 3.0 Crash Test Analysis

Crash test guidelines provide a minimum set of requirements that a roadside barrier has to meet in order to demonstrate its satisfactory impact performance.

Whilst crash test guidelines cannot include all possible impact conditions that may be experienced in the real world, the crash test matrix is selected to represent a "worst practical condition" for a roadside barrier impact.

Ezy-Guard HC has been fully crash tested and evaluated according to the specifications for Test Level 4 (TL4) of the AASHTO Manual for Assessing Safety Hardware (MASH) and also to NCHRP-350 Test Level 4.

The MASH specification is an update to and supersedes NCHRP Report 350 for the purposes of evaluating new safety hardware devices.

In the revised standard AS/NZS 3845.1:2015, MASH has been nominated as the basis of testing procedures for road safety barrier systems.

The MASH TL4 crash test matrix requires the following impacts;

- 1,100kg car travelling at 100km/h and 25 degrees.
- 2,270kg pick-up travelling at 100km/h and 25 degrees.
- 10,000kg truck travelling at 90km/h and 15 degrees.

Crash test impact conditions are defined by the mass, speed, and angle of the impacting vehicle. Crash test standards and performance levels can be compared by calculating the impact severity (IS).

$$IS = \frac{1}{2} M (V \sin \theta)^2$$

Where IS is the impact severity in joules (J), M is the test inertial mass of the vehicle in kilograms (kg), V is the impact speed in metres/second (m/s) and  $\theta$  is the impact angle in degrees.

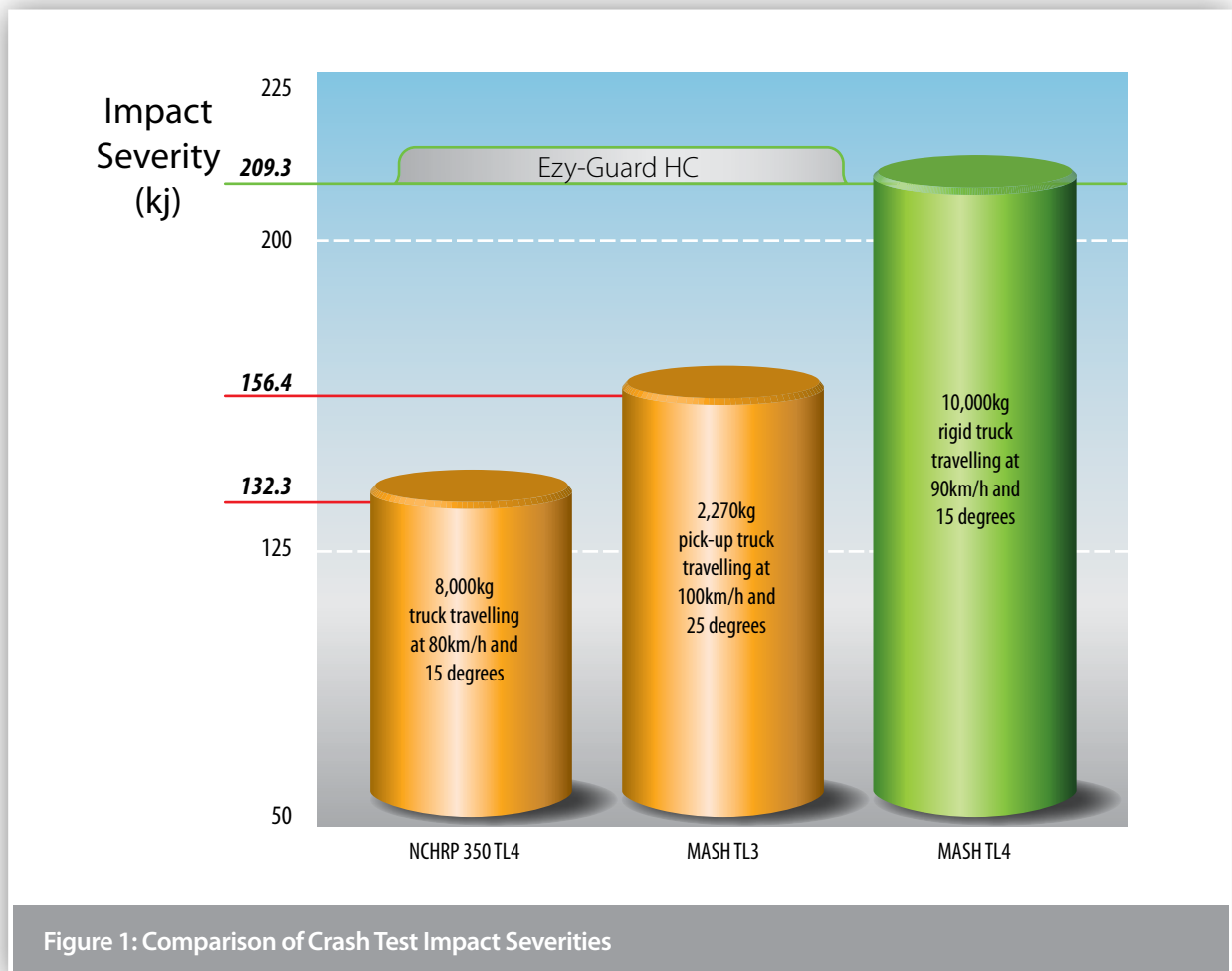

Figure 1: Comparison of Crash Test Impact Severities

#### 4.0 Consideration for Vulnerable Road Users

Vulnerable road users include motorcyclists, pedestrians, cyclists and other road users. Ezy-Guard HC has been designed to provide consideration to vulnerable road users as follows:

##### Rounded Post Corners.

The Z-post contains smooth, rounded post edges and corners mitigating the risk and severity of fractures and/or contusions.

##### Energy Absorbing, Ductile Z-Posts.

The Z-posts are designed to yield by bending near ground level. This bending action absorbs impact energy reducing the potential for post fracturing. A fractured or split guardrail post presents a significant laceration hazard to vulnerable road users.

The Ezy-Guard HC design does not contain any elements that become projectiles and there are no aggressive edges.

##### Shielded Posts.

The innovative design of Ezy-Guard HC shields the top of the supporting Z-posts by positioning the top of the

rail above the posts. This eliminates dangerous snag points, reducing the potential for the barrier to dismount motorcyclists or cyclists. This is a significant safety benefit compared to traditional guardrail and cable barrier systems.

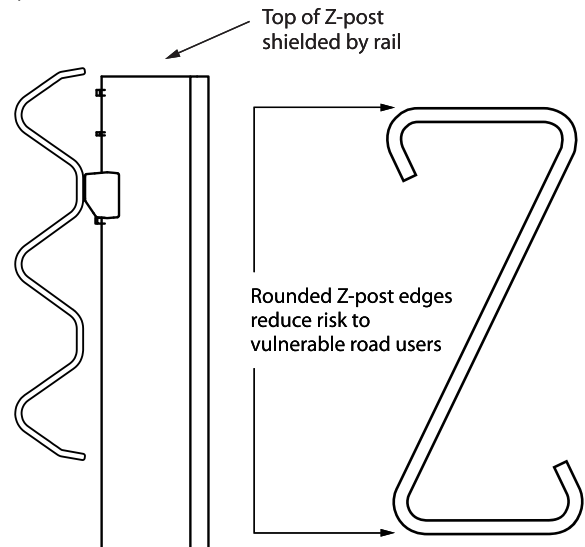

Figure 2: Ezy-Guard HC Considerations for Vulnerable Road Users



## 5.0 Features and Benefits

### 5.1 Fully Compliant to MASH TL4

Ezy-Guard HC, a member of the Ezy-Guard family, is fully compliant to MASH TL4.

The MASH TL4 test condition represents a larger impact energy when compared to NCHRP 350 Test Level 4 impacts.

The MASH TL4 compliance demonstrates the systems ability to contain and redirect the 10,000kg truck which is 2000kg heavier than the NCHRP-350 TL4 truck.

**MASH TL3 COMPLIANT**

**NCHRP-350 TL4 COMPLIANT**

**MASH TL4 COMPLIANT**

### 5.2 Rapid Installation & Repair

Ezy-Guard HC installation can be up to twice as fast to install than conventional guardrail barriers and unlike cable barrier systems, no concrete is required.

The Ezy-Guard HC design uses fewer components and features 2,000mm Z-posts that are rapidly driven into the ground. The Z-post embedment depth is just 1,030mm, a significant reduction when compared to other Thrie-beam guardrail posts. This reduces installation time providing significant cost savings.

Since the Z-posts are designed to yield by bending near ground level, damaged posts can be removed easily which reduces the time spent by work crews on the roadside.

### 5.3 Narrow Width

With a system width of just 245mm, Ezy-Guard HC is significantly narrower than the traditional guardrail barriers that incorporate the use of blocking pieces. Ezy-Guard HC conserves valuable formation width and allows a greater recovery width to be provided for errant vehicles.

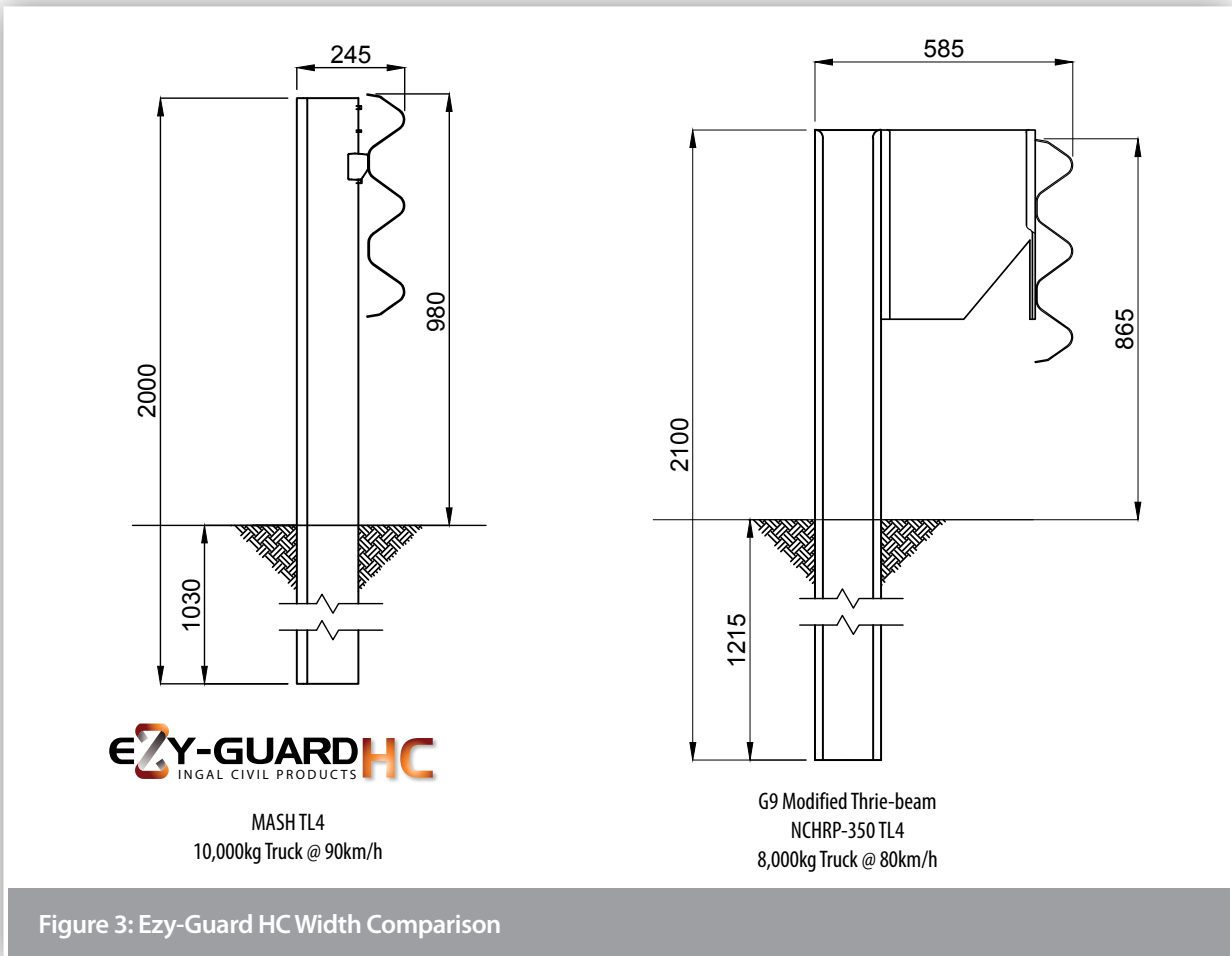

Figure 3: Ezy-Guard HC Width Comparison

#### 5.4 Installation in Rock, Asphalt or Concrete Mowing Strips

The design of the Z-post differs from traditional posts in that it relies on the yielding of the post by bending near ground level rather than the yielding of the surrounding soil during a vehicle impact. This makes the Z-post suitable for installation in rock, asphalt or concrete mowing strips.

A traditional guardrail post is designed to absorb some crash energy through post rotation in the soil prior to post failure. Restraining these traditional posts by setting them in narrow holes drilled into solid rock, by setting them in thick asphalt layers or concrete, or by placing a mowing strip around the posts can lead to a failure of the system to safely contain and redirect the errant vehicle.

#### 5.5 Manual Handling

Ezy-Guard HC uses fewer components than the public domain guardrail systems. Z-posts weighing just 19.5kg are lighter than traditional Thrie-beam posts. The lightweight Z-post reduces manual lifting by installation crews.

The rounded edges of the Z-post provides a handlelike grip when lifting, reducing the possibility of hand lacerations. The Z-profile allows the installer to maintain a firm grip and facilitates correct lifting techniques.

#### 5.6 Locally Designed & Produced

Ezy-Guard HC is manufactured in New Zealand by Ingal Civil Products using steel manufactured by BlueScope Steel. Z-posts and rail are stamped providing traceability to material mechanical and chemical analysis certificates. Hot dip galvanising is performed internally by Ingal and daily inspections ensure zinc thickness readings are in accordance with AS/NZS standards..

#### 5.7 Soft Ride-Down Decelerations

The Ezy-HC-Carriage controls the release of the Thrie-beam rail from the Z-posts. This controlled release reduces the potential for vehicle pocketing and provides a soft ridedown for vehicle occupants.



## 6.0 Performance

Ezy-Guard HC provides protection from roadside hazards located close to the edge of the travelled way. The sectional strength of the Z-post reduces lateral deflection whilst providing controlled containment and redirection.

Crash testing guidelines provide a set of requirements that is "worst practical conditions" in order to demonstrate the barriers impact performance. When the combined effects of vehicle mass, impact speed and angle of impact are considered, the testing criteria represents the extremes of impact conditions to be expected in realworld situations.

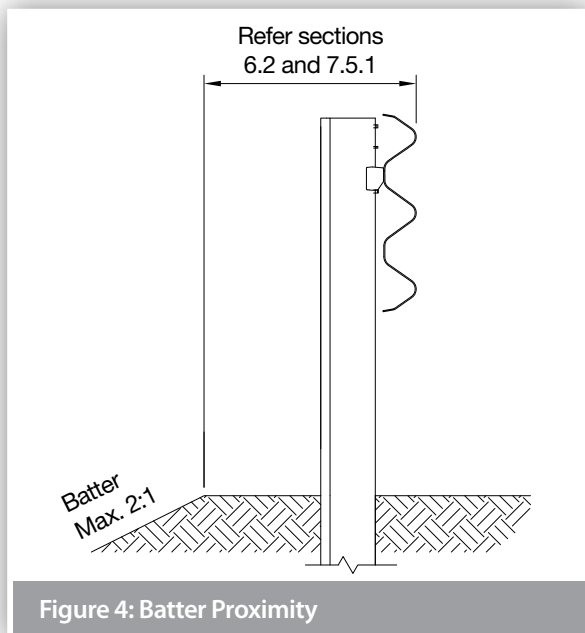

Figure 4: Batter Proximity

## 6.1 Deflection

The transverse deflection of a barrier during a crash is dependent upon a number of factors, including the following:

- Mass of the impacting vehicle;
- Speed of the impact vehicle; and
- Angle of the vehicle impact.

The MASH TL3 deflection for Ezy-Guard HC is 1.16m and the MASH TL4 deflection is 1.2m. The NCHRP-350 TL4 deflection is 1.0m. A range of deflections for TL2 and TL3 can be found in Table 1.

## 6.2 Slopes

The maximum cross fall for an installation of Ezy-Guard HC is 10H:1V (10%).

Proximity to a batter slope will depend on the required containment level and batter gradient. For a TL3 containment, the posts can be installed up to the rounding point for batter gradients no steeper than 2H:1V. Please note, this will likely fall into the Extended Design Domain and will require a risk assessment. For a TL4 containment, the onset from face of rail to the hinge point should be equal to the expected deflection, refer section 6.1.

For locations with slopes steeper than 2H:1V, please refer to our Ezy-Guard LDS slope option.



Table 1: Dynamic deflections under various post spacing and impact speeds

Containment Level		Vehicle: 2,270 kg Impact Angle: 25°			
		Speed (km/h)	Post Spacing (m)		
			2	1	0.5
Dynamic Deflection (m)	MASHTL3	100	1.16	0.81	0.53
		80	0.8	0.6	*
	MASHTL2	70	0.69	0.5	0.27
		60	0.59	0.35	*

\* Not currently available. Please contact your local Ingal Civil representative for more information.



## 7.0 Installation

### 7.1 Terminals

Guardrail end terminals are installed at the beginning and end of a run of guardrail. Their primary purpose is to anchor the longitudinal barrier and to minimise deflection. Crashworthy terminals are typically used in locations where they can be impacted end-on as they are designed to provide a soft gating impact if impacted near the end rail. This prevents any spearing of an errant vehicle. Part of the end-terminal may also be redirective.

Ezy-Guard HC is installed at a system height of 980mm, measured to the top of the rail. This height is compatible with our asymmetric 1,905mm transition bracket and the ET-SS or TREND Median terminals, refer to installation drawings.

Terminals should be installed in accordance with the proprietor's drawings and specifications. Z-posts are not to be used in the terminals unless approved by the proprietor.

The installation of terminals will typically incorporate the use of blocking/offset pieces positioned between the posts and rail. This will require the supporting posts to be offset from the set-out line used for the installation of the Z-posts which do not require blocking pieces.

In addition, the post spacing used in the terminals and transitions may vary from the 2m spacing used for installation of Ezy-Guard HC. The required post spacing for terminals and transitions will be contained in the proprietor's drawings.

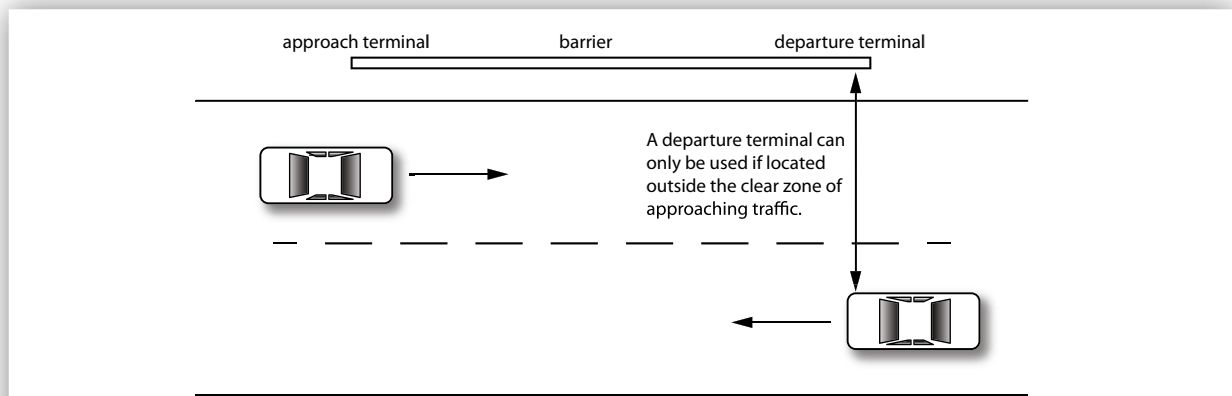

Figure 5: Clear Zone Requirement for the use of Departure Terminals



## 7.2 Minimum Length Requirements

There are two geometric methods used to determine the likely trajectory of a vehicle that leaves the road in the vicinity of a roadside hazard and the minimum length of barrier required to protect from this hazard.

The most common method is the run-out length method and an alternative is a method based on angle of departure.

Prior to design or installation, designers should consult the relevant road controlling authority to establish the local jurisdictional practice as the methods may result in different lengths. Both methods are detailed in the Austroads Guide to Road Design – Part 6.3.

For instances where geometric constraints limit the installation of the recommended length under these methods, the absolute minimum length of need for Ezy-Guard HC is dependent on the design containment level. The following values were taken from the vehicle to barrier contact length in crash testing and may be regarded as departure from normal design domain (NDD) in some jurisdictions.

- MASH Test Level 3 containment, where the design vehicle is a 2,270kg pick-up, the minimum length of Ezy-Guard HC is 20m.
- MASH Test Level 4 containment, where the design vehicle is a 10,000kg truck, the minimum length of Ezy-Guard HC is 26m.

For measurement of minimum length, refer Figure 7.

## 7.3 Sequence of Work

Where Ezy-Guard HC is being constructed on a road open to traffic, it is recommended that the work commence at the end closest to the approaching traffic. Leading terminals and transitions shall be commissioned at the earliest practical time.

## 7.4 Modifications

Ezy-Guard HC shall be constructed in the configuration as detailed in Ingal Civil Products' drawings. This is the configuration in which the system has been crash tested.

No modifications shall be made to the system unless verified by Ingal Civil Products.

Flame cutting of rails or posts is not permitted. Saw cutting and drilling is permitted in the event that a post is to be installed at an irregular spacing and/or rock is encountered and the post embedment depth has been modified.

Any modification carried out after fabrication will require repair to the galvanized coating. This is undertaken by applying two coats of an organic zinc rich epoxy paint complying with AS/NZS 3750.9. This is to be applied to the repair areas in two coats. Each coat shall have a minimum dry film thickness of 50 µm.

## 7.5 Soil Requirements & Embedment Depth

The Z-post is designed to yield by bending near ground level during impact. Provided the post is embedded in material that allows this failure mechanism to be replicated, the Ezy-Guard HC functionality will be retained. The Z-posts will provide lateral resistance until the impacting vehicle causes deformation of the posts. At this point the Ezy-HC-Carriages will provide a controlled release of the rail from the Z-posts resulting in safe vehicle containment and redirection.

### 7.5.1 Standard Soil

Ezy-Guard HC has been evaluated for installation in standard soil in accordance with AASHTO standard specifications for 'Materials for Aggregate and Soil Aggregate Subbase, Base and Surface Courses,' designation M 147.

When installed in weak soil, the 1,030mm embedment depth of the Z-post is sufficient for installation up to 500mm of the rounding point on 2:1 embankment slopes. If installation is required within 500mm of the rounding point, the post embedment depth is required to be increased to 1,350mm. A longer Z-post is available from Ingal Civil for these applications.

For a TL4 containment level, installations with the hinge point within the expected deflection zone should be considered under the requirements of the road controlling authority Extended Design Domain.

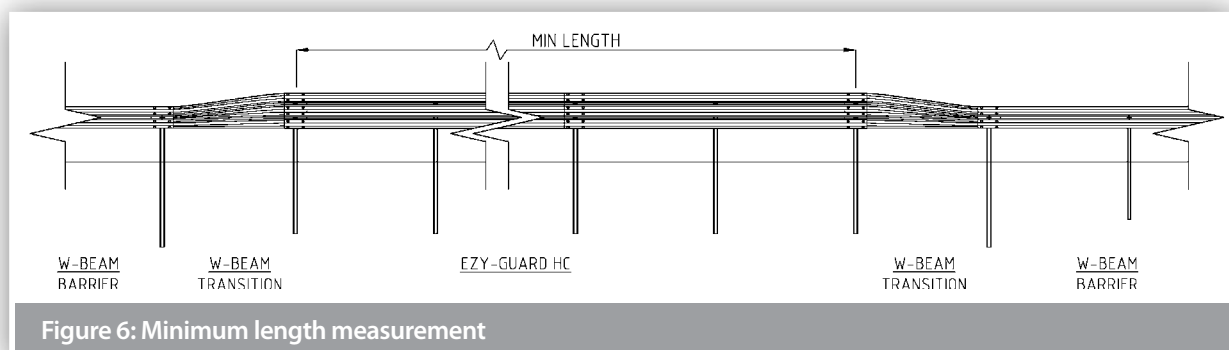
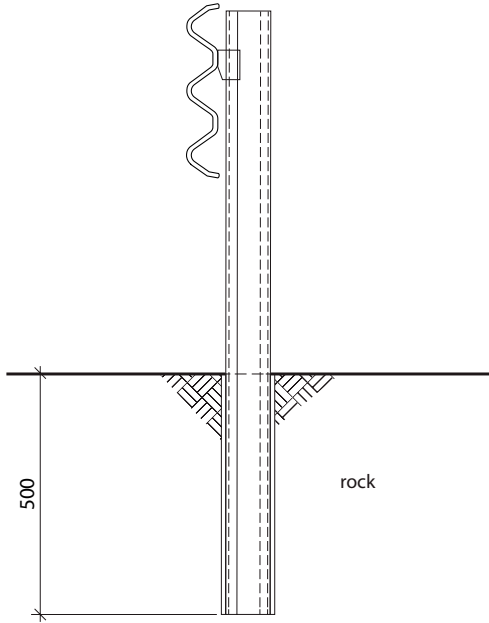
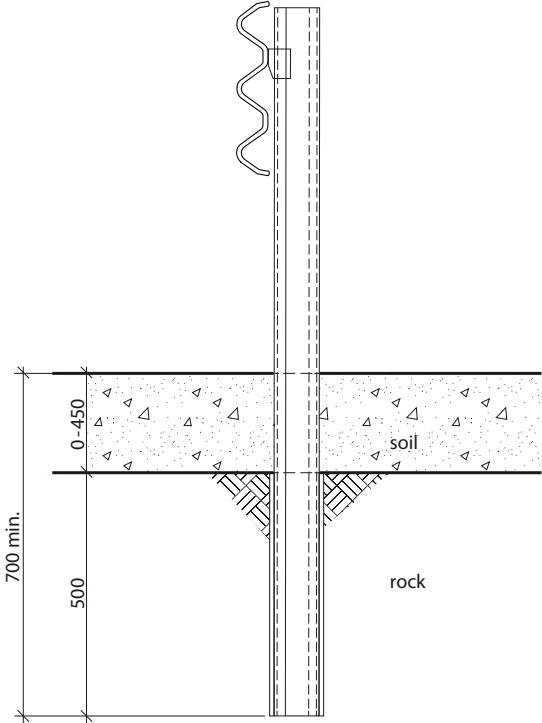
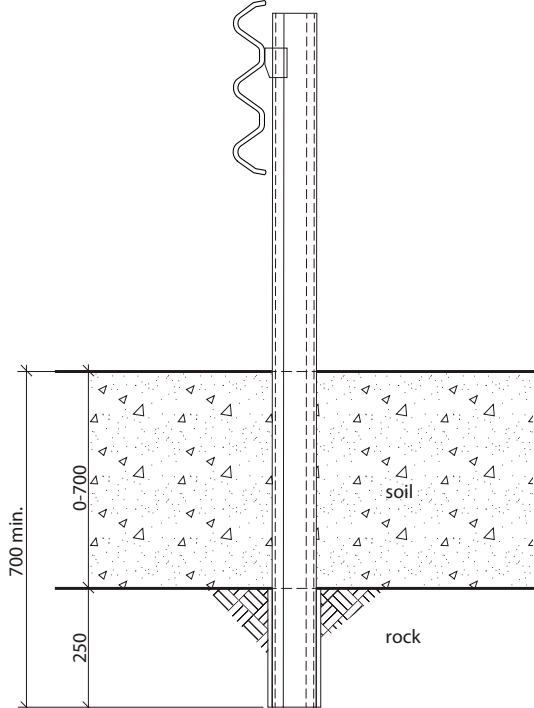
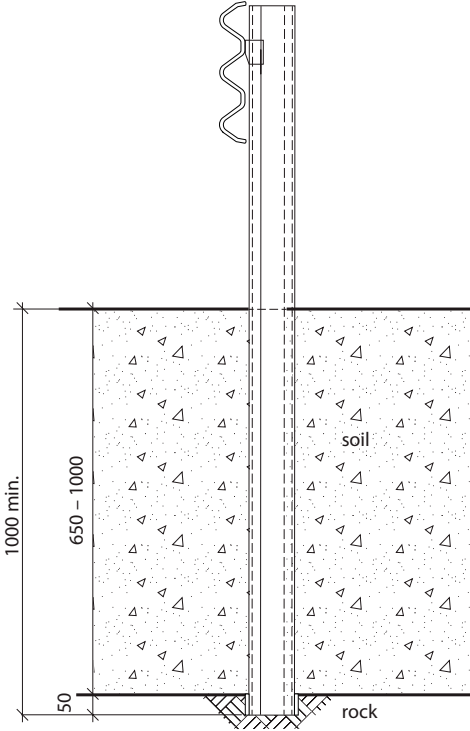

Figure 6: Minimum length measurement

**Table 2: Installation of Ezy-Guard HC Z-Posts in Rock**

Site Condition	Installation Requirements	
<p>Rock is encountered at the surface.</p>	<p>Drill a 160-300mm diameter hole to a depth of 500mm, install the post in the hole and backfill.</p>	
<p>Rock is encountered within 450mm of the surface.</p>	<p>Drill a 160-300mm diameter hole 500mm into the rock or to a minimum total post embedment depth of 700mm, whichever comes first, install the post and backfill.</p>	

Site Condition	Installation Requirements	
<p>Rock is encountered 450mm to 650mm below ground.</p>	<p>Drill a 160-300mm diameter hole 250mm into the rock or to a minimum total post embedment depth of 700mm, whichever comes first, install the post and backfill.</p>	
<p>Rock is encountered 650mm to 1000mm below ground.</p>	<p>Drill a 160-300mm diameter hole 50mm into the rock or to a minimum total post embedment depth of 1000mm, whichever comes first, and install the post and backfill.</p>	

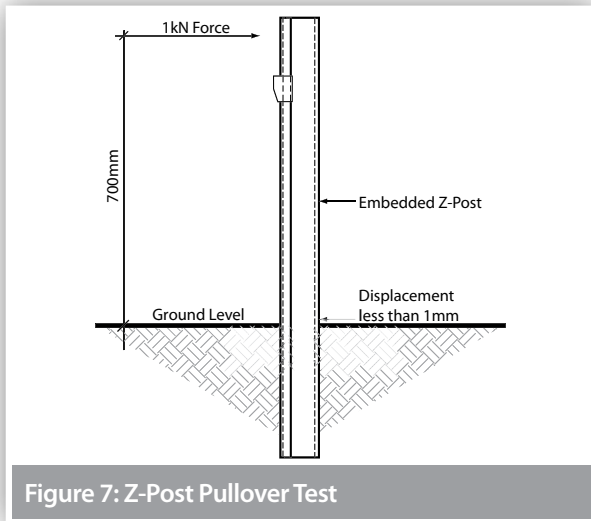

Figure 7: Z-Post Pullover Test

### 7.7 Posts on Base Plates

In the event that the Z-post cannot be installed to the required in-ground depth, the use of a base plate mounted post on a suitable foundation can be adopted. Posts on base plates are typically used at culvert locations, and in areas where underground services restrict posts from being driven into the ground. Refer to Ingal Civil Products drawings for the installation of posts on base plates and to your local Ingal representative for appropriate footing design conditions.

### 7.8 Barrier Offset From Kerb

The presence of kerbs in close proximity to a safety barrier, combined with the vehicle speed and kerb profile can dramatically influence the way an errant vehicle engages and interacts with the safety barrier. Extensive guidance on this topic is given in the Austroads Guide to Road Design Part 6, including the suitability of kerb profiles for various offsets and speeds.

As a general principle, it is preferable that surface conditions in front of and beneath a safety barrier should be relatively flat. Where this is not possible due the presence of a semi-mountable kerb and a barrier has been deemed appropriate, it is recommended the Ezy-Guard HC system be installed with its height measured from back of kerb, i.e. 980mm to top of Thrie-Beam.

### 7.9 Non-Standard Post Spacing

Occasionally, an underground services or obstruction may prevent a post from being installed at the recommended spacing. In these instances, there are a number of options:

- Do not install the post and leave a 4m gap. This will result in a higher deflection if impacted in that location. This is permissible for no more than one location in 30m of Ezy-Guard HC.
- If the underground conflict is short in length, the post can be moved 1m upstream or downstream from the original position. Special rails are available from Ingal with

slots at 1m intervals. Alternatively, the rail can be drilled to take the M16 carriage bolt. The drilled hole should have the galvanized coating repaired in accordance with section 7.4.

- A concrete foundation can be installed and a post on baseplate can be anchored to the foundation. Refer section 7.7 for further details.

### 7.10 Curving of Rails

Guardrail used for the assembly of Ezy-Guard HC may be shop curved to fit any radius from 2.4m to 45m Convex.

Ezy-Guard HC for Concave Curves can be used from 2.4m to 45m. Curves in excess of 45m do not require shop curving as the rail can be field installed to suit. Guardrail may be curved either concave or convex to the traffic face and can be part-curved along its length to suit site requirements.

#### 7.10.1 Measuring Curvature

1. Mark along the arc of the curve at 4m intervals.
2. Measure the corresponding chord length (C) - refer to Figure 8.
3. Measure the corresponding centre offset (H) - refer to Figure 8.
4. Use the values for C & H to select the radius from Table 3.
5. Determine the curvature orientation from Figure 9.

#### 7.10.2 Identification of Curved Rails

Where a rail has been factory curved by Ingal, the radius of curvature is marked on the rear face of the rail.

Table 3: Rail Curvature Values

Radius (m)	Ø Degrees	C (mm)	H (mm)
2.4	95	3553	786
3	76	3710	642
4	57	3835	490
5	45	3894	395
6	28	3926	330
7	33	3946	284
8	29	3958	249
9	26	3967	221
10	23	3973	199
12	19	3982	166
14	16	3986	143
16	15	3990	125
20	12	3993	100
24	10	3995	83
28	8	3997	71
32	7	3997	62
35	7	3998	57
40	5	3998	50
45	5	3999	44

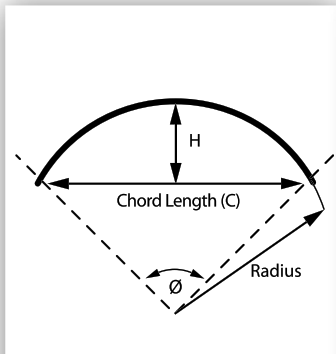

**Figure 8:**  
Curvature Measurements

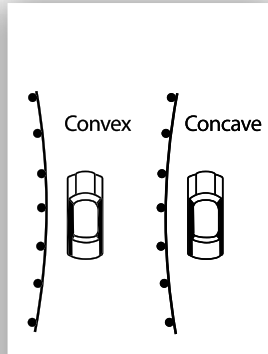

**Figure 9:**  
Curvature Orientation

### 7.11 Installation Sequence

The following written instructions should be read in conjunction with Ingal Civil Products' drawings.

A generic Safe Work Method Statement is available from Ingal Civil Products to assist in the safe installation of Ezy-Guard HC.

Only items purchased from Ingal Civil Products shall be used for the construction of Ezy-Guard HC.

1. Ensure the area has been inspected for underground hazards and that suitable traffic control is in place.
2. Post locations are marked ensuring any fixed object hazard to be protected is located outside the expected dynamic deflection of the barrier.
3. The post in relation to the direction of traffic is orientated as per Figure 10 and 11.

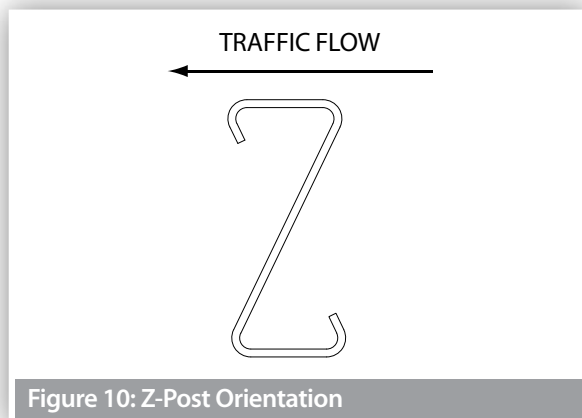

**Figure 10: Z-Post Orientation**

4. Posts are driven directly into the ground and should be vertical. The post installation process shall not cause damage to the post, such that it reduces the effective operation of the safety barrier or its design life, or introduces sharp tearing edges, nor shall it cause damage to pavement. If the Ezy-HC-Carriage cannot freely move as it is attached to the post as a result of deformation of the post during installation, then the post shall be replaced. The use of a vibrating post hammer will reduce deformation to the top of the post and install the post at a controlled rate.

5. Alternate to driving the posts, a minimum 200-300mm hole can be augured and the post placed in the hole. The posthole is then backfilled with the material that was excavated. If installing in soil, the material should be placed in layers of 150mm and suitably compacted to not less than the density of the surrounding layers.
6. Posts are spaced at 2m – 1,905mm spacings are required on transitions to w-beam - and reduced spacings are required where requested by engineer.
7. The height of the Z-post above ground level is 970mm.
8. The Ezy-HC-Carriage is attached to the face of the post. The Ezy-HC-Carriage will come to rest on the positioning lug fabricated on the Z-post.

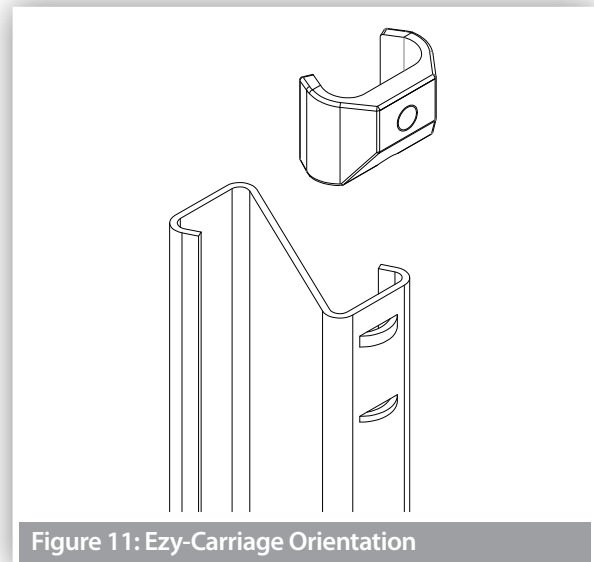

**Figure 11: Ezy-Carriage Orientation**

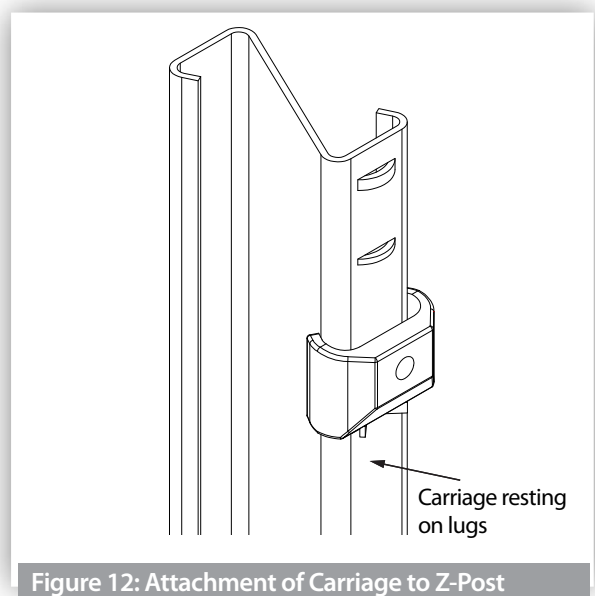

**Figure 12: Attachment of Carriage to Z-Post**

9. Rails are attached to the Ezy-HC-Carriage using the M16x30mm carriage bolts. The post bolts are identified by the socket recess located in the head of the bolt. The bolts are tightened to snug tight using a 10mm hex. key.
10. Rails are spliced together at every second post using M16x32mm mushroom head bolts and oversized nuts. There are 12 bolts required per splice connection. A pinch bar may be used to assist in the alignment of splice holes. The use of a driving pin to elongate the slots is NOT to be used since this may cause tearing of the rail at the slot location. The bolts are tightened to snug tight.

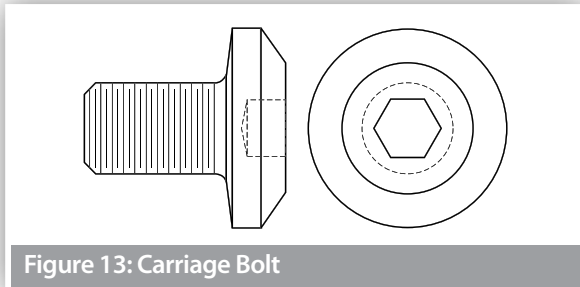

Figure 13: Carriage Bolt

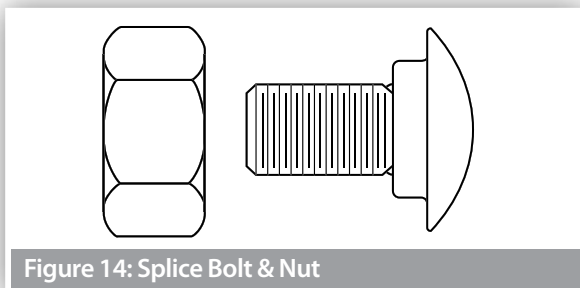

Figure 14: Splice Bolt & Nut

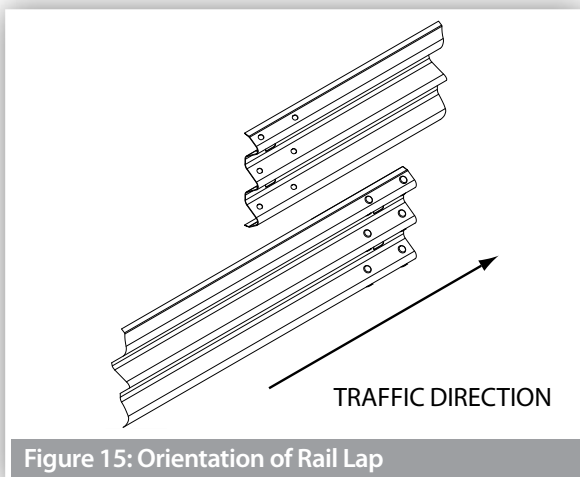

Figure 15: Orientation of Rail Lap

11. Rails are orientated so that no leading edge is presented to the traffic face as shown in Figure 15.
12. It is recommended that posts be installed only a few metres ahead of rail assembly to ensure correct post spacing and alignment. On curves, the rails can be used as a template and laid on the ground to determine post locations.
13. The construction of Ezy-Guard HC shall form a smooth line vertically and horizontally when viewed along the line of the system, free from humps, sags or other irregularities.
14. The Ezy-Guard HC components are to be free from splits, burrs or sharp edges after installation. Any minor damage is to be repaired in accordance with section 7.4.
15. Any disturbed pavement or material around a post shall be left dense, tight, and smooth so that resistance to water penetration is similar to that of the adjacent surface.

#### 7.12 Installation Tolerances

- The tolerance on height of the barrier shall be plus or minus 20mm.
- The tolerance for the line of the barrier shall be plus or minus 20mm in plan view.
- The tolerance for departure from the upright axis shall be plus or minus 15mm at the top of the barrier.
- The tolerance on post spacing shall be plus or minus 25mm.

#### 8.0 Maintenance

It is recommended that annual inspections be performed to ensure the following;

- The system is appropriately delineated;
- Debris has not accumulated around the system that may impede the performance of the barrier or the trajectory of an impacting vehicle;
- The system is suitably anchored with appropriate terminals and/or transitions. If the system is anchored with terminals, the cable assembly shall be taut and tensioned to its recommended value; and
- All splice bolts and post bolts are snug tight.

#### 9.0 Product Storage

All posts and rails are hot dip galvanized in accordance with AS/NZS 4680. It is important that stored galvanized work is stacked so that each item is well ventilated and can adequately drain rainwater from its surfaces.

Poor storage can give rise to wet storage stain (white rust) which is caused by water (rain or condensation) in badly drained or ventilated conditions. This can occur very quickly, particularly in warm, humid conditions.

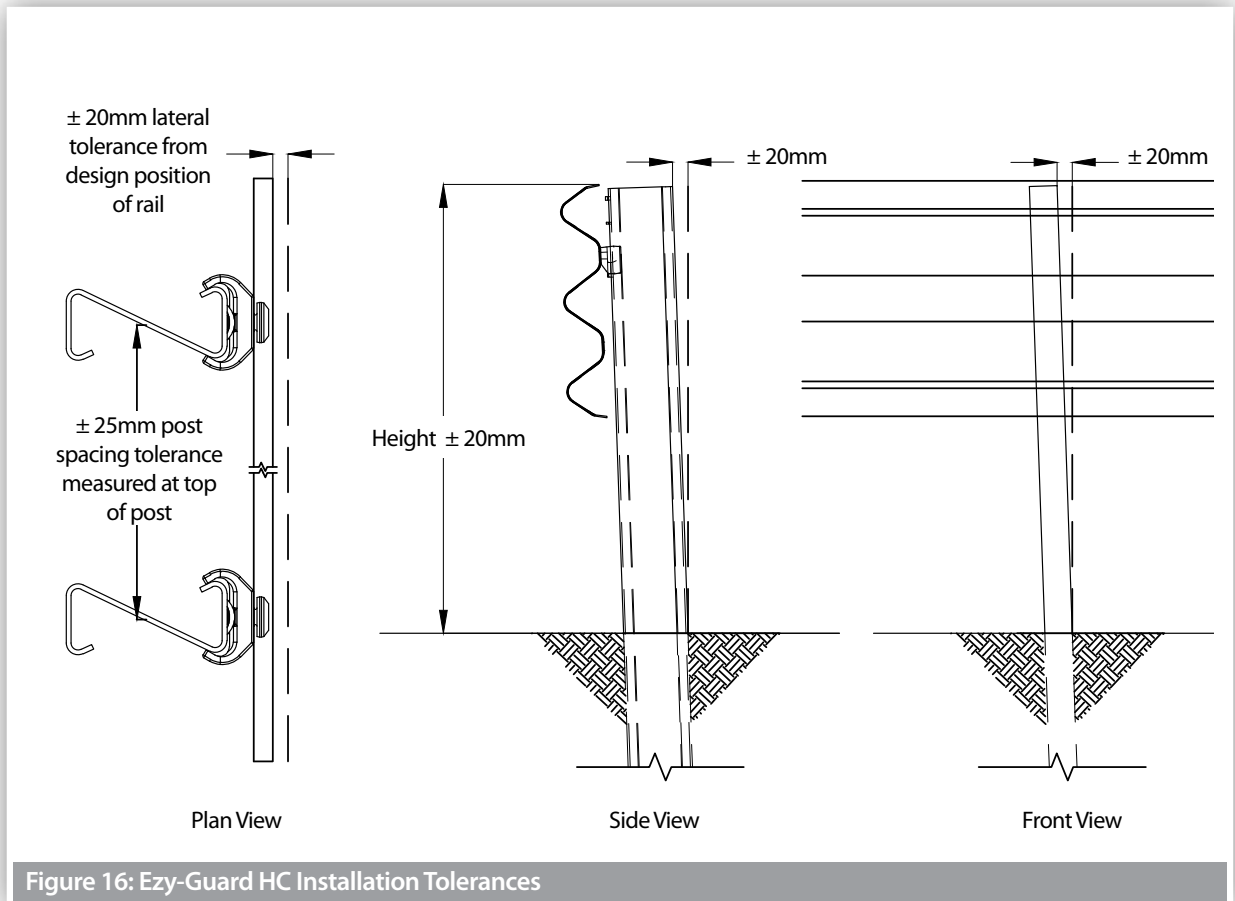





### Ezy-Guard HC Installation Checklist

Customer:

Project:

Barrier ID:

Barrier Length:

Checked By:

Signed:

Date

Have the HC Z-posts been positioned every 2m	<input type="checkbox"/> Yes	<input type="checkbox"/> No
Carriages are positioned on the posts between the retaining lugs and the resistance tabs	<input type="checkbox"/> Yes	<input type="checkbox"/> No
Posts are installed to the correct height (970mm) and within the tolerances of section 7.12	<input type="checkbox"/> Yes	<input type="checkbox"/> No
Have the Ezy-HC-Carriages been correctly orientated	<input type="checkbox"/> Yes	<input type="checkbox"/> No
Have the rails been attached to the Ezy-HC-Carriages using the appropriate carriage bolt	<input type="checkbox"/> Yes	<input type="checkbox"/> No
Have the rails been spliced observing the correct lap	<input type="checkbox"/> Yes	<input type="checkbox"/> No
Have the rails been spliced with M16x32mm mushroom head bolts	<input type="checkbox"/> Yes	<input type="checkbox"/> No
Are all splice bolts and post bolts snug tight	<input type="checkbox"/> Yes	<input type="checkbox"/> No
Is the Ezy-Guard HC attached to suitable transition rails then anchored with approved terminals	<input type="checkbox"/> Yes	<input type="checkbox"/> No
Are the cables in the terminals tensioned to their nominated torque (taut) where required	<input type="checkbox"/> Yes	<input type="checkbox"/> No
Has any minor damage been repaired using two coats of an organic zinc rich paint	<input type="checkbox"/> Yes	<input type="checkbox"/> No
Does the barrier form a smooth line vertically and horizontally when viewed along the system	<input type="checkbox"/> Yes	<input type="checkbox"/> No
Is the barrier system free from humps, sags or other irregularities	<input type="checkbox"/> Yes	<input type="checkbox"/> No
Is the fill material around each post suitably compacted and level	<input type="checkbox"/> Yes	<input type="checkbox"/> No
Are the barrier components free from splits, burrs or sharp edges after installation	<input type="checkbox"/> Yes	<input type="checkbox"/> No

#### Surface Mount Variant:

Are the footing dimensions as per EZY-HC-009	<input type="checkbox"/> Yes	<input type="checkbox"/> No
Are anchoring options as per EZY-HC-009, note 6	<input type="checkbox"/> Yes	<input type="checkbox"/> No

#### Disclaimer:

Important Note: The conformity of the installation is the responsibility of the installation contractor, and Ingal Civil Products accepts no liability for or in connection with any installation that is outside of the specifications of this manual or the NZTA. For more information, please refer to our Standard Terms and Conditions of Sale available on our website: [www.ingalcivil.co.nz](http://www.ingalcivil.co.nz).

## 10.0 Repair

### 10.1 Bush Fire Damage

Ezy-Guard HC does not contain any plastic, timber or rubber components that will burn.

The performance of galvanised coatings when subjected to fires depends upon a number of factors, such as flame duration and intensity.

Typical bushfire conditions may expose steel structures to an air temperature of 800°C for periods of up to 120 seconds, however zinc coatings are generally reflective and will not absorb heat at the same rate as an uncoated steel surface. Depending on the section thickness of the steel, the actual steel surface temperature may not exceed 350°C.

Typically, the bushfire flame duration and intensity are not high enough to compromise the structural strength of the steel. The hot dip galvanized coating will also typically remain unaffected through a bushfire event. If the bushfire causes damage to the galvanized surface, then the item(s) shall be replaced.

### 10.2 Damage Assessment

In the event of a vehicle impact, damage to the barrier is to be assessed in accordance with Table 4.

A Safe Work Method Statement is available from Ingal Civil Products upon request to assist in the safe repair of Ezy-Guard HC.

Any item that is replaced is to be reinstated observing the installation tolerances nominated in Section 7.11. Only items purchased from Ingal Civil Products shall be used for the repair of Ezy-Guard HC.

### 10.3 Dismantling Sequence

Prior to undertaking dismantling due to a vehicle impact, the area should be assessed for hazards. These include trip hazards, sharp edges and snag points.

During a vehicle impact, the rail will disengage from the posts as they yield by bending at ground level. The recommended dismantling sequence is as follows;

1. Dismantle the rail splice by removing the M16x32mm mushroom head bolts and nuts. There are 8 bolts located at each splice location.
2. Rails that are still attached to posts outside the impact area are disconnected by removing the carriage bolts. A 10mm hex key is required.
3. Once the area is clear of damaged rail, the posts can be removed. Since the posts yield by bending near ground level, a sling or chain can be attached below the bent section.
4. The damaged post can be lifted using a backhoe or post extractor attachment.
5. Any disturbed pavement material shall be left dense, tight, and smooth prior to the installation of replacement posts.
6. Rails, posts and carriages to be disposed of, should be recycled at a ferrous scrap recycling facility.

**Table 4: Damage Assessment of Ezy-Guard HC**

Type of Defect	Description of the Defect	Action to be Taken
Galvanizing damage on Z-Posts.	The sum total of the damaged area does not exceed 35cm <sup>2</sup> (0.5% of the total surface area). The sum total of the damaged area exceeds 35cm <sup>2</sup>	An organic zinc rich epoxy paint is to be applied to the repair area in two coats as per section 7.4. The Z-post is to be replaced.
Galvanizing damage on rails.	The sum total of the damaged area does not exceed 200cm <sup>2</sup> (0.5% of the total surface area) and no individual damaged area does not exceed 40cm <sup>2</sup> . The sum total of the damaged area exceeds 200cm <sup>2</sup> (0.5% of the total surface area) and/or an individual damaged area exceeds 40cm <sup>2</sup> .	An organic zinc rich epoxy paint is to be applied to the repair area in two coats as per section 7.4. The rail is to be replaced.
Mechanical damage on Ezy-HC-Carriages.	The Ezy-HC-Carriage has chips or cracks.	The Ezy-HC-Carriage is to be replaced.
Mechanical damage on Z-Posts.	The post is bent. The Ezy-Carriage cannot travel freely along the post due to distortion.	The post is to be replaced. The post is to be replaced.
Mechanical damage on rail.	The rail is dented, twisted or flattened. There are tears in any part of the rail. The slots in the rail are distorted.	The rail is to be replaced. The rail is to be replaced. The rail is to be replaced.
Mechanical damage on bolts.	The body of the bolt is distorted. The thread of the bolt is damaged.	The bolt is to be replaced. The bolt is to be replaced.
Disturbance of material around posts	The material around the post is loose or uncompacted.	Any disturbed pavement or material around a post shall be left dense, tight and smooth so that resistance to water penetration is similar to that of the adjacent surface.

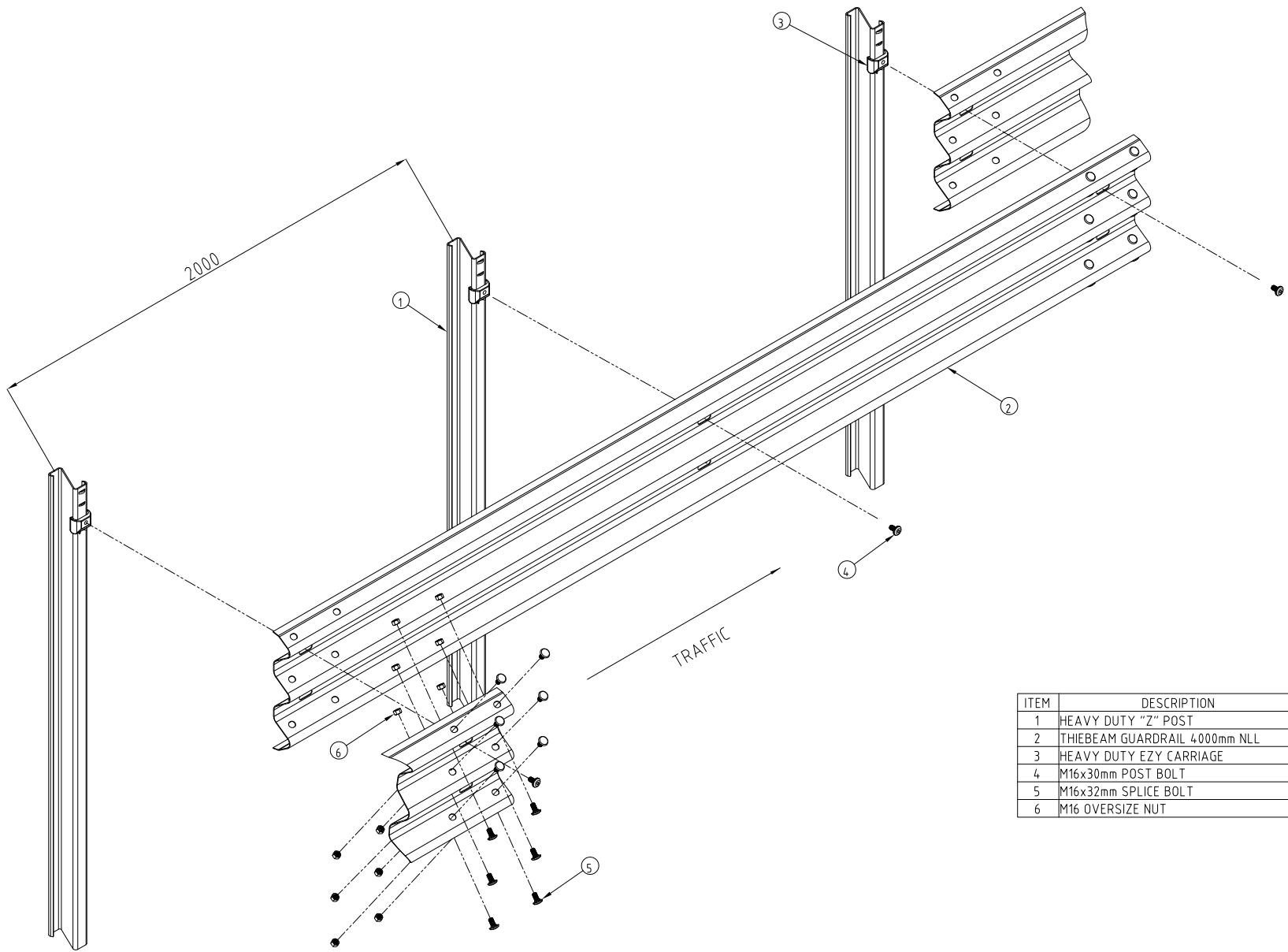

ITEM	DESCRIPTION
1	HEAVY DUTY "Z" POST
2	THIEBEAM GUARDRAIL 4000mm NLL
3	HEAVY DUTY EZY CARRIAGE
4	M16x30mm POST BOLT
5	M16x32mm SPLICE BOLT
6	M16 OVERSIZE NUT

REV	DATE	DESCRIPTION	DRAWN	CHECKED	APPROVED

DRAWING NUMBER	REFERENCE DRAWINGS

NAME	DATE
DRAWN AUSCOL	05-07-2016
CHECKED LG	12-07-2016
APPROVED LG	12-07-2016
SCALE N.T.S. @ A3	
ISSUE FOR	

**INGAL CIVIL PRODUCTS**  
A volmount COMPANY

DRAWING AND CONTENTS ARE COPYRIGHT TO INGAL CIVIL PRODUCTS AND CAN ONLY BE USED WITH PRIOR WRITTEN CONSENT FROM INGAL CIVIL PRODUCTS

57-65 AIRDS ROAD MINTO, N.S.W 2566 PH. +61 2 9827 3333 www.ingalcivil.com.au

PROJECT	TITLE
	EZY-GUARD HIGH CONTAINMENT ASSEMBLY DETAIL EXPLODED VIEW

INGAL CIVIL PRODUCTS PART No.	DRAWING No.
	EZY-HC-003

Rev: 0

J:\SALES & MARKETING\DRAWINGS\EZY-GUARD\HC\EZY-HC003 - EXPLODED ASSEMBLY.DWG

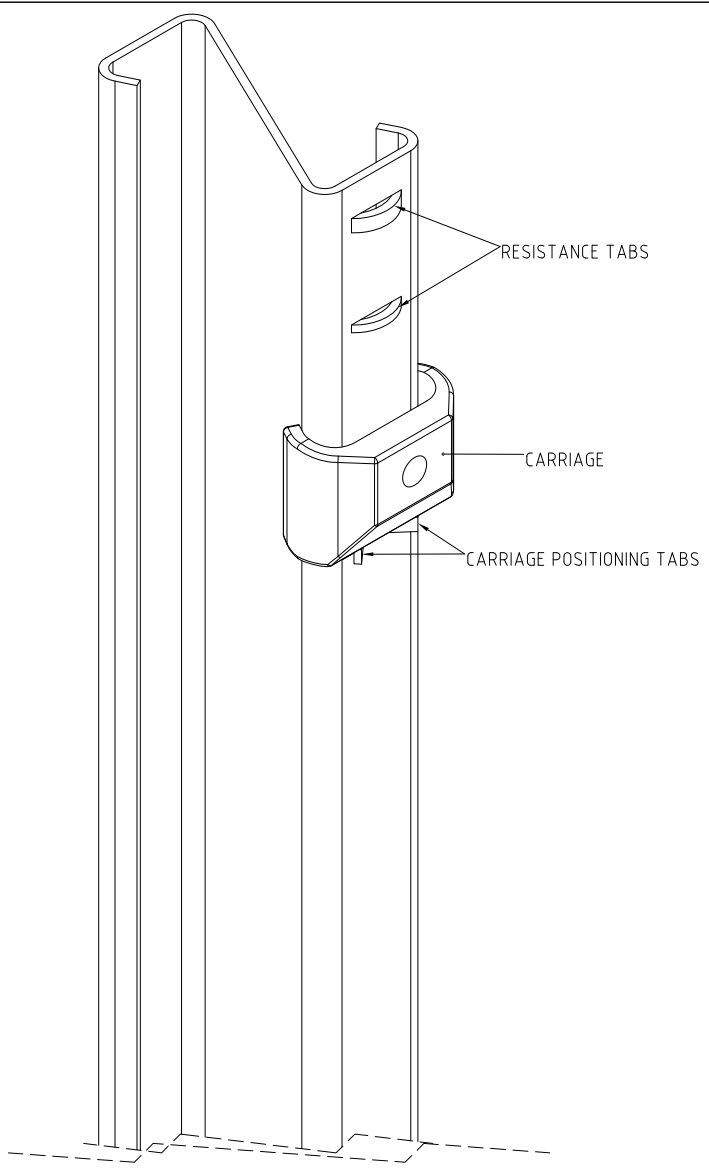

HC "Z" POST & CARRIAGE ASSEMBLY ISOMETRIC VIEW

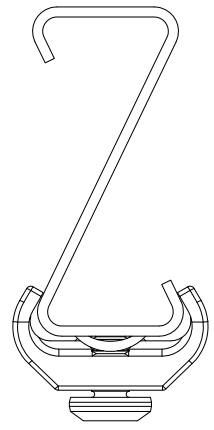

HC "Z" POST & CARRIAGE ASSEMBLY PLAN VIEW

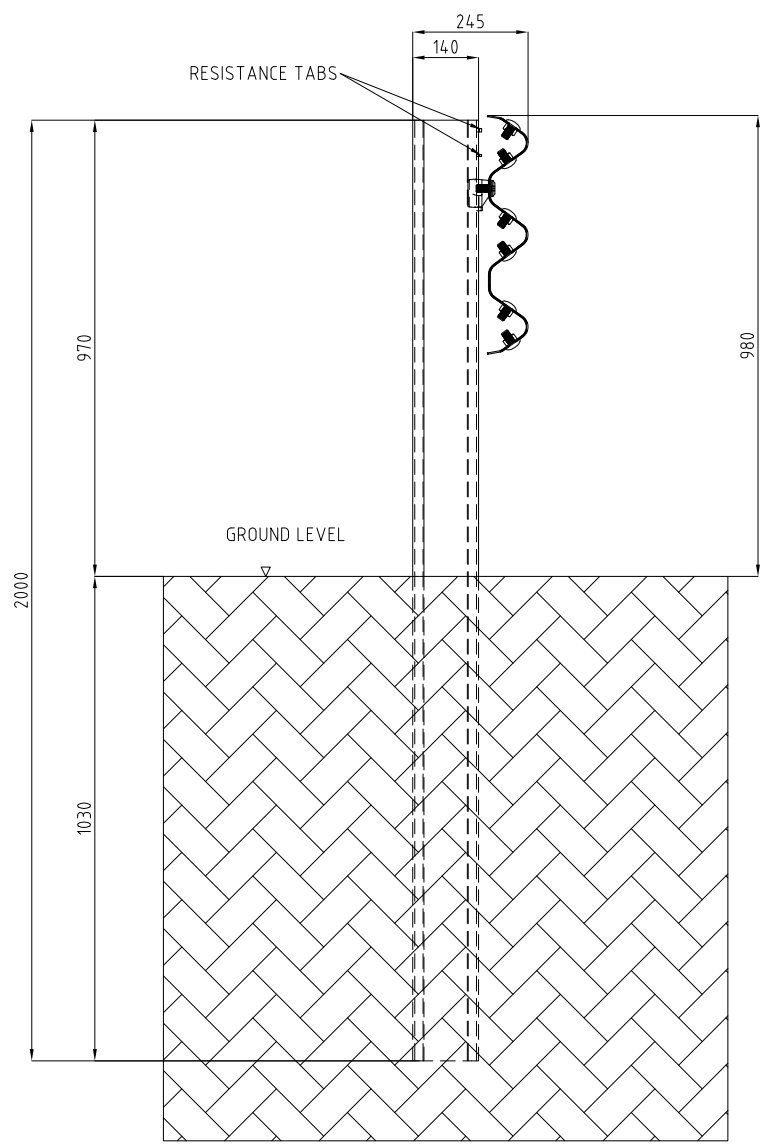

HC "Z" POST & CARRIAGE ASSEMBLY SIDE VIEW

REV	DATE	DESCRIPTION	DRAWN	CHECKED	APPROVED

REFERENCES	DRAWING NUMBER	REFERENCE DRAWINGS

NAME	DATE
DRAWN AUSCOL	05-07-2016
CHECKED MC	04-10-2016
APPROVED LG	04-10-2016
SCALE N.T.S. @ A3	
ISSUE FOR	

**INGAL CIVIL PRODUCTS**  
a valmont COMPANY

DRAWING AND CONTENTS ARE COPYRIGHT TO  
 INGAL CIVIL PRODUCTS AND CAN ONLY BE USED  
 WITH PRIOR WRITTEN CONSENT FROM INGAL CIVIL  
 PRODUCTS

57-65 AIRDS ROAD  
 MINTO, N.S.W. 2566

PH. +61 2 9827 3333  
 www.ingalcivil.com.au

PROJECT	TITLE
	EZY-GUARD HIGH CONTAINMENT POST CONFIGURATION DETAIL

INGAL CIVIL PRODUCTS PART No.	DRAWING No.
	EZY-HC-004

Rev: 0

J:\SALES & MARKET\DRAWINGS\EZY-GUARD\HC\EZY-HC004-POST CONFIGURATION.DWG

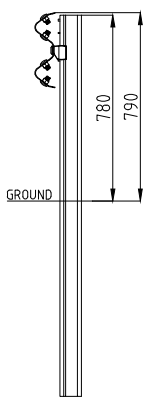
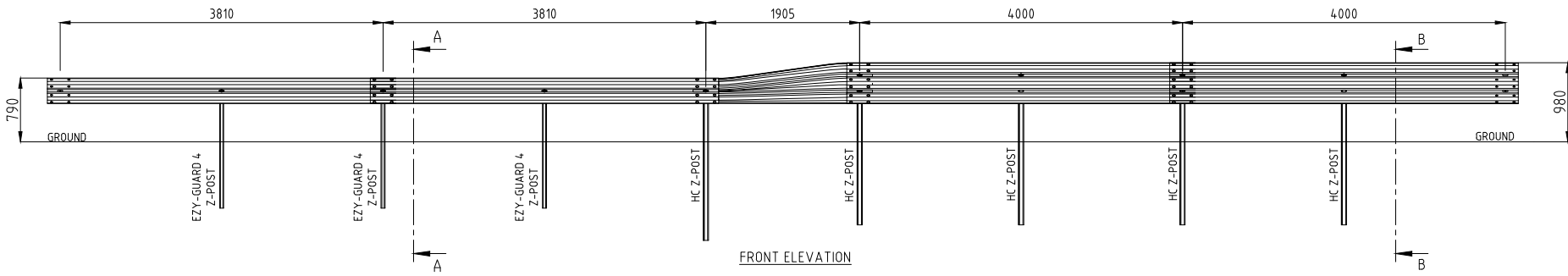
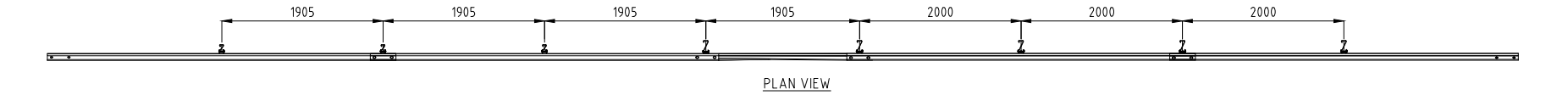

SECTION A-A

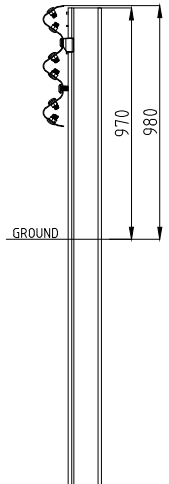

SECTION B-B

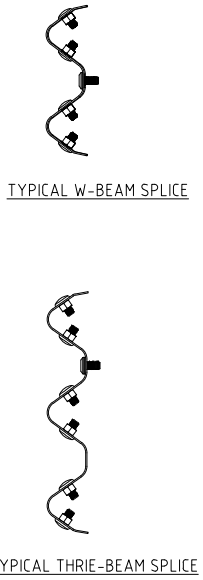

TYPICAL W-BEAM SPLICE

TYPICAL THRIE-BEAM SPLICE

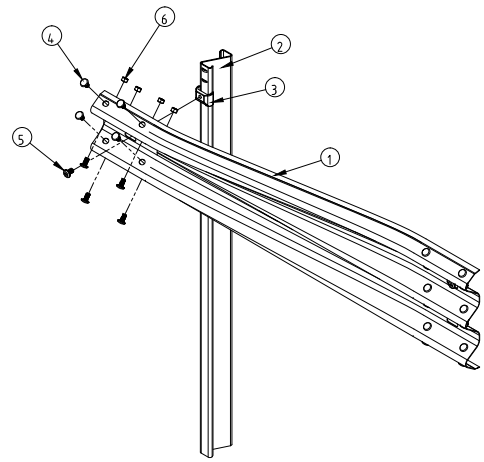

TRANSITION AND POST ASSEMBLY

REVISIONS			REFERENCES		
REV	DATE	DESCRIPTION	DRAWN	CHECKED	APPROVED
1	07-12-16	POST LABELS CORRECTED	MC	LG	LG

DRAWING NUMBER	REFERENCE DRAWINGS

NAME	DATE
DRAWN AUSCOL	05-07-2016
CHECKED LG	12-07-2016
APPROVED LG	12-07-2016
SCALE	N.T.S. @ A3
ISSUE FOR	

57-65 AIRDS ROAD  
MINTO, N.S.W. 2566  
PH. +61 2 9827 3333  
www.ingalcivil.com.au

PROJECT	TITLE
	EZY-GUARD HIGH CONTAINMENT TRANSITION DETAIL EZY-GUARD HC TO 790MM W-BEAM

INGAL CIVIL PRODUCTS PART No.	DRAWING No.
	EZY-HC-010

J:\SALES & MARKETING\DRAWINGS\EZY-GUARD-HC\EZY-HC010-NZ-TRANSITION.ASSIST.DWG

Rev: 1

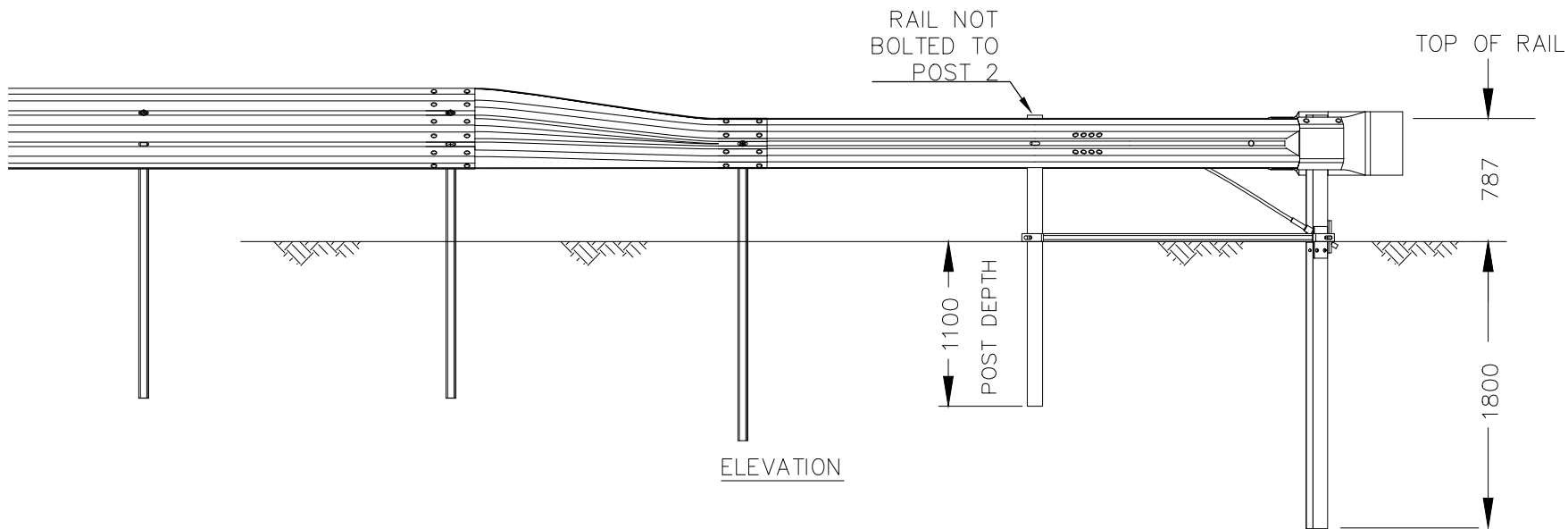
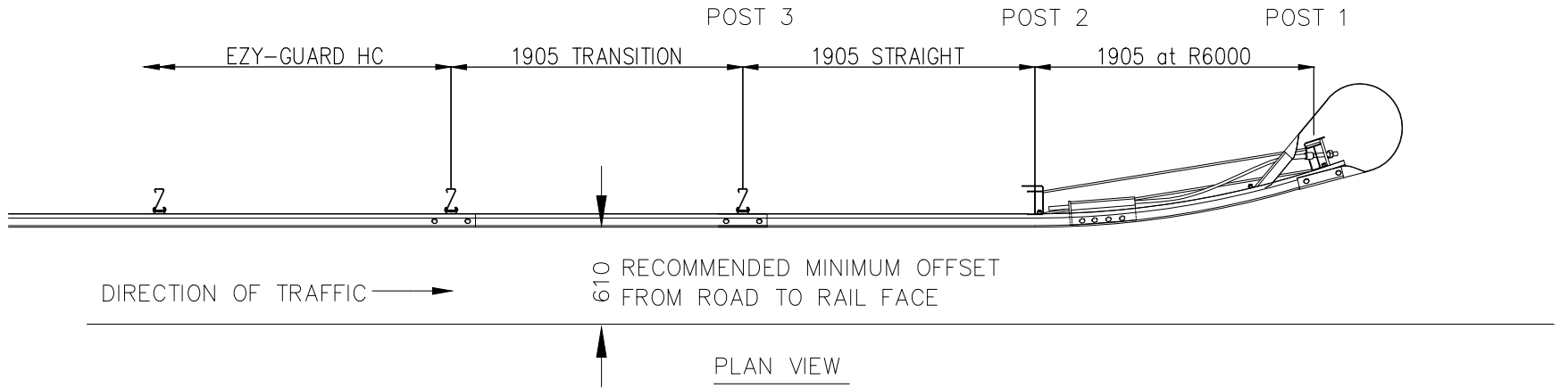

NOTE  
TRAILING TERMINAL TO BE USED IN DEPARTURE END OF SAFETY BARRIER ONLY.  
NOT TO BE USED WITHIN CLEAR ZONE OF OPPOSING TRAFFIC.

REVISIONS			REFERENCES			DRAWING INFORMATION			INGAL CIVIL PRODUCTS			
REV	DATE	DESCRIPTION	DRAWN	CHECKED	APPROVED	DRAWING NUMBER	REFERENCE DRAWINGS	SCALE	ISSUE FOR	NAME	DATE	TITLE
0		ORIGINAL ISSUE						N.T.S. @ A3	INFORMATION ONLY	MC	07-12-16	EZY-GUARD HIGH CONTAINMENT TRANSITION DETAIL EZY-GUARD HC TO NZ TRAILING TERMINAL
										LG	07-12-16	
										LG	07-12-16	
<p>DRAWING AND CONTENTS ARE COPYRIGHT TO INGAL CIVIL PRODUCTS AND CAN ONLY BE USED WITH PRIOR WRITTEN CONSENT FROM INGAL CIVIL PRODUCTS 57-65 AIRDS ROAD MINTO, N.S.W 2566 PH. +61 2 9827 3333 www.ingalcivil.com.au</p>												
<p>PROJECT: EZY-GUARD HIGH CONTAINMENT TRAILING TERMINAL DRAWING No. EZY-HC-011 Rev. 0</p>												

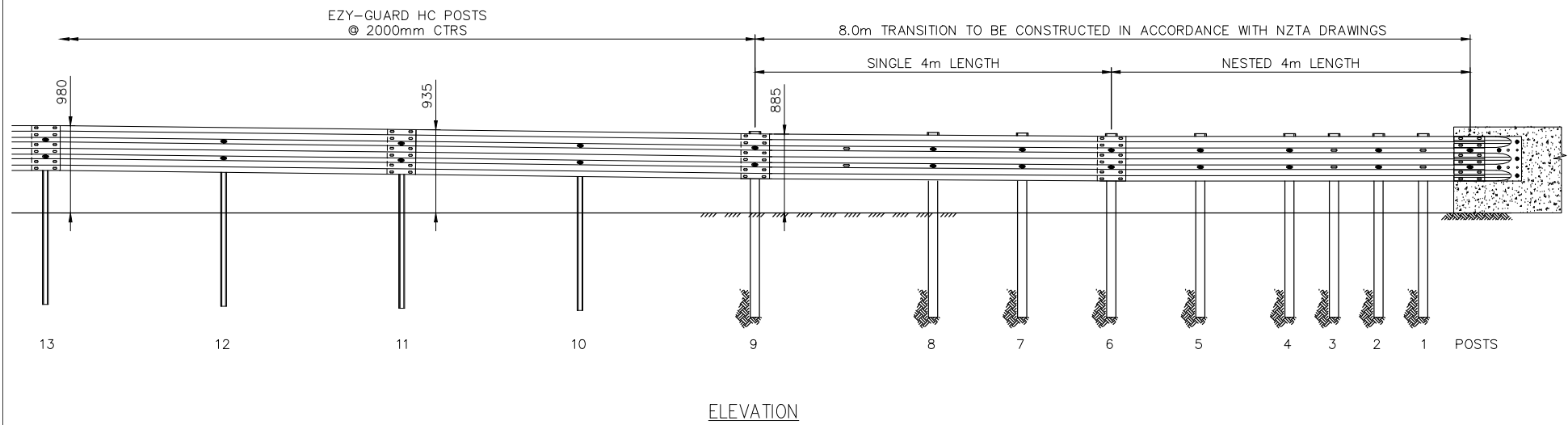
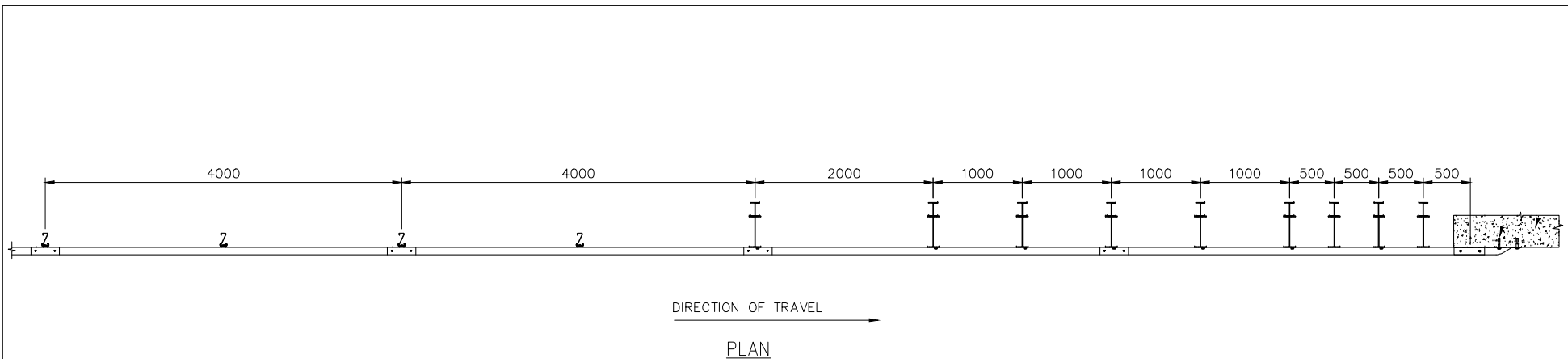

NOTES:  
 1. TO BE READ IN ACCORDANCE WITH NZTA DRAWING NO. RSB-5, POSTS 0-9 ONLY

REV	DATE	DESCRIPTION	DRAWN	CHECKED	APPROVED	DRAWING NUMBER	REFERENCE DRAWINGS	NAME	DATE	PROJECT	INGAL CIVIL PRODUCTS PART No.
0		ORIGINAL ISSUE						MC	23-01-17	<p>DRAWING AND CONTENTS ARE COPYRIGHT TO INGAL CIVIL PRODUCTS AND CAN ONLY BE USED WITH PRIOR WRITTEN CONSENT FROM INGAL CIVIL PRODUCTS</p> <p>57-65 AIRDS ROAD MINTO, N.S.W. 2566 PH. +61 2 9827 3333 www.ingalcivil.com.au</p>	
								LG	23-01-17		
								LG	23-01-17		
								N.T.S. @ A3			
										TITLE EZY-GUARD HIGH CONTAINMENT TRANSITION TO NZTA CONCRETE BARRIER	DRAWING No. EZY-HC-012
											Rev. 0

J:\SALES & MARKETING\DRAWINGS\EZY-GUARD HC\EZY-HC-012-NZTA CONC TRANSITION TO EZY-GUARD HC.DWG

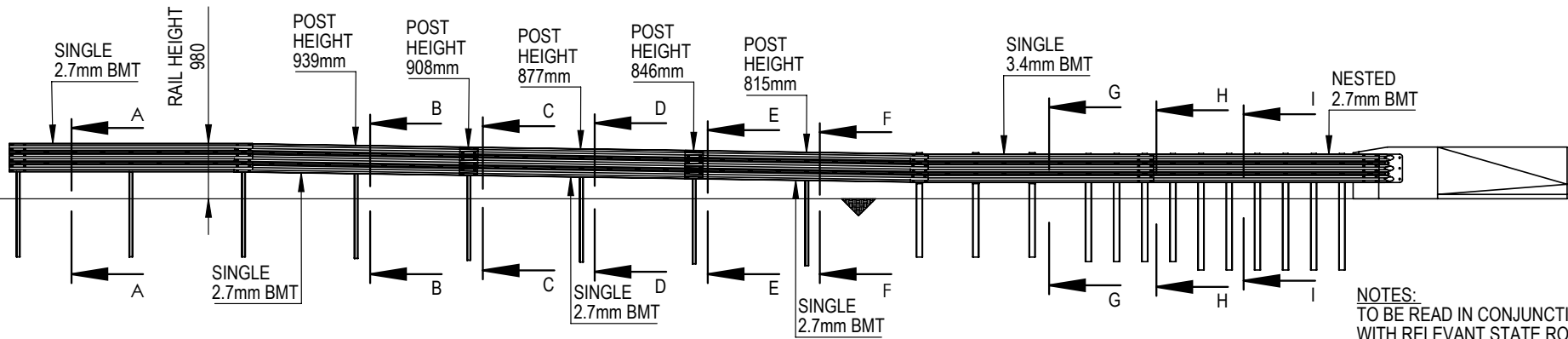
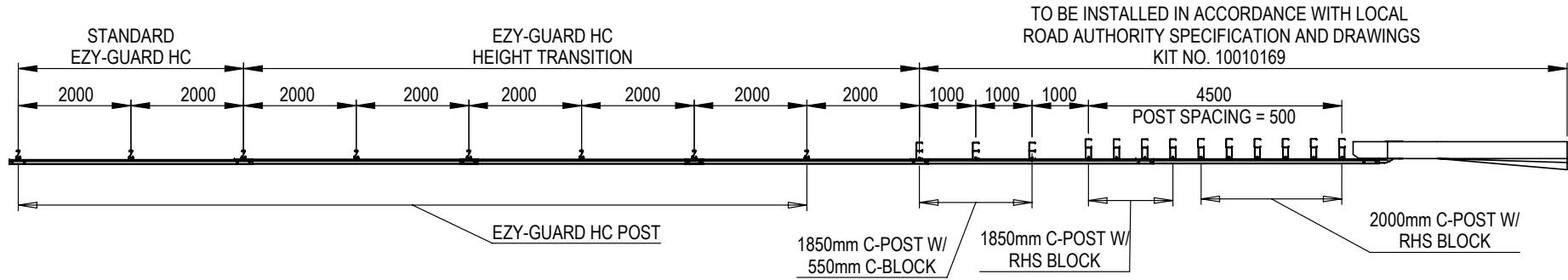

NOTES:  
TO BE READ IN CONJUNCTION  
WITH RELEVANT STATE ROAD  
AUTHORITY DRAWINGS AND  
SPECIFICATIONS

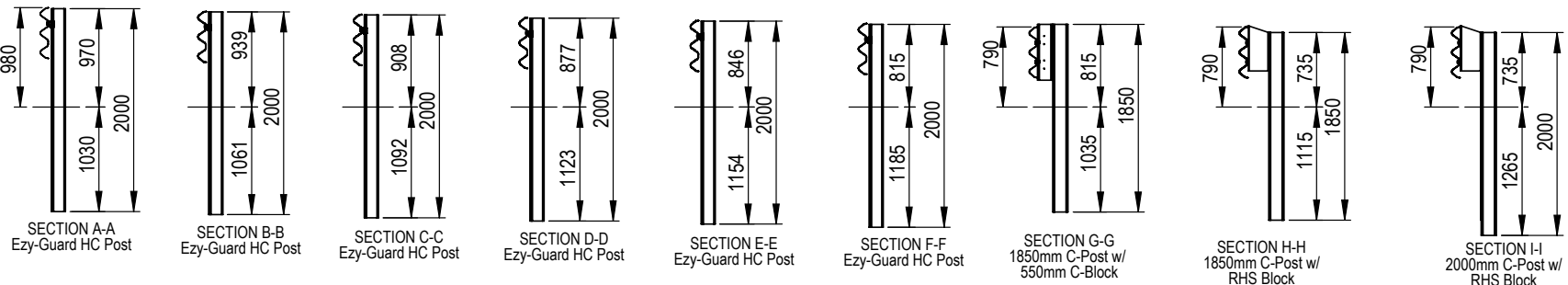

REV	DATE	DESCRIPTION	DRAWN	CHECKED	APPROVED	DRAWING NUMBER	REFERENCE DRAWINGS	SCALE	ISSUE FOR	NAME	DATE	PROJECT	TITLE	DRAWING NO.
								1:100				ASBAP TRANSITION	ASBAP TRANSITION TO EZY-GUARD HC	EZY-HC-020

INGAL CIVIL PRODUCTS  
A valmont company

DRAWING AND CONTENTS ARE COPYRIGHT TO  
INGAL CIVIL PRODUCTS AND CAN ONLY BE USED  
WITH PRIOR WRITTEN CONSENT FROM INGAL CIVIL  
PRODUCTS

SPRINGBROOK ROAD  
MUNTO, N.S.W. 2566  
PH: +61 2 9627 3333  
www.ingalcivil.com.au

FOLDER: E:\ENGINEERING\3. CURRENT DRAWINGS\COMPONENT DRAWINGS\SLDRWS\ SOLID MODEL\ASBAP TRANSITIONS

Rev. 0



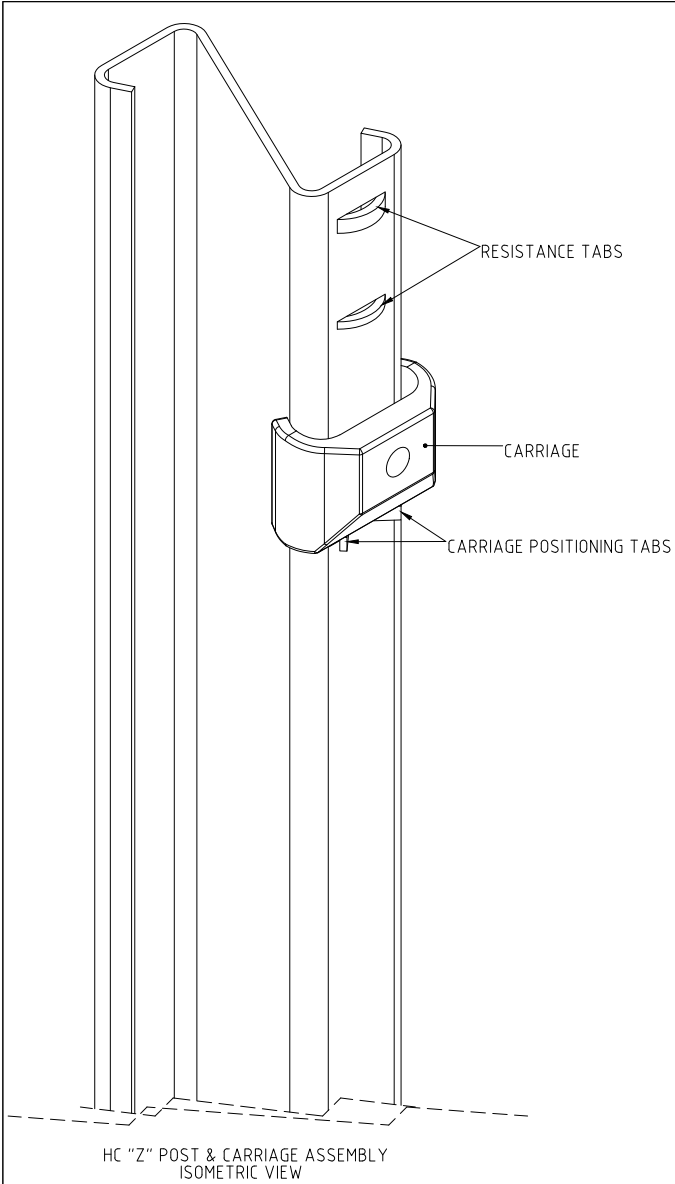

HC "Z" POST & CARRIAGE ASSEMBLY ISOMETRIC VIEW

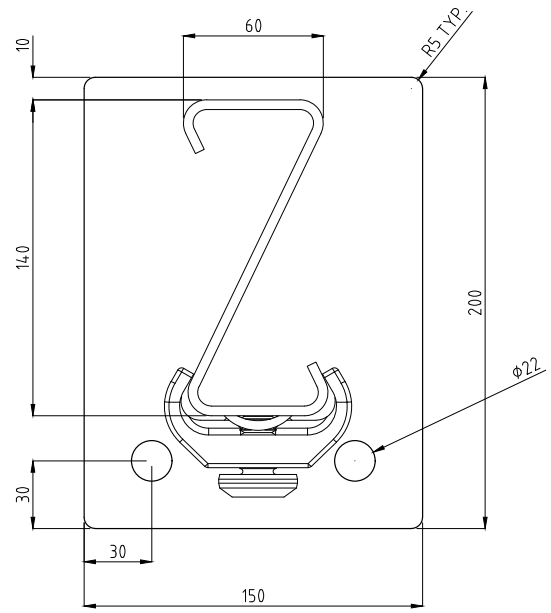

HC "Z" POST & CARRIAGE ASSEMBLY PLAN VIEW

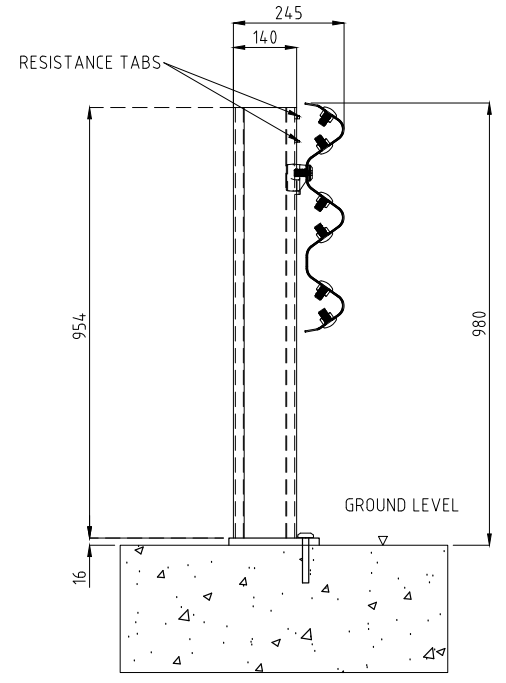

HC "Z" POST & CARRIAGE ASSEMBLY SIDE VIEW

REVISIONS			REFERENCES		
REV	DATE	DESCRIPTION	DRAWN	CHECKED	APPROVED
1	06/07/2016	BASEPLATE HOLES DIAMETER UPDATED	VB	LG	LG

DRAWING NUMBER	REFERENCE DRAWINGS

NAME	DATE
DRAWN MC	04-10-2016
CHECKED LG	04-10-2016
APPROVED LG	04-10-2016
SCALE N.T.S. @	A3
ISSUE FOR	

**INGAL CIVIL PRODUCTS**  
A valmont COMPANY

DRAWING AND CONTENTS ARE COPYRIGHT TO INGAL CIVIL PRODUCTS AND CAN ONLY BE USED WITH PRIOR WRITTEN CONSENT FROM INGAL CIVIL PRODUCTS

57-65 AIRDS ROAD  
MINTO, N.S.W 2566

PH: +61 2 9827 3333  
www.ingalcivil.com.au

PROJECT	TITLE
EZY-GUARD HIGH CONTAINMENT POST ON BASE PLATE CONFIGURATION DETAIL	EZY-GUARD HIGH CONTAINMENT POST ON BASE PLATE CONFIGURATION DETAIL

INGAL CIVIL PRODUCTS PART No.	DRAWING No.
	EZY-HC-006

J:\SALES & MARKETING\DRAWINGS\EZY-GUARD\HC\EZY-HC-006 - POST ON BASE PLATE CONFIGURATION.DWG

Rev 1

Guardrail System	Containment Level	Deflection*	Permanent Deflection*
Ezy-Guard HC	MASH TL4	1.2m	1.1m
	MASH TL3	1.16m	0.70m
	NCHRP-350 TL4	1.0m	0.60m

\* DEFLECTION MEASURED FROM FACE OF RAIL ON IMPACT SIDE.

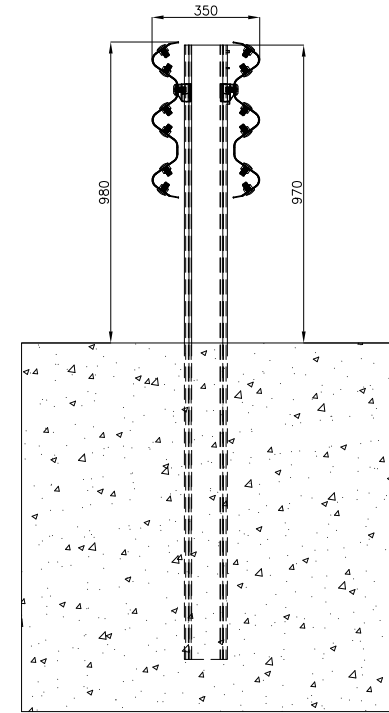
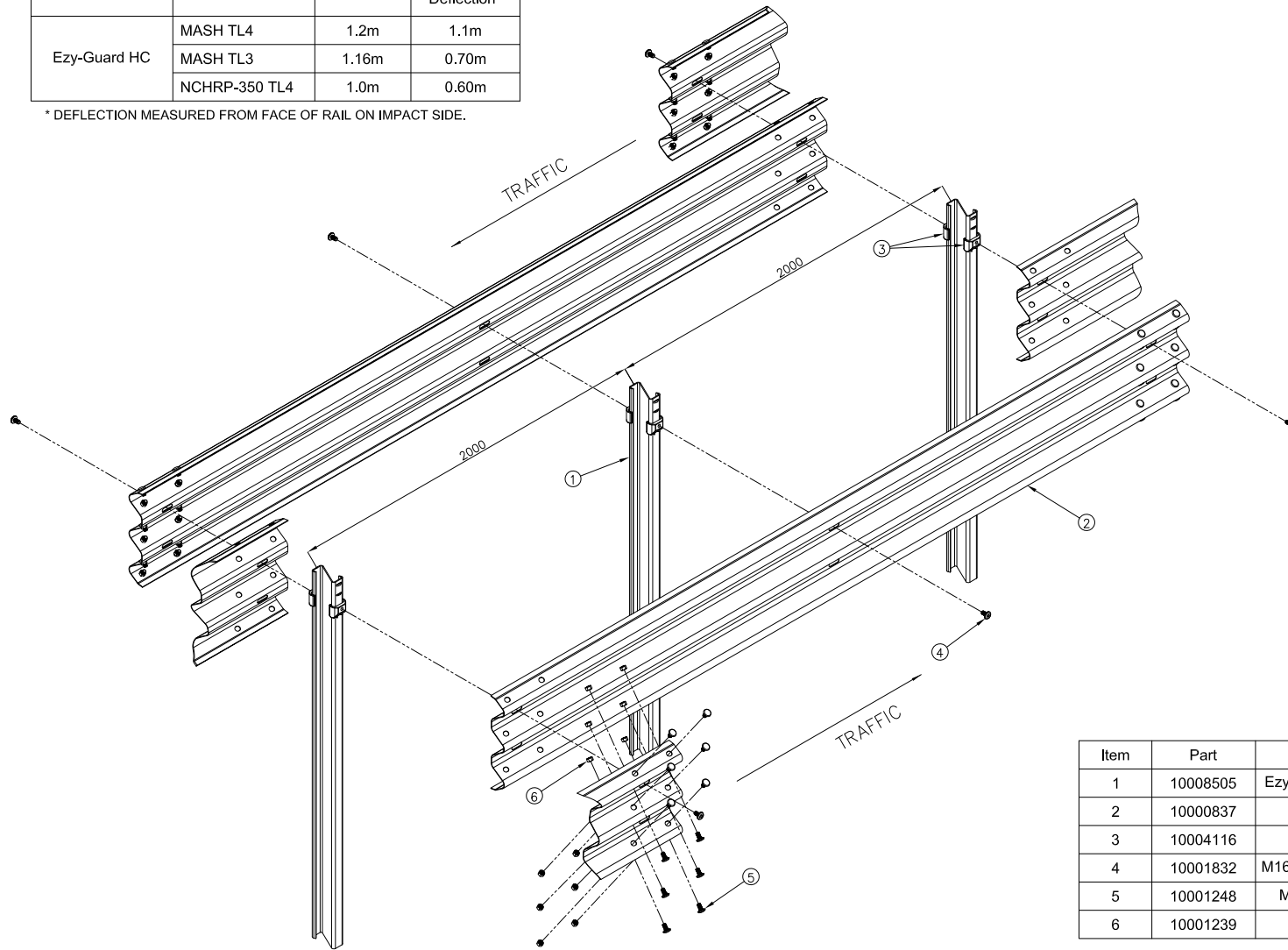

Item	Part	Description	Qty
1	10008505	Ezy-Guard HC Median Z-Post 2000mm	2
2	10000837	Thribeam (2.7) 4000mm NLL	2
3	10004116	Heavy Duty Carriage	4
4	10001832	M16 x 30mm Ezy-Guard Smart post bolt	4
5	10001248	M16 x 32mm Splice Bolt Grade 8.8	24
6	10001239	M16 Oversized Nut	24

REV	DATE	DESCRIPTION	DRAWN	CHECKED	APPROVED	DRAWING NUMBER	REFERENCE DRAWINGS	NAME	DATE	PROJECT	INGAL CIVIL PRODUCTS PART No.	
4	15-08-2022	DEFLECTION UPDATE	HZ	LG	LG			A.R.	04/04/18	 DRAWING AND CONTENTS ARE COPYRIGHT TO INGAL CIVIL PRODUCTS AND CAN ONLY BE USED WITH PRIOR WRITTEN CONSENT FROM INGAL CIVIL PRODUCTS 57-65 AIRDS ROAD MINTO, N.S.W 2566 PH. +61 2 9827 3333 www.ingalcivil.com.au	EZY-GUARD-HC BACK TO BACK CONFIGURATION ASSEMBLY DETAIL	
3	21-10-2021	PART NUMBER UPDATE	LG					W.D.	04/04/18			DRAWING No.  EZY-HC-017
2	04/03/2020	TABLE OF COMPONENTS UPDATED	VB	LG	LG			L.G.	04/04/18			
1	11/02/2020	DEFLECTIONS TABLE ADDED	VB	LG	LG			N.T.S. @	A3			
								ISSUE FOR	INFORMATION ONLY			
										Rev 4		

J:\S&LES & MARKET\DRAWINGS\EZY-GUARD\HC\EZY-GUARD-HC-BB-EXPLODED-ASSEMBLY DETAIL.DWG

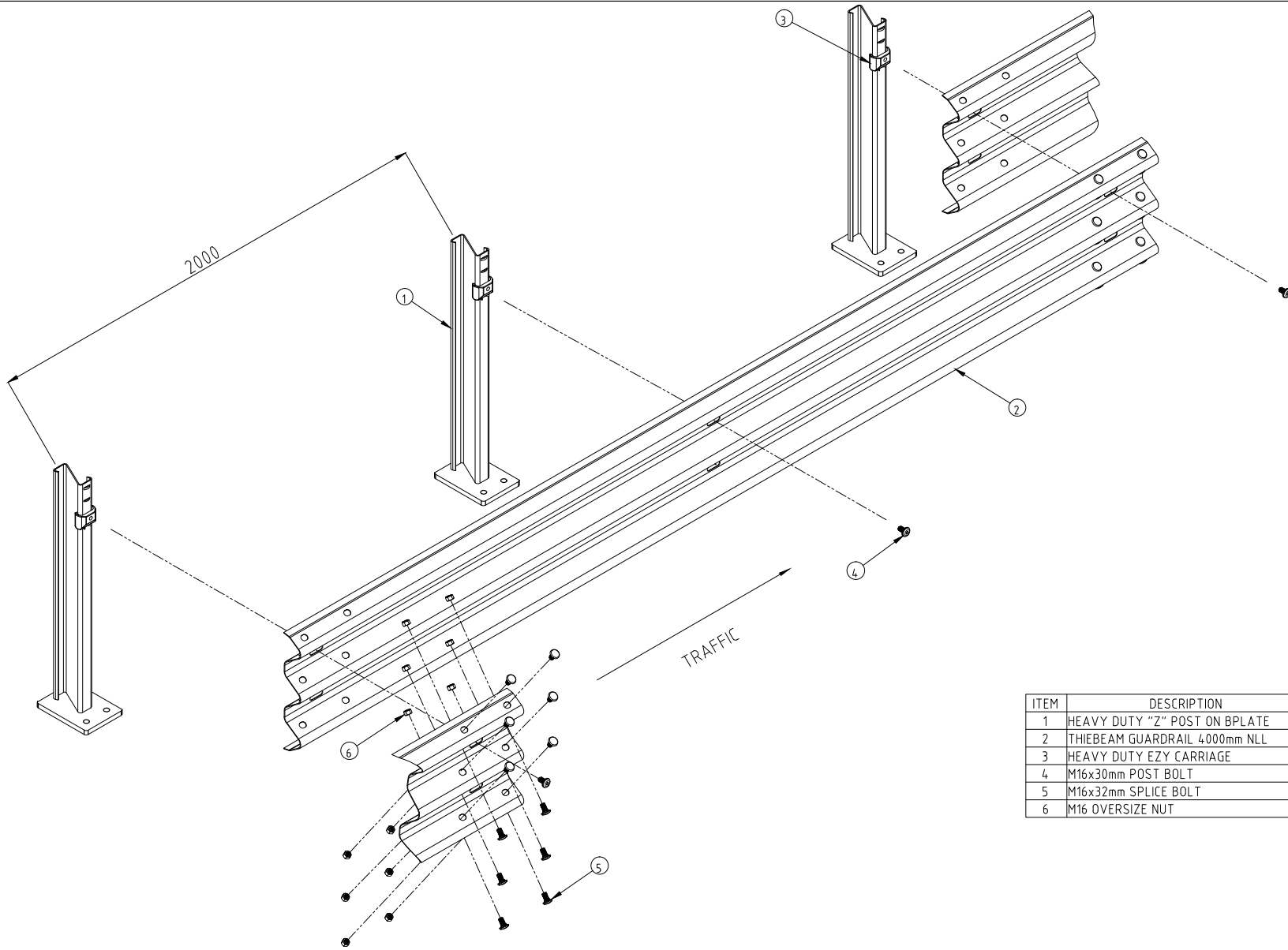

ITEM	DESCRIPTION
1	HEAVY DUTY "Z" POST ON BPLATE
2	THIEBEAM GUARDRAIL 4000mm NLL
3	HEAVY DUTY EZY CARRIAGE
4	M16x30mm POST BOLT
5	M16x32mm SPLICE BOLT
6	M16 OVERSIZE NUT

REV	DATE	DESCRIPTION	DRAWN	CHECKED	APPROVED

DRAWING NUMBER	REFERENCE DRAWINGS

NAME	DATE
DRAWN AUSCOL	05-07-2016
CHECKED LG	12-07-2016
APPROVED LG	12-07-2016
SCALE N.T.S. @ A3	
ISSUE FOR	

**INGAL CIVIL PRODUCTS**  
a valmont COMPANY

DRAWING AND CONTENTS ARE COPYRIGHT TO INGAL CIVIL PRODUCTS AND CAN ONLY BE USED WITH PRIOR WRITTEN CONSENT FROM INGAL CIVIL PRODUCTS

157-65 AIRDS ROAD PH: +61 2 9827 3333  
 MINTO, N.S.W 2566 www.ingalcivil.com.au

PROJECT	TITLE
	EZY-GUARD HIGH CONTAINMENT POST ON BASE PLATE ASSEMBLY DETAIL EXPLODED VIEW

INGAL CIVIL PRODUCTS PART No.	DRAWING No.
	EZY-HC-005

Rev. 0

J:\SALES & MARKETING\DRAWINGS\EZY GUARD\HC\EZY-HC005-EXPLODED ASSEMBLY BPLATE.DWG

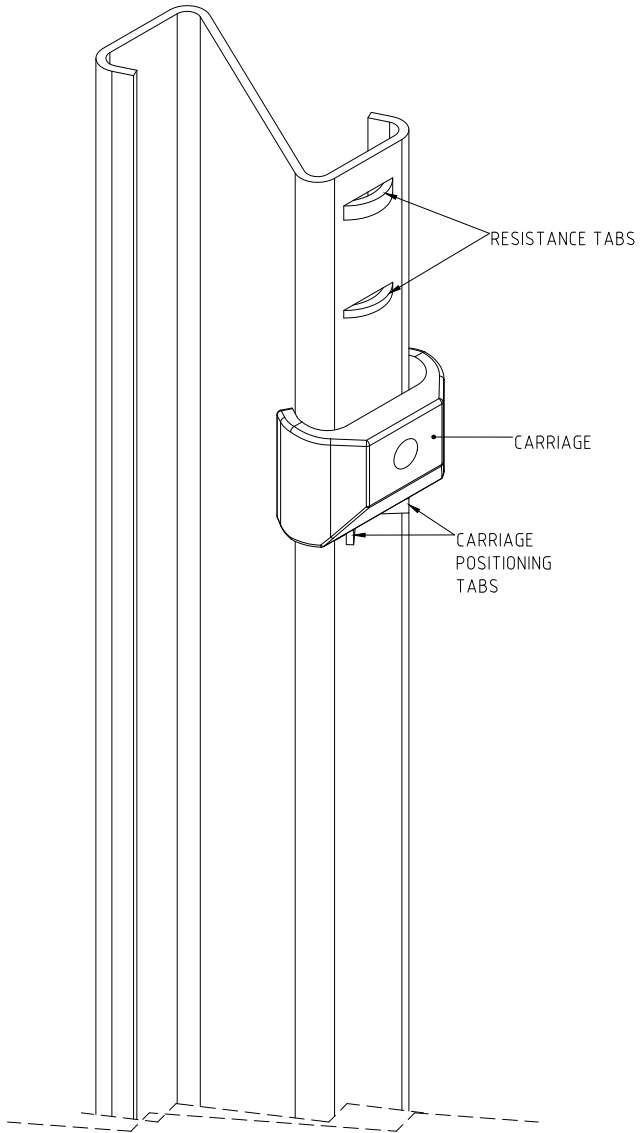

HC "Z" POST & CARRIAGE ASSEMBLY  
ISOMETRIC VIEW

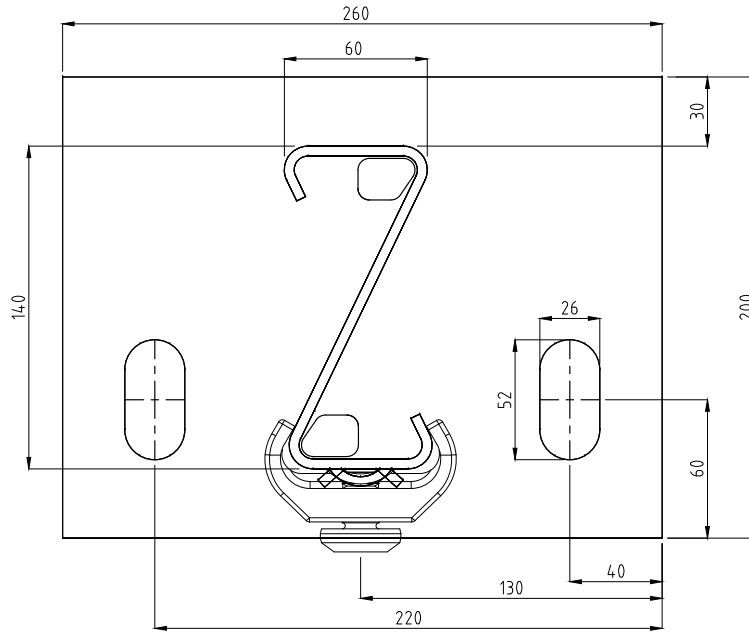

HC "Z" POST & CARRIAGE ASSEMBLY  
PLAN VIEW

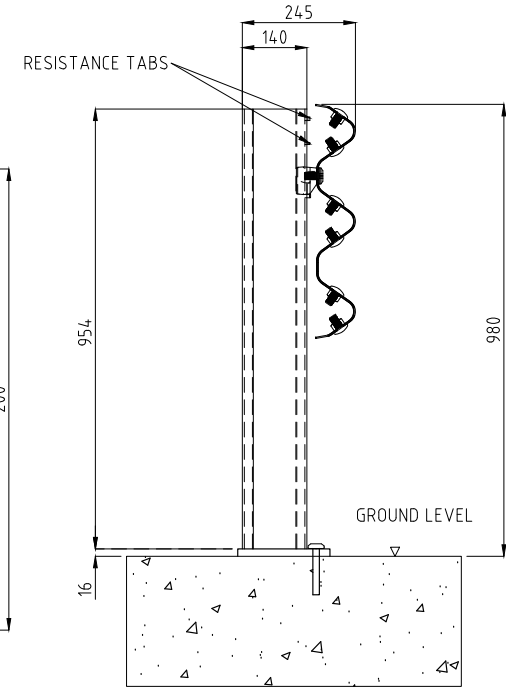

HC "Z" POST & CARRIAGE ASSEMBLY  
SIDE VIEW

REV	DATE	DESCRIPTION	DRAWN	CHECKED	APPROVED	DRAWING NUMBER	REFERENCE DRAWINGS	NAME	DATE	PROJECT	INGAL CIVIL PRODUCTS PART No.	
0		ORIGINAL ISSUE	VB	LG	LG			VB	18/01/2021	<b>INGAL CIVIL PRODUCTS</b> <small>A valmont COMPANY</small> DRAWING AND CONTENTS ARE COPYRIGHT TO INGAL CIVIL PRODUCTS AND CAN ONLY BE USED WITH PRIOR WRITTEN CONSENT FROM INGAL CIVIL PRODUCTS 57-65 AIRDS ROAD PH. +61 2 9827 3333 MINTO, N.S.W 2566 www.ingalcivil.com.au		
								LG	18/01/2021		TITLE	DRAWING No.
								LG	18/01/2021		EZY-GUARD HIGH CONTAINMENT NZTA POST ON BASE PLATE CONFIGURATION DETAIL	EZY-HC-006-NZ

E:\ENGINEERING\SALES & MARKETING\DRAWINGS\EZY-GUARD\NZTA\HC-006-POST ON BASE PLATE CONFIGURATION.DWG

Notes:



A series of horizontal dotted lines spanning the width of the page, intended for writing notes.



*For more information*

contact us on the web

[www.ingalcivil.co.nz](http://www.ingalcivil.co.nz)

**North Island**  
Ph: 021 2464 997

**South Island**  
Ph: 021 1983 311

Email: [sales@ingalcivil.co.nz](mailto:sales@ingalcivil.co.nz)

**Head Office: Sydney**  
57-65 Airds Road, Minto, NSW 2566  
Ph: +61 2 9827 3333  
Fax: +61 2 9827 3300  
Local call (within Australia):  
1300 446 425  
Email: [sales@ingalcivil.com.au](mailto:sales@ingalcivil.com.au)