

DETAIL C

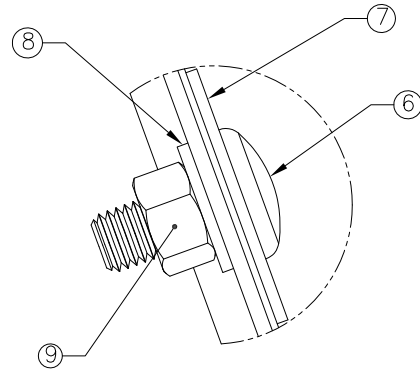

DETAIL D

INGAL MPR ON EZY-HC - 4M BOM			
ITEM	QTY	PART No	DESCRIPTION
1	1	10006773	MPR Rail - 4m NLL
2	2	10008582	HC "Z"-Post bracket
3	2	10006772	Rail mounting bracket
4	4	10001282	M16x180 hex bolt & nut
5	4	10001248	Round head bolt M16x30
6	2	10006769	Round head bolt M16x40
7	2	10006771	Slot washer $\phi 70 \times 2$
8	10	10006770	Washer - $\phi 35 \times 17 \times 4$
9	6	10001254	M16 nut
10	*	10006767	MPR Terminal Piece
11	4	10001242	M16 Round Washer

* ONE TERMINAL PIECE REQUIRED AT BEGINNING AND END OF RUN ONLY.

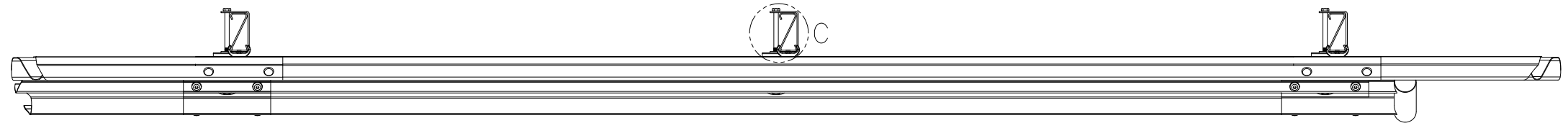

SECTION B-B

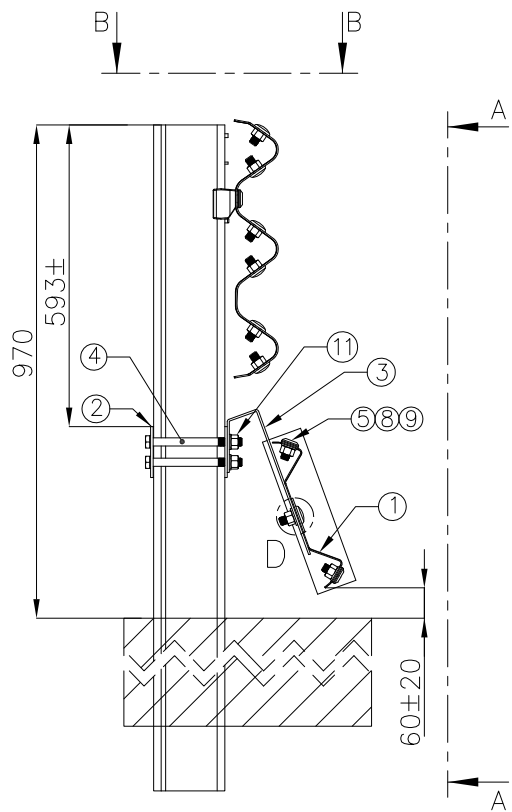

SECTION A-A

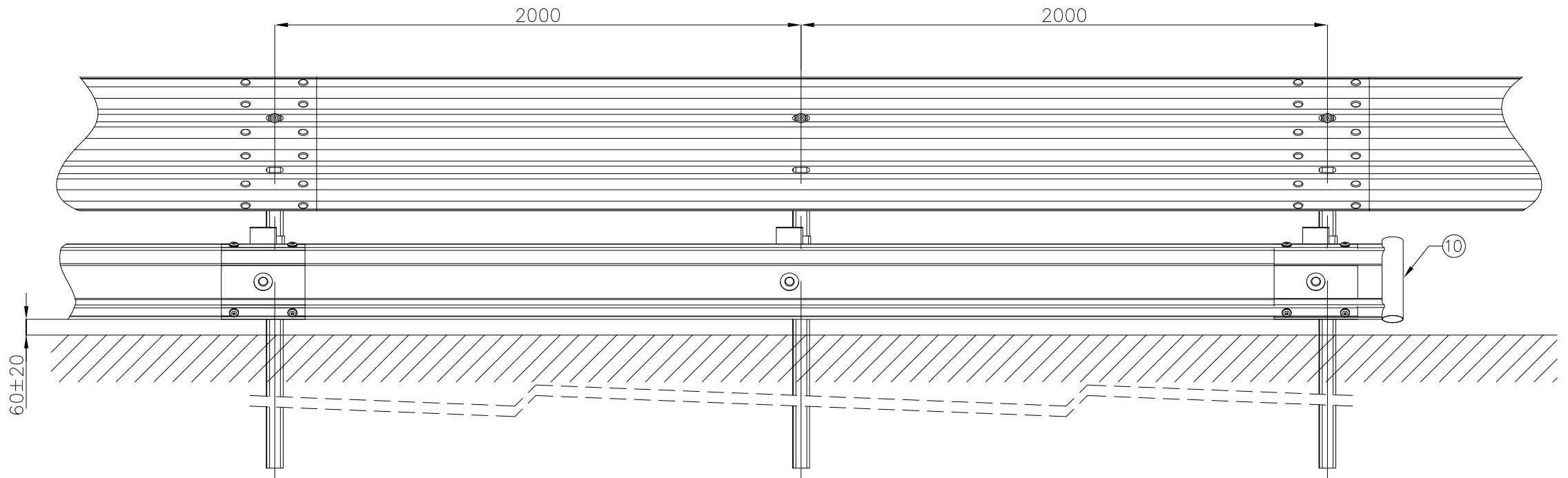

NOTES:
1. ALL STEELWORK TO BE HOT DIP GALVANISED AFTER FABRICATION TO AS/NZS4680.

J:\SALES & MARKETING\DRAWINGS\INGAL MPR\ICP-MPR-014 - EZY-GUARD HC GENERAL ARRANGEMENT.DWG

REV	DATE	DESCRIPTION	DRAWN	CHECKED	APPROVED
0					

DRAWING NUMBER	REFERENCE DRAWINGS

NAME	DATE
DRAWN: WD	09-03-2018
CHECKED: HF	09-03-2018
APPROVED: LG	09-03-2018
SCALE: N.T.S. @ A3	
ISSUE FOR: INFORMATION ONLY	

INGAL CIVIL PRODUCTS
A valmont COMPANY

DRAWING AND CONTENTS ARE COPYRIGHT TO INGAL CIVIL PRODUCTS AND CAN ONLY BE USED WITH PRIOR WRITTEN CONSENT FROM INGAL CIVIL PRODUCTS

57-65 AIRDS ROAD MINTO, N.S.W 2566 PH. +61 2 9827 3333 www.ingalcivil.com.au

PROJECT	TITLE
	INGAL MPR - MOTORCYCLIST PROTECTION EZY-GUARD HC CONFIG GENERAL ARRANGEMENT

INGAL CIVIL PRODUCTS PART No.	DRAWING No.
	ICP-MPR-014

Rev: 0