

*Product Manual*



Release 12/19

## 1.0 Introduction

Introducing Ezy-Guard 4, a member of the Ezy-Guard family, the next generation steel guardrail barrier providing superior motorist safety and more metres of barrier for your dollar.

Ezy-Guard 4 is crash tested to the latest performance standard distinguishing it from the existing New Zealand public domain guardrail barrier system.

The Z-post profile shields post edges from vulnerable road users and provides sectional strength when driving through difficult conditions.

An Ezy-Carriage is used to secure the w-beam rails to the posts eliminating the requirement for blocking pieces and rail stiffening plates. This unique connection provides a soft ride-down for the occupants and smooth vehicle containment and redirection.

## 2.0 Specifications

Ezy-Guard 4 Z-Post Length:	1,650mm
Ezy-Guard 4 Z-Post Mass:	12.5kg
Ezy-Guard 4 System Mass:	18.6kg per metre
Rail Height Above Ground:	787mm
Z-Post Height Above Ground:	777mm
Post Spacing:	1,905mm
Ezy-Guard 4 System Width:	200mm
MASH TL3 Crash Test Deflection:	1.65m

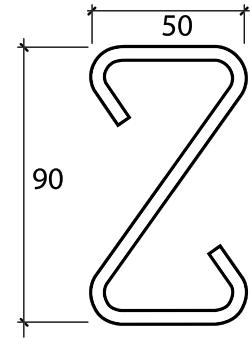

Ezy-Guard 4 rails and Z-posts are manufactured from hot-rolled steel flat products in accordance with AS/NZS 1594. These items are hot dip galvanized in accordance with AS/NZS 4680 after fabrication leaving no surface untreated.



### 3.0 Crash Test Analysis

Crash test guidelines provide a minimum set of requirements that a roadside barrier has to meet in order to demonstrate its satisfactory impact performance.

Whilst crash test guidelines cannot include all possible impact conditions that may be experienced in the real world, the crash test matrix is selected to represent a "worst practical condition" for a roadside barrier impact.

Ezy-Guard 4 has been fully crash tested and evaluated according to the specifications for Test Level 3 (TL3) of the AASHTO Manual for Assessing Safety Hardware (MASH).

The system has also been crashtested in accordance with NCHRP-350 Test Level 4, this is the containment of a 8000kg truck impacting the rail at 80km/h and 15°.

The MASH specification is an update to and supersedes NCHRP Report 350 for the purposes of evaluating new safety hardware devices.

The MASH TL3 crash test matrix requires the following impacts;

- 1100kg car travelling at 100km/h and 25 degrees.
- 2270kg pick-up travelling at 100km/h and 25 degrees.

Crash test impact conditions are defined by the mass, speed, and angle of the impacting vehicle. Crash test standards and performance levels can be compared by calculating the impact severity (IS).

$$IS = \frac{1}{2} M (V \sin \theta)^2$$

Where IS is the impact severity in joules (J), M is the test inertial mass of the vehicle in kilograms (kg), V is the impact speed in metres/second (m/s) and  $\theta$  is the impact angle in degrees.

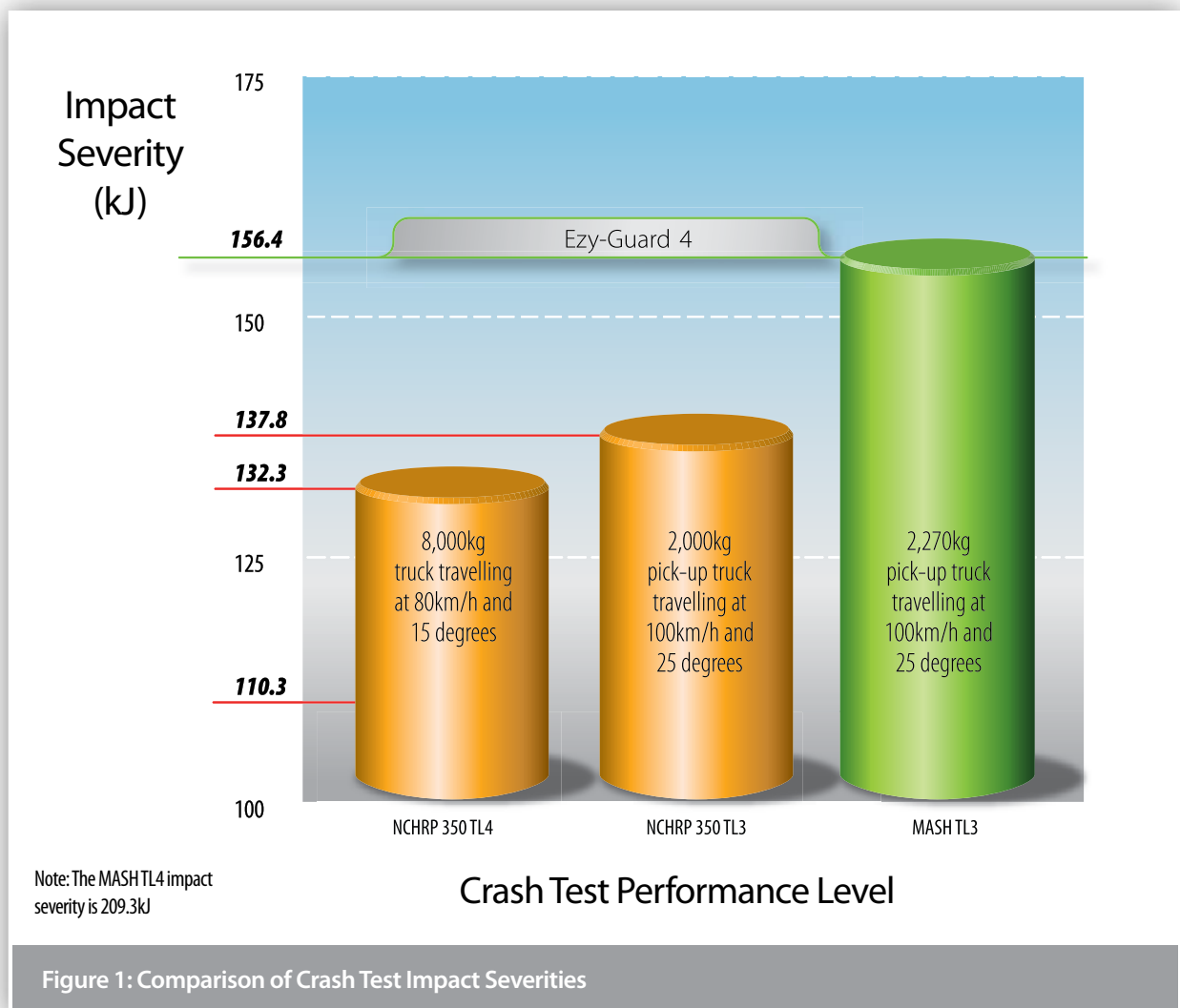



## 4.0 Consideration for Vulnerable Road Users

Vulnerable road users include motorcyclists, pedestrians, cyclists and other road users. Ezy-Guard 4 has been designed to provide consideration to vulnerable road users as follows:

### Rounded Post Corners.

The Z-post contains smooth, rounded post edges and corners mitigating the risk and severity of fractures and/or contusions.

### Energy Absorbing, Ductile Z-Posts.

The Z-posts are designed to yield by bending near ground level. This bending action absorbs impact energy reducing the potential for post fracturing. A fractured or split guardrail post presents a significant laceration hazard to vulnerable road users.

The Ezy-Guard 4 design does not contain any elements that become projectiles and there are no aggressive edges.

### Shielded Posts.

The revolutionary design of Ezy-Guard 4 shields the top of the supporting Z-posts by positioning the top of the

rail above the posts. This eliminates dangerous snag points, reducing the potential for the barrier to dismount motorcyclists or cyclists. This is a significant safety benefit compared to all guardrail and cable barrier designs currently used within New Zealand.

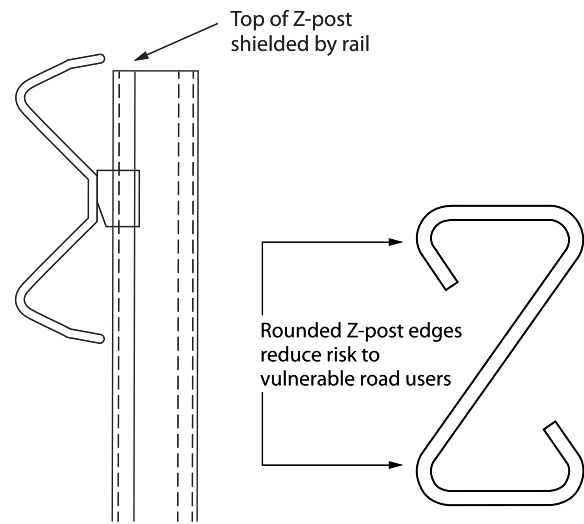

Figure 2: Ezy-Guard 4 Considerations for Vulnerable Road Users



## 5.0 Features and Benefits

### 5.1 Fully Compliant to MASH TL3 & NCHRP-350 TL4

Ezy-Guard 4, a member of the Ezy-Guard family, is fully compliant to MASH TL3 and NCHRP-350 TL4.

The MASH TL3 test condition represents a 13% increase in energy when compared to NCHRP 350 Test Level 3 impacts.

The NCHRP-350 TL4 compliance demonstrates the systems ability to contain and redirect the large 8000kg truck, which has a higher centre of gravity compared to the MASH TL3 truck.

**MASH TL3 COMPLIANT**

**NCHRP-350 TL4 COMPLIANT**

### 5.2 Rapid Installation & Repair

Ezy-Guard 4 installation can be up to twice as fast to install than conventional guardrail barriers and unlike cable barrier systems, no concrete is required.

The Ezy-Guard 4 design uses fewer components and features 1,650mm Z-posts that are rapidly driven into the ground. The Z-post embedment depth is just 873mm, a significant reduction when compared to other guardrail posts. This reduces installation time providing significant cost savings.

Since the Z-posts are designed to yield by bending near ground level, damaged posts can be removed easily which reduces the time spent by work crews on the roadside.

### 5.3 Narrow Width

With a system width of just 200mm, Ezy-Guard 4 is significantly narrower than traditional guardrail barriers that incorporate the use of blocking pieces. Ezy-Guard 4 conserves valuable formation width and allows a greater recovery width to be provided for errant vehicles.

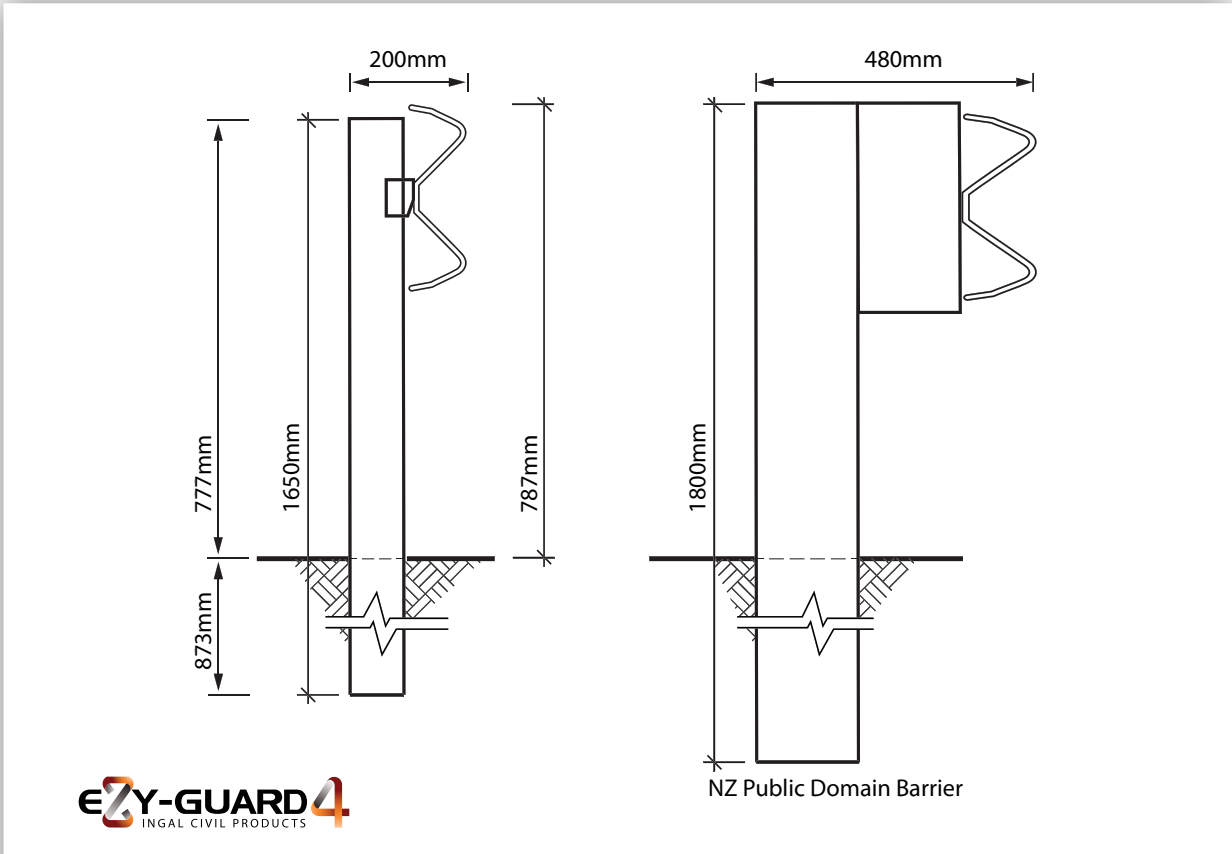

Figure 3: Ezy-Guard 4 Width Comparison

#### 5.4 Installation in Rock, Asphalt or Concrete Mowing Strips

The design of the Z-post differs from traditional posts in that it relies on the yielding of the post by bending near ground level rather than the yielding of the surrounding soil during a vehicle impact. This makes the Z-post suitable for installation in rock, asphalt or concrete mowing strips.

A traditional guardrail post is designed to absorb some crash energy through post rotation in the soil prior to post failure. Restraining these traditional posts by setting them in narrow holes drilled into solid rock, by setting them in thick asphalt layers or concrete, or by placing a mowing strip around the posts can lead to a failure of the system to safely contain and redirect the errant vehicle.

#### 5.5 Manual Handling

Ezy-Guard Smart uses fewer components than the public domain guardrail systems. Z-posts weighing just 12.3kg are 50% lighter than traditional C-posts. The lightweight Z-post reduces manual lifting by installation crews.

The rounded edges of the Z-post provides a handlelike grip when lifting, reducing the possibility of hand lacerations. The Z-profile allows the installer to maintain a firm grip and facilitates correct lifting techniques.

#### 5.6 Locally Designed & Produced

Ezy-Guard Smart is manufactured in Australia by Ingal Civil Products using steel manufactured by BlueScope Steel. Z-posts and rail are stamped providing traceability to material mechanical and chemical analysis certificates. Hot dip galvanising is performed internally by Ingal and daily inspections ensure zinc thickness readings are in accordance with AS/NZS standards.

#### 5.7 Soft Ride-Down Decelerations

The Ezy-Carriage controls the release of the w beam rail from the Z-posts. This controlled release reduces the potential for vehicle pocketing and provides a soft ridedown for vehicle occupants.



## 6.0 Performance

Ezy-Guard 4 provides protection from roadside hazards located close to the edge of the travelled way. The sectional strength of the 4 Z-post reduces lateral deflection whilst providing controlled containment and redirection.

Crash testing guidelines provide a set of requirements that is “worst practical conditions” in order to demonstrate the barriers impact performance. When the combined effects of vehicle mass, impact speed and angle of impact are considered, the testing criteria represents the extremes of impact conditions to be expected in real-world situations.

### 6.1 Deflection

The transverse deflection of a barrier during a crash is dependant upon the following;

- Mass of the impacting vehicle;
- Speed of the impact vehicle; and
- Angle of the vehicle impact.

Since crash testing typically represents the extremes of these parameters, a review of the proposed barrier location can be undertaken to assess the following;

- Maximum attainable impact angle;
- Design speed; and
- Design vehicle.

Figure 4 illustrates the vehicle trajectory when turned towards the barrier. The maximum attainable angle,  $\phi$  is limited by the speed of the vehicle and the lateral offset,  $x$  to the barrier.

The maximum attainable angle for various speeds and offsets is shown in Figure 6 and is derived using a point mass model and assumes maximum steering and a coefficient of friction of 0.7 (dry pavement). Once the angle of impact is determined, dynamic deflections for various design vehicles can be selected from Tables 1 or 2.

#### Example:

A barrier is to be installed on a roadway with a posted speed of 90km/h. The lateral offset to the barrier is 5m.

- Step 1: Using Figure 6, the maximum attainable impact is calculated as 20 degrees.
- Step 2: The design vehicle is selected as 2,000kg or 2,270kg.
- Step 3: The deflection value from the corresponding table is selected. This is as follows;
  - 2,000kg design vehicle – 0.8m
  - 2,270kg design vehicle – 0.9m

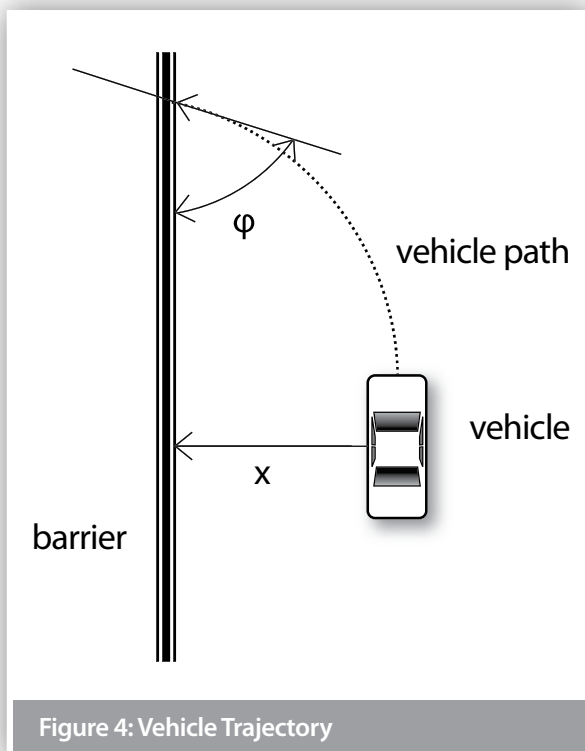

Figure 4: Vehicle Trajectory

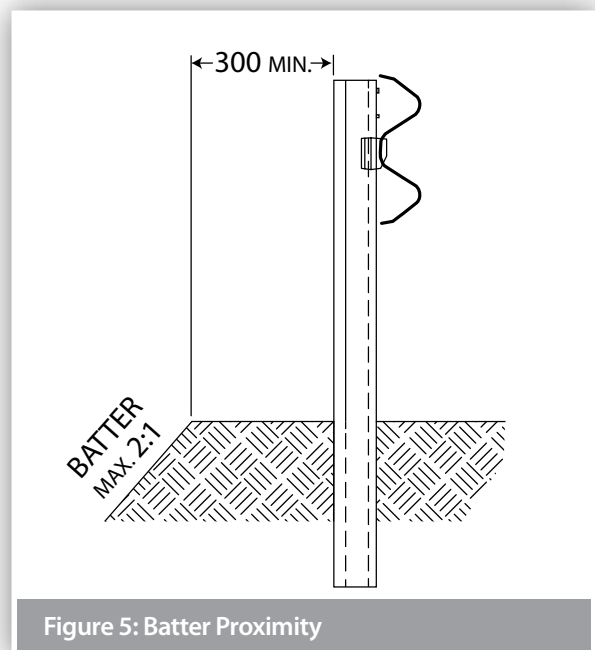
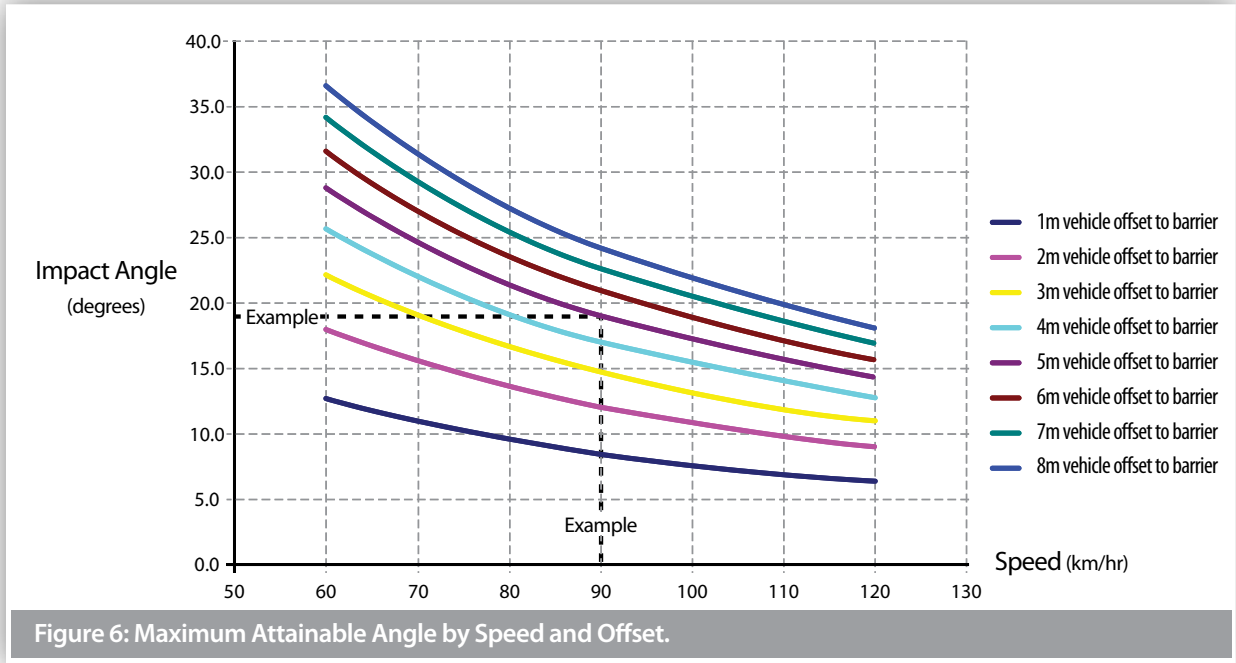

Figure 5: Batter Proximity





**Table 1. Ezy-Guard 4 Deflections**

Speed (km/h)	Dynamic Deflection (m)		
	Post Spacing	Test Standard	Dynamic Deflection
70	1.905m	NCHRP-350 TL2	0.89
80	1.905m	NCHRP-350 TL4	1.53
100	0.953m	NCHRP-350 TL3	1.04
100	1.905m	MASHTL3	1.65

\* If further reduction of the deflection is required, please contact your local Ingal Civil Products representative.





## 7.0 Installation

### 7.1 Terminals

Guardrail end terminals are designed to provide a soft gating impact preventing the end rail from spearing an impacting vehicle. Terminals also introduce tensile and flexural strength necessary to ensure redirection performance of the length-of-need section.

Ezy-Guard 4 is installed at a system height of 787mm, measured to the top of the rail. This height is compatible with our range of proprietary and public domain terminals, refer to installation drawings.

Departure terminals should only be installed if they are located outside the clear zone of approaching traffic. See Figure 7. The clear zone is the horizontal width of space available for the safe use of an errant vehicle.

The clear zone is dependant upon the speed of the vehicle. Guidelines are contained with regulatory publications.

Terminals should be installed in accordance with the proprietor's drawings and specifications. Z-posts are not to be used in the terminals unless approved by the proprietor.

The installation of terminals will typically incorporate the use of blocking pieces positioned between the posts and rail. This will require the supporting posts to be offset from the set-out line used for the installation of the Z-posts which do not require blocking pieces.

In addition, the post spacing used in the terminals and transitions may vary from the 1.905m spacing used for installation of Ezy-Guard 4. The required post spacing for terminals and transitions will be contained in the proprietor's drawings.

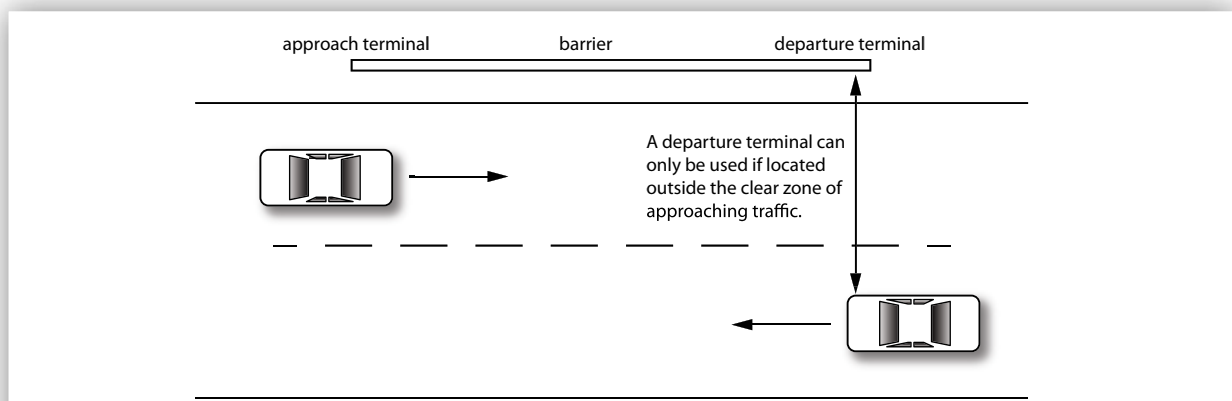

Figure 7: Clear Zone Requirement for the use of Departure Terminals



Figure 8: SoftStop MASH End Terminal

## 7.2 Minimum Length Requirements

There are two geometric methods used to determine the likely trajectory of a vehicle that leaves the road in the vicinity of a roadside hazard and the minimum length of barrier required to protect from this hazard. The most common method is the run-out length method and an alternative is a method based on angle of departure.

Prior to design or installation, designers should consult the relevant road controlling authority to establish the local jurisdictional practice as the methods may result in different lengths. Both methods are detailed in the Austroads Guide to Road Design – Part 6.3.

For instances where geometric constraints limit the installation of the recommended length under the above design methods, the absolute minimum length of minimum length of need for Ezy-Guard 4 is dependent on the design containment level.

- Test Level 2 containment, where the design vehicle is a 2,000kg pick-up, the minimum length of Ezy-Guard 4 between terminals is 12m.
- MASH Test Level 3 containment, where the design vehicle is a 2,270kg pick-up, the minimum length of Ezy-Guard 4 is 20m between terminals.
- NCHRP-350 Test Level 4 containment, where the design vehicle is a 8,000kg truck, the minimum length of Ezy-Guard 4 is 56m in between terminals.

## 7.3 Sequence of Work

Where Ezy-Guard 4 is being constructed on a road open to traffic, it is recommended that the work commence at the end closest to the approaching traffic. Leading terminals and transitions shall be commissioned at the earliest practical time.

## 7.4 Modifications

Ezy-Guard 4 shall be constructed in the configuration as detailed in Ingal Civil Products' drawings. This is the configuration in which the system has been crash tested. No modifications shall be made to the system unless verified by Ingal Civil Products.

Flame cutting of rails or posts is not permitted. Saw cutting and drilling is permitted in the event that a post is to be installed at an irregular spacing and/or rock is encountered and the post embedment depth has been modified in accordance with Table 3.

Any modification carried out after fabrication will require repair to the galvanized coating. This is undertaken by applying two coats of an organic zinc rich epoxy paint complying with AS/NZS 3750.9. This is to be applied to the repair areas in two coats. Each coat shall have a minimum dry film thickness of 50 µm.

## 7.5 Soil Requirements & Embedment Depth

The Z-post is designed to yield by bending near ground level during impact. Provided the post is embedded in material that allows this failure mechanism to be replicated, the Ezy-Guard 4 functionality will be retained. The Z-posts will provide lateral resistance until the impacting vehicle causes deformation of the posts. At this point the Ezy-Carriages will provide a controlled release of the rail from the Z-posts resulting in safe vehicle containment and redirection.

### 7.5.1 Standard Soil

Ezy-Guard 4 has been evaluated for installation in standard soil in accordance with AASHTO standard specifications for 'Materials for Aggregate and Soil Aggregate Subbase, Base and Surface Courses,' designation M 147.

When installed in standard soil, the 880mm embedment depth of the Z-post is sufficient for installation up to the rounding point on 2:1 embankment slopes.

### 7.5.2 Weak Soil

Ezy-Guard 4 has been evaluated for installation in weak soil in accordance with AASHTO standard specification for 'Fine Aggregate for Hydraulic Cement Concrete,' designation M 6.

When installed in weak soil, the 880mm embedment depth of the Z-post is sufficient for installation up to 500mm of the rounding point on 2:1 embankment slopes. If installation is required within 500mm of the rounding point, the post embedment depth is required to be increased to 1,050mm. A longer Z-post is available from Ingal for these applications.



### 7.6 Post Pullover Test

In the event that the soil type cannot be verified, the suitability of the post foundation can be established through a post pullover test.

This is undertaken by applying a 1kN load to the post, 700mm above ground level. The load is applied prior to the attachment of the rail. Displacement at the base of the post shall not exceed 1mm whilst the load is applied.

An alternative post pull over test can be achieved via a more destructive means, whereby a load of 1.2 tonnes is applied to the test post at a height of 700mm. This loading approximates the probable capacity of the post and should be able to be maintained with minimal rotation of the post in the soil. At the completion of the testing the post should be removed from the test location and should not be used in the installation.

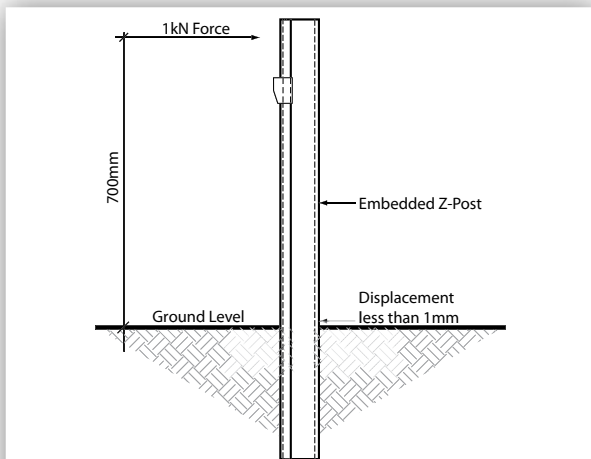

Figure 9: Z-Post Pullover Test



Figure 10: Z-Post on Base Plate

### 7.7 Posts on Base Plates

In the event that the Z-post cannot be installed to the required in-ground depth due to a culvert or conflict with underground services, baseplated post mounted on a suitable foundation can be adopted. Refer to Ingal Civil Products drawings for the installation of posts on base plates and appropriate foundation designs

### 7.8 Z-Posts in Rock

Traditional guardrail posts are designed to yield in the surrounding soil and their placement in rock or concrete is problematic. Restraining the traditional posts by setting them in narrow holes drilled into rock, setting them in concrete or placing a mowing strip around the posts can lead to a failure of the system to safely contain and redirect the errant vehicle.

The Z-post dissipates energy by yielding through bending near ground level. Therefore the typical recommendations for the installation of a traditional guardrail posts in rock are not applicable to the Zpost. If rock is encountered, the installation guidelines as detailed in Table 3 can be considered by the site engineer. If required, the post may be cut onsite by a disc grinder or equivalent cutting tool. A corrosion resistant treatment will need to be applied to the freshly cut surface, ICP recommend a Zinc metal spray in accordance with ISO 2063 or AS/NZS 2312..

### 7.9 Non-Standard Post Spacing

Occasionally, a roadside hazard may prevent a post from being installed at the recommended spacing. In these instances it may be possible to stiffen the barrier with reduced post spacing on the approach and trailing side of the hazard, we would recommend you discuss these options with your local Ingal Civil Products representative.

### 7.10 Delineation

To be in accordance with NZTA M14: 2011.





**Table 3: Installation of Ezy-Guard 4 Z-Posts in Rock\***

Site Condition	Installation Requirements	
<p>Rock is encountered at the surface.</p>	<p>Drill a 110-300mm diameter hole to a depth of 450mm, install the post in the hole and backfill.</p>	
<p>Rock is encountered within 450mm of the surface.</p>	<p>Drill a 110-300mm diameter hole 450mm into the rock or to a minimum total post embedment depth of 650mm, whichever comes first, install the post and backfill.</p>	

\* to be read in conjunction with section 7.8.

Site Condition	Installation Requirements	
<p>Rock is encountered 450mm to 600mm below ground.</p>	<p>Drill a 110-300mm diameter hole 200mm into the rock or to a minimum total post embedment depth of 650mm, whichever comes first, install the post and backfill.</p>	
<p>Rock is encountered 600mm to 800mm below ground.</p>	<p>Drill a 110-300mm diameter hole 50mm into the rock or to a minimum total post embedment depth of 800mm, whichever comes first, and install the post and backfill.</p>	

\* to be read in conjunction with section 7.8.

### 7.11 Curving of Rails

Guardrail used for the assembly of Ezy-Guard 4 may be shop curved to fit any radius from 2.4m to 45m Convex. Curves under 25m Radius please refer to NZTA technical note TM 2008.

Ezy-Guard 4 for Concave Curves can be used from 2.4m to 45m. Curves in excess of 45m do not require shop curving as the rail can be field installed to suit. Guardrail may be curved either concave or convex to the traffic face and can be part-curved along its length to suit site requirements.

#### 7.11.1 Measuring Curvature

1. Mark along the arc of the curve at 3.81m intervals.
2. Measure the corresponding chord length (C) - refer to Figure 11.
3. Measure the corresponding centre offset (H) - refer to Figure 11.
4. Use the values for C & H to select the radius from Table 4.
5. Determine the curvature orientation from Figure 12.

#### 7.11.2 Identification of Curved Rails

Where a rail has been factory curved by Ingal, the radius of curvature is marked on the rear face of the rail.

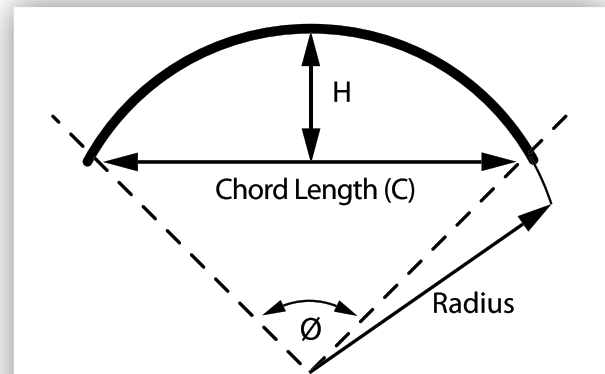

Figure 11: Curvature Measurements

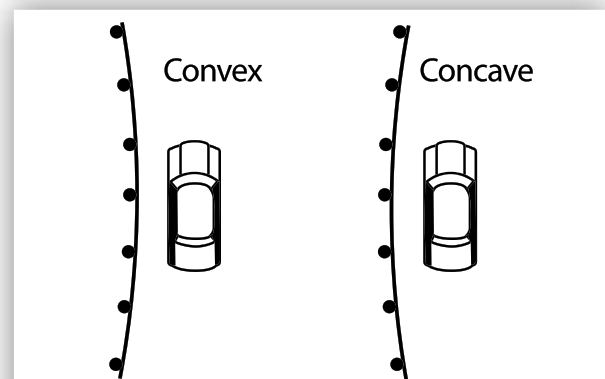

Figure 12: Curvature Orientation

Table 4: Rail Curvature Values (3.81m Arc Length)

Radius (m)	∅ Degrees	C (mm)	H (mm)
2.4	90	3422	717
3	73	3560	585
4	55	3668	445
5	43	3718	359
6	36	3746	300
7	31	3763	258
8	27	3774	226
9	24	3782	201
10	22	3787	181
12	18	3794	151
14	16	3798	129
16	14	3801	113
20	11	3804	91
24	9	3806	76
28	8	3807	65
32	7	3808	57
35	6	3808	52
40	5	3809	45
45	5	3809	40





### 7.12 Installation Sequence

The following written instructions should be read in conjunction with Ingal Civil Products' drawings.

A generic Safe Work Method Statement is available from Ingal Civil Products to assist in the safe installation of Ezy-Guard 4.

Only items purchased from Ingal Civil Products shall be used for the construction of Ezy-Guard 4.

1. Ensure the area has been inspected for underground hazards and that suitable traffic control is in place.
2. Post locations are marked ensuring any fixed object hazard to be protected is located outside the expected dynamic deflection of the barrier.
3. The post lugs are to be at the top of the post and facing the traffic as per Figure 13 and 14.

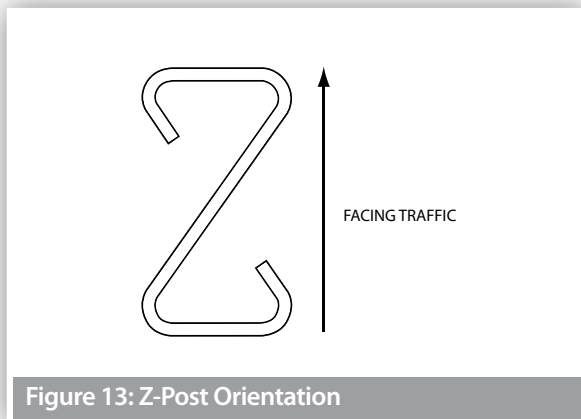

4. Posts are driven directly into the ground and should be vertical. The post installation process shall not cause damage to the post, such that it reduces the effective operation of the safety barrier or its design life, or introduces sharp tearing edges, nor shall it cause damage to pavement. If the Ezy-Carriage cannot freely move as it is attached to the post as a result of deformation of the post during installation, then the post shall be replaced.

The use of a vibrating post hammer will reduce deformation to the top of the post and install the post at a controlled rate.

5. Alternate to driving the posts, a minimum 110-300mm hole can be augured and the post placed in the hole. The posthole is then backfilled with the material that was excavated. If installing in soil, the material should be placed in layers of 150mm and suitably compacted to not less than the density of the surrounding layers.
6. Posts are spaced at 2m – Lesser spacings are required on transitions to Thriebeam, and where requested by an engineer.

7. The height of the Z-post above ground level is 777mm.
8. The Ezy-Carriage is attached to the face of the post. The Ezy-Carriage will come to rest on the positioning lug fabricated on the Z-post.

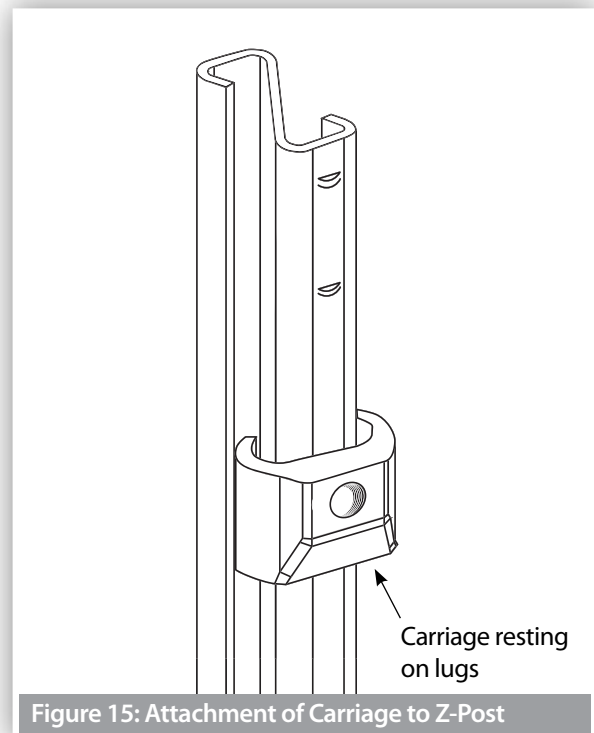
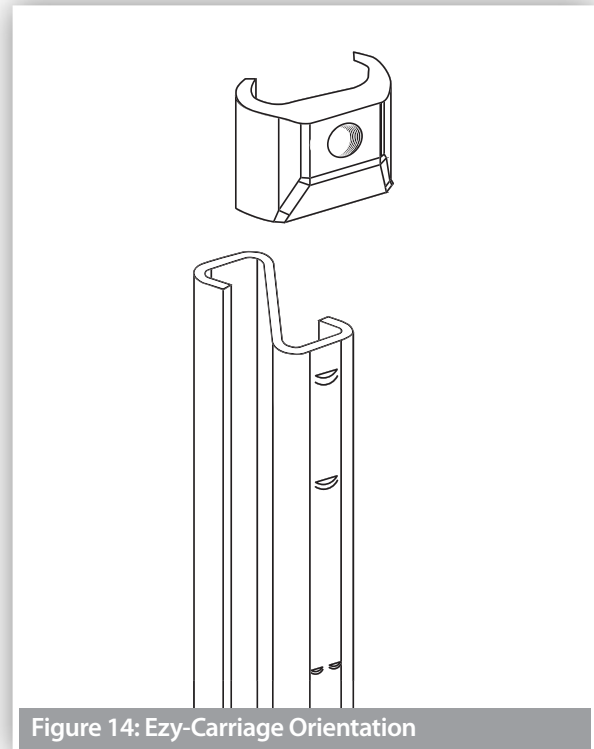

- Rails are attached to the Ezy-Carriage using the M16x30mm post bolts. The post bolts are identified by the socket recess located in the head of the bolt. The bolts are tightened to snug tight using a 10mm hex. key.

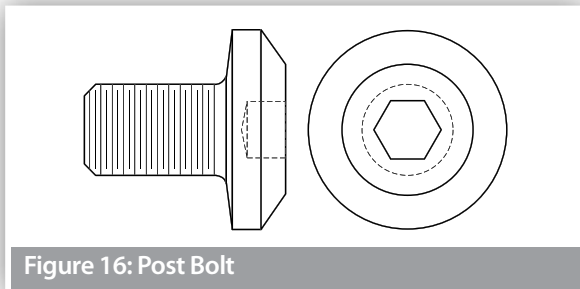

- Rails are spliced together at every second post using M16x32mm mushroom head bolts and oversized nuts. There are 8 bolts required per splice connection. A pinch bar may be used to assist in the alignment of splice holes. The use of a driving pin to elongate the slots is NOT to be used since this may cause tearing of the rail at the slot location. The bolts are tightened to snug tight.

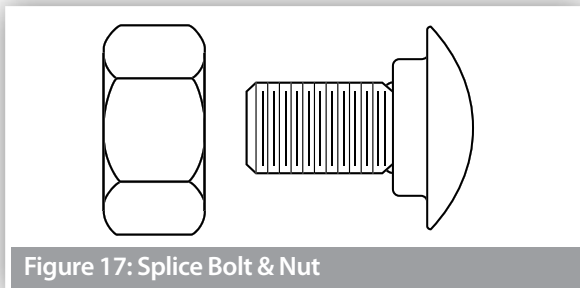

- Rails are orientated so that no leading edge is presented to the traffic face as shown in Figure 18.

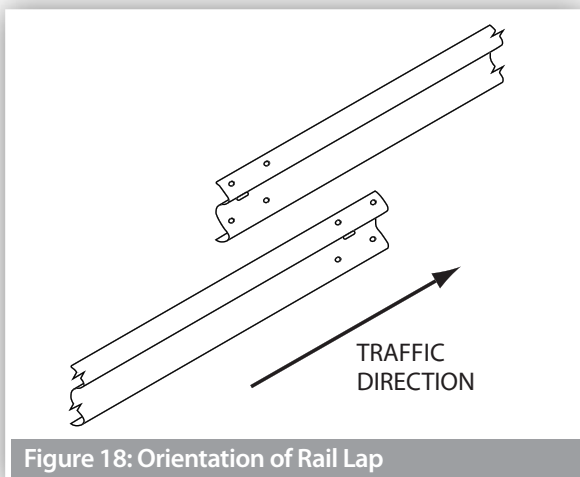

- It is recommended that posts be installed only a few metres ahead of rail assembly to ensure correct post spacing and alignment. On curves, the rails can be used as a template and laid on the ground to determine post locations.
- The construction of Ezy-Guard 4 shall form a smooth line vertically and horizontally when viewed along the line of the system, free from humps, sags or other irregularities.
- The Ezy-Guard 4 components are to be free from splits, burrs or sharp edges after installation. Any minor damage to the galvanise coating is to be repaired by applying two coats of an organic zinc rich paint.
- Any disturbed pavement or material around a post shall be left dense, tight, and smooth so that resistance to water penetration is similar to that of the adjacent surface.

### 7.13 Back to Back W-Beam Installation

The Ezy-Guard 4 system can also be used in median applications where the W-Beam is installed on both sides of the post. This configuration requires a special post with resistance tabs on both sides of the post. The installation procedure is the same as for a single sided installation with steps 8 thru 15 repeated on the opposite side of the post. Refer drawing Ezy-SM-035 for further assembly detail.

### 7.14 Installation Tolerances

- The tolerance on height of the barrier shall be plus 30mm / minus 0mm.
- The tolerance for the line of the barrier shall be plus or minus 20mm in plan view.
- The tolerance for departure from the upright axis shall be plus or minus 15mm at the top of the barrier.
- The tolerance on post spacing shall be plus or minus 25mm.

## 8.0 Maintenance

### 8.1 Preventative Maintenance

It is recommended that annual inspections be performed to ensure the following;

- The system is appropriately delineated;
- Debris has not accumulated around the system that may impede the performance of the barrier or the trajectory of an impacting vehicle;
- The system is suitably anchored with appropriate terminals and/or transitions. If the system is anchored with terminals, the cable assembly shall be taut and tensioned to its recommended value; and
- All splice bolts and post bolts are snug tight.

## 8.2 Ezy-Lift for Maintenance Overlays

For existing Ezy-Guard installations where the road surface has been overlaid or resurfaced, resulting in the barrier height being outside of the installation tolerance, the Ezy-Lift carriage is available to bring the W-Beam back to the appropriate height. The carriage gives the option to lift the W-Beam by +50, +100, +150 and +180mm. Refer assembly drawing EZY-SM-137 for further detail.

Installation sequence:

1. Unbolt M16x32 Splice Bolts at splice joint at either end of W-Beam rail.
2. Unbolt each carriage bolt on W-Beam rail. Exercise caution on removal of carriage bolts as rail will be unsupported after removal and may fall to the ground.
3. Lay W-Beam on ground adjacent to original position.
4. Remove carriage from post and replace with Ezy-Lift Carriage.
5. Reinstall carriage bolt and M16 washer into lowest hole in carriage and tighten to snug tight using a 10mm hex key. Refer Detail A.
6. Repeat steps 1 through 5 until required W-Beam rail has been disassembled.
7. Determine the required lift by measuring the height of overlay. The nominal W-Beam height of Ezy-Guard 4 is 787mm.
8. Rails are to be re-attached to the Ezy-Lift carriage using a M16x30mm post bolts and 75x45mm rectangular washer at each post.
9. Rails are overlapped so that no leading edge is presented to the traffic face as shown in Figure 18.
10. Rails are spliced together at every second post using M16x32mm splice bolts and oversized nuts. There are 8 bolts required per splice connection. A pinch bar may be used to assist in the alignment of splice holes. The use of a driving pin to elongate the slots is NOT to be used since this may cause tearing of the rail at the slot location. The bolts are tightened to snug tight.





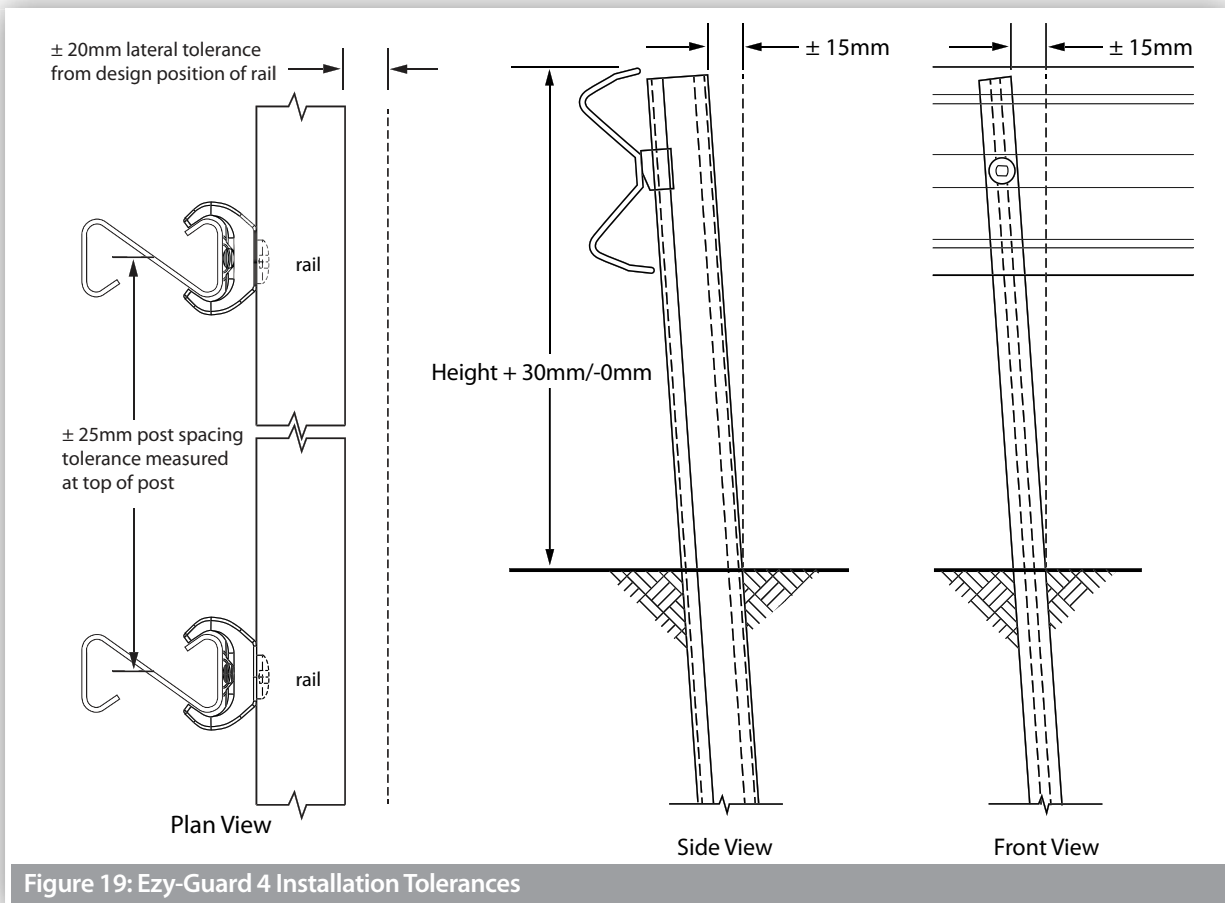

### Ezy-Guard 4 Installation Checklist

Customer:

Project:

Barrier ID:

Barrier Length:

Checked By:

Signed:

Date

Have the Z-posts been positioned every 1.905m	<input type="checkbox"/> Yes	<input type="checkbox"/> No
Carriages are positioned on the posts between the retaining lugs and the resistance tabs	<input type="checkbox"/> Yes	<input type="checkbox"/> No
Rails are installed to the correct height (787mm) and within the tolerances of section 7.14	<input type="checkbox"/> Yes	<input type="checkbox"/> No
Have the Ezy-Carriages been correctly orientated (as per EZY-SM-034)	<input type="checkbox"/> Yes	<input type="checkbox"/> No
Have the rails been attached to the Ezy-Carriages using the post bolts with the socket recess	<input type="checkbox"/> Yes	<input type="checkbox"/> No
Have the rails been spliced observing the correct lap	<input type="checkbox"/> Yes	<input type="checkbox"/> No
Have the rails been spliced with M16x32mm mushroom head bolts	<input type="checkbox"/> Yes	<input type="checkbox"/> No
Are all splice bolts and post bolts snug tight	<input type="checkbox"/> Yes	<input type="checkbox"/> No
Is Ezy-Guard 4 suitably anchored with approved terminals	<input type="checkbox"/> Yes	<input type="checkbox"/> No
Are the cables in the terminals tensioned to their nominated torque where required	<input type="checkbox"/> Yes	<input type="checkbox"/> No
Has any minor damage been repaired using two coats of an organic zinc rich paint	<input type="checkbox"/> Yes	<input type="checkbox"/> No
Does the barrier form a smooth line vertically and horizontally when viewed along the system	<input type="checkbox"/> Yes	<input type="checkbox"/> No
Is the barrier system free from humps, sags or other irregularities	<input type="checkbox"/> Yes	<input type="checkbox"/> No
Has the ground or pavement around the post been left dense, tight and smooth (in-ground only)	<input type="checkbox"/> Yes	<input type="checkbox"/> No

#### Surface Mount Variant:

Are the footing dimensions as per EZY-SM-102	<input type="checkbox"/> Yes	<input type="checkbox"/> No
Is the cast-in assembly arranged as per EZY-SM-125	<input type="checkbox"/> Yes	<input type="checkbox"/> No
Are anchoring options as per EZY-SM-136	<input type="checkbox"/> Yes	<input type="checkbox"/> No

#### Disclaimer:

Important Note: The conformity of the installation is the responsibility of the installation contractor, and Ingal Civil Products accepts no liability for or in connection with any installation that is outside of the specifications of this manual or the NZTA. For more information, please refer to our Standard Terms and Conditions of Sale available on our website: [www.ingalcivil.co.nz](http://www.ingalcivil.co.nz).

## 9.0 Repair

### 9.1 Damage Assessment

In the event of a vehicle impact, damage to the barrier is to be assessed in accordance with Table 5.

A Safe Work Method Statement is available from Ingal Civil Products upon request to assist in the safe repair of Ezy-Guard 4.

Any item that is replaced is to be reinstated observing the installation tolerances nominated in Section 7.14.

Only items purchased from Ingal Civil Products shall be used for the repair of Ezy-Guard 4.

### 9.2 Dismantling Sequence

Prior to undertaking dismantling due to a vehicle impact, the area should be assessed for hazards. These include trip hazards, sharp edges and snag points.

During a vehicle impact, the rail will disengage from the posts as they yield by bending at ground level.

The recommended dismantling sequence is as follows;

1. Dismantle the rail splice by removing the M16x32mm mushroom head bolts and nuts. There are 8 bolts located at each splice location.
2. Rails that are still attached to posts outside the impact area are disconnected by removing the M16x30mm post bolts. A 10mm hex key is required.
3. Once the area is clear of damaged rail, the posts can be removed. Since the posts yield by bending near ground level, a sling or chain can be attached below the bent section.
4. The damaged post can be lifted using a backhoe or post extractor attachment.
5. Any disturbed pavement material shall be left dense, tight, and smooth prior to the installation of replacement posts.

**Table 5: Damage Assessment of Ezy-Guard 4**

Type of Defect	Description of the Defect	Action to be Taken
Galvanizing damage on Z-Posts.	The sum total of the damaged area does not exceed 35cm <sup>2</sup> (0.5% of the total surface area). The sum total of the damaged area exceeds 35cm <sup>2</sup>	An organic zinc rich epoxy paint is to be applied to the repair area in two coats. The Z-post is to be replaced.
Galvanizing damage on rails.	The sum total of the damaged area does not exceed 200cm <sup>2</sup> (0.5% of the total surface area) and no individual damaged area does not exceed 40cm <sup>2</sup> . The sum total of the damaged area exceeds 200cm <sup>2</sup> (0.5% of the total surface area) and/or an individual damaged area exceeds 40cm <sup>2</sup> .	An organic zinc rich epoxy paint is to be applied to the repair area in two coats. The rail is to be replaced.
Mechanical damage on Ezy-Carriages.	The Ezy-Carriage has chips or cracks.	The Ezy-Carriage is to be replaced.
Mechanical damage on Z-Posts.	The post is bent. The Ezy-Carriage cannot travel freely along the post due to distortion.	The post is to be replaced. The post is to be replaced.
Mechanical damage on rail.	The rail is dented, twisted or flattened. There are tears in any part of the rail. The slots in the rail are distorted.	The rail is to be replaced. The rail is to be replaced. The rail is to be replaced.
Mechanical damage on bolts.	The body of the bolt is distorted. The thread of the bolt is damaged.	The bolt is to be replaced. The bolt is to be replaced.
Disturbance of material around posts	The material around the post is loose or uncompacted.	Any disturbed pavement or material around a post shall be left dense, tight and smooth so that resistance to water penetration is similar to that of the adjacent surface.

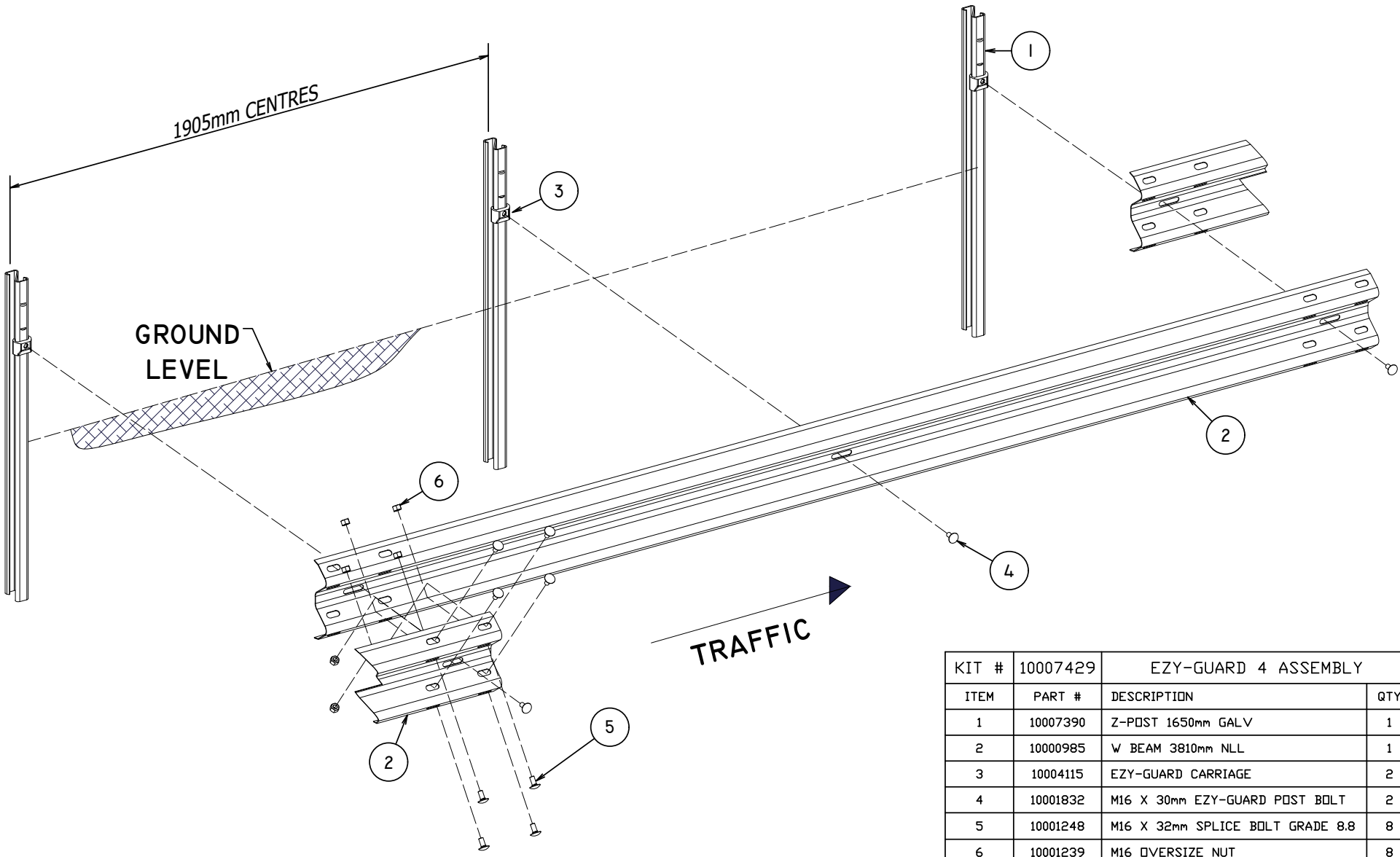

KIT #	10007429	EZY-GUARD 4 ASSEMBLY	
ITEM	PART #	DESCRIPTION	QTY
1	10007390	Z-POST 1650mm GALV	1
2	10000985	W BEAM 3810mm NULL	1
3	10004115	EZY-GUARD CARRIAGE	2
4	10001832	M16 X 30mm EZY-GUARD POST BOLT	2
5	10001248	M16 X 32mm SPLICE BOLT GRADE 8.8	8
6	10001239	M16 OVERSIZE NUT	8

REV	DATE	DESCRIPTION	DRAWN	CHECKED	APPROVED
1	25/11/19	PART_LISTS_UPDATED	VB	LG	LG

DRAWING NUMBER	REFERENCE DRAWINGS

NAME	DATE
DRAWN MC	18/08/15
CHECKED LG	25/08/15
APPROVED LG	25/08/15
SCALE	N.T.S. @ A3
ISSUE FOR	INFORMATION ONLY

**INGAL CIVIL PRODUCTS**  
A valmont COMPANY

DRAWING AND CONTENTS ARE COPYRIGHT TO INGAL CIVIL PRODUCTS AND CAN ONLY BE USED WITH PRIOR WRITTEN CONSENT FROM INGAL CIVIL PRODUCTS

157-85 AIRDS ROAD  
MINTO, N.S.W 2566

PH. +61 2 9827 3333  
www.ingalcivil.com.au

PROJECT	TITLE
	EZY-GUARD 4 ASSEMBLY DETAIL - SHEET 1 of 2

INGAL CIVIL PRODUCTS PART No.	DRAWING No.
	EZY-SM-116

Rev: 1

F:\ENGINEERING\SALES & MARKETING\DRAWINGS\EZY-GUARD ASSEMBLY\EZY-SM-116 - EZY-GUARD 4 ASSEMBLY.DWG



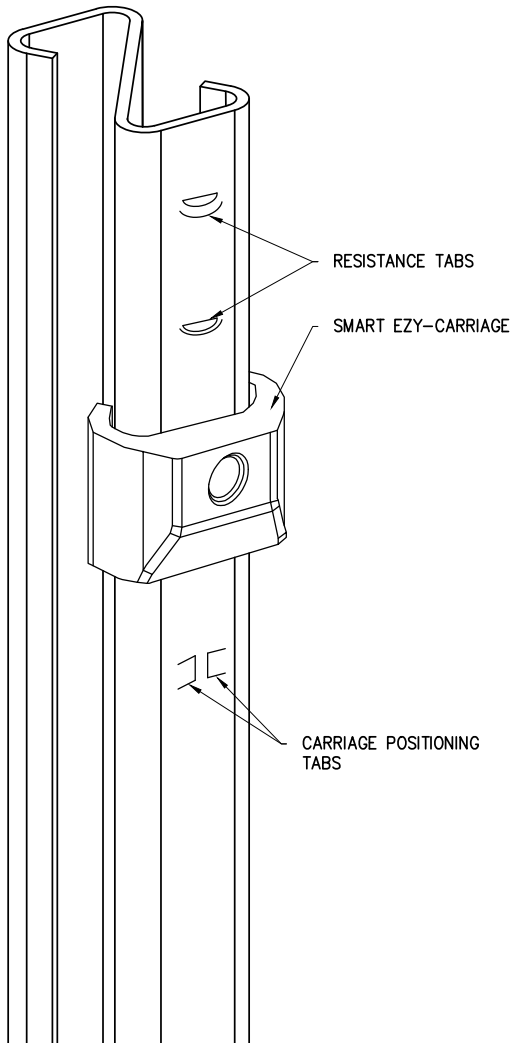

Z-POST & CARRIAGE ASSEMBLY  
ISOMETRIC VIEW

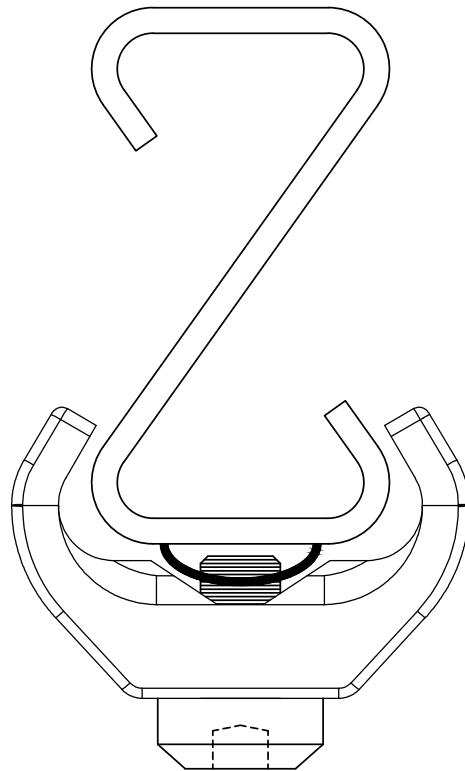

Z-POST & CARRIAGE ASSEMBLY  
PLAN VIEW

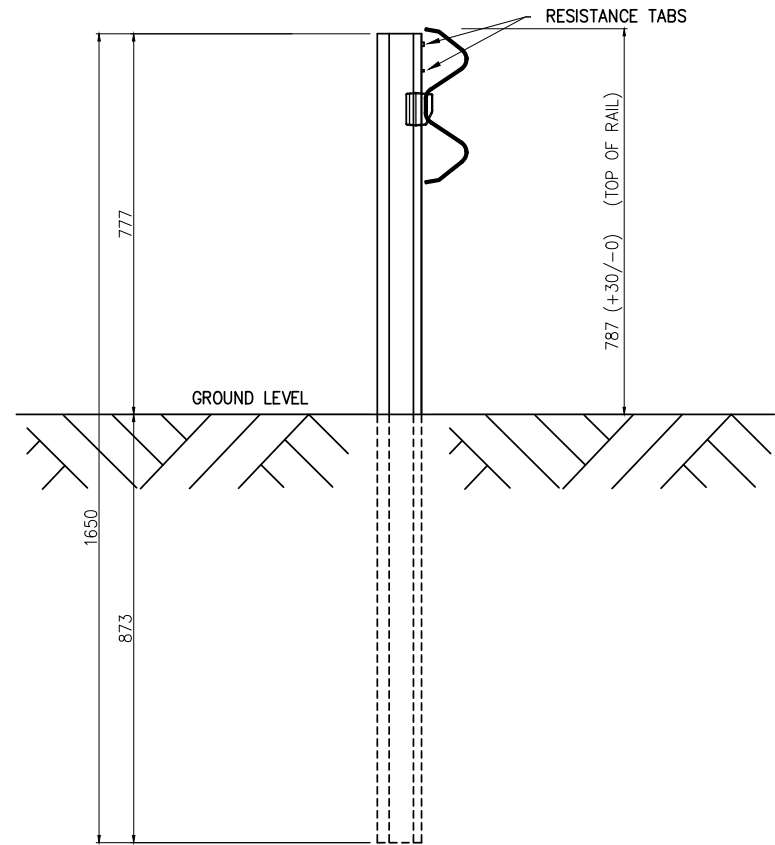

Z-POST & CARRIAGE ASSEMBLY  
SIDE VIEW

TO BE READ IN CONJUNCTION WITH EZY-SM-116

REV	DATE	DESCRIPTION	DRAWN	CHECKED	APPROVED	DRAWING NUMBER	REFERENCE DRAWINGS	NAME	DATE	PROJECT	INGAL CIVIL PRODUCTS PART No.
6	25-11-2019	REFERENCE DRAWING UPDATED	VB	LG	LG			DRAWN	DJB	01-12-2014	INGAL CIVIL PRODUCTS PART No.
5	02-07-2018	TOP OF RAIL HEIGHT TOLERANCE UPDATED	VB	LG	LG			CHECKED	LG	10-12-2014	
4	02-03-2016	TOLERANCE ADDED	LG					APPROVED			DRAWING No. EZY-SM-034
3	01-04-2015	NAME CHANGE (4)	LG	LG	LG			SCALE	N.T.S. @	A3	
2	13-07-2015	DIM MOD	DJB	LG	LG			ISSUE FOR	INFORMATION ONLY		Rev: 6
1	11-12-2014	DIM CORRECTION	DJB	LG							



DRAWING AND CONTENTS ARE COPYRIGHT TO  
INGAL CIVIL PRODUCTS AND CAN ONLY BE USED  
WITH PRIOR WRITTEN CONSENT FROM INGAL CIVIL  
PRODUCTS  
57-65 AIRDS ROAD  
MINTO, N.S.W 2566  
PH. +61 2 9827 3333  
www.ingalcivil.com.au

F:\ENGINEERING\S&S & MARKETING\DRAWINGS\EZY-GUARD ASSEMBLY\EZY-SM-034-EZY-GUARD 4-RTM1.DWG

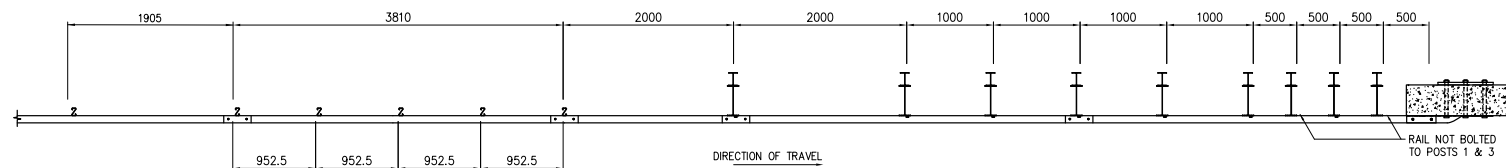

PLAN SCALE

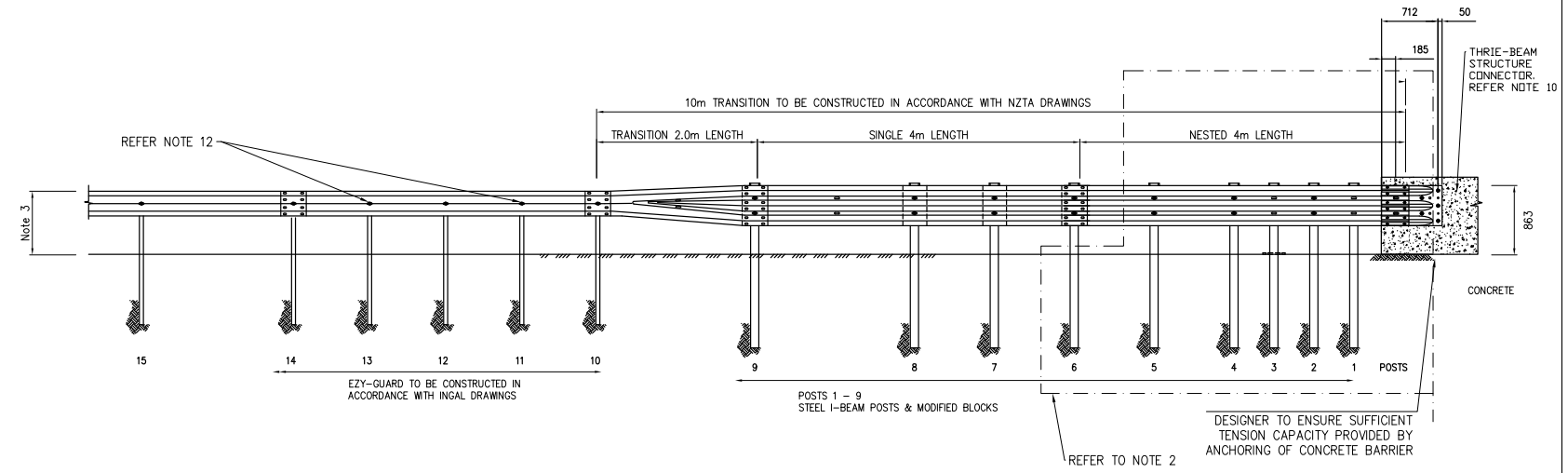

BILL OF MATERIALS - 10m Transition - 10007252		
PART NO	DESCRIPTION	QTY
10004016	THRIE-BEAM STEEL POSTS	9
10004017	MODIFIED STEEL BLOCKS - THRIE-BEAM	9
10001346	M16 X 50 MM HEX HEAD BOLT AND NUT	19
10001255	M16 X GALV SPRING WASHER	19
10000853	4.00M X 2.7 MM APPROACH THRIE-BEAM RAIL	3
10000871	STIFFENER 300 MM THRIE-BEAM RAIL	2
10000869	2M TRANSITION THRIE-BEAM	1
10001233	M16 X 50 MM POST BOLTS	10
10001248	M16 X 32 MM SPLICE BOLTS	24
10001239	M16 OVERSIZE NUTS	28
10001239	M16 OVERSIZE NUTS	34
10004528	M16 - 50 X 50 MM SQUARE FLAT WASHER	10
10006519	Terminal Concrete Connector Thriebeam	1
10006452	Thriebeam Burried in Backslope Concrete Bracket	1
10006453	Thriebeam Burried in Backslope Brkt Template	1
10006470	M24 x 50 mm Hex bolt and Nut	5
10001280	M24 x 3 mm Round Washer	5

BILL OF MATERIALS - 6m Transition - 10007737		
PART NO	DESCRIPTION	QTY
10004016	THRIE-BEAM STEEL POSTS	3
10004017	MODIFIED STEEL BLOCKS - THRIE-BEAM	3
10001346	M16 X 50 MM HEX HEAD BOLT AND NUT	9
10001255	M16 X GALV SPRING WASHER	9
10000853	4.00M X 2.7 MM APPROACH THRIE-BEAM RAIL	1
10000871	STIFFENER 300 MM THRIE-BEAM RAIL	2
10000869	2M TRANSITION THRIE-BEAM	1
10001233	M16 X 50 MM POST BOLTS	4
10001248	M16 X 32 MM SPLICE BOLTS	24
10001239	M16 OVERSIZE NUTS	28
10004528	M16 - 50 X 50 MM SQUARE FLAT WASHER	4
10006519	Thriebeam NZ Terminal Connector	1
10001336	M16 Hex Nut Galv	7
10006519	Terminal Concrete Connector Thriebeam	1
10006452	Thriebeam Burried in Backslope Concrete Bracket	1
10006453	Thriebeam Burried in Backslope Brkt Template	1
10006470	M24 x 50 mm Hex bolt and Nut	5
10001280	M24 x 3 mm Round Washer	5

NOTES:

- TO BE READ IN CONJUNCTION WITH THE NZTA DRAWING RSB-5.
- AS PER RSB-5, TRAILING TRANSITIONS INSTALLED ON ROADS DIVIDED BY MEDIAN BARRIER MAY HAVE THE ENTIRE NESTED THRIE-BEAM SECTION WITH POSTS 1 THROUGH 6, POSTS 11 AND 13 OMITTED.
- W BEAM HEIGHT TO BE IN ACCORDANCE WITH SYSTEM WEIGHT. I.E. Ezy-Guard 4 = 787mm, Ezy-Guard Smart = 730mm.
- THE MINIMUM TRANSITION LENGTH FOR W-SECTION TO CONCRETE IS 10.0m.
- ALL TRANSITION POSTS TO BE STEEL WITH MODIFIED BLOCKOUTS AS PER ALL TRANSITION POSTS TO BE STEEL WITH MODIFIED BLOCKOUTS AS PER NZ TRANSPORT AGENCY DRAWING B3.
- WHERE PROPER POST EMBEDMENT CANNOT BE ACHIEVED, STANDARD 'I' WHERE PROPER POST EMBEDMENT CANNOT BE ACHIEVED, STANDARD 'I' BEAM BRIDGE STEEL POSTS ON STEEL BASE PLATES (AS PER APPENDIX B NZ TRANSPORT AGENCY BRIDGE MANUAL) CAN BE BOLTED TO A CONCRETE BEAM.
- THRIE-BEAM RAIL & POST BOLT HOLES ARE TO BE AT 1000mm CENTERS.
- POSTS 7 & 8 NEED TO HAVE BACKING PIECES. POSTS 7 & 8 NEED TO HAVE BACKING PIECES.
- TRAILING TRANSITIONS INSTALLED ON ROADS DIVIDED BY MEDIAN BARRIER MAY HAVE THE ENTIRE NESTED THRIE-BEAM SECTION WITH ENTIRE NESTED THRIE-BEAM SECTION WITH NESTED THRIE-BEAM SECTION WITH POSTS 1 THRU 6 OMITTED.
- THRIE-BEAM STRUCTURE CONNECTOR TO BE FIXED USING 6 x GRADE 8.8/S M24 BOLTS THROUGH 30 HOLES IN CONCRETE BARRIER WITH A FULLBOLT PATTERN BACKING PLATE (16mm THICK 250MPa PL) FOR CAST-IN BRACKET, REFER TO NZ TRANSPORT AGENCY STANDARD DETAIL B8-2.
- FOR THRIE-BEAM ACROSS STRUCTURES REFER TO NZ TRANSPORT FOR THRIE-BEAM ACROSS STRUCTURES REFER TO NZ TRANSPORT AGENCY DRAWING B3.
- POSTS 11 AND 13 NOT BOLTED TO RAIL.

REV	DATE	DESCRIPTION	DRAWN	CHECKED	APPROVED
I	31-01-2019	UPDATED DIMENSION - BOM CLARIFICATION	VB	LG	LG
H	17/12/2018	UPDATED DIMENSION FOR CONCRETE BRACKET HEIGHT	VB	LG	LG
G	17/09/2018	NOTE 2 UPDATED AND NOTE 12 ADDED	VB	LG	LG
F	11/04/2018	NZTA NOTES ADDED AND DIMENSIONS CHANGED	WD	LG	LG
E	17/01/2018	BOM AM ADDED	WD	LG	LG
D	19/08/2015	BOM ADDED	MC	LG	LG
C	09/02/2015	SMART > 4	LG	SE	LG
B	09/10/2012	ISSUED FOR INFORMATION	DM	TC	

REV	DATE	DESCRIPTION	DRAWN	CHECKED	APPROVED

DRAWING NUMBER	REFERENCE DRAWINGS

	NAME	DATE
DRAWN	AUSTEC	16/12/2011
CHECKED	LG	9/02/2015
APPROVED	LG	9/02/2015
SCALE	NTS	
SIZE	A1	

INGAL CIVIL PRODUCTS  
57-65 AIRDS ROAD  
MINTO, N.S.W.  
AUSTRALIA 2566  
PH +61 2 9827 3333  
FAX +61 2 9827 3300  
www.ingalcivil.com.au

PROJECT EZY-GUARD	TITLE CONNECTION TO NZTA TL4 10m TRANSITION
----------------------	---

INGAL CIVIL PRODUCTS REFERENCE No.	DRAWING No. EZY-SM-025 REV. I
---------------------------------------	-------------------------------------

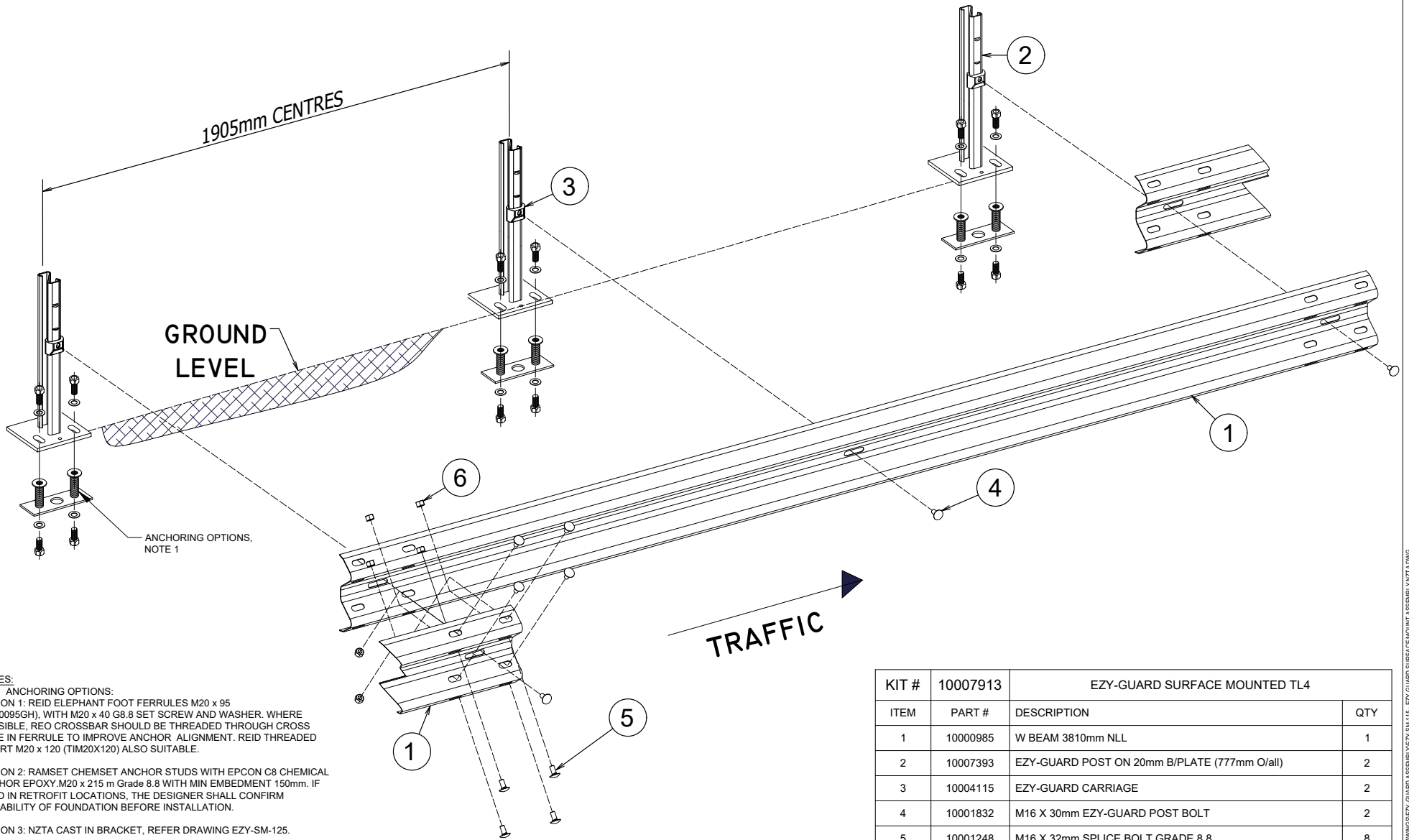

**NOTES:**

1. ANCHORING OPTIONS:  
 OPTION 1: REID ELEPHANT FOOT FERRULES M20 x 95 (FE20095GH), WITH M20 x 40 G8.8 SET SCREW AND WASHER. WHERE POSSIBLE, REO CROSSBAR SHOULD BE THREADED THROUGH CROSS HOLE IN FERRULE TO IMPROVE ANCHOR ALIGNMENT. REID THREADED INSERT M20 x 120 (TIM20X120) ALSO SUITABLE.

OPTION 2: RAMSET CHEMSET ANCHOR STUDS WITH EPCON C8 CHEMICAL ANCHOR EPOXY.M20 x 215 m Grade 8.8 WITH MIN EMBEDMENT 150mm. IF USED IN RETROFIT LOCATIONS, THE DESIGNER SHALL CONFIRM SUITABILITY OF FOUNDATION BEFORE INSTALLATION.

OPTION 3: NZTA CAST IN BRACKET, REFER DRAWING EZY-SM-125.

2. FOR DETAILS ON CONCRETE GROUND BEAM, PLEASE CONTACT YOUR LOCAL INGAL REPRESENTATIVE.

KIT #	10007913	EZY-GUARD SURFACE MOUNTED TL4	
ITEM	PART #	DESCRIPTION	QTY
1	10000985	W BEAM 3810mm NLL	1
2	10007393	EZY-GUARD POST ON 20mm B/PLATE (777mm O/all)	2
3	10004115	EZY-GUARD CARRIAGE	2
4	10001832	M16 X 30mm EZY-GUARD POST BOLT	2
5	10001248	M16 X 32mm SPLICE BOLT GRADE 8.8	8
6	10001239	M16 OVERSIZE NUT	8

REV	DATE	DESCRIPTION	DRAWN	CHECKED	APPROVED	DRAWING NUMBER	REFERENCE DRAWINGS	NAME	DATE	PROJECT	INGAL CIVIL PRODUCTS PART No.
2	02-12-2019	PARTS LIST UPDATED, NOTES AND ANCHORING OPTIONS ADDED.	VB	BS	LG			MC	25-08-15	INGAL CIVIL PRODUCTS A valmont COMPANY	10007913
1	31-03-16	CAST-IN ASSEMBLY REDRAWN, BOM UPDATED	MC	SE	LG			SE	25-08-15		DRAWING No.
								SCALE	N.T.S. @ A3	EZY GUARD 4 NZTA SURFACE MOUNT ASSEMBLY DETAIL 1 OF 2	
								ISSUE FOR	INFORMATION ONLY	Rev. 2	

ENGINEERING SALES & MARKET INCORPORATING EZY-GUARD ASSEMBLY EZY-SM-115 - EZY GUARD SURFACE MOUNT ASSEMBLY NZTA DWG

Release 12/19

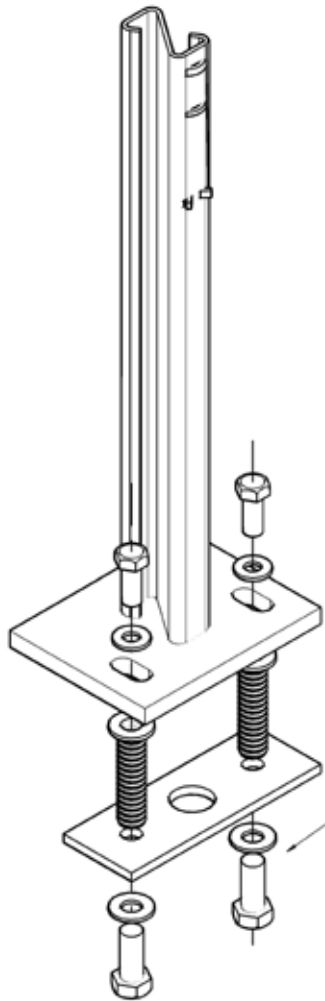

ANCHORING OPTIONS, NOTE 6

BILL OF MATERIALS		
PART DESCRIPTION	QTY	PART NO.
Z-Post on B/P (720mm) OR	1	10007408
Ezy-Guard 4 Z-Post (777mm)	1	10007393
M20 x 50 Hex Head	2	10006180
BOTTOM PLATE	1	10007626
M20 CAST-IN SOCKET	2	10006516
M24 X 50 HEX BOLT	2	10006470
M24 ROUND FLAT WASHER	2	10001227

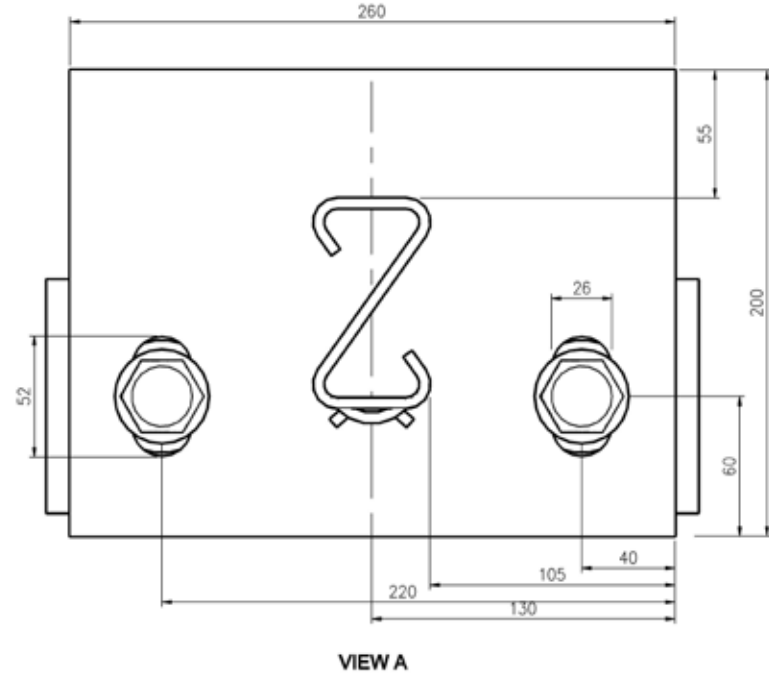
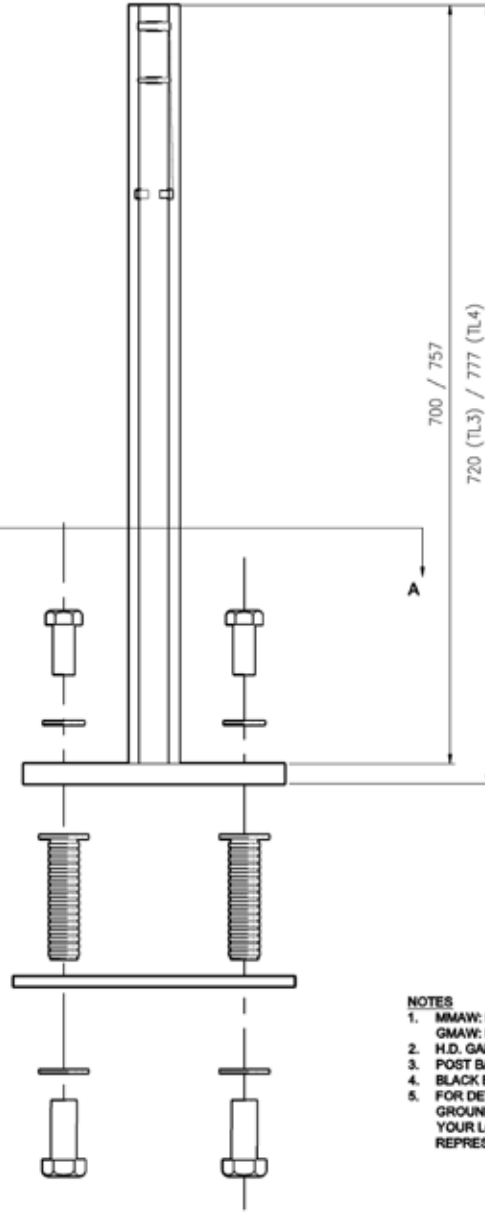

VIEW A

NOTES

- MMAW: E49xx electrode (AS/NZS 4855)  
GMAW: B-T49 wire (AS/NZS ISO 17632)
- H.D. GALV TO AS/NZS 4680
- POST BASE PLATE: HA250
- BLACK BASEPLATE: 10007391
- FOR DETAILS ON CONCRETE GROUND BEAM, PLEASE CONTACT YOUR LOCAL INGAL REPRESENTATIVE.

NOTES CONTINUED:

- ANCHORING OPTIONS:
  - OPTION 1: REID ELEPHANT FOOT FERRULES M20 x 95 (FE20095GH), WITH M20 x 40 G8.8 SET SCREW AND WASHER. WHERE POSSIBLE, REID CROSSBAR SHOULD BE THREADED THROUGH CROSS HOLE IN FERRULE TO IMPROVE ANCHOR ALIGNMENT. REID THREADED INSERT M20 x 120 (TIM20X120) ALSO SUITABLE.
  - OPTION 2: RAMSET CHEMSET ANCHOR STUDS WITH EPICON C8 CHEMICAL ANCHOR EPOXY M20 x 215 m Grade 8.8 WITH MIN EMBEDMENT 150mm. IF USED IN RETROFIT LOCATIONS, THE DESIGNER SHALL CONFIRM SUITABILITY OF FOUNDATION BEFORE INSTALLATION.
  - OPTION 3: NZTA CAST IN BRACKET, REFER DRAWING EZY-SM-125.

REV	DATE	DESCRIPTION	DRAWN	CHECKED	APPROVED
8	02-12-2019	TITLE BLOCK UPDATED, NOTES 5 AND 6 ADDED.	VB	LG	LG
7	06-02-2017	12mm DIA HOLES REMOVED, SOCKET AMENDED	MC	SE	LG
6	31-03-2016	CAST-IN BRACKET REPLACED, BOM ADDED	MC	SE	LG
5	03-05-2016	WAS 777mm O.A. DRAWING	LG	MC	LG
4	13-09-2016	QIM ADOPTION	LG	SE	LG
3	21-01-2016	PART NUMBERS ADDED & HEIGHT INCREASE	LG	SE	LG
2	12-01-2015	DIMENSION ADD	LG	SE	LG
1	12-01-2015	WELD DETAIL ADDED	LG	SE	LG

REV	DATE	DESCRIPTION	DRAWN	CHECKED	APPROVED
8	02-12-2019	TITLE BLOCK UPDATED, NOTES 5 AND 6 ADDED.	VB	LG	LG
7	06-02-2017	12mm DIA HOLES REMOVED, SOCKET AMENDED	MC	SE	LG
6	31-03-2016	CAST-IN BRACKET REPLACED, BOM ADDED	MC	SE	LG
5	03-05-2016	WAS 777mm O.A. DRAWING	LG	MC	LG
4	13-09-2016	QIM ADOPTION	LG	SE	LG
3	21-01-2016	PART NUMBERS ADDED & HEIGHT INCREASE	LG	SE	LG
2	12-01-2015	DIMENSION ADD	LG	SE	LG
1	12-01-2015	WELD DETAIL ADDED	LG	SE	LG

REV	DATE	DESCRIPTION	DRAWN	CHECKED	APPROVED
8	02-12-2019	TITLE BLOCK UPDATED, NOTES 5 AND 6 ADDED.	VB	LG	LG
7	06-02-2017	12mm DIA HOLES REMOVED, SOCKET AMENDED	MC	SE	LG
6	31-03-2016	CAST-IN BRACKET REPLACED, BOM ADDED	MC	SE	LG
5	03-05-2016	WAS 777mm O.A. DRAWING	LG	MC	LG
4	13-09-2016	QIM ADOPTION	LG	SE	LG
3	21-01-2016	PART NUMBERS ADDED & HEIGHT INCREASE	LG	SE	LG
2	12-01-2015	DIMENSION ADD	LG	SE	LG
1	12-01-2015	WELD DETAIL ADDED	LG	SE	LG

INGAL CIVIL PRODUCTS  
A valmont COMPANY

DRAWING AND CONTENTS ARE COPYRIGHT TO INGAL CIVIL PRODUCTS AND CAN ONLY BE USED WITH PRIOR WRITTEN CONSENT FROM INGAL CIVIL PRODUCTS

57-65 AIRDS ROAD MINTO, N.S.W 2566 PH. +61 2 9827 3333 www.ingalcivil.com.au

REV	DATE	DESCRIPTION	DRAWN	CHECKED	APPROVED
8	02-12-2019	TITLE BLOCK UPDATED, NOTES 5 AND 6 ADDED.	VB	LG	LG
7	06-02-2017	12mm DIA HOLES REMOVED, SOCKET AMENDED	MC	SE	LG
6	31-03-2016	CAST-IN BRACKET REPLACED, BOM ADDED	MC	SE	LG
5	03-05-2016	WAS 777mm O.A. DRAWING	LG	MC	LG
4	13-09-2016	QIM ADOPTION	LG	SE	LG
3	21-01-2016	PART NUMBERS ADDED & HEIGHT INCREASE	LG	SE	LG
2	12-01-2015	DIMENSION ADD	LG	SE	LG
1	12-01-2015	WELD DETAIL ADDED	LG	SE	LG

REV	DATE	DESCRIPTION	DRAWN	CHECKED	APPROVED
8	02-12-2019	TITLE BLOCK UPDATED, NOTES 5 AND 6 ADDED.	VB	LG	LG
7	06-02-2017	12mm DIA HOLES REMOVED, SOCKET AMENDED	MC	SE	LG
6	31-03-2016	CAST-IN BRACKET REPLACED, BOM ADDED	MC	SE	LG
5	03-05-2016	WAS 777mm O.A. DRAWING	LG	MC	LG
4	13-09-2016	QIM ADOPTION	LG	SE	LG
3	21-01-2016	PART NUMBERS ADDED & HEIGHT INCREASE	LG	SE	LG
2	12-01-2015	DIMENSION ADD	LG	SE	LG
1	12-01-2015	WELD DETAIL ADDED	LG	SE	LG

Rev: 8

F:\ENGINEERING\SALES & MARKETING\DRAWINGS\EZY-GUARD\ASSEMBLY\EZY-SM-125\_Z-POST BRACKET SPEC CAST IN ASSEMBLY.DWG



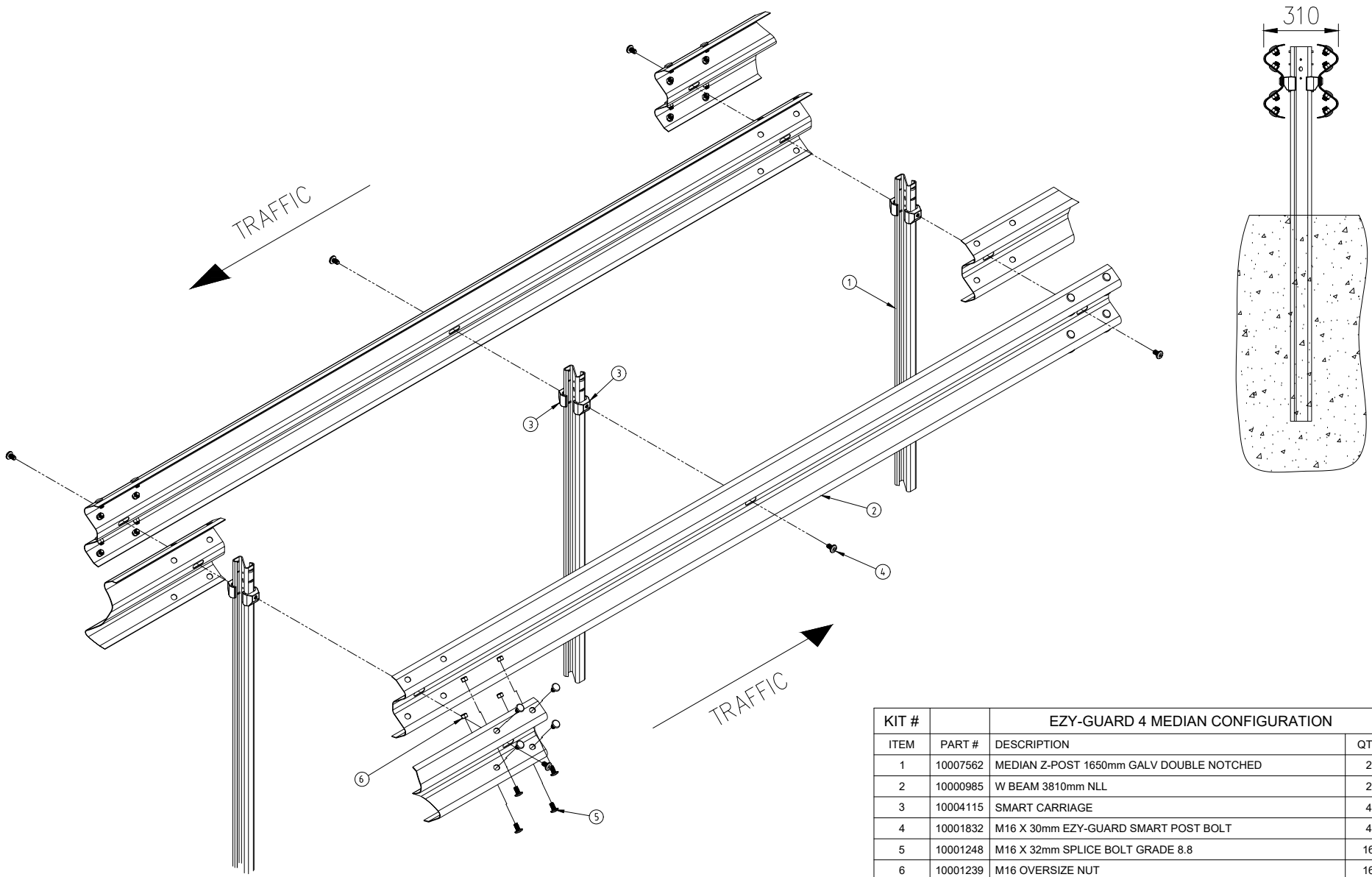

EZY-GUARD 4 MEDIAN CONFIGURATION			
KIT #			
ITEM	PART #	DESCRIPTION	QTY
1	10007562	MEDIAN Z-POST 1650mm GALV DOUBLE NOTCHED	2
2	10000985	W BEAM 3810mm NLL	2
3	10004115	SMART CARRIAGE	4
4	10001832	M16 X 30mm EZY-GUARD SMART POST BOLT	4
5	10001248	M16 X 32mm SPLICE BOLT GRADE 8.8	16
6	10001239	M16 OVERSIZE NUT	16

REV	DATE	DESCRIPTION	DRAWN	CHECKED	APPROVED
5	28-11-2019	PART LIST AND TITLE BLOCK UPDATED	VB	BS	LG
4	02-03-2016	FOOTPRINT DIM ADDED	LG	SE	LG
3	03-12-2015	ALL REFERENCE REMOVED	LG	SE	LG
2	10-04-16	TITLE CHANGE	LG	SE	LG
1	01-04-16	TITLE CHANGE	LG	SE	LG

REV	DATE	DESCRIPTION	DRAWN	CHECKED	APPROVED

	NAME	DATE
DRAWN	AUSCOL	03-02-2015
CHECKED	LG	04-02-2015
APPROVED	LG	04-02-2015
SCALE	N.T.S. @	A3
ISSUE FOR	INFORMATION ONLY	

**INGAL CIVIL PRODUCTS**  
a valmont COMPANY

DRAWING AND CONTENTS ARE COPYRIGHT TO  
 INGAL CIVIL PRODUCTS AND CAN ONLY BE USED  
 WITH PRIOR WRITTEN CONSENT FROM INGAL CIVIL  
 PRODUCTS

57-65 AIRDS ROAD  
 MINTO, N.S.W. 2566

PH. +61 2 9827 3333  
 www.ingalcivil.com.au

PROJECT	
TITLE	EZY-GUARD 4 MEDIAN CONFIGURATION

INGAL CIVIL PRODUCTS PART No.	N/A
DRAWING No.	EZY-SM-035
Rev.	5

P: ENGINEERING SALES & MARKETING DRAWINGS/EZY-GUARD ASSEMBLY/EZY-SM-035 - EZY-GUARD 4 MEDIAN CONFIGURATION - 3810MM.DWG

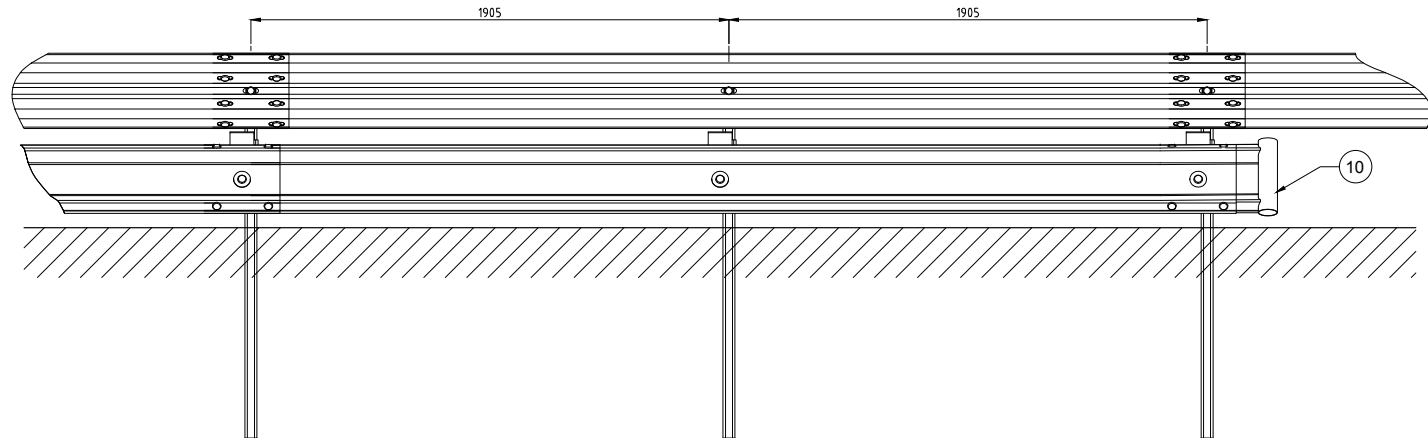
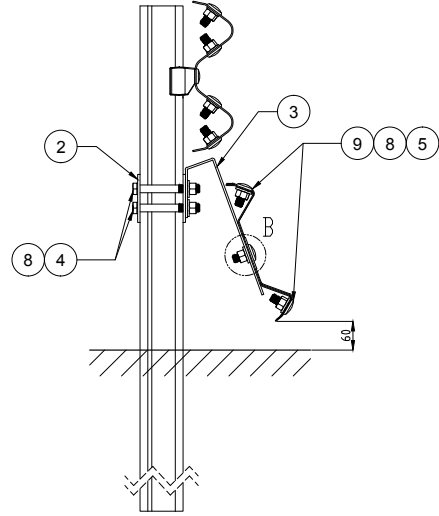
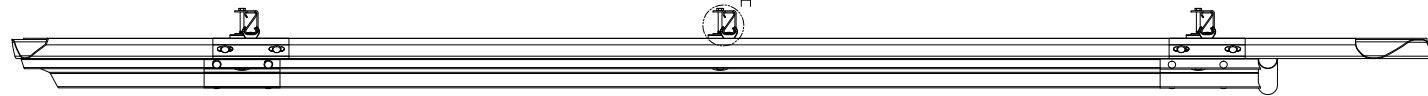
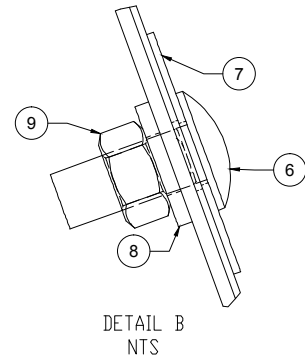
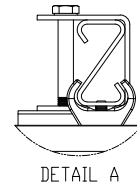
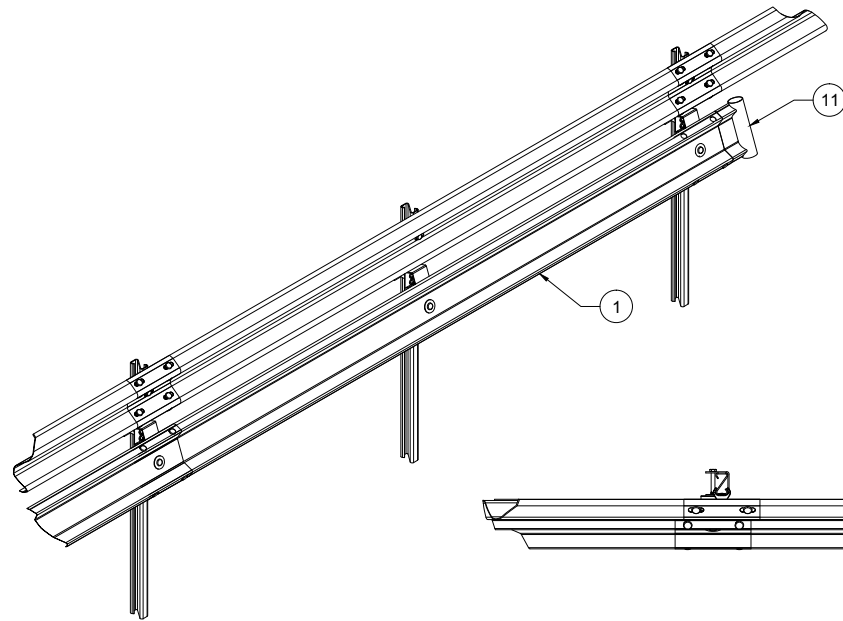

EZY-GUARD CONFIG - MPR BILL OF MATERIALS (3.81m)			
ITEM	QTY	PART NUMBER	DESCRIPTION
1	1	10007769	Motorcyclist protection beam
2	2	10007332	Z-Post Bracket
3	2	10006772	Rail mounting bracket
4	4	10003618	M16x130 Hex bolt/nut
5	4	10001248	Round head bolt M16x32
6	2	10006769	Round head bolt M16x40
7	2	10006771	Slot Washer ø70x2
8	6	10006770	Washer ø35x17x4
9	6	10007834	M16 nut
10		10006767	MPR END TERMINAL

- NOTES:**
- ALL STEELWORK TO BE HOT DIP GALVANISED AFTER FABRICATION TO AS/NZS 4680 AND STRAIGHTENED AFTER GALVANISING IF REQUIRED.
  - TO BE READ IN CONJUNCTION WITH EZY-GUARD PRODUCT MANUAL

REV	DATE	DESCRIPTION	DRAWN	CHECKED	APPROVED	DRAWING NUMBER	REFERENCE DRAWINGS
3	22-11-16	WASHER QTY REDUCED	MC	LG	MC		
2	31-08-16	PART NUMBERS AND LABELS ADDED TO DRAWING	MC	LG	MC		
1	20-07-2015	BOM CORRECTION - ITEM 10	LG	LG	MC		

NAME	DATE
DRAWN A.R.	29/10/2015
CHECKED LG	29/10/2015
APPROVED	
SCALE	N.T.S. @ A3
ISSUE FOR	INFORMATION ONLY

PROJECT	INGAL CIVIL PRODUCTS 57-65 AIRDS ROAD MINTO, N.S.W. AUSTRALIA 2566 PH: +61 2 9827 3333 FAX: +61 2 9827 3300 www.ingalcivil.com.au	INGAL CIVIL PRODUCTS PART No. 10007895
TITLE	INGAL MPR MOTORCYCLIST PROTECTION 3.81m EZY-GUARD CONFIGURATION ASSEMBLY DETAILS	DRAWING No. ICP-MPR-007

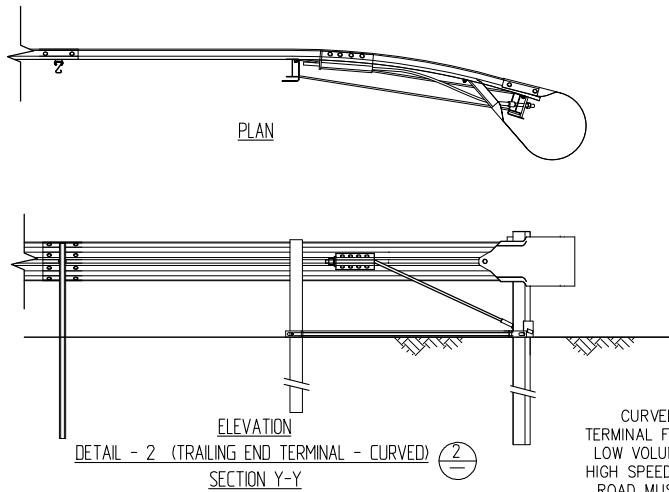
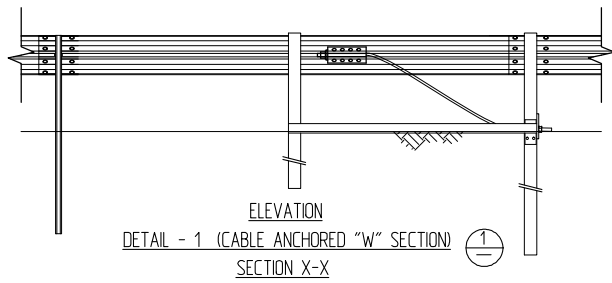
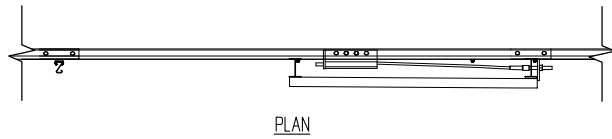
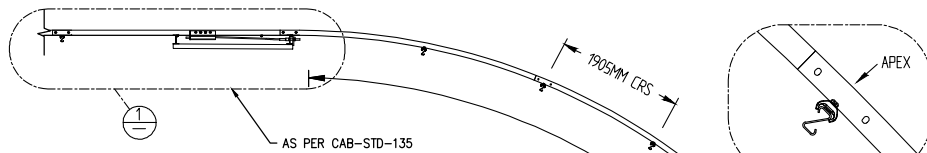

CURVED TRAILING END TERMINAL FOR LOW SPEED, LOW VOLUME ROAD ONLY. HIGH SPEED, HIGH VOLUME ROAD MUST BE AN NZTA APPROVED ET2000 PLUS END TERMINAL.

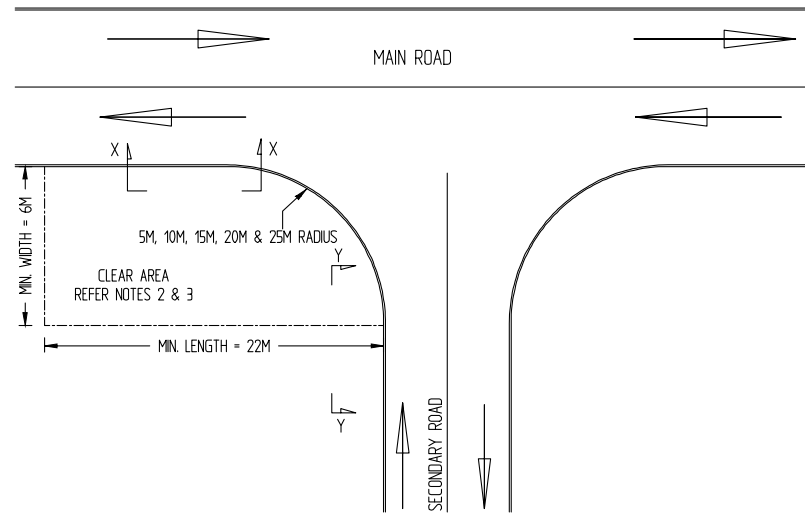
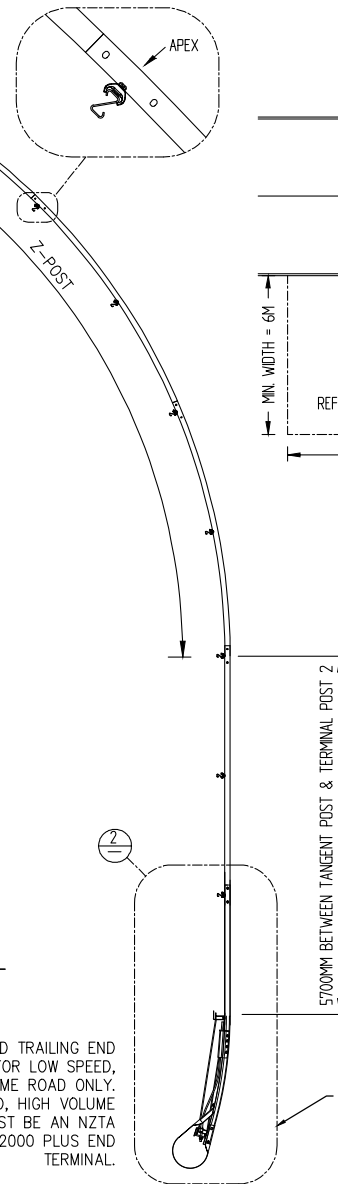

NOTES:

1. APPROACH GRADING IS TO BE 10H:1V OR FLATTER. MAINTAIN FREE OF OBSTRUCTIONS.
2. A MINIMUM CLEAR ZONE OF 22m x 6m TO BE PROVIDED BEHIND THE GUARDRAIL.
3. CLEAR ZONE BEHIND GUARDRAIL TO BE 6H:1V OR FLATTER AND MAINTAINED FREE OF OBSTRUCTIONS.
4. FASTENER CONFIGURATION OF CURVED TERMINAL POSTS TO BE IDENTICAL TO LONGITUDINAL BARRIER POSTS.

REV	DATE	DESCRIPTION	DRAWN	CHECKED	APPROVED
0		ORIGINAL ISSUE	MC	SE	LG

DRAWING NUMBER	REFERENCE DRAWINGS

NAME	DATE
DRAWN MC	18-04-16
CHECKED SE	18-04-16
APPROVED LG	18-04-16
SCALE	N.T.S. @ A3
ISSUE FOR	

INGAL CIVIL PRODUCTS  
57-65 AIRDS ROAD  
MINTO, N.S.W.  
AUSTRALIA 2566  
PH. +61 2 9827 3333  
FAX +61 2 9827 3300  
www.ingalcivil.com.au

DRAWING AND CONTENTS ARE COPYRIGHT TO INGAL CIVIL PRODUCTS AND CAN ONLY BE USED WITH PRIOR WRITTEN CONSENT FROM INGAL CIVIL PRODUCTS

PROJECT	TITLE
	EZY-GUARD 4 NZTA CURVED TERMINAL GENERAL ARRANGEMENT

INGAL CIVIL PRODUCTS PART No.	DRAWING No.
EZY-SM-126	EZY-SM-126

Rev. 0

J:\SALES & MARKETING\DRAWINGS\EZY-GUARD ASSEMBLY\EZY-SM-126 - NZTA CURVED DRAWING TERMINAL.DWG

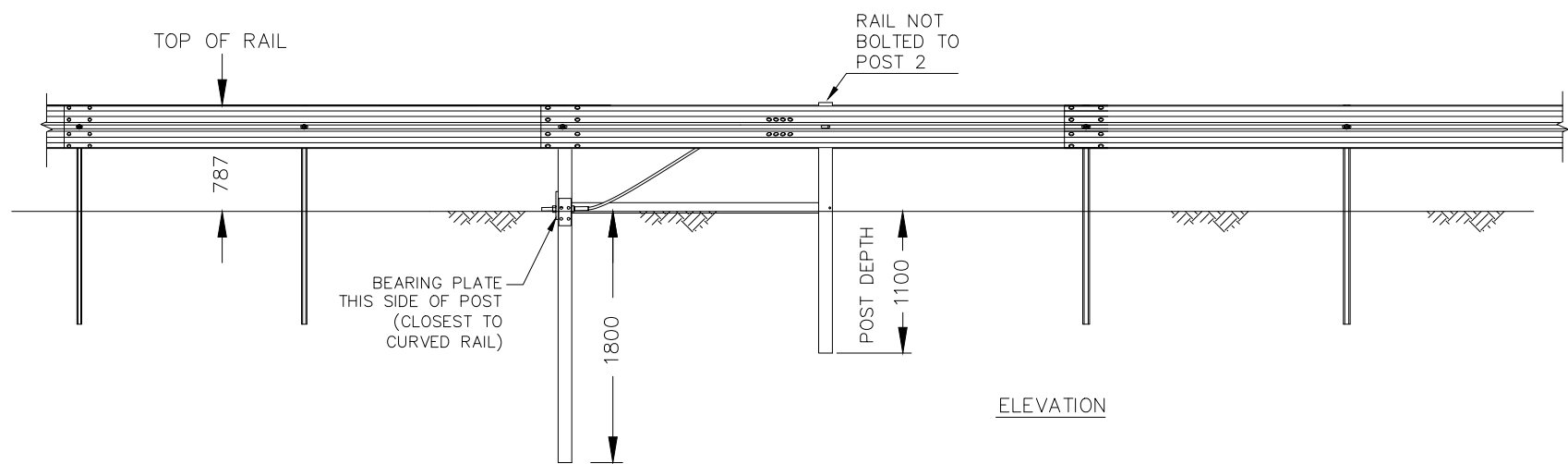
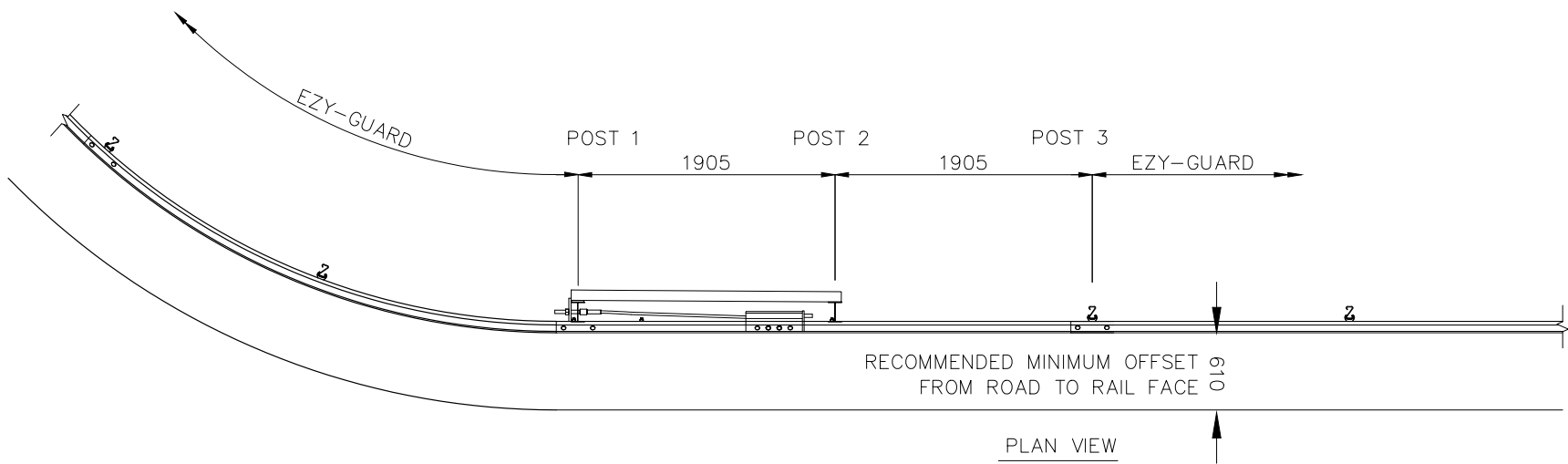

NOTE

1. DRAWING TO BE READ IN CONJUNCTION WITH CAB-STD-134 AND THE EZY-GUARD 4 MANUAL.

REV	DATE	DESCRIPTION	DRAWN	CHECKED	APPROVED	DRAWING NUMBER	REFERENCE DRAWINGS	NAME	DATE	PROJECT	INGAL CIVIL PRODUCTS PART No.																	
5	26-11-2019	PART NUMBER ADDED		VB	LG			AR	01-09-2015	<p>DRAWING AND CONTENTS ARE COPYRIGHT TO INGAL CIVIL PRODUCTS AND CAN ONLY BE USED WITH PRIOR WRITTEN CONSENT FROM INGAL CIVIL PRODUCTS</p> <p>57-46 AIRDS ROAD MINTO, N.S.W 2566 PH. +61 2 9827 3333 www.ingalcivil.com.au</p>	10007922																	
4	28-11-2016	CURVED RAIL ADDED		MC	LG			MC	16-09-2015																			
3	18-04-2016	NAME CHANGE		MC	LG			LG	16-09-2015																			
2	23-11-2015	POST 2 - BOLT REMOVED		MC	LG																							
1	23-11-2015	CABLE ASSEMBLY REDRAWN		MC	LG																							
<p>REVISIONS</p> <table border="1"> <thead> <tr> <th>REV</th> <th>DATE</th> <th>DESCRIPTION</th> <th>DRAWN</th> <th>CHECKED</th> <th>APPROVED</th> <th>DRAWING NUMBER</th> <th>REFERENCE DRAWINGS</th> </tr> </thead> <tbody> <tr> <td> </td> <td> </td> <td> </td> <td> </td> <td> </td> <td> </td> <td> </td> <td> </td> </tr> </tbody> </table>											REV	DATE	DESCRIPTION	DRAWN	CHECKED	APPROVED	DRAWING NUMBER	REFERENCE DRAWINGS									<p>TITLE</p> <p>EZY-GUARD 4 - INTERMEDIATE ANCHOR ELEVATION ASSEMBLY VIEW NZ SPEC</p>	<p>DRAWING No.</p> <p>CAB-STD-135</p>
REV	DATE	DESCRIPTION	DRAWN	CHECKED	APPROVED	DRAWING NUMBER	REFERENCE DRAWINGS																					
<p>SCALE N.T.S. @ A3</p> <p>ISSUE FOR</p>											<p>Rev 5</p>																	

E:\PROJECTS\INGAL\PC\A\LIBRARY\INGAL\PRODUCTS\CABLE ASSEMBLY\ASSEMBLY\STD-134-07.PPT\SUBSET\INTERMEDIATE ANCHOR - ELEVATION.DWG



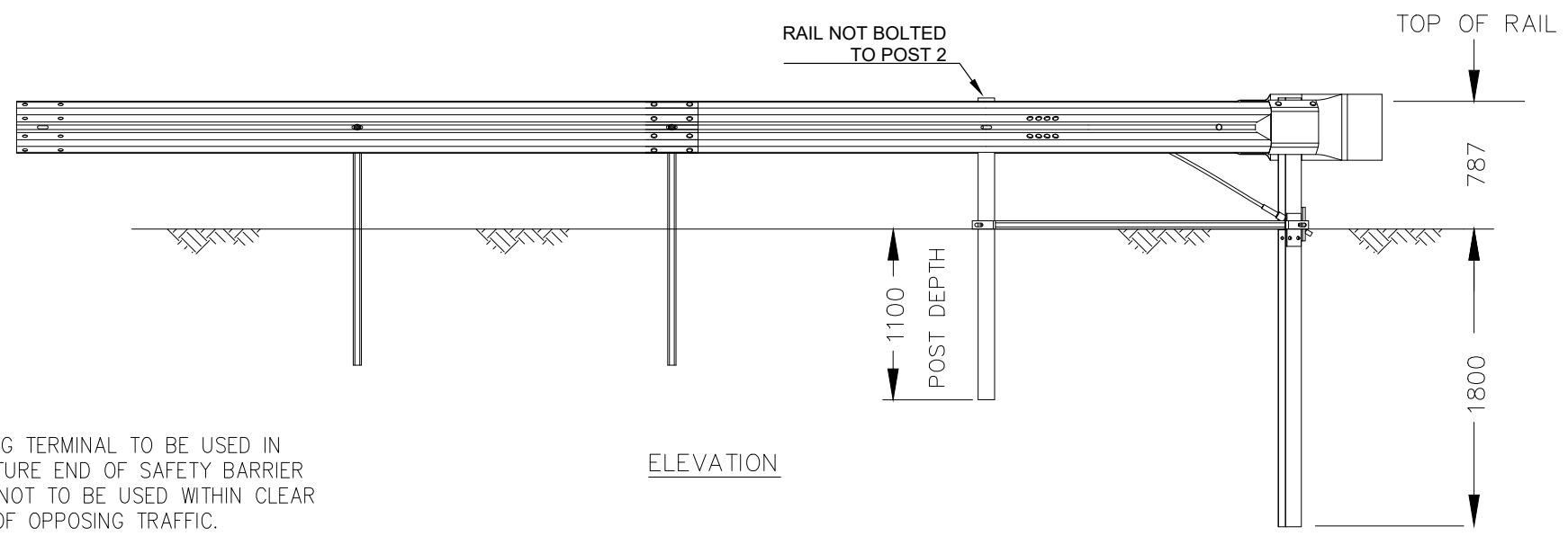
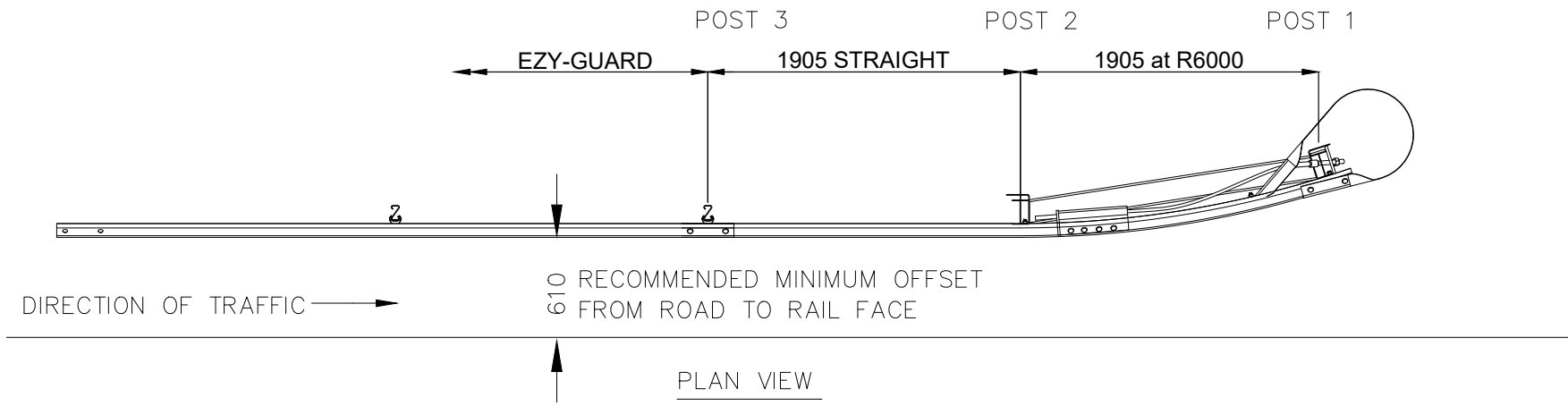

- NOTE**
1. TRAILING TERMINAL TO BE USED IN DEPARTURE END OF SAFETY BARRIER ONLY. NOT TO BE USED WITHIN CLEAR ZONE OF OPPOSING TRAFFIC.
  2. DRAWING TO BE READ IN CONJUNCTION WITH CAB-STD-129

REV	DATE	DESCRIPTION	DRAWN	CHECKED	APPROVED	DRAWING NUMBER	REFERENCE DRAWINGS	ISSUE FOR
3	26-11-2019	PART NUMBER ADDED	VB	BS	LG			
2	23-11-2015	POST 2 - BOLT REMOVE	MC	LG	LG			
1	23-11-2015	CABLE ASSEMBLY REDRAWN	MC	LG				

NAME	DATE
DRAWN AR	01-09-2015
CHECKED MC	16-09-2015
APPROVED LG	16-09-2015
SCALE N.T.S. @	A3

	<b>PROJECT</b> NZ TRAILING TERMINAL CURVED TERMINAL ASSEMBLY DETAIL	INGAL CIVIL PRODUCTS PART No. 10007924
DRAWING AND CONTENTS ARE COPYRIGHT TO INGAL CIVIL PRODUCTS AND CAN ONLY BE USED WITH PRIOR WRITTEN CONSENT FROM INGAL CIVIL PRODUCTS 57-65 AIRDS ROAD MINTO, N.S.W. 2566 PH. +61 2 9827 3333 www.ingalcivil.com.au	<b>TITLE</b> NZ TRAILING TERMINAL CURVED TERMINAL ASSEMBLY DETAIL	DRAWING No. CAB-STD-132

F:\ENGINEERING\SALES & MARKETING\ENGINEERING ARCHIVES\INDUSTRIAL STANDARDS\CAB-STD-132 - NZ TT CURVED - FRONT AND TOP ELEVATIONS.DWG

Item No.	Description - Ezy-Lift Retrofit Kit	Part No.	Qty
3	EZY-ABE Overlay Carriage HDG	10008353	1
4	M16 x 30mm Ezy-Guard Smart Post Bolt	10001832	1
7	M16 Round Washer	10001242	1
8	M16 Rectangular Washer 3mm	10001243	1

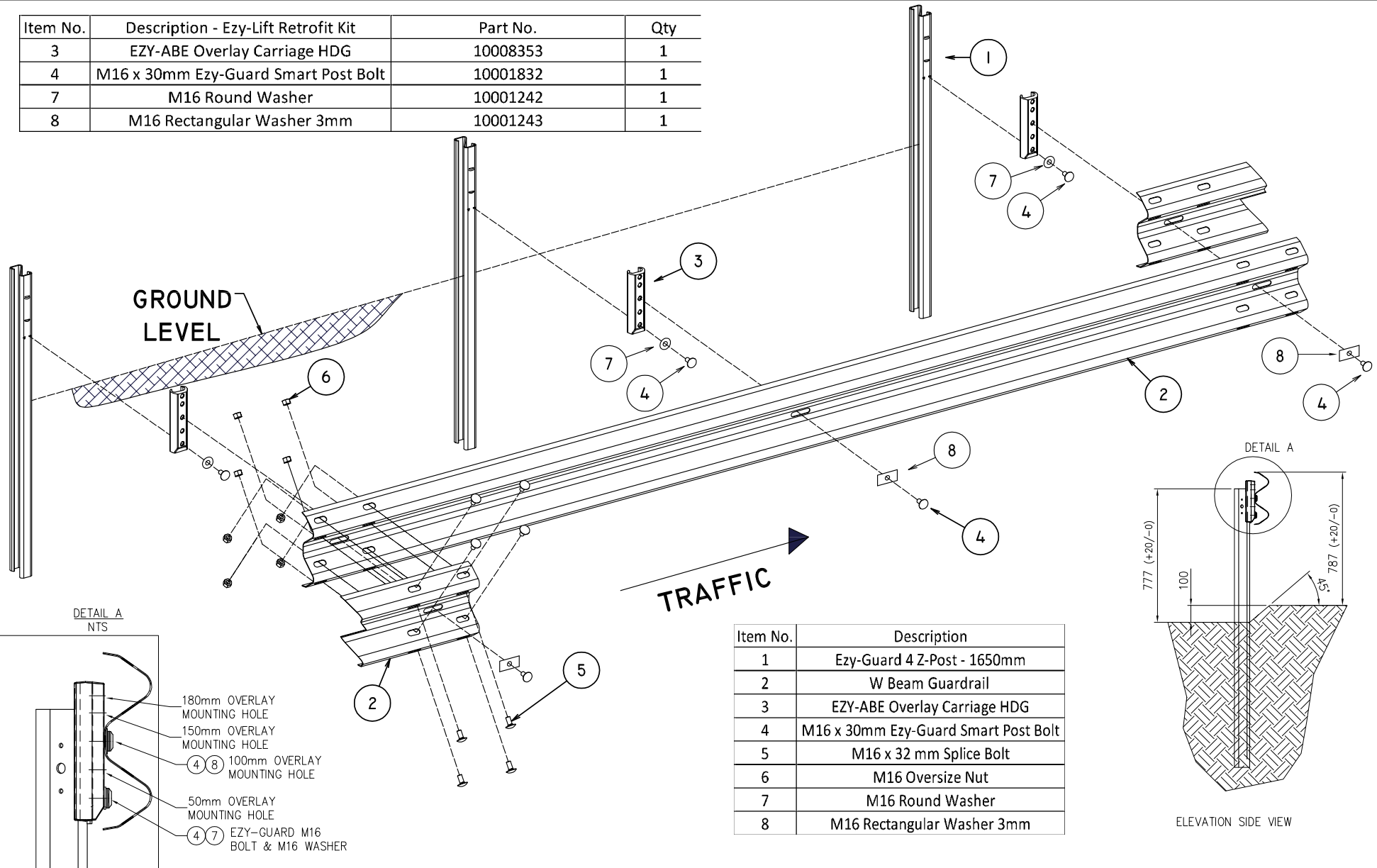

Item No.	Description
1	Ezy-Guard 4 Z-Post - 1650mm
2	W Beam Guardrail
3	EZY-ABE Overlay Carriage HDG
4	M16 x 30mm Ezy-Guard Smart Post Bolt
5	M16 x 32 mm Splice Bolt
6	M16 Oversize Nut
7	M16 Round Washer
8	M16 Rectangular Washer 3mm

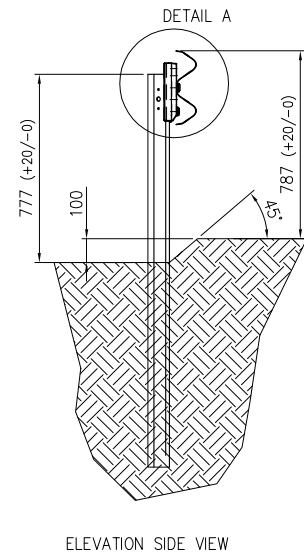

REV	DATE	DESCRIPTION	DRAWN	CHECKED	APPROVED
3	29-03-18	DETAIL A TABLE ADDED	WD	LG	
2	25-03-17	DRAWING TITLE UPDATED	MC	LG	
1	15-02-2017	PART NUMBER CORRECTION - LOWER CARRIAGE BOLT		LG	

REV	DATE	DESCRIPTION	DRAWN	CHECKED	APPROVED

NAME	DATE
DRAWN MC	13-12-16
CHECKED LG	13-12-16
APPROVED LG	13-12-16
SCALE N.T.S. @ A3	
ISSUE FOR INFORMATION ONLY	

**INGAL CIVIL PRODUCTS**  
a valmont COMPANY

DRAWING AND CONTENTS ARE COPYRIGHT TO  
 INGAL CIVIL PRODUCTS AND CAN ONLY BE USED  
 WITH PRIOR WRITTEN CONSENT FROM INGAL CIVIL  
 PRODUCTS

57-65 AIRDS ROAD  
 MINTO, N.S.W. 2566 PH. +61 2 9827 3333  
 www.ingalcivil.com.au

PROJECT	TITLE
	EZY-GUARD 4 WITH EZY-LIFT CARRIAGE EXPLODED ASSEMBLY DETAIL

INGAL CIVIL PRODUCTS PART No.	DRAWING No.
	EZY-SM-131

P4 DRAWINGS IN PROGRESS - WIP - VALLEY - SM-131 - EZY-LIFT EXPLODED ASSEMBLY - NZ ZPOST - 1650MM.DWG



**INGAL**  
CIVIL PRODUCTS  
A valmont  COMPANY

*For more information*

contact us on the web

[www.ingalcivil.co.nz](http://www.ingalcivil.co.nz)

**Auckland**

Orders: 09 920 6838

Bruce: 021 580 997

Richard: 021 877 653

Email: [sales@ingalcivil.co.nz](mailto:sales@ingalcivil.co.nz)

**Christchurch**

Ian: 021 198 3311

Steve: 021 480 753

**Wellington**

Brendon: 021 504 870