

D

C

B

A

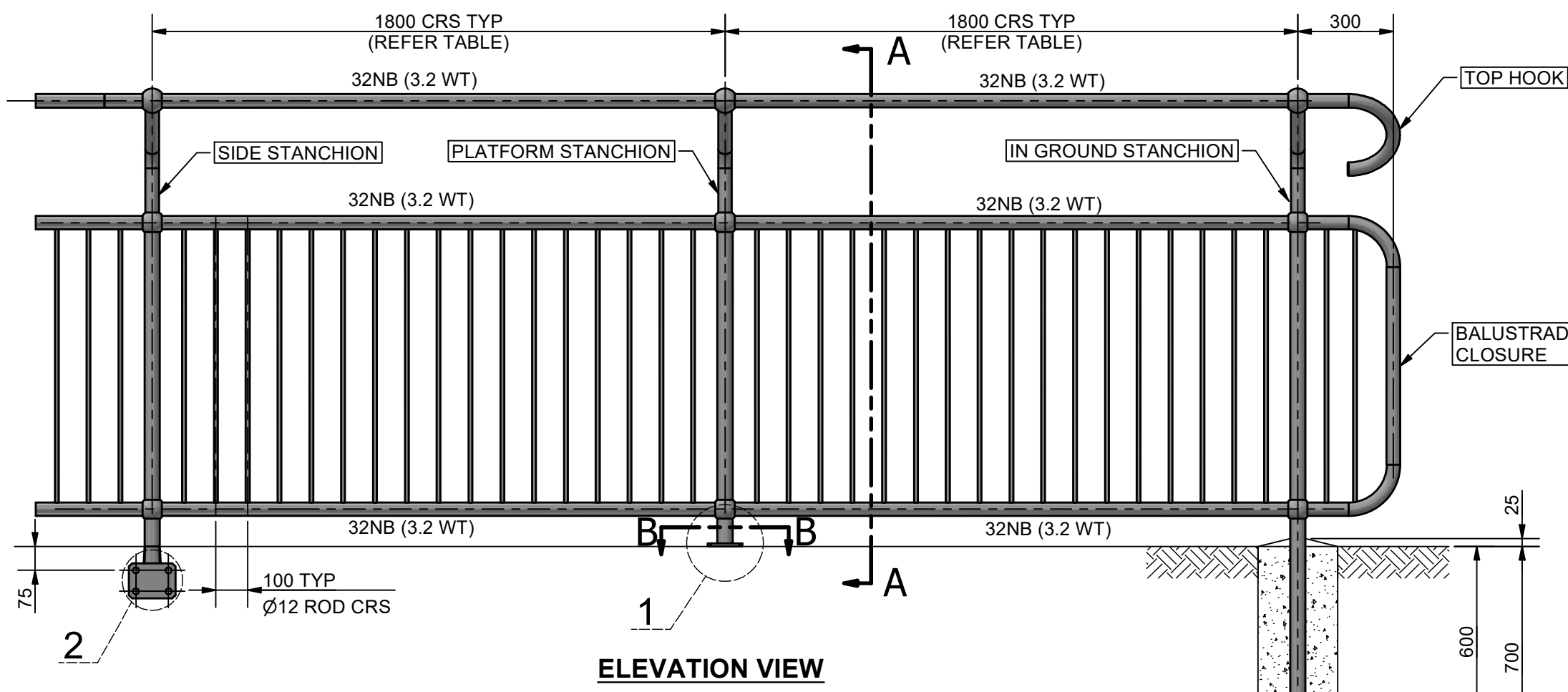

ELEVATION VIEW

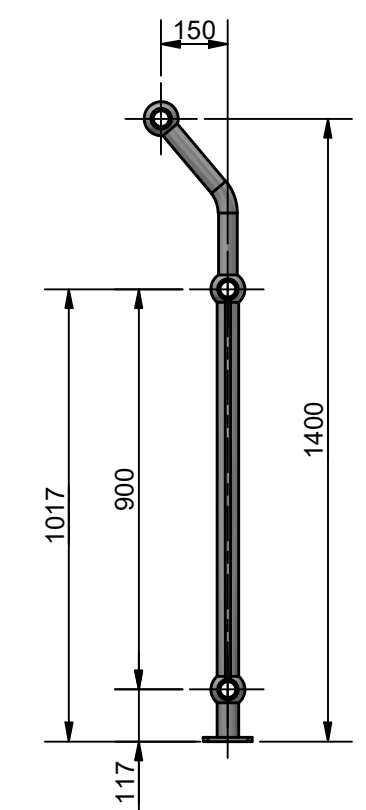

SECTION A-A

RECOMMENDED STANCHION SPACING		
STANDARD	LOADING	MAX CRS
AS/NZS 1657	0.35 kN/m	1.8 m *
AS/NZS 1170 (C3)	0.75 kN/m	1.65 m

*LONGER STANCHION SPACING MAY BE POSSIBLE THROUGH CONSULTATION WITH THE WEBFORGE LOCKER TECHNICAL TEAM; CONDITIONS APPLY

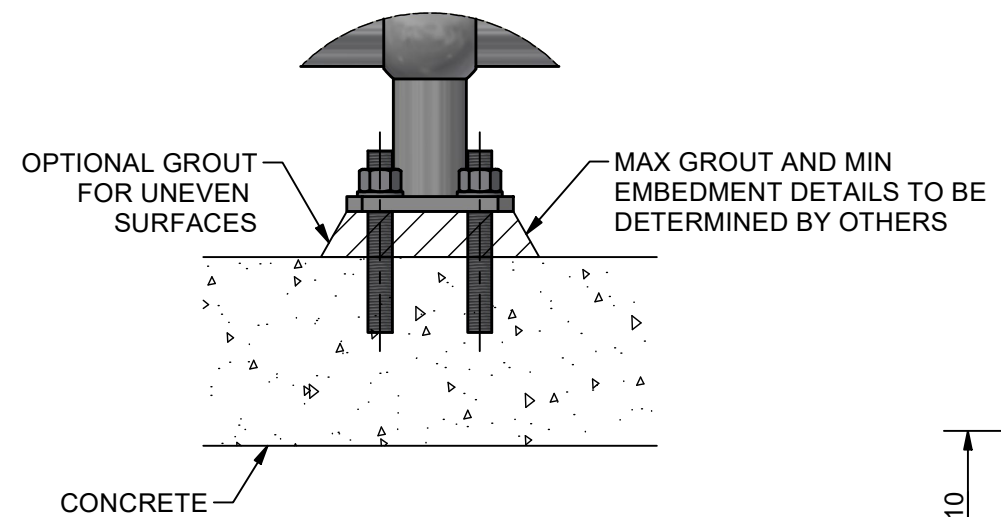

DETAIL 1

FOOTING DETAIL FOR CONCRETE MOUNTING

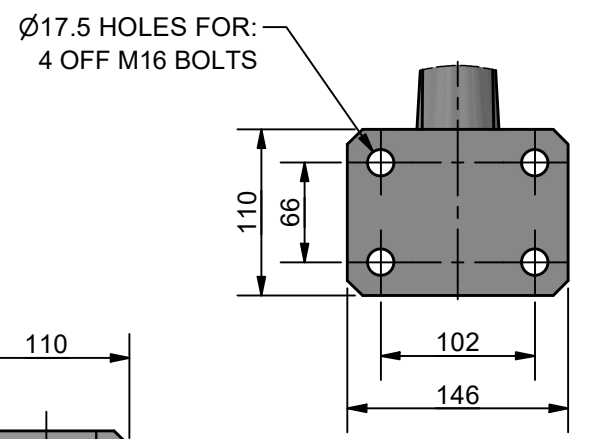

DETAIL 2

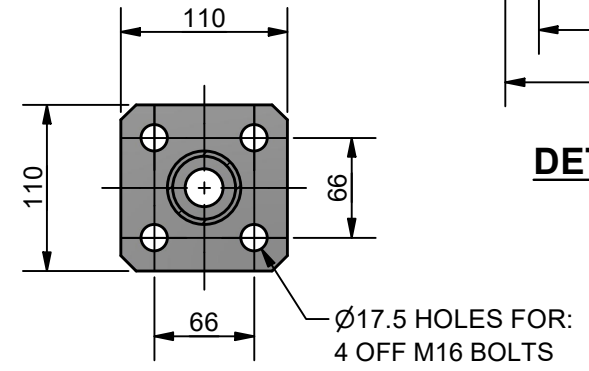

SECTION B-B

NOTES:

- CUSTOMER TO NOMINATE STANCHION TYPE (IN GROUND, PLATFORM OR SIDE).
- CUSTOMER TO NOMINATE KICK PLATE IF REQUIRED (100 x 6mm FLAT).
- PROTECTION TREATMENT AND PAINT SYSTEMS TO BE IN ACCORDANCE WITH CLIENT REQUIREMENTS.
- BARRIER DESIGNED TO MEET RECOMMENDATIONS FOR SHARED PATH BARRIER AS OUTLINED IN AUSTRROADS GUIDE TO ROAD DESIGN PART 6A - PATHS FOR WALKING AND CYCLING.
- ALL POSTS TO BE 40NB (48.3 OD, 3.2 THICK) STEEL PIPE.
- SLIP JOINTS CAN BE REQUESTED BY CLIENT IF HOT WORKS ARE NOT PERMITTED ON SITE.
- BARRIER DESIGNED TO MEET NCC 2016 BCA BARRIER REQUIREMENTS TO PREVENT FALLS.
- REFER "MWBR-EX-005" FOR TYPICAL WELDING DETAILS.
- COLD GALVANISING TREATMENT FOR IN-SITU WELDS, CUT ENDS OR OTHER BARE STEEL TO BE IN ACCORDANCE WITH AS/NZS 4680:2006 CLAUSE 8 REPAIR PROCEDURE.
- PEDESTRIAN BARRIERS ARE NOT INTENDED TO BE USED IN SITUATIONS WHERE MOTOR VEHICLES REQUIRE RESTRAINT.

REV	DESCRIPTION	DATE	DRAWN
2	NOTES REVISED, SPACING TABLE ADDED	25/09/25	AJM
1	DETAIL 2 ADDED, SECTION B-B FIXINGS REVISED	16/06/21	AJM
0	ISSUED FOR PUBLICATION	01/09/20	AJM

 PROJECTION DO NOT SCALE ALL DIMENSIONS IN mm U.N.O.	DRAWN	AJM	CLIENT WEBFORGE LOCKER PRODUCT MONOWILLS VELOCITY FULL BARRIER ASSEMBLY
	DRAWN DATE	01/09/20	
	APPROVED	MT	
	APPROVED DATE	01/09/20	DRAWING NUMBER
	 A valmont COMPANY		SHEET
			MWVL-EX-001
			1 OF 1
			REV
			2

DRAWING DISCLAIMER:
WEBFORGE PROVIDES THE INFORMATION CONTAINED IN THIS DRAWING AS A GUIDE FOR YOUR INFORMATION ONLY. WEBFORGE HAS TAKEN REASONABLE CARE TO ENSURE THE ACCURACY OF THE INFORMATION AT THE TIME OF PRODUCTION. WEBFORGE EXPRESSLY DISCLAIMS ALL LIABILITY WHATSOEVER FOR (INCLUDING ANY DIRECT OR INDIRECT LOSS OR DAMAGE, COSTS OR EXPENSES HOWSOEVER INCURRED BY ANY PERSON) RELIANCE ON THE WHOLE OR ANY PART OF THE INFORMATION CONTAINED IN OR OMITTED FROM THIS DRAWING. WEBFORGE RESERVES THE RIGHT TO MAKE TECHNICAL CHANGES WITHOUT NOTICE.

