

D

C

B

A

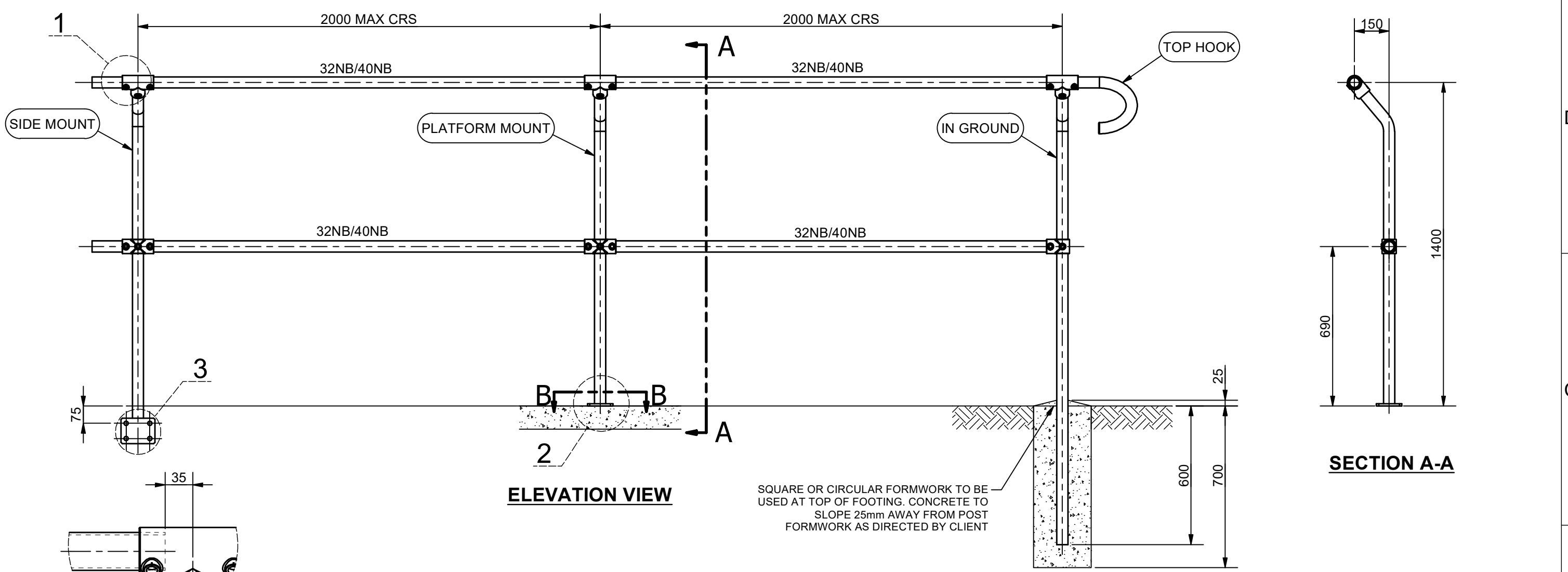

ELEVATION VIEW

SECTION A-A

SQUARE OR CIRCULAR FORMWORK TO BE USED AT TOP OF FOOTING. CONCRETE TO SLOPE 25mm AWAY FROM POST FORMWORK AS DIRECTED BY CLIENT

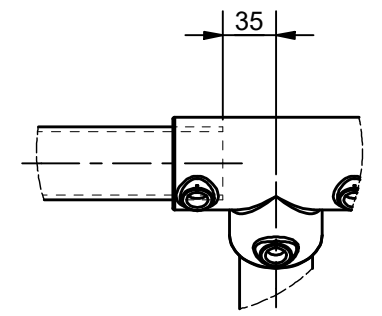

DETAIL 1

Ø18 HOLES FOR:
4/M16x110 CAST IN-SITU GAL BOLTS OR
4/CHEMSET FASTENERS

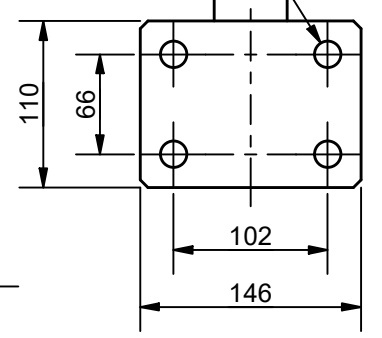

DETAIL 3

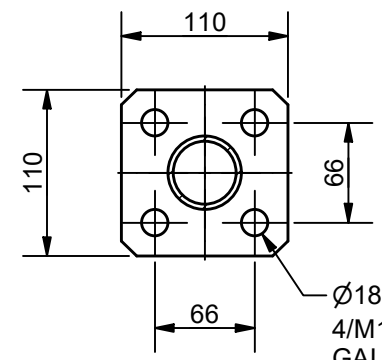

SECTION B-B

Ø18 HOLES FOR:
4/M16x110 CAST IN-SITU GAL BOLTS OR
4/CHEMSET FASTENERS

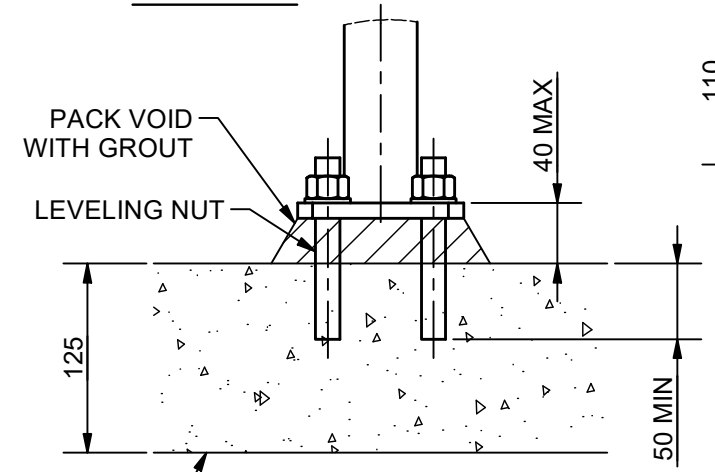

DETAIL 2

CONCRETE SHARED USE PATH

NOTES:

1. CUSTOMER TO NOMINATE PREFERRED FOOTING / FIXING (IN GROUND, PLATFORM & SIDE MOUNT).
2. CUSTOMER TO NOMINATE PREFERRED RAIL SIZE - 32NB STANDARD SYSTEM OR 40NB HEAVY SYSTEM.
3. PROTECTION TREATMENT AND PAINT SYSTEMS TO BE IN ACCORDANCE WITH CLIENT REQUIREMENTS.
4. ALL POSTS TO BE 40NB (48.3 OD, 3.2 THICK) GALVANISED STEEL TUBE.
5. ALL HORIZONTAL RAILS TO BE ROLLED TO MATCH SHAPE OF PATH IF RADIUS IS LESS THAN 14m.
6. BARRIER DESIGNED TO MEET RECOMMENDATIONS FOR SHARED PATH BARRIER AS OUTLINED IN AUSTRROADS GUIDE TO ROAD DESIGN PART 6A - PATHS FOR WALKING AND CYCLING.
7. STANDARD MONOWILLS LINK VELOCITY FULL BARRIER DESIGNED TO MEET BARRIER TYPE C3 AS/NZS 1170.1:2002 (R2016)
8. ALL WELDS TO BE 4MM C.F.W. (CONTINUOUS FILLET WELDS) TO AS/NZS 1554.1.
9. PREFERRED COLD GALVANISING TREATMENT FOR IN-SITU WELDS, CUT ENDS OR OTHER BARE STEEL TO BE IN ACCORDANCE WITH AS/NZS 4680:2006 CLAUSE 8 REPAIR PROCEDURE.
10. ALL CONCRETE TO BE GRADE N25 OR AS CLIENT SPECIFIED.
11. POSTS INSTALLED IN EXISTING BRIDGE/CULVERT CONCRETE TO BE GROUTED INTO Ø90mm HOLE WITH 1:3 CEMENT MORTAR BY VOLUME AFTER THEY HAVE BEEN CAREFULLY ALIGNED.
12. THESE FENCES ARE INTENDED AS A PEDESTRIAN BARRIER AND ARE NOT TO BE USED IN SITUATIONS WHERE MOTOR VEHICLES REQUIRE RESTRAINT.

1	DETAIL 3 ADDED, SECTION B-B FIXINGS REVISED	17/06/21	AJM
0	ISSUED FOR PUBLICATION	27/07/20	AJM
REV	DESCRIPTION	DATE	DRAWN
	DRAWN	AJM	
	DRAWN DATE	19AUG20	
	APPROVED	MT	
	APPROVED DATE	19AUG20	
 DO NOT SCALE		 A valmont COMPANY	
CLIENT WEBFORGE PRODUCT MONOWILLS LINK VELOCITY PARTIAL (2 RAIL) ASSEMBLY		DRAWING NUMBER	SHEET
		LKVL-EX-003	1 OF 1
			REV
			1

DRAWING DISCLAIMER:
WEBFORGE PROVIDES THE INFORMATION CONTAINED IN THIS DRAWING AS A GUIDE FOR YOUR INFORMATION ONLY. WEBFORGE HAS TAKEN REASONABLE CARE TO ENSURE THE ACCURACY OF THE INFORMATION AT THE TIME OF PRODUCTION. WEBFORGE EXPRESSLY DISCLAIMS ALL LIABILITY WHATSOEVER FOR (INCLUDING ANY DIRECT OR INDIRECT LOSS OR DAMAGE, COSTS OR EXPENSES HOWSOEVER INCURRED BY ANY PERSON) RELIANCE ON THE WHOLE OR ANY PART OF THE INFORMATION CONTAINED IN OR OMITTED FROM THIS DRAWING. WEBFORGE RESERVES THE RIGHT TO MAKE TECHNICAL CHANGES WITHOUT NOTICE.

