

**ELEVATION VIEW**

**SECTION A-A**

RECOMMENDED STANCHION SPACING		
STANDARD	LOADING	MAX CRS
AS/NZS 1657	0.35 kN/m	2.0 m *
AS/NZS 1170 (C3)	0.75 kN/m	1.65 m

\*LONGER STANCHION SPACING MAY BE POSSIBLE THROUGH CONSULTATION WITH THE WEBFORGE LOCKER TECHNICAL TEAM; CONDITIONS APPLY

**NOTES:**

- CUSTOMER TO NOMINATE STANCHION TYPE (IN GROUND, PLATFORM OR SIDE).
- ALL POSTS TO BE 40NB (48.3 OD, 3.2 THICK) GALVANISED STEEL PIPE.
- ALL HORIZONTAL RAILS TO BE ROLLED TO MATCH SHAPE OF PATH IF RADIUS IS LESS THAN 14m.
- BARRIER DESIGNED TO MEET FUNCTIONAL REQUIREMENTS OF AS/NZS 1428.1:2009 - DESIGN FOR ACCESS AND MOBILITY.
- AS PER AS/NZS 1428.1:2009 HANDRAIL TO BE UNBROKEN & CONTINUOUS WITHOUT HAND OBSTRUCTION AND TERMINATION MUST EXTEND 300MM PARALLEL TO SURFACE BELOW.
- REFER "MWBR-EX-005" FOR TYPICAL WELDING DETAILS.
- COLD GALVANISING TREATMENT FOR IN-SITU WELDS, CUT ENDS OR OTHER BARE STEEL TO BE IN ACCORDANCE WITH AS/NZS 4680:2006 CLAUSE 8 REPAIR PROCEDURE.
- PEDESTRIAN BARRIERS ARE NOT INTENDED TO BE USED IN SITUATIONS WHERE MOTOR VEHICLES REQUIRE RESTRAINT.
- ANGLE MOUNT STANCHIONS WILL NOT BE SUPPLIED IN ANGLE SCENARIOS OF 5 DEGREES OR LESS.
- WEBFORGE LOCKER HANDRAIL SYSTEMS DO NOT COMPLY WITH AS1428.2

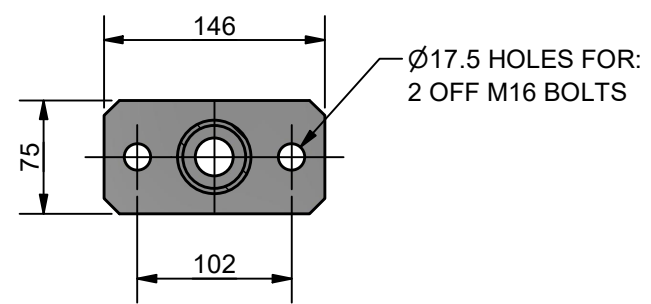

**SECTION B-B**  
TYPICAL BASE PLATE DETAIL FOR PLATFORM AND SIDE STANCHIONS

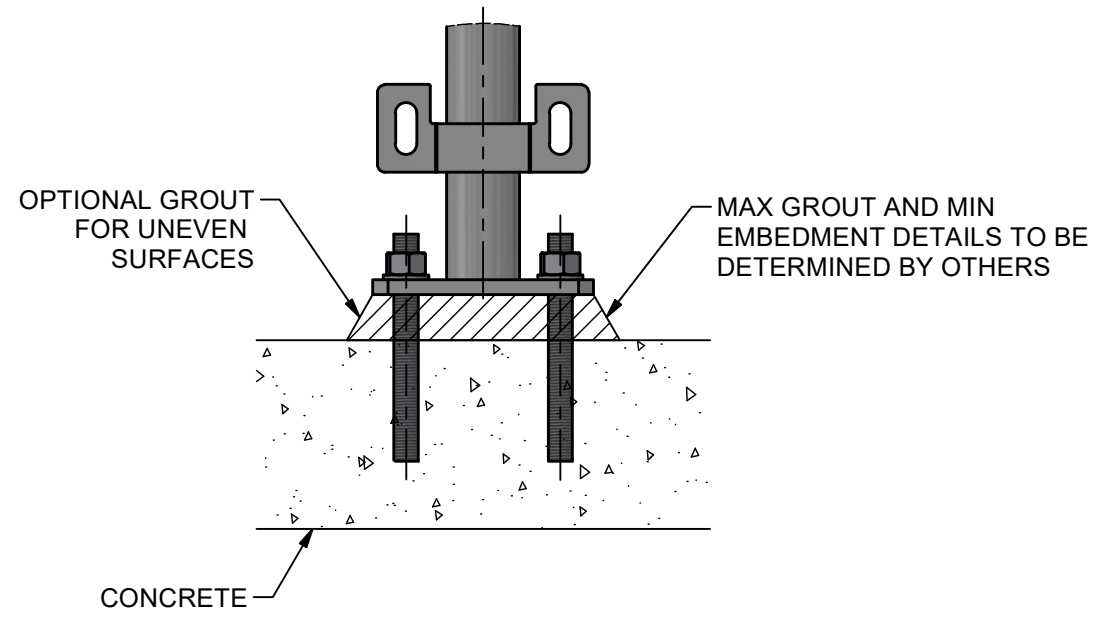

**DETAIL 1**  
FOOTING DETAIL FOR CONCRETE MOUNTING  
KERB RAIL NOT SHOWN FOR CLARITY

REV	DESCRIPTION	DATE	DRAWN
4	HANDRAIL FITTING CHANGED, NOTES REVISED	24/09/25	AJM
3	KERB RAIL HEIGHT REVISED	20/03/23	AJM
2	DISABILITY RAIL HEIGHT CHANGED TO 900 FROM 1000	08/09/22	AJM

 PROJECTION DO NOT SCALE ALL DIMENSIONS IN mm U.N.O.	DRAWN	MDG	CLIENT WEBFORGE LOCKER PRODUCT <b>MONOWILLS LINK</b> DISABILITY 1 RAIL C/W KERB RAIL ASSEMBLY
	DRAWN DATE	14/10/20	
	APPROVED	MT	
	APPROVED DATE	14/10/20	
	 A valmont COMPANY		DRAWING NUMBER LKDS-EX-004
			SHEET 1 OF 1
			REV 4

**DRAWING DISCLAIMER:**  
WEBFORGE PROVIDES THE INFORMATION CONTAINED IN THIS DRAWING AS A GUIDE FOR YOUR INFORMATION ONLY. WEBFORGE HAS TAKEN REASONABLE CARE TO ENSURE THE ACCURACY OF THE INFORMATION AT THE TIME OF PRODUCTION. WEBFORGE EXPRESSLY DISCLAIMS ALL LIABILITY WHATSOEVER FOR (INCLUDING ANY DIRECT OR INDIRECT LOSS OR DAMAGE, COSTS OR EXPENSES HOWSOEVER INCURRED BY ANY PERSON) RELIANCE ON THE WHOLE OR ANY PART OF THE INFORMATION CONTAINED IN OR OMITTED FROM THIS DRAWING. WEBFORGE RESERVES THE RIGHT TO MAKE TECHNICAL CHANGES WITHOUT NOTICE.

