

ELEVATION VIEW

SECTION A-A

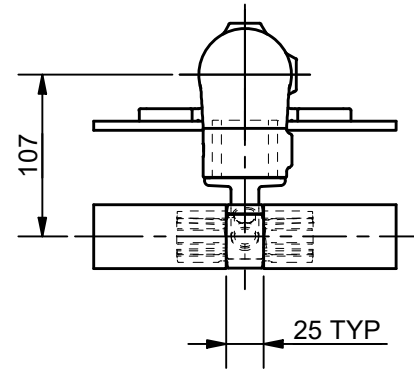

SECTION B-B

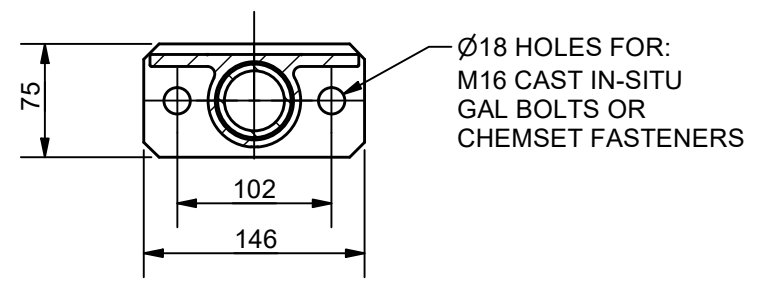

SECTION C-C
(TYPICAL BASE PLATE DETAIL FOR PLATFORM AND SIDE STANCHIONS)
(KICK PLATE NOT SHOWN FOR CLARITY)

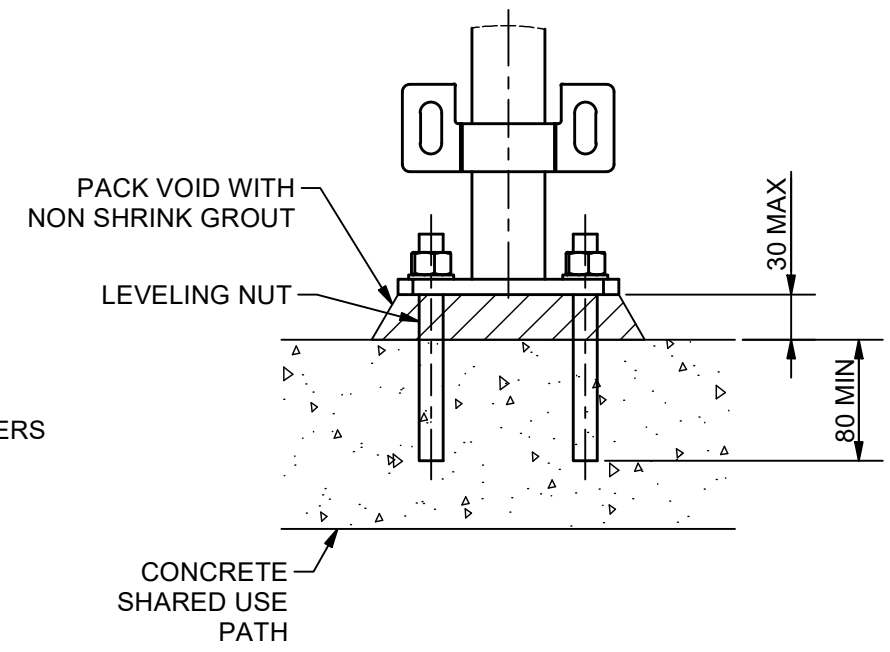

DETAIL 1
(KERB RAIL NOT SHOWN FOR CLARITY)

NOTES:

- CUSTOMER TO NOMINATE PREFERRED FOOTING / FIXING (IN GROUND, PLATFORM & SIDE MOUNT).
- ALL POSTS TO BE 40NB (48.3 OD, 3.2 THICK) GALVANISED STEEL TUBE.
- ALL HORIZONTAL RAILS TO BE ROLLED TO MATCH SHAPE OF PATH IF RADIUS IS LESS THAN 14m.
- BARRIER DESIGNED TO MEET FUNCTIONAL REQUIREMENTS OF AS/NZS 1428.1:2009 - DESIGN FOR ACCESS AND MOBILITY
- STANDARD MONOWILLS LINK DISABILITY 1 RAIL DESIGNED TO MEET BARRIER TYPE C3 AS/NZS 1170.1:2002 (R2016)
- AS PER AS/NZS 1428.1:2009 HANDRAIL TO BE UNBROKEN & CONTINUOUS WITHOUT HAND OBSTRUCTION AND TERMINATION MUST EXTEND 300MM PARALLEL TO SURFACE BELOW
- PREFERRED COLD GALVANISING TREATMENT FOR IN-SITU WELDS, CUT ENDS OR OTHER BARE STEEL TO BE IN ACCORDANCE WITH AS/NZS 4680:2006 CLAUSE 8 REPAIR PROCEDURE.
- PROTECTION TREATMENT AND PAINT SYSTEMS TO BE IN ACCORDANCE WITH CLIENT REQUIREMENTS.
- ALL CONCRETE TO BE GRADE N25 OR AS CLIENT SPECIFIED.
- POSTS INSTALLED IN EXISTING CONCRETE TO BE GROUTED INTO Ø90mm HOLE WITH 1:3 CEMENT MORTAR BY VOLUME AFTER THEY HAVE BEEN CAREFULLY ALIGNED.
- THESE FENCES ARE INTENDED AS A PEDESTRIAN BARRIER AND ARE NOT TO BE USED IN SITUATIONS WHERE MOTOR VEHICLES REQUIRE RESTRAINT.
- WEBFORGE LOCKER HANDRAIL SYSTEMS DO NOT COMPLY WITH AS1428.2
- ANGLE MOUNT STANCHIONS WILL NOT BE SUPPLIED IN ANGLE SCENARIOS OF 5 DEGREES OR LESS.

REV	DESCRIPTION	DATE	DRAWN
3	KERB RAIL HEIGHT REVISED	20/03/2023	AJM
2	DISABILITY RAIL HEIGHT CHANGED TO 900 FROM 1000	8/09/2022	AJM
1	HR TERMINATION AND SECTION LETTERS REVISED	30/07/21	AJM
0	ISSUED FOR PUBLICATION	05/02/21	MDG

PROJECTION DO NOT SCALE ALL DIMENSIONS IN mm U.N.O.	DRAWN: MDG DRAWN DATE: 14OCT20 APPROVED: MT APPROVED DATE: 14OCT20	CLIENT: WEBFORGE PRODUCT: MONOWILLS LINK DISABILITY 1 RAIL C/W KICK PLATE ASSEMBLY
		DRAWING NUMBER: LKDS-EX-004 SHEET: 1 OF 1 REV: 3
	A valmont COMPANY	

DRAWING DISCLAIMER:
WEBFORGE PROVIDES THE INFORMATION CONTAINED IN THIS DRAWING AS A GUIDE FOR YOUR INFORMATION ONLY. WEBFORGE HAS TAKEN REASONABLE CARE TO ENSURE THE ACCURACY OF THE INFORMATION AT THE TIME OF PRODUCTION. WEBFORGE EXPRESSLY DISCLAIMS ALL LIABILITY WHATSOEVER FOR (INCLUDING ANY DIRECT OR INDIRECT LOSS OR DAMAGE, COSTS OR EXPENSES HOWSOEVER INCURRED BY ANY PERSON) RELIANCE ON THE WHOLE OR ANY PART OF THE INFORMATION CONTAINED IN OR OMITTED FROM THIS DRAWING. WEBFORGE RESERVES THE RIGHT TO MAKE TECHNICAL CHANGES WITHOUT NOTICE.

