

ELEVATION VIEW

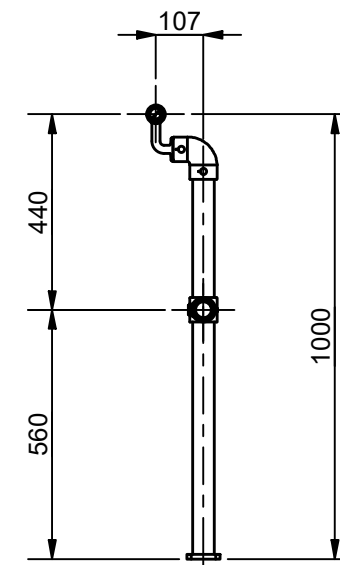

SECTION A-A

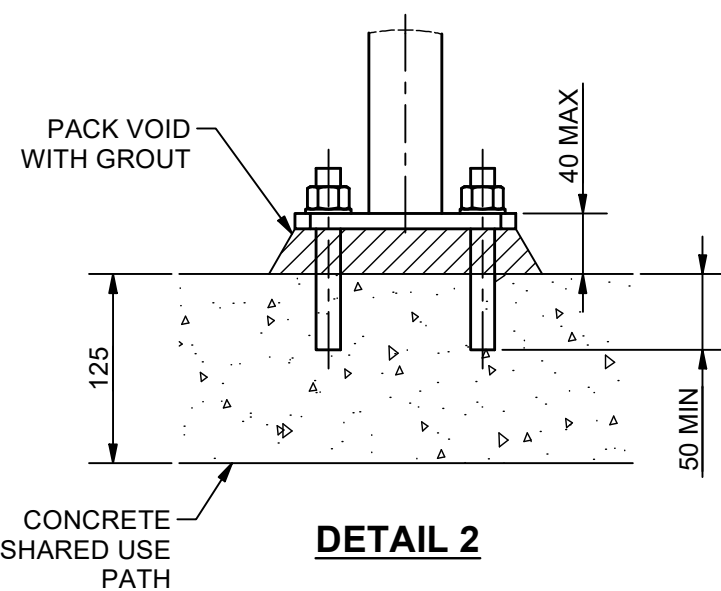

DETAIL 2

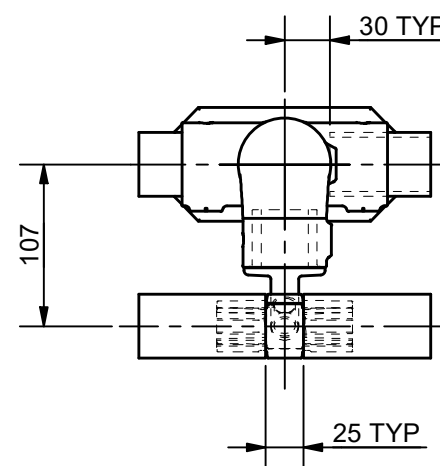

SECTION B-B

NOTES:

1. CUSTOMER TO NOMINATE PREFERRED FOOTING / FIXING (IN GROUND, PLATFORM & SIDE MOUNT).
2. PROTECTION TREATMENT AND PAINT SYSTEMS TO BE IN ACCORDANCE WITH CLIENT REQUIREMENTS.
3. ALL POSTS TO BE 40NB (48.3 OD, 3.2 THICK) GALVANISED STEEL TUBE.
4. ALL HORIZONTAL RAILS TO BE ROLLED TO MATCH SHAPE OF PATH IF RADIUS IS LESS THAN 14m.
5. STANDARD MONOWILLS LINK DESIGNED TO MEET BARRIER TYPE C3 AS/NZS 1170.1:2002 (R2016)
6. AS PER AS/NZS 1428.1:2009 HANDRAIL TO BE UNBROKEN & CONTINUOUS WITHOUT HAND OBSTRUCTION AND TERMINATION MUST EXTEND 300MM PARALLEL TO SURFACE BELOW
7. PREFERRED COLD GALVANISING TREATMENT FOR IN-SITU WELDS, CUT ENDS OR OTHER BARE STEEL TO BE IN ACCORDANCE WITH AS/NZS 4680:2006 CLAUSE 8 REPAIR PROCEDURE.
8. ALL CONCRETE TO BE GRADE N25 OR AS CLIENT SPECIFIED.
9. POSTS INSTALLED IN EXISTING BRIDGE/CULVERT CONCRETE TO BE GROUTED INTO Ø90mm HOLE WITH 1:3 CEMENT MORTAR BY VOLUME AFTER THEY HAVE BEEN CAREFULLY ALIGNED.
10. THESE FENCES ARE INTENDED AS A PEDESTRIAN BARRIER AND ARE NOT TO BE USED IN SITUATIONS WHERE MOTOR VEHICLES REQUIRE RESTRAINT.

0	ISSUED FOR PUBLICATION	31/08/21	AJM
REV	DESCRIPTION	DATE	DRAWN
	DRAWN	AJM	
	DRAWN DATE	31/08/21	
	APPROVED	MT	
	APPROVED DATE	31/08/21	
		CLIENT WEBFORGE PRODUCT MONOWILLS LINK BARRIER PUBLIC ACCESS (2 RAIL) ASSEMBLY	
DRAWING NUMBER		SHEET	REV
LKBR-EX-002		1 OF 1	0

DRAWING DISCLAIMER:
 WEBFORGE PROVIDES THE INFORMATION CONTAINED IN THIS DRAWING AS A GUIDE FOR YOUR INFORMATION ONLY. WEBFORGE HAS TAKEN REASONABLE CARE TO ENSURE THE ACCURACY OF THE INFORMATION AT THE TIME OF PRODUCTION. WEBFORGE EXPRESSLY DISCLAIMS ALL LIABILITY WHATSOEVER FOR (INCLUDING ANY DIRECT OR INDIRECT LOSS OR DAMAGE, COSTS OR EXPENSES HOWSOEVER INCURRED BY ANY PERSON) RELIANCE ON THE WHOLE OR ANY PART OF THE INFORMATION CONTAINED IN OR OMITTED FROM THIS DRAWING. WEBFORGE RESERVES THE RIGHT TO MAKE TECHNICAL CHANGES WITHOUT NOTICE.



ALL DIMENSIONS IN mm U.N.O.

A valmont COMPANY