

ELEVATION VIEW

SECTION A-A

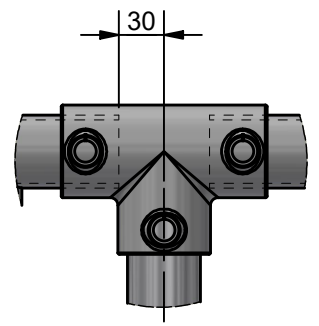

DETAIL 1

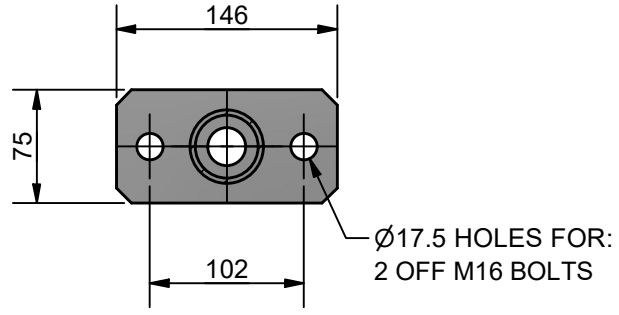

SECTION B-B
TYPICAL BASE PLATE DETAIL
FOR PLATFORM AND SIDE STANCHIONS

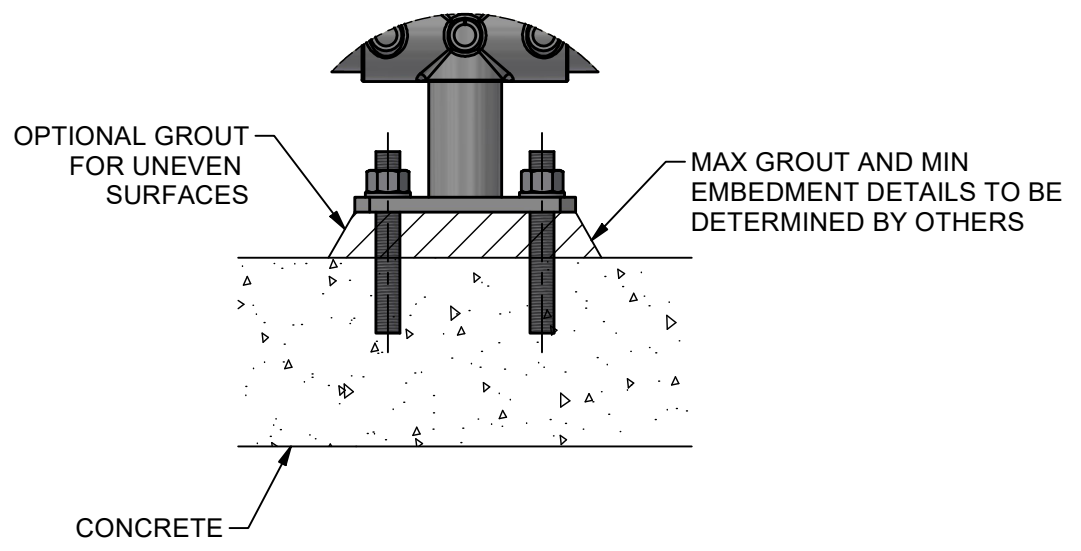

DETAIL 2
FOOTING DETAIL FOR CONCRETE MOUNTING

RECOMMENDED STANCHION SPACING		
STANDARD	LOADING	MAX CRS
AS/NZS 1657	0.35 kN/m	1.8 m *
AS/NZS 1170 (C3)	0.75 kN/m	1.65 m

*LONGER STANCHION SPACING MAY BE POSSIBLE THROUGH CONSULTATION WITH THE WEBFORGE LOCKER TECHNICAL TEAM; CONDITIONS APPLY

- NOTES:**
- CUSTOMER TO NOMINATE STANCHION TYPE (IN GROUND, PLATFORM OR SIDE).
 - CUSTOMER TO NOMINATE RAIL SIZE - 32NB STANDARD SYSTEM OR 40NB HEAVY SYSTEM.
 - CUSTOMER TO NOMINATE KICK PLATE IF REQUIRED (100 x 6mm FLAT).
 - ALL POSTS TO BE 40NB (48.3 OD, 3.2 THICK) GALVANISED STEEL PIPE.
 - ALL HORIZONTAL RAILS TO BE ROLLED TO MATCH SHAPE OF PATH IF RADIUS IS LESS THAN 14m.
 - BARRIER DESIGNED TO MEET NCC 2016 BCA BARRIER REQUIREMENTS TO PREVENT FALLS
 - REFER "MWBR-EX-005" FOR TYPICAL WELDING DETAILS.
 - COLD GALVANISING TREATMENT FOR IN-SITU WELDS, CUT ENDS OR OTHER BARE STEEL TO BE IN ACCORDANCE WITH AS/NZS 4680:2006 CLAUSE 8 REPAIR PROCEDURE.
 - PEDESTRIAN BARRIERS ARE NOT INTENDED TO BE USED IN SITUATIONS WHERE MOTOR VEHICLES REQUIRE RESTRAINT.

REV	DESCRIPTION	DATE	DRAWN
3	NOTES REVISED, SPACING TABLE ADDED	25/09/25	AJM
2	DIMENSIONS ADDED	21/04/21	AJM
1	FIXING SIZE CHANGED TO M16	09/04/21	AJM
0	ISSUED FOR PUBLICATION	29/11/20	AJM

 PROJECTION DO NOT SCALE ALL DIMENSIONS IN mm U.N.O.	DRAWN: AJM DRAWN DATE: 29/11/20 APPROVED: MT APPROVED DATE: 29/11/20	CLIENT: WEBFORGE LOCKER PRODUCT: MONOWILLS LINK BALUSTRADE FULL BARRIER ASSEMBLY DRAWING NUMBER: LKBA-EX-001	SHEET: 1 OF 1 REV: 3
	WEBFORGE LOCKER A valmont COMPANY		

DRAWING DISCLAIMER:
WEBFORGE PROVIDES THE INFORMATION CONTAINED IN THIS DRAWING AS A GUIDE FOR YOUR INFORMATION ONLY. WEBFORGE HAS TAKEN REASONABLE CARE TO ENSURE THE ACCURACY OF THE INFORMATION AT THE TIME OF PRODUCTION. WEBFORGE EXPRESSLY DISCLAIMS ALL LIABILITY WHATSOEVER FOR (INCLUDING ANY DIRECT OR INDIRECT LOSS OR DAMAGE, COSTS OR EXPENSES HOWSOEVER INCURRED BY ANY PERSON) RELIANCE ON THE WHOLE OR ANY PART OF THE INFORMATION CONTAINED IN OR OMITTED FROM THIS DRAWING. WEBFORGE RESERVES THE RIGHT TO MAKE TECHNICAL CHANGES WITHOUT NOTICE.

