

ELEVATION VIEW

SECTION A-A

SQUARE OR CIRCULAR FORMWORK TO BE USED AT TOP OF FOOTING. CONCRETE TO SLOPE 25mm AWAY FROM POST FORMWORK AS DIRECTED BY CLIENT

NOTES:

1. CUSTOMER TO NOMINATE PREFERRED FOOTING / FIXING (IN GROUND, PLATFORM & SIDE MOUNT).
2. CUSTOMER TO NOMINATE PREFERRED RAIL SIZE - 32NB STANDARD SYSTEM OR 40NB HEAVY SYSTEM.
3. CUSTOMER TO NOMINATE KICK PLATE IF REQUIRED (100MM X 6MM)
4. PROTECTION TREATMENT AND PAINT SYSTEMS TO BE IN ACCORDANCE WITH CLIENT REQUIREMENTS.
5. ALL POSTS TO BE 40NB (48.3 OD, 3.2 THICK) GALVANISED STEEL TUBE.
6. ALL HORIZONTAL RAILS TO BE ROLLED TO MATCH SHAPE OF PATH IF RADIUS IS LESS THAN 14m.
7. STANDARD MONOWILLS LINK BALUSTRADE FULL BARRIER DESIGNED TO MEET BARRIER TYPE C3 AS/NZS 1170.1:2002 (R2016)
8. BARRIER DESIGNED TO MEET NCC 2016 BCA BARRIER REQUIREMENTS TO PREVENT FALLS
9. ALL WELDS TO BE 4MM C.F.W. (CONTINUOUS FILLET WELDS) TO AS/NZS 1554.1.
10. PREFERRED COLD GALVANISING TREATMENT FOR IN-SITU WELDS, CUT ENDS OR OTHER BARE STEEL TO BE IN ACCORDANCE WITH AS/NZS 4680:2006 CLAUSE 8 REPAIR PROCEDURE.
11. ALL CONCRETE TO BE GRADE N25 OR AS CLIENT SPECIFIED.
12. POSTS INSTALLED IN EXISTING BRIDGE/CULVERT CONCRETE TO BE GROUTED INTO Ø90mm HOLE WITH 1:3 CEMENT MORTAR BY VOLUME AFTER THEY HAVE BEEN CAREFULLY ALIGNED.
13. THESE FENCES ARE INTENDED AS A PEDESTRIAN BARRIER AND ARE NOT TO BE USED IN SITUATIONS WHERE MOTOR VEHICLES REQUIRE RESTRAINT.

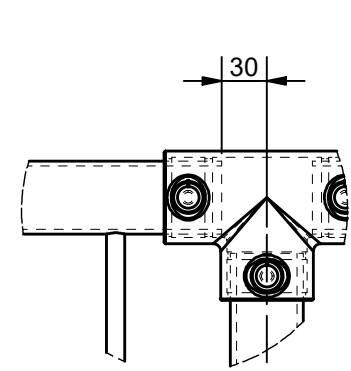

DETAIL 1

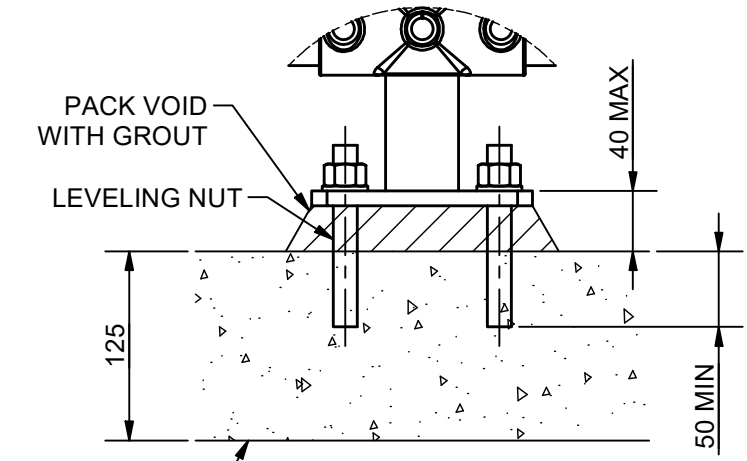

DETAIL 2

CONCRETE SHARED USE PATH

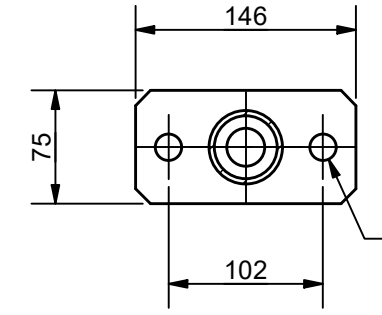

SECTION B-B
(TYPICAL BASE PLATE DETAIL FOR PLATFORM AND SIDE STANCHIONS)

Ø18 HOLES FOR:
2/M16x110 CAST IN-SITU GAL BOLTS OR
2/CHEMSET FASTENERS

REV	DESCRIPTION	DATE	DRAWN
2	DIMENSIONS ADDED	21/04/21	AJM
1	FIXING SIZE CHANGED TO M16	09/04/21	AJM
0	ISSUED FOR PUBLICATION	29/11/20	AJM

 PROJECTION DO NOT SCALE ALL DIMENSIONS IN mm U.N.O.	DRAWN	AJM	CLIENT WEBFORGE PRODUCT MONOWILLS LINK BALUSTRADE FULL BARRIER ASSEMBLY
	DRAWN DATE	29NOV20	
	APPROVED	MT	
	APPROVED DATE	29NOV20	
 A valmont COMPANY		DRAWING NUMBER	SHEET
		LKBA-EX-001	1 OF 1
			REV
			2

DRAWING DISCLAIMER:
WEBFORGE PROVIDES THE INFORMATION CONTAINED IN THIS DRAWING AS A GUIDE FOR YOUR INFORMATION ONLY. WEBFORGE HAS TAKEN REASONABLE CARE TO ENSURE THE ACCURACY OF THE INFORMATION AT THE TIME OF PRODUCTION. WEBFORGE EXPRESSLY DISCLAIMS ALL LIABILITY WHATSOEVER FOR (INCLUDING ANY DIRECT OR INDIRECT LOSS OR DAMAGE, COSTS OR EXPENSES HOWSOEVER INCURRED BY ANY PERSON) RELIANCE ON THE WHOLE OR ANY PART OF THE INFORMATION CONTAINED IN OR OMITTED FROM THIS DRAWING. WEBFORGE RESERVES THE RIGHT TO MAKE TECHNICAL CHANGES WITHOUT NOTICE.

