

6

5

4

3

2

1

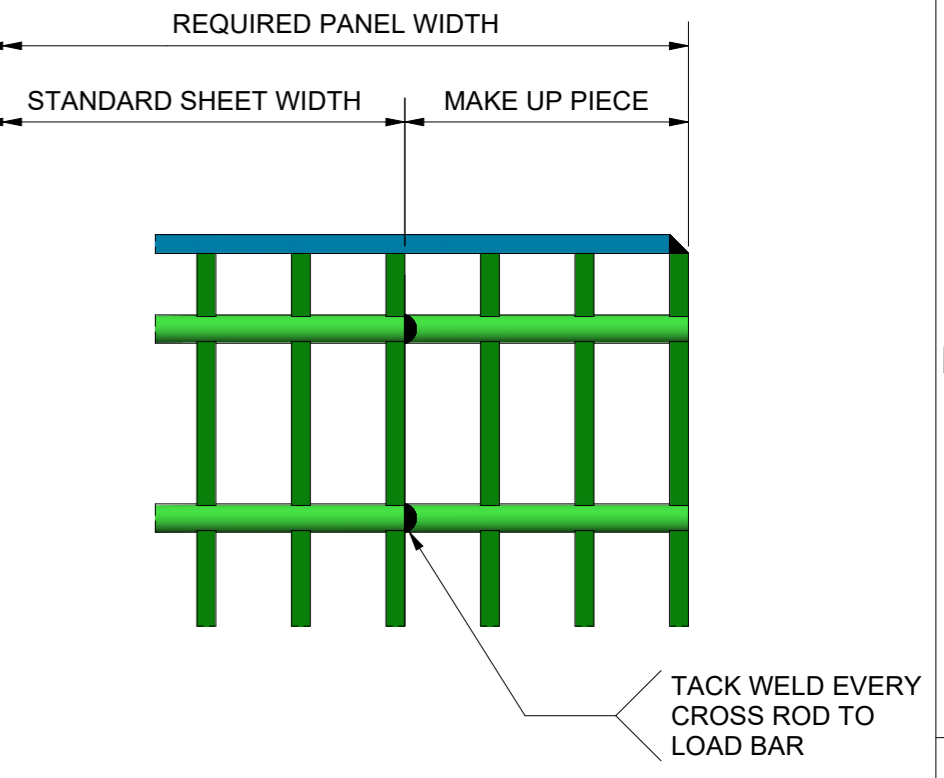
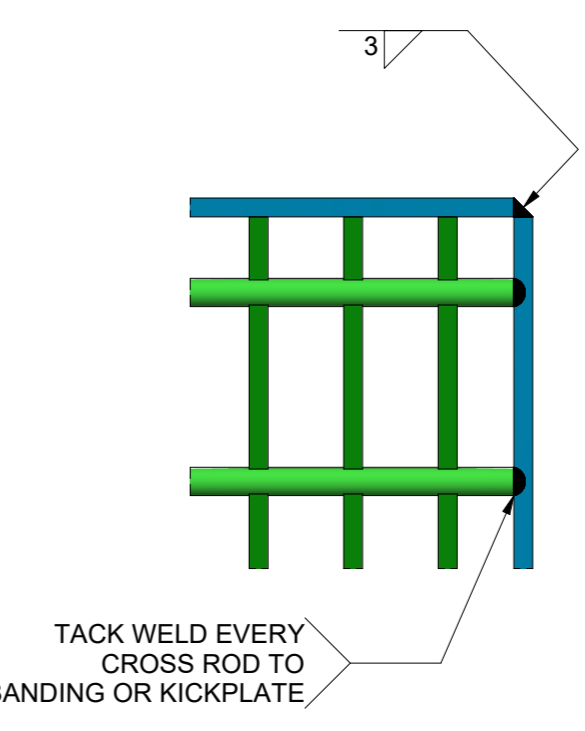
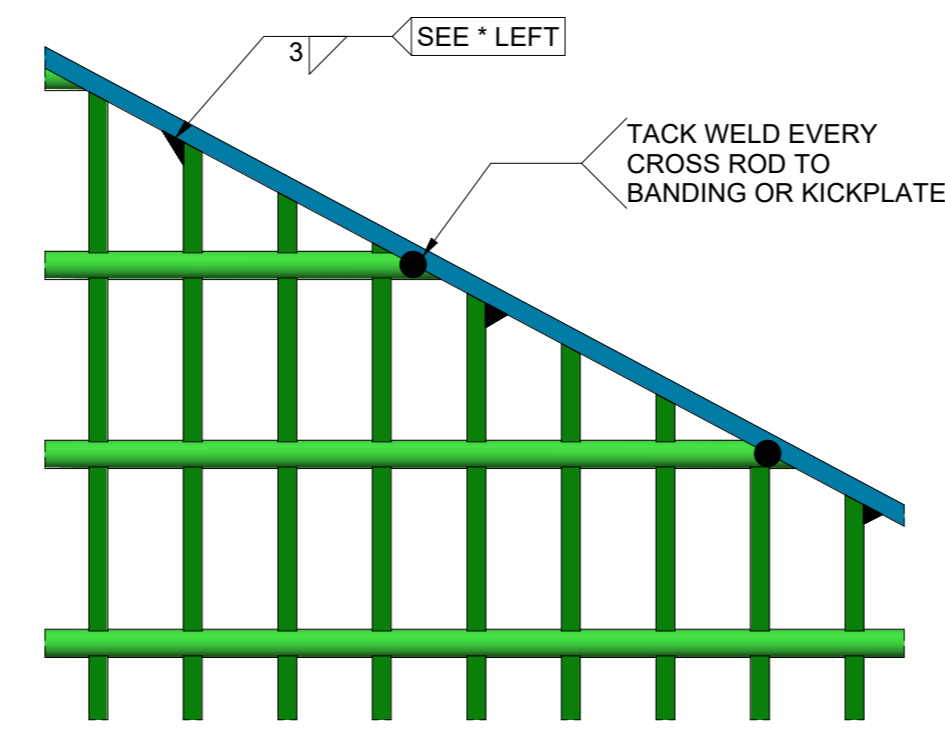
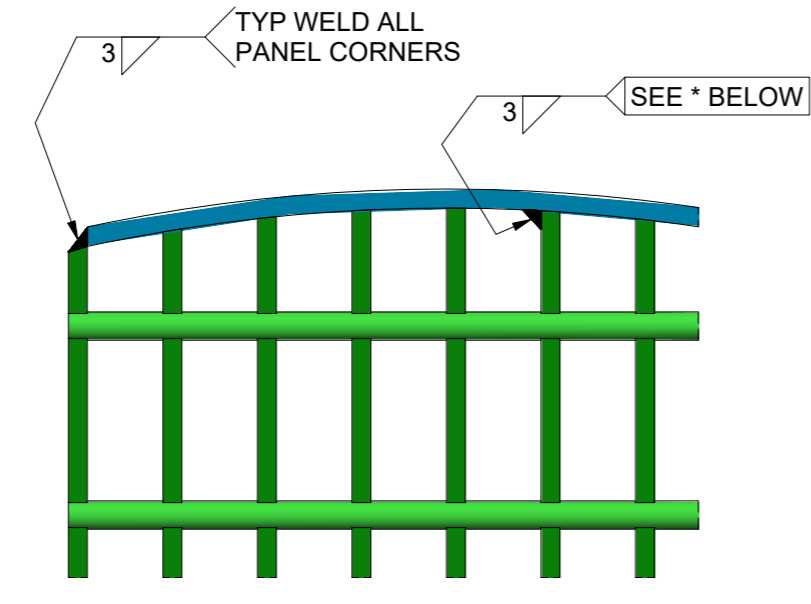
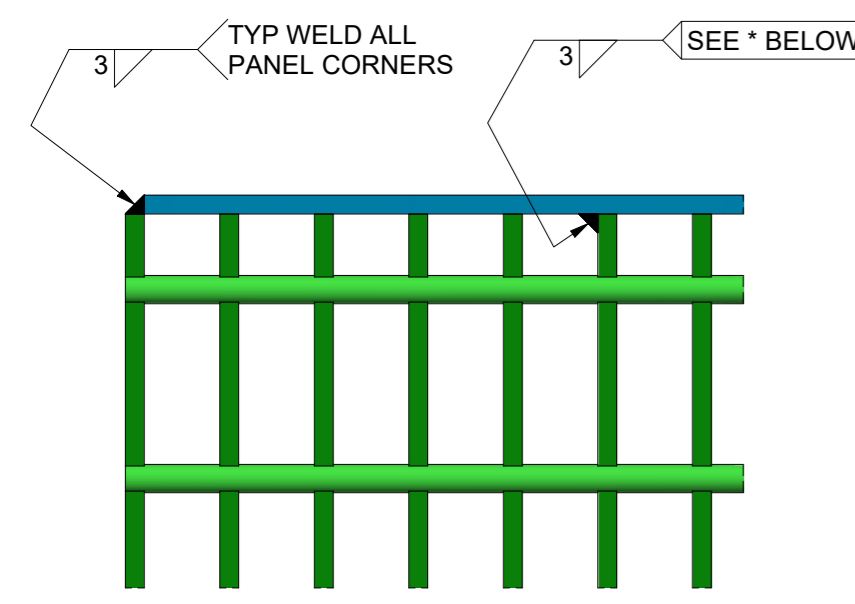

*** BANDING BAR WELD 20mm OR HALF OF DEPTH (WHICH EVER IS GREATER) KICK PLATE WELD FULL DEPTH**
 - WELD ONE SIDE OF EVERY 5th LOAD BAR FOR A & B GRATING
 - WELD ONE SIDE OF EVERY 4th LOAD BAR FOR C & D GRATING
 - WELD ONE SIDE OF EVERY 3th LOAD BAR FOR E & F GRATING
 - WELD ONE SIDE OF EVERY LOAD BAR FOR DRAINAGE GRATING

END BANDING

SPLAY BANDING

SIDE BANDING

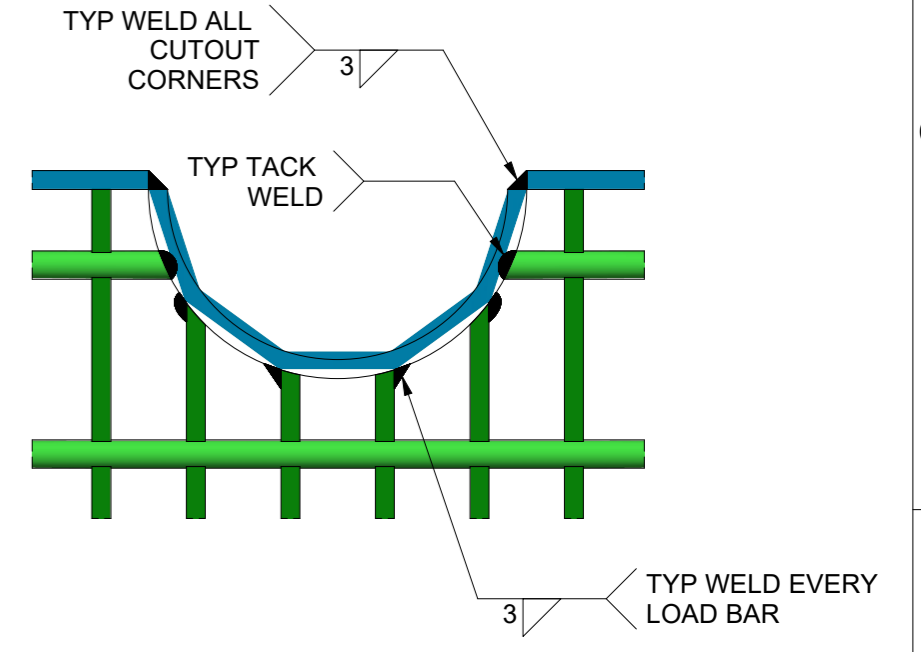
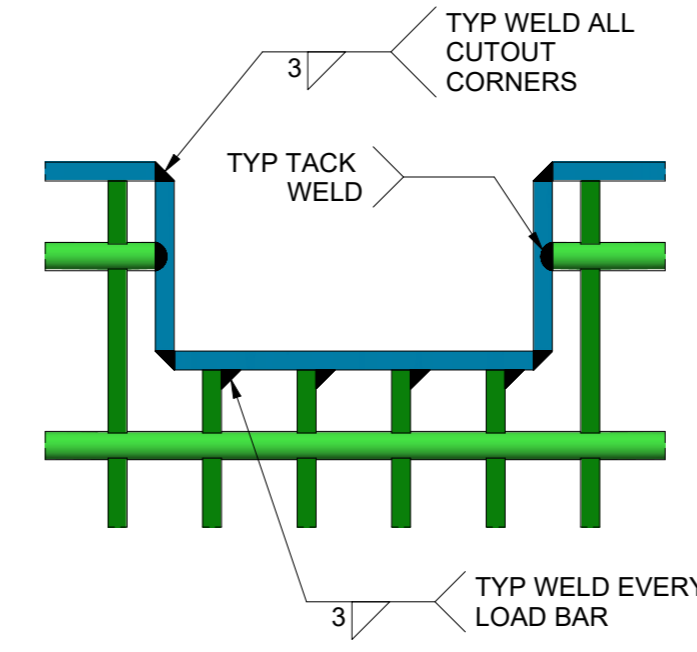
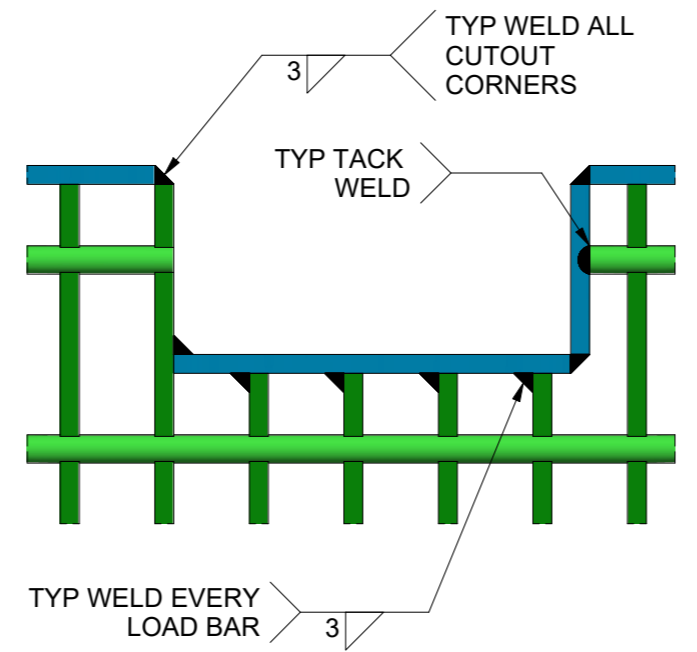
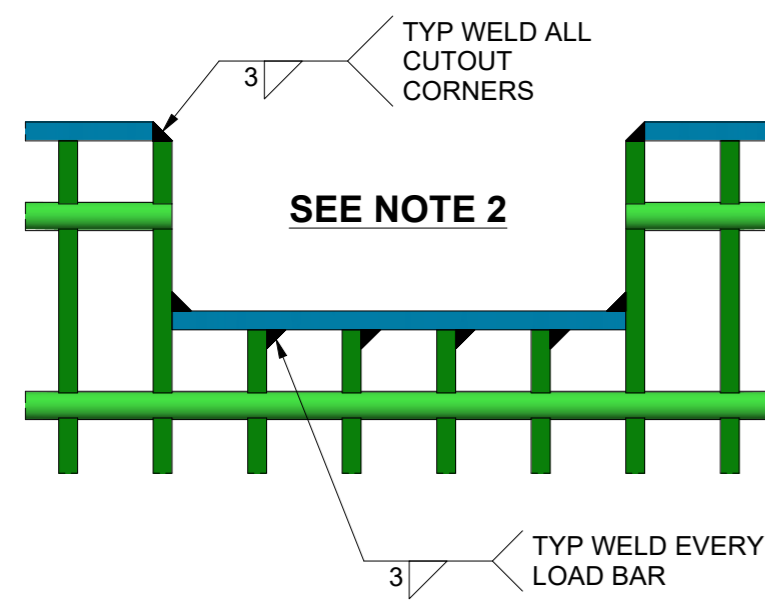

SIDE JOINING

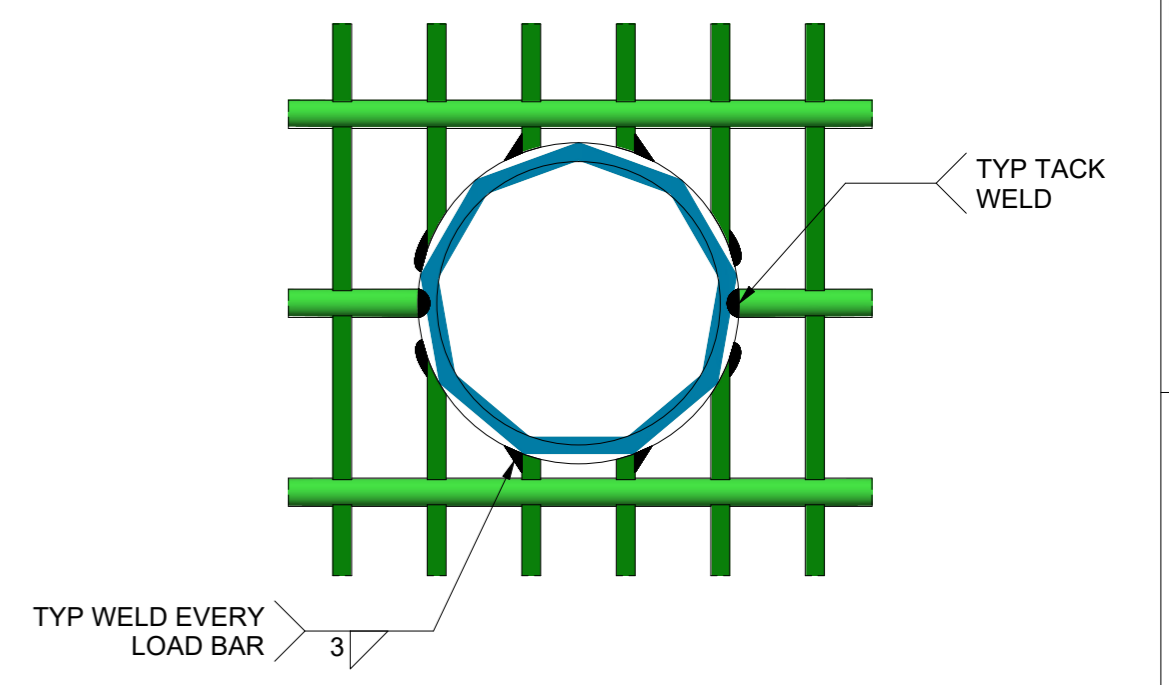
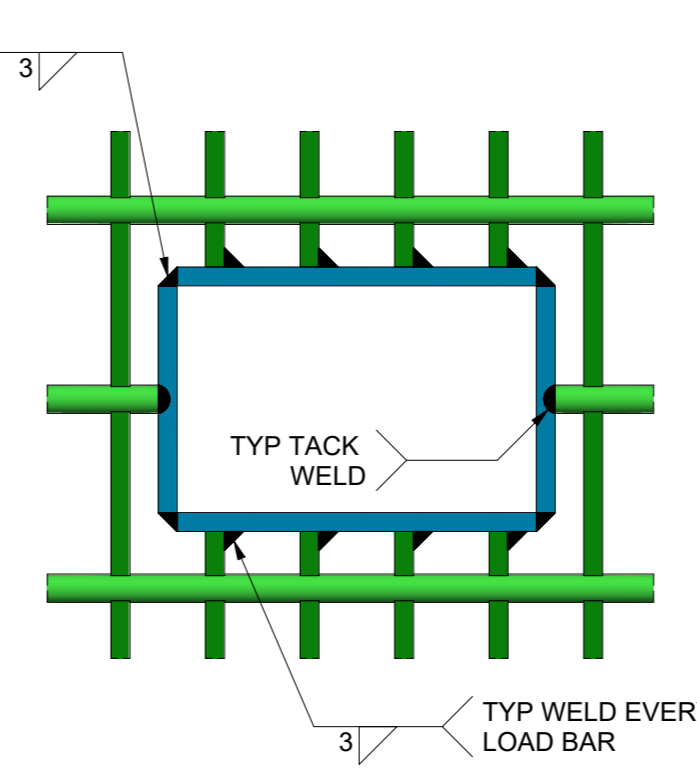
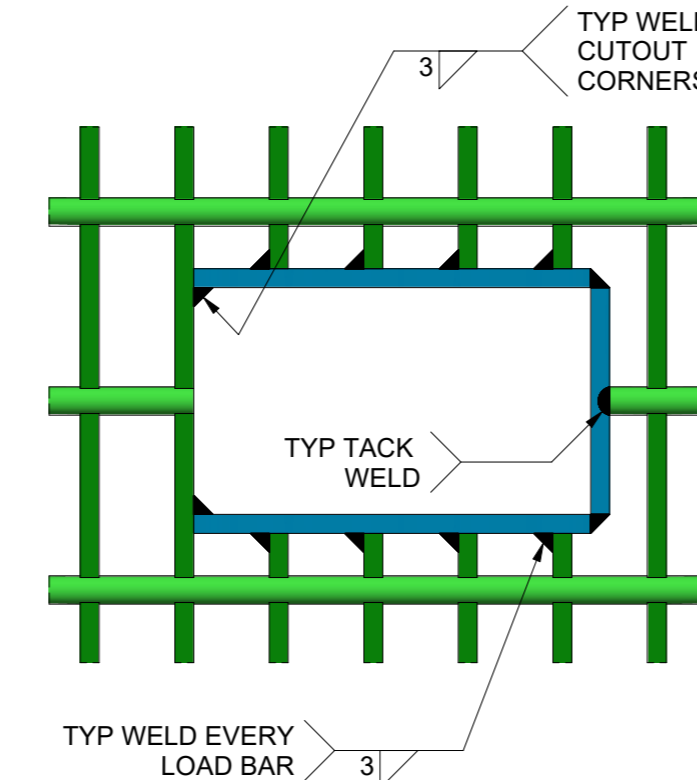
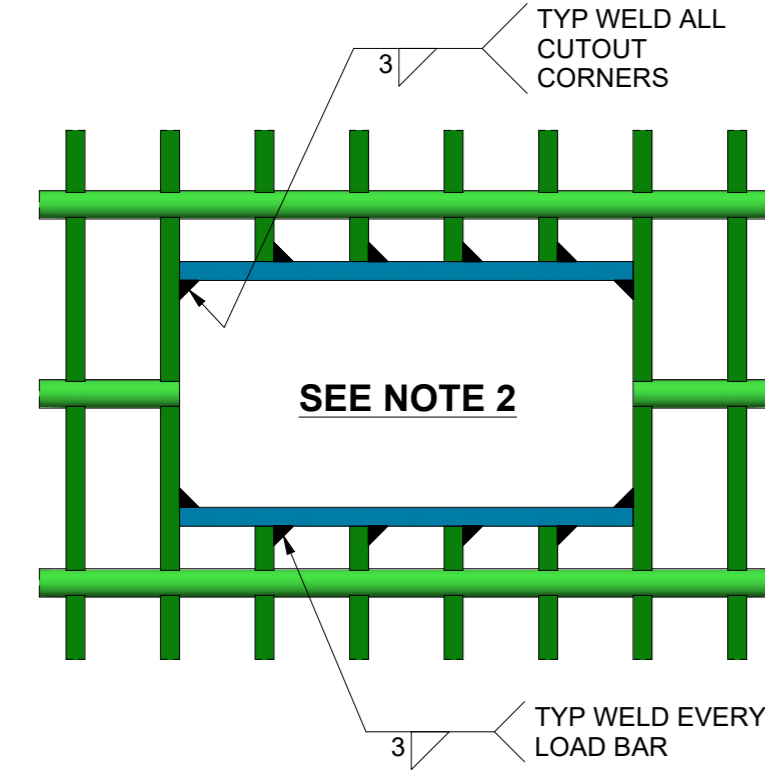

GRATING CUT-OUTS



GRATING PENETRATIONS

-  **BANDING OR KICKPLATE**
-  **TWIST RODS**
-  **LOAD BARS**

NOTES

1. ALL WELDS FULL DEPTH U.N.O
2. ALL PENETRATIONS AND CUT-OUTS WILL BE ENLARGED TO THE NEAREST LOAD BAR WHEN THEY FALL WITHIN 40MM OF THAT LOAD BAR
3. NO WELDS TO PROTRUDE BELOW U/S OF GRATING
4. ALL BANDING BARS TO BE 5mm THICK, ALL KICK PLATE TO BE 6mm THICK
5. BANDING WILL BE IN PLAIN MATERIAL UNLESS SPECIFIED OTHERWISE
6. 3mm WELD IS THE MINIMUM SIZE REQUIRED
7. EDGE BARS BETWEEN SIDE CUT AND JOINED SERRATED PANELS MUST BE SERRATED

DRAWING DISCLAIMER:
 WEBFORGE PROVIDES THE INFORMATION CONTAINED IN THIS DRAWING AS A GUIDE FOR YOUR INFORMATION ONLY. WEBFORGE HAS TAKEN REASONABLE CARE TO ENSURE THE ACCURACY OF THE INFORMATION AT THE TIME OF PRODUCTION. WEBFORGE EXPRESSLY DISCLAIMS ALL LIABILITY WHATSOEVER FOR (INCLUDING ANY DIRECT OR INDIRECT LOSS OR DAMAGE, COSTS OR EXPENSES HOWSOEVER INCURRED BY ANY PERSON) RELIANCE ON THE WHOLE OR ANY PART OF THE INFORMATION CONTAINED IN OR OMITTED FROM THIS DRAWING. WEBFORGE RESERVES THE RIGHT TO MAKE TECHNICAL CHANGES WITHOUT NOTICE.

0	ISSUED FOR PUBLICATION	AJM	12/11/21
REV	DESCRIPTION	DATE	DRAWN
	DRAWN	AJM	CLIENT WEBFORGE
	DRAWN DATE	22/10/21	PRODUCT FLOORING
	APPROVED	JK	STANDARD STEEL GRATING - WELDING
	APPROVED DATE	12/11/21	DRAWING NUMBER FLGR-EX-001
PROJECTION			SHEET 1 of 1
DO NOT SCALE	<small>A valmont COMPANY</small>		REV 0
ALL DIMENSIONS IN mm U.N.O.			

6

5

4

3

2

1