



Standard Collection

Lighting

Traffic

Utility

Tramway

Telecom

valmont 
STANTON

To Our Customers

Dear Valued Customer,

Valmont Stainton was established nearly fifty years ago and throughout this time has been designing, manufacturing and supplying columns and masts to the UK construction industry.

As part of the Valmont Group, we have the strength and size of a global leader, with the depth and range of product that this brings, combined with the dedication and knowledge of the UK's largest lighting column manufacturer. Together we bring an unparalleled product offering with vast local specification experience to enable us to provide you with the pole solution you need!

Our passion for the poles we supply is as strong as ever and reflected in our striving to provide high quality products at the right time and at the right price!

While our brochure provides details and specifications of our many standard pole and mast products we can also utilise our experienced local engineering team, coupled with Valmont's robust worldwide product development and know how, to provide bespoke solutions which excite and at the same time give peace of mind.

Population growth and economic development are continually increasing the global demands for quality infrastructure and improved productivity. Valmont Stainton is committed to providing products and services that enhance the lives of our customers, employees, and communities, and to do so in an increasingly efficient and environmentally friendly manner.

As part of this commitment we provide products and services that support sustainable infrastructure development and work to improve our use of raw materials, energy and water in the manufacture of our products and provision of our services. We constantly strive to reduce the emissions, discharges and wastes that our operations generate.

Valmont Stainton has a rich history of success in engineered support structures, and we continue to pursue opportunities for development. Our company vision is strategically focused on customers, investors and employees; and we are proud of our results.

I appreciate your interest in Valmont Stainton and encourage you to explore our brochure to learn more about our commitment to continuous improvement, and our family of products and services available worldwide.

Jamie Taylor
Managing Director
Valmont Stainton Ltd



Standard Collection

| | | | | | |
|-------------------------|-----|-------------------------|-----|-----------------------------|-----|
| Valmont Global | 6 | | | Tubular Steel | 30 |
| Product Families | 8 | | | Parallel Steel | 32 |
| Design | 10 | | | Octagonal Steel | 34 |
| Engineering | 12 | | | SWT Conical Steel | 38 |
| Mixity | 14 | | | Altor | 42 |
| Environment | 16 | Steel | 20 | Fluance | 46 |
| Wind Zones EN40 | 18 | Aluminium | 22 | CityQuartz | 50 |
| Material Specs. | 20 | Wood | 24 | Shard | 52 |
| Steel Columns | 28 | Stainless | 26 | Tree Column 2 | 54 |
| | | Corten | 27 | Diamond Column | 56 |
| Aluminium Columns | 74 | | | Raked Column | 58 |
| Wooden Columns | 96 | | | XHD Column | 60 |
| Stainless Columns | 128 | | | Passive Safety | 62 |
| Corten Columns | 136 | | | CCTV | 64 |
| Hinged Columns | 142 | | | Slipper Columns | 68 |
| Large Mast Applications | 162 | | | VriPod | 70 |
| Infrastructure | 174 | | | Solar Columns | 72 |
| Applications Guide | 206 | | | | |
| Accessories | 220 | | | | |
| Finishes | 254 | | | Hinges | 222 |
| Annex | 268 | Projects | 270 | Security | 224 |
| | | Certificates | 298 | Banner Arms | 226 |
| | | Installation Foundation | 308 | Electrical Sockets | 228 |
| | | Terms and Conditions | 310 | Flood Light Adapters | 230 |
| | | Dimensional Key | 312 | Functional Lantern Brackets | 232 |
| | | General Recommendations | 314 | Decorative Lantern Brackets | 242 |
| | | Index | 315 | Accent Lighting | 250 |
| | | | | High Mast Accessories | 252 |





Navigation

The products in this brochure have been organised based on material or product type.

The Icon seen in the upper right-hand corner of the page indicates the pages content.

Tubular Aluminium 76

Conical Aluminium 78

Evolution 80

Candella 82

Diva² 84

Idylne 86

Sillem 90

Annapurna 92

Ceedji 94

Pallas 98

Inari 102

Koli 106

Ruka 110

Ontelo 114

Laine 118

Seka 120

Kartio 124

Bespoke 126

Severn 130

Mersey 132

Conway 134

Leven 144

Trent 146

Swale 148

Tay 150

Derwent 152

Dart 154

ROTA 156

Tyne 158

Humber 160

Sports Lighting 164

High Mast Lighting 166

Malto 172

Traffic Signals 176

Utility Columns 180

Tramway Poles 182

Telecom Masts 184

Smart Columns 186

Transportation 192

Heritage Products 194

Furniture 196

Sign Posts 204

Valmont

Global service, local presence

In 1946.

Robert Daugherty founded the Valmont Group in Valley, Nebraska. Valmont has always been innovative in designing many industrial machines making it possible to manufacture new products such as « Fluted Steel Columns ».

In 1978...

Valmont Stainton, commenced the manufacture of octagonal lighting columns and many of these columns are still gracing the motorways of the UK.

From our humble origins as the UK subsidiary of Petitjean S.A.S (a French pole manufacturer), a successful MBO and subsequent acquisition by Valmont Industries, Valmont Stainton is the largest manufacturer of UK lighting columns.

Today.

We are proud to be part of the largest pole manufacturing company in the world. Valmont is truly a global leader with activities as diverse as irrigation equipment, coatings, tubing and engineering structures.

Valmont supplies its products and services to more than 100 countries while operating over 20 manufacturing facilities, located on 6 continents.





Africa

Berrechid, Morocco
 Johannesburg, South Africa
 Nelspruit, South Africa

Australia

Acacia Ridge, Queensland
 Bassendean, Western Australia
 Bohle, Queensland
 Brisbane, Queensland
 Campbellfield, Victoria
 Carole Park, Queensland
 Clayton South, Victoria
 Girraween, New South Wales
 Hexham, New South Wales
 Launceston, Tasmania
 Mayfield, New South Wales
 Melbourne, Victoria
 Minto, New South Wales
 Mona Vale, New South Wales
 Pinkenba, Queensland
 Port Kembla, New South Wales
 Silverwater, New South Wales
 Welshpool, Western Australia

Canada

Barrie, Ontario
 Brantford, Ontario
 Delta, British Columbia
 Mississauga, Ontario
 Rexdale, Ontario
 St. Julie, Québec
 Winnipeg, Manitoba

China

Chengdu, Sichuan
 Guangzhou, Guangdong
 Haiyang, Shandong
 Heshan, Guangdong
 Shanghai
 Tianjin
 Wuxi, Jiangsu P.C.

Europe & Middle East

Charmeil, France
 Jebel Ali, U.A.E.
 Kangasniemi, Finland
 Kiiu, Estonia
 Maarheeze, The Netherlands
 Madrid, Spain
 Parikkala, Finland
 Rive-de-Gier, France
 Rødskro, Denmark
 Siedlce, Poland
 Stockton-on-Tees, UK

India

Mumbai
 Pune

Mexico

Monterrey

New Zealand

Christchurch
 Palmerston North

South America

Uberaba, Brazil

Southeast Asia

Cabuyao, Laguna, Philippines
 Cikarang, Bekasi, Indonesia
 Subang Jaya, Selangor, Malaysia
 Nilai, Negeri Sembilan, Malaysia
 Amphur Pluakdaeng, Rayong, Thailand
 Shah Alam, Selangor, Malaysia
 Trece Martires City, Cavite, Philippines

United States

Aurora, Colorado
 Barstow, California
 Bartow, Florida
 Bellville, Texas
 Brenham, Texas
 Chicago, Illinois

Claxton, Georgia
 Columbus, Nebraska
 El Dorado, Kansas
 Elkhart, Indiana
 Farmington, Minnesota
 Ferndale, Washington
 Hazleton, Pennsylvania
 Jasper, Tennessee
 Jeffersonville, Indiana
 Lindon, Utah
 Long Beach, California
 Los Angeles, California
 Mansfield, Texas
 McCook, Nebraska
 Miami, Florida
 Minneapolis, Minnesota
 Omaha, Nebraska
 Petersburg, Virginia
 Plymouth, Indiana
 Salem, Oregon
 Salina, Kansas
 Sioux City, Iowa
 Steele, Alabama
 Tampa, Florida
 Tualatin, Oregon
 Tulsa, Oklahoma
 Tuscaloosa, Alabama
 Valley, Nebraska
 Waverly, Nebraska
 West Columbia, South Carolina
 West Point, Nebraska

Product Families

Valmont Stainton

With an uncommon combination of global resources and local expertise, Valmont is the recognised leader in designing and producing engineered infrastructure products for the lighting, traffic, telecommunications, utility, and tramway industries worldwide.



Lighting

Valmont Stainton is the UK's leading manufacturer of galvanised steel, aluminium, stainless steel and wood lighting columns.

Designed to illuminate and inspire, Valmont Stainton has an extensive portfolio both decorative and functional solutions for outdoor lighting applications.



Tramway

Valmont Stainton provides tramway and traction poles for modern transportation systems.

Transportation planners increasingly are turning to Valmont Stainton to provide custom-engineered decorative and traditional structural supports for their tramway, traction and light-rail transit systems.



Traffic

Valmont Stainton designs and manufactures motorway and roadway traffic sign posts, bridges and related structures to provide strong, durable support for street-side and overhead traffic signage.



Utility

Valmont Stainton designs and produces transmission and distribution poles for electric power utilities.

With talented in-house engineers and proven experience, Valmont Stainton has the necessary tools to develop a solution for any utility pole structure.

Telecommunications

Valmont has global expertise in addressing the monopole and structural accessory needs of the telecommunications industry. Our monopoles are renowned for their durable designs and serve as the backbone for modern wireless communication networks.



Design

Industrial Design.

A process which is applied to products that will be manufactured through mass production techniques. The goal of the industrial design process is to develop products in a way that is mutually beneficial for both the end user and the manufacturer. The end goal of the process is to strike a balance between form, materials, manufacturing techniques, transport, installation, maintenance, aesthetics, and of course, cost.

Design is a process, not improvisation.

Projects may vary, but the starting point is always the same. An idea, a simple sketch on a piece of paper, a concept...

The initial idea is developed into the Design Brief which will serve as the foundation of the design. The design team's job is to guide the concept through the process of development, review, and refinement until said product is deemed to be ready for production.

Research, 2D sketches, 3D models, visualisations, and prototypes are all tools used by the design team to keep the project focused and ensure the intended design is conveyed to the engineering team.

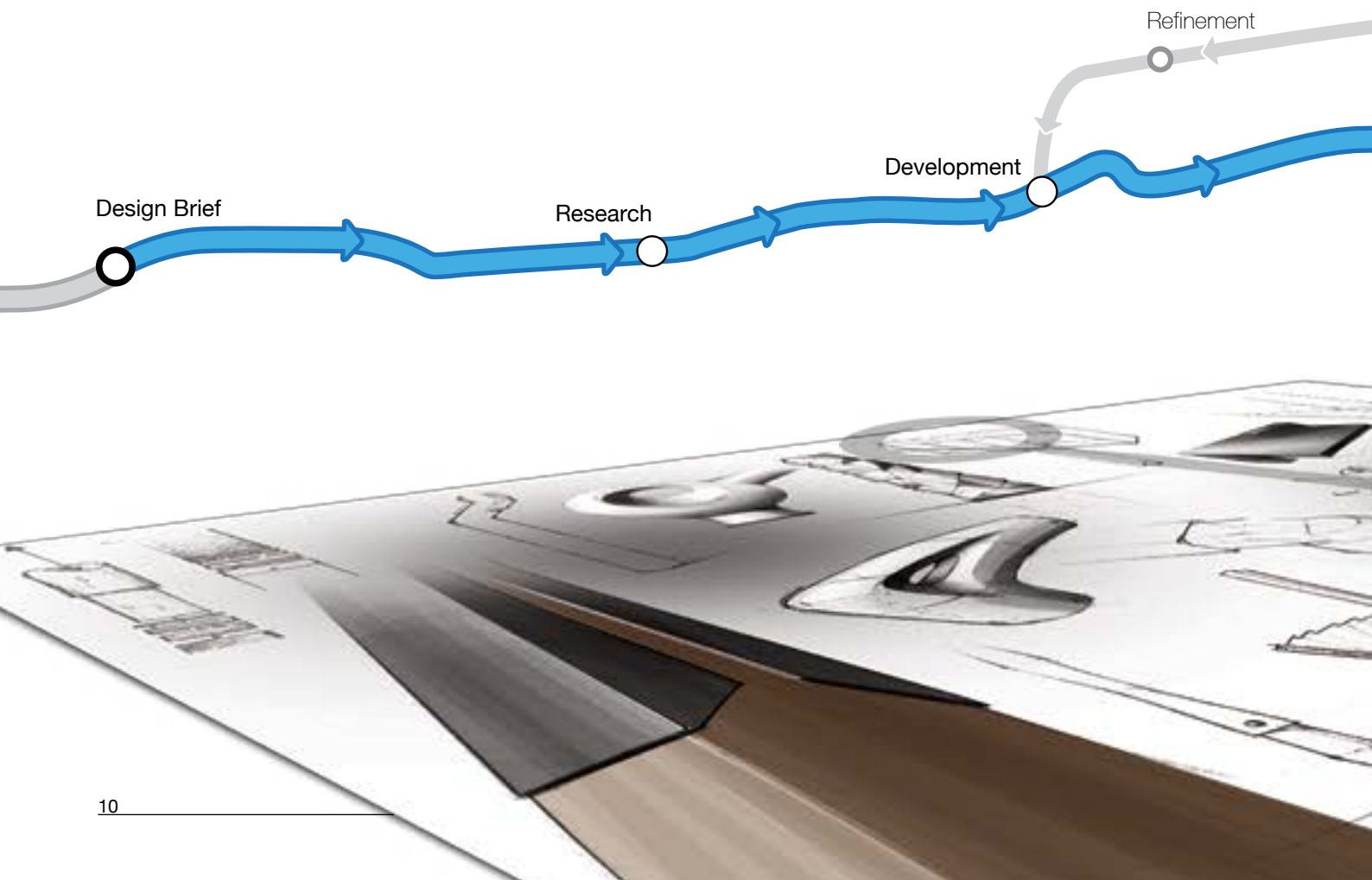

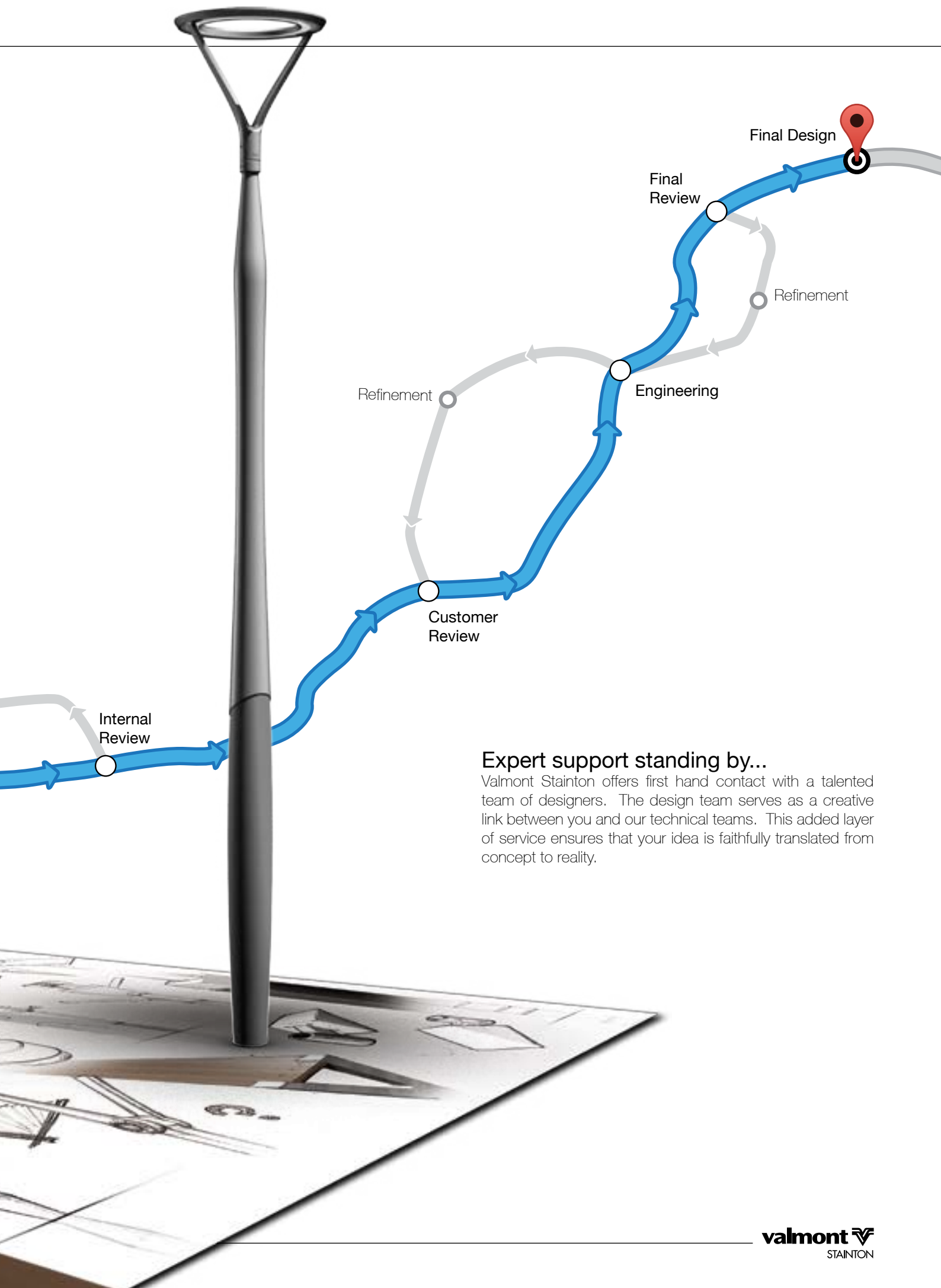

Expert support standing by...

Valmont Stainton offers first hand contact with a talented team of designers. The design team serves as a creative link between you and our technical teams. This added layer of service ensures that your idea is faithfully translated from concept to reality.

Engineering

From creation to production...

Each piece of lighting furniture Valmont produces is systematically developed and assessed in the light of aesthetic, technical, economic and environmental criteria.

Our engineering teams are dedicated to using the technology and expertise of the group which are best suited to the product:

- *By respecting the designer's work.
- *By keeping the visual impact of technical constraints to a minimum.
- *By ensuring an impeccable finish and at the same time limiting environmental impact.

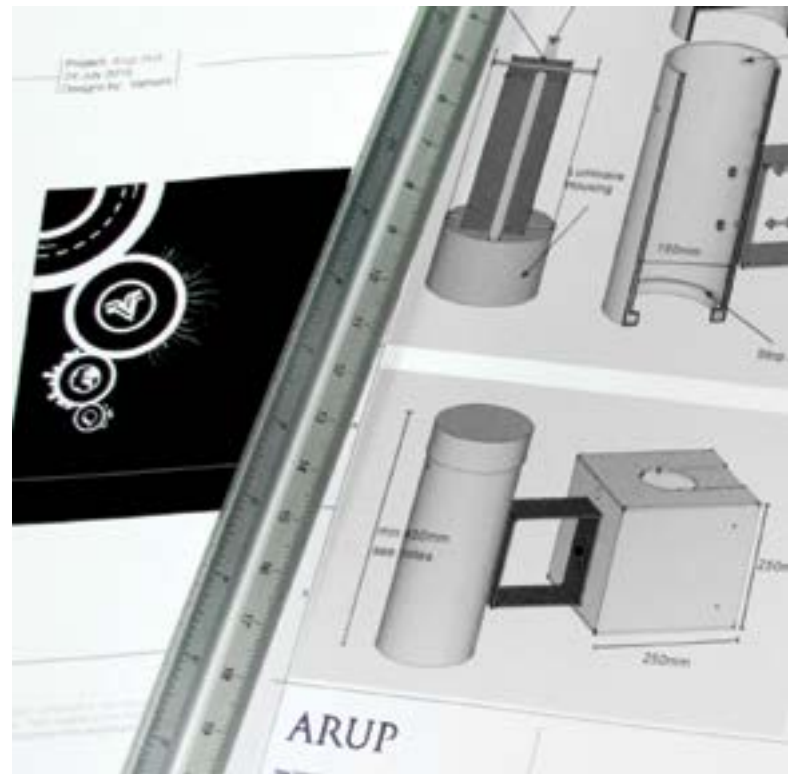

A consistent vision.

The systematic use of 3D at the industrial design stage makes it possible to visualise and validate each detail of the product. Linking it with the production tools ensures that the finished product is identical to the developed idea. All Steel, Aluminium and Wood Structures are subject to weather conditions such as wind and are developed in conformity with current regulations.

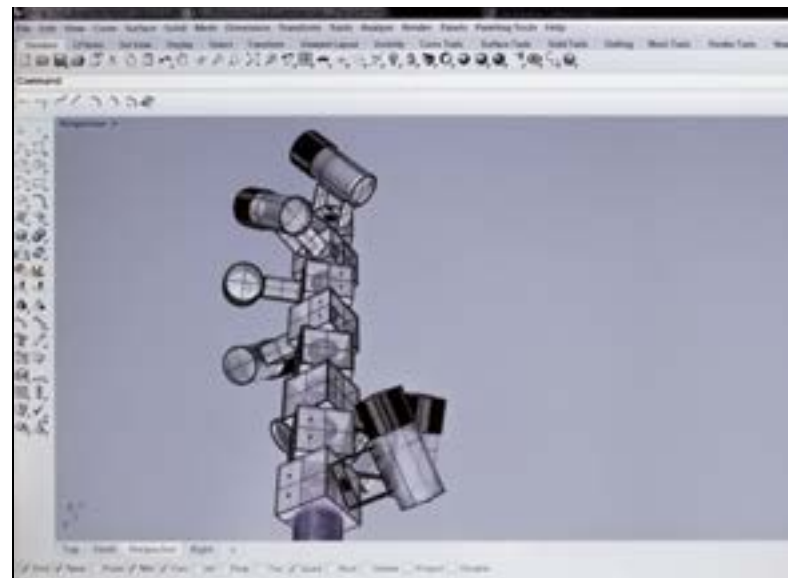

Mixity

Mixing materials, products, and skills to create new possibilities.

Valmont is unique in the column industry given our experience in a wide range of construction materials. It is this expertise that allows us to mix and match a wide range of materials and product types within the scope of a single project. Mixity opens the door to creativity and opportunity allowing for tailor-made solutions to match our customers technical, aesthetic and budgetary needs perfectly.



Mixing materials to serve product design.

Materials all have their own intrinsic properties. Valmont has a high level of experience with Steel, Aluminium, Laminated Timber, Polyester, Stainless Steel and even Corten Steel.

This level of flexibility enables Valmont to select the material or materials that are best suited for your project.

Mixing products to optimise large installations.

Valmont offers an extensive range of products covering a myriad of applications. This great range of options make it possible for design teams to realize their vision with an unparalleled degree of fidelity.

Think about a large installation such as a hospital, here we encounter multiple areas with varying uses. Entrance roads, refuse areas (for waste / rubbish / recycling), car parks (staff / visitor), social spaces for patients, main entrance, drop off points, children's play areas must all be addressed.

In the past, it was a common practice to select a single mid-ranged product and roll it out across the breadth of a project. While this method is effective, it is far from efficient. Mixture offers an alternative approach. If we are sensitive to the context of each area we can select "value added" solutions only where beneficial and lower calibre options in low traffic areas.

In our approach we maximise the use of "low end" and "high end" solutions with a sensitive consideration to the installation areas... Installing an anodized aluminium pole in refuse areas, waste? Using a stepped tubular galvanised finish pole in refuse areas, logical?

This approach is not ground breaking, but the prospect of dealing with multiple suppliers for individual products can be seen as high risk. Valmont offers you the opportunity to channel all of these products via a single source supplier bringing this added value approach within reach....



Wood Columns:
Entrance roads to site
and to main building



Aluminium Columns:
Car parks, access
roads, drop off points



Bespoke Columns:
Main Entrances, exits,
social spaces, and
children's play areas.

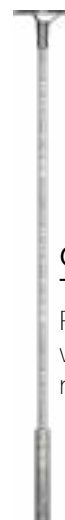

**Galvanised Step
Tubular Columns:**
Refuse areas (for
waste / rubbish /
recycling)

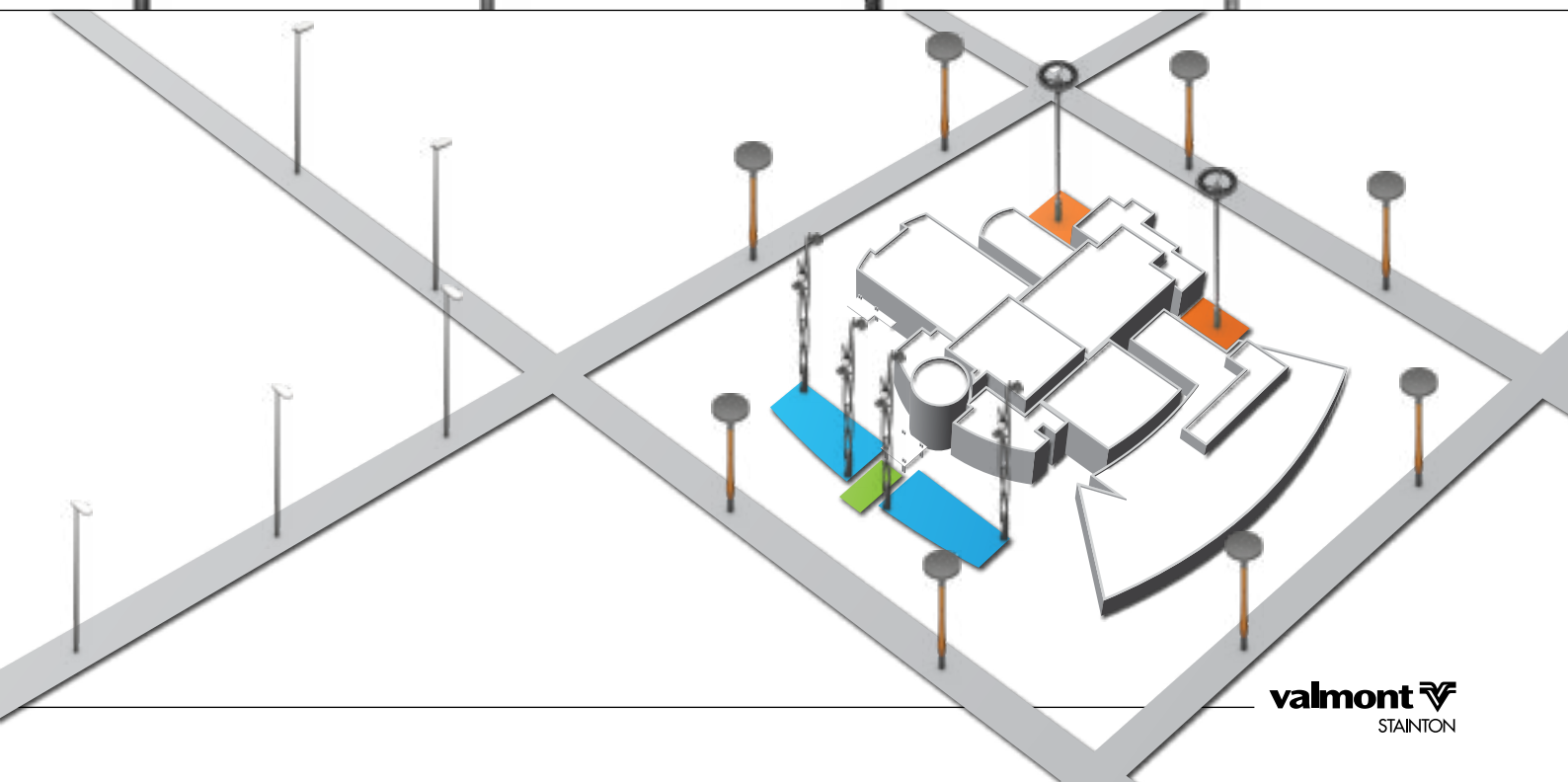

Environmental Responsibility

The Carbon Footprint.

Throughout their life cycle, from original raw material to final recycling, all products have an environmental impact.

There are many factors which can have a negative impact on the environment:

- *Greenhouse gas densification.
- *Necessary energy consumption.
- *Dangerous waste production.
- *The impact on air (toxicity and acidification).
- *The impact on water (toxicity and acidification).
- *Thinning of the ozone layer.

The scale of the task and considering the requirements outlined in the Kyoto Agreement (commitment to reduce greenhouse gases), Valmont has concentrated on its products' carbon footprint.



The amount of greenhouse gas emitted is calculated throughout a product's life cycle and is converted to equivalent CO₂ in order to obtain the carbon footprint.

This varies depending on the product (diametre, height, materials, etc.). Hence, in certain cases, choosing a laminated timber alternative can reduce the carbon footprint of your project by up to 40%.

To conduct the study completely objectively, Valmont collaborated with technical consultancy company REJLERS. Valmont can therefore provide the carbon footprint of each of its products.

As part of its Continuous Improvement Policy and along with its innovations, Valmont is committed to a process of reducing the environmental impact of its products.

Some points of progress:

- *By using High-Strength Steel for optimised design.
- *By using Aluminium incorporating 30% recycled matter.
- *By using waste recycling or treatment in plants.
- *Valmont France obtaining ISO 14001 Certification.
- *By optimising delivery routes.

Ultimately, our aim is to obtain the lowest possible carbon footprint for your projects, no matter which materials you choose to use...



The ZEP Program.

In an effort to further offset the environmental impact of our products, Valmont now works alongside the Trees for All organisation. Together, we have set up a parallel process aimed at compensating the residual CO₂ associated with the production of Valmont's columns.

Valmont is taking part in a program for planting Jatropha shrubs in Mali. The growth of these shrubs will absorb the equivalent CO₂ emitted during the production of your poles. The activity thus generated will be used to create a local social and economic balance.

Why Jatropha? These shrubs have been selected by the organisation based on their many environmental benefits:

- *Requires little care and can survive for 3 years without water.
- *Deep roots help fight soil erosion.
- *Jatropha hedges protect crops against animals.
- *Harvestable fruit with-in the first year after planting.



Thanks to Valmont's recent commitment, 19,540 shrubs (i.e. the equivalent of 977 tons of CO₂) were planted and allowed for many jobs to be created. This commitment is currently optional for the sale of our standard products.



Zero Emission Pole
by valmont 

Wind Zones EN40

Wind Loading Categories.

The rationalised wind loading factor, R_{wf} , are all stated at 10m above ground level and for a mean return period of 25 years.

Valmont Standard Lighting Columns are based on:

Terrain Category II

8m and above.

Terrain Category III

less than 8m.

| Wind Region |
|-------------|
| Extra Heavy |
| Heavy |
| Medium |
| Light |
| Extra Light |

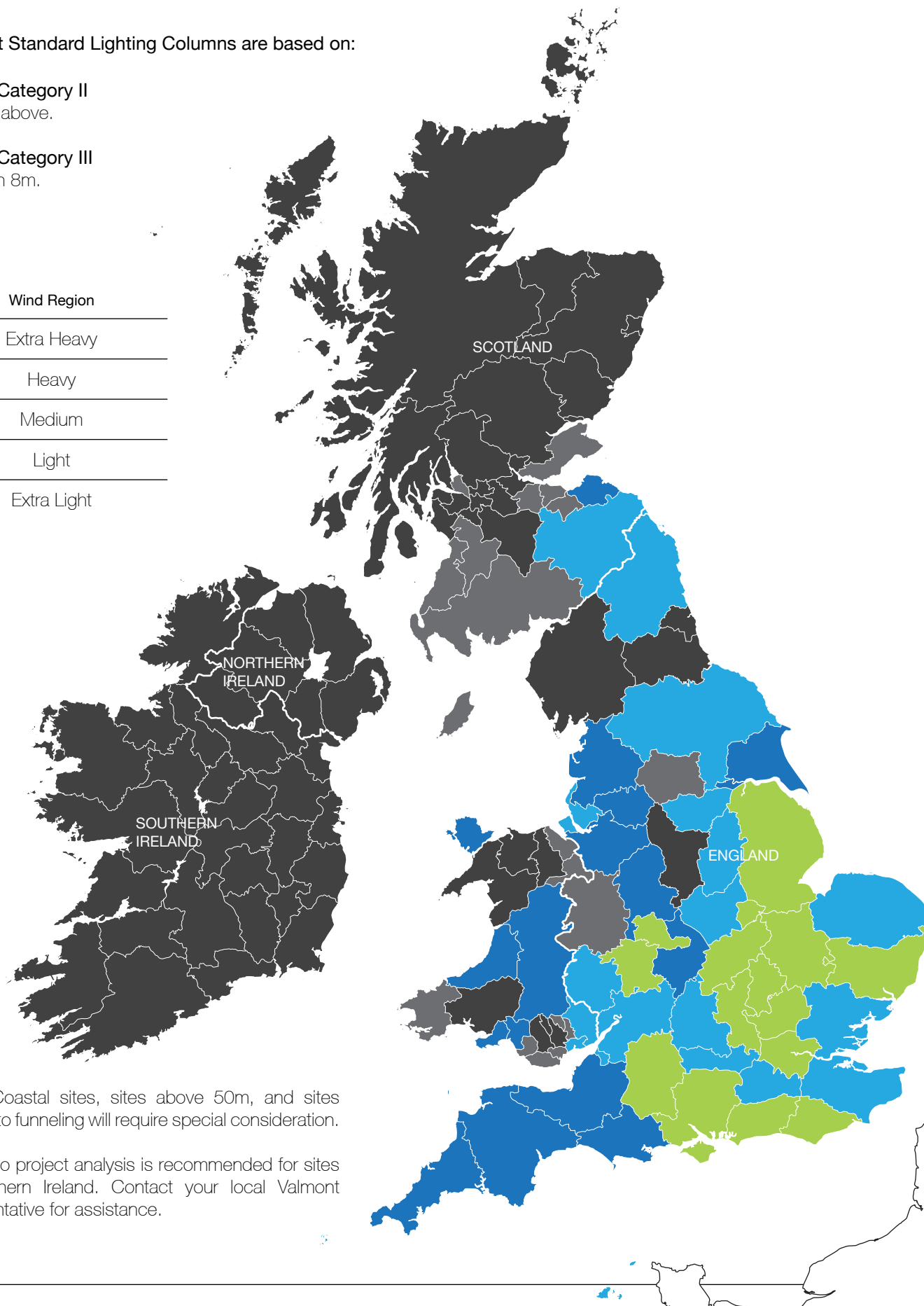

Note: Coastal sites, sites above 50m, and sites subject to funneling will require special consideration.

Project to project analysis is recommended for sites in Southern Ireland. Contact your local Valmont representative for assistance.

| County | 10 Min Mean Wind Speed (m/s) | Max Elevation | Alt. Adjusted Wind Speed (m/s) | Wind Region |
|----------------------------|------------------------------|---------------|--------------------------------|-------------|
| Aberdeen | 26 | 229 | 31,95 | Extra Heavy |
| Aberdeenshire | 27 | 184 | 31,97 | Extra Heavy |
| Angus | 26 | 229 | 31,95 | Extra Heavy |
| Antrim | 26 | 229 | 31,95 | Extra Heavy |
| Argyll & Bute | 28 | 141 | 31,95 | Extra Heavy |
| Armagh | 26 | 229 | 31,95 | Extra Heavy |
| Bath & North East Somerset | 22,5 | 226 | 27,59 | Medium |
| Bedfordshire | 22 | 132 | 24,90 | Extra Light |
| Blackburn with Darwen | 23,5 | 174 | 27,59 | Medium |
| Blackpool | 24 | 38 | 24,91 | Extra Light |
| Blaenau Gwent | 23 | 250 | 28,75 | Heavy |
| Bournemouth | 22 | 132 | 24,90 | Extra Light |
| Bracknell Fost | 21,5 | 159 | 24,92 | Extra Light |
| Bridgend | 23,5 | 223 | 28,74 | Heavy |
| Brighton & Hove | 22 | 132 | 24,90 | Extra Light |
| Bristol | 22,5 | 178 | 26,51 | Light |
| Buckinghamshire | 21,5 | 159 | 24,92 | Extra Light |
| Caerphilly | 23 | 250 | 28,75 | Extra Heavy |
| Cambridgeshire | 22 | 132 | 24,90 | Extra Light |
| Cardiff | 23 | 250 | 28,75 | Heavy |
| Cardiganshire | 24,5 | 250 | 30,63 | Extra Heavy |
| Ceredigion | 24,5 | 126 | 27,59 | Medium |
| Channel Islands | 24 | 104 | 26,50 | Light |
| Cheshire | 23,5 | 174 | 27,59 | Medium |
| Clackmannanshire | 25,5 | 250 | 31,88 | Extra Heavy |
| Conwy | 24,5 | 250 | 30,63 | Extra Heavy |
| Cornwall | 25 | 103 | 27,58 | Medium |
| Cumbria | 24,5 | 250 | 30,63 | Extra Heavy |
| Darlington | 23,5 | 60 | 24,91 | Extra Light |
| Denbighshire | 24 | 250 | 30,00 | Extra Heavy |
| Derby | 22 | 132 | 24,90 | Extra Light |
| Derbyshire | 22,5 | 178 | 26,51 | Light |
| Devon | 24 | 149 | 27,58 | Medium |
| Dorset | 23 | 199 | 27,58 | Medium |
| Down | 26 | 229 | 31,95 | Extra Heavy |
| Dumfries & Galloway | 26 | 106 | 28,76 | Heavy |
| Dundee | 25 | 250 | 31,25 | Extra Heavy |
| Durham | 24 | 250 | 30,00 | Extra Heavy |
| East Dunbartonshire | 25,5 | 250 | 31,88 | Extra Heavy |
| East Lothian | 24,5 | 126 | 27,59 | Medium |
| East Renfrewshire | 25,5 | 250 | 31,88 | Extra Heavy |
| East Riding of Yorkshire | 23 | 199 | 27,58 | Medium |
| East Sussex | 22 | 132 | 24,90 | Extra Light |
| Edinburgh | 24,5 | 173 | 28,74 | Heavy |
| Essex | 22,5 | 178 | 26,51 | Light |
| Falkirk | 25,5 | 250 | 31,88 | Extra Heavy |
| Fermanagh | 26 | 229 | 31,95 | Extra Heavy |
| Fife | 25 | 150 | 28,75 | Heavy |
| Flintshire | 24 | 198 | 28,75 | Heavy |
| Glasgow | 25,5 | 250 | 31,88 | Extra Heavy |
| Gloucestershire | 22,5 | 178 | 26,51 | Light |
| Greater London | 22 | 132 | 24,90 | Extra Light |
| Greater Manchester | 23,5 | 174 | 27,59 | Medium |
| Gwynedd | 25 | 250 | 31,25 | Extra Heavy |
| Halton | 23 | 83 | 24,91 | Extra Light |
| Hampshire | 22 | 132 | 24,90 | Extra Light |
| Hartlepool | 23,5 | 60 | 24,91 | Extra Light |
| Herefordshire | 23 | 152 | 26,50 | Light |
| Hertfordshire | 22 | 132 | 24,90 | Extra Light |
| Highland | 29,5 | 83 | 31,95 | Extra Heavy |
| Inverclyde | 26 | 229 | 31,95 | Extra Heavy |
| Isle of Anglesey | 25,5 | 82 | 27,59 | Medium |
| Isle of Man | 26 | 106 | 28,76 | Heavy |
| Isle of Wight | 22 | 132 | 24,90 | Extra Light |
| Isles of Scilly | 25 | 60 | 26,50 | Light |
| Kent | 22,5 | 178 | 26,51 | Light |
| Kingston upon Hull | 22,5 | 107 | 24,91 | Extra Light |
| Lancashire | 24 | 149 | 27,58 | Medium |
| Leeds City | 23 | 250 | 28,75 | Heavy |
| Leicester | 22 | 132 | 24,90 | Extra Light |
| Leicestershire | 22 | 204 | 26,49 | Light |
| Lincolnshire | 22,5 | 107 | 24,91 | Extra Light |
| Londonderry | 26,5 | 206 | 31,96 | Extra Heavy |
| Luton | 21,5 | 159 | 24,92 | Extra Light |

| County | 10 Min Mean Wind Speed (m/s) | Max Elevation | Alt. Adjusted Wind Speed (m/s) | Wind Region |
|--------------------------|------------------------------|---------------|--------------------------------|-------------|
| Medway | 22 | 132 | 24,90 | Extra Light |
| Merseyside | 23,5 | 128 | 26,51 | Light |
| Merthyr Tydfil | 23,5 | 250 | 29,38 | Extra Heavy |
| Mid Lothian | 24,5 | 173 | 28,74 | Heavy |
| Middlesbrough | 23,5 | 128 | 26,51 | Light |
| Milton Keynes | 22 | 132 | 24,90 | Extra Light |
| Monmouthshire & Newport | 23 | 152 | 26,50 | Light |
| Moray | 27 | 184 | 31,97 | Extra Heavy |
| Neath Port Talbot | 23,5 | 174 | 27,59 | Medium |
| Norfolk | 23 | 152 | 26,50 | Light |
| North Ayrshire | 26,5 | 206 | 31,96 | Extra Heavy |
| North East Lincolnshire | 22,5 | 107 | 24,91 | Extra Light |
| North Lanarkshire | 25,5 | 250 | 31,88 | Extra Heavy |
| North Lincolnshire | 22,5 | 107 | 24,91 | Extra Light |
| North West Somerset | 22,5 | 178 | 26,51 | Light |
| North Yorkshire | 23,5 | 128 | 26,51 | Light |
| Northamptonshire | 22 | 132 | 24,90 | Extra Light |
| Northumberland | 24,5 | 82 | 26,51 | Light |
| Nottingham | 22 | 132 | 24,90 | Extra Light |
| Nottinghamshire | 22,5 | 178 | 26,51 | Light |
| Orkney | 29,5 | 83 | 31,95 | Extra Heavy |
| Oxfordshire | 21,5 | 232 | 26,49 | Light |
| Pembrokeshire | 25 | 150 | 28,75 | Heavy |
| Perth & Kinross | 26,5 | 206 | 31,96 | Extra Heavy |
| Peterborough | 22 | 132 | 24,90 | Extra Light |
| Plymouth | 24 | 149 | 27,58 | Medium |
| Poole | 22 | 132 | 24,90 | Extra Light |
| Portsmouth | 22 | 132 | 24,90 | Extra Light |
| Powys | 23,5 | 174 | 27,59 | Medium |
| Reading | 21,5 | 159 | 24,92 | Extra Light |
| Redcar & Cleveland | 23,5 | 60 | 24,91 | Extra Light |
| Renfrewshire | 26 | 229 | 31,95 | Extra Heavy |
| Rhondda Cynon Taff | 23,5 | 250 | 29,38 | Extra Heavy |
| Rutland | 22 | 132 | 24,90 | Extra Light |
| Scottish Borders | 24,5 | 82 | 26,51 | Light |
| Shropshire | 23 | 250 | 28,75 | Heavy |
| Slough | 21,5 | 159 | 24,92 | Extra Light |
| Somerset | 23,5 | 174 | 27,59 | Medium |
| South & East Ayrshire | 26 | 106 | 28,76 | Heavy |
| South Gloucester | 22,5 | 178 | 26,51 | Light |
| South Lanarkshire | 25,5 | 250 | 31,88 | Extra Heavy |
| South Yorkshire | 22,5 | 178 | 26,51 | Light |
| Southampton | 22 | 132 | 24,90 | Extra Light |
| Southend | 22 | 132 | 24,90 | Extra Light |
| Staffordshire | 22,5 | 226 | 27,59 | Medium |
| Stirling | 26,5 | 206 | 31,96 | Extra Heavy |
| Stockton-on-Tees | 23,5 | 128 | 26,51 | Light |
| Stoke-on-Trent | 22,5 | 226 | 27,59 | Medium |
| Suffolk | 23 | 83 | 24,91 | Extra Light |
| Surrey | 21,5 | 232 | 26,49 | Light |
| Swansea | 24 | 149 | 27,58 | Medium |
| Swindon | 21,5 | 159 | 24,92 | Extra Light |
| Telford & Wrekin | 22,5 | 226 | 27,59 | Medium |
| Thurrock | 22 | 132 | 24,90 | Extra Light |
| Torbay | 23,5 | 128 | 26,51 | Light |
| Torfaen | 23 | 250 | 28,75 | Heavy |
| Tyne & Wear | 24 | 250 | 30,00 | Extra Heavy |
| Tyrone | 26,5 | 206 | 31,96 | Extra Heavy |
| Vale of Glamorgan | 23,5 | 223 | 28,74 | Heavy |
| Warrington | 23 | 83 | 24,91 | Extra Light |
| Warwickshire & Coventry | 22 | 250 | 27,50 | Medium |
| West Berkshire & Newbury | 21,5 | 232 | 26,49 | Light |
| West Dunbartonshire | 26 | 106 | 28,76 | Heavy |
| West Lothian | 25 | 150 | 28,75 | Heavy |
| West Midlands | 22 | 132 | 24,90 | Extra Light |
| West Sussex | 22 | 132 | 24,90 | Extra Light |
| West Yorkshire | 23 | 250 | 28,75 | Heavy |
| Western Isles | 31 | 31 | 31,96 | Extra Heavy |
| Wiltshire | 22 | 132 | 24,90 | Extra Light |
| Windsor & Maidenhead | 21,5 | 159 | 24,92 | Extra Light |
| Worcestershire | 22,5 | 107 | 24,91 | Extra Light |
| Workingham | 21,5 | 159 | 24,92 | Extra Light |
| Wrexham | 23,5 | 223 | 28,74 | Heavy |
| York | 23 | 83 | 24,91 | Extra Light |

Material Specifications Steel

Steel.

Our Columns and brackets are produced from S235, S275 and or S355 High strength steels, these grades of steel conform with the following standards:

EN10149 – Hot rolled flat products of high yield strength steels for cold forming.

EN10210 – Hot finished structural hollow sections of non-alloy and fine grain structural steels.

EN10219 – Cold formed structural hollow section of non-alloy fine grain steels.

EN10025 – Hot rolled products of non-alloy structural steels – Technical delivery conditions (includes amendment A1:1993)

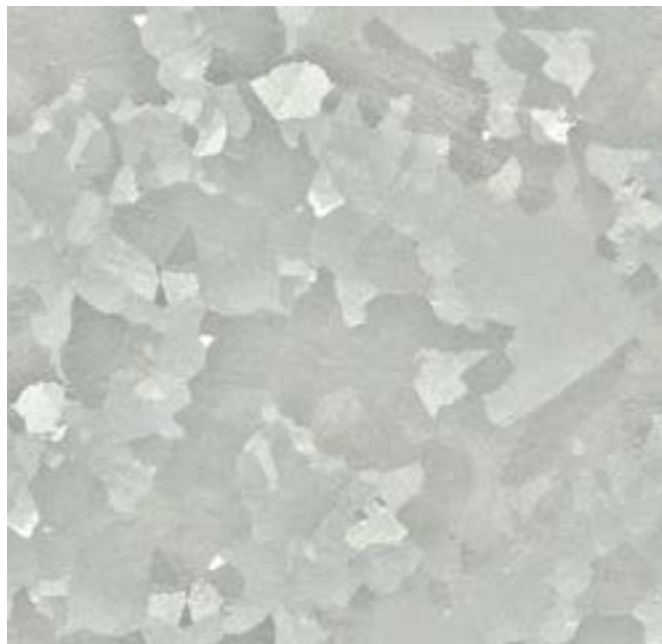

Galvanising.

In order to obtain the best quality galvanising for our products, all steel used is closely monitored for silicon content and it's suitability for the galvanising processes. The galvanising process and testing fully complies with BS EN ISO 1461:1999.

Hot rolled flat products in High-Strength Steel obtained by cold shaping:

This new Steel is obtained by the addition of microalloy elements (Titanium, Niobium, Vanadium...), which increases its resistance and makes it easier to weld, whilst maintaining good cold deformation. It also has better corrosion resistance.

Hot rolled products are made of type S235 Construction Steel :

Alloy composed mainly of Iron with Carbon to which different elements (Manganese, Silicon, etc.) are added in order to obtain minimal mechanical resistance.

| | S235 | S355 | S420 |
|-----------------------------------|------|------|------|
| ES: Elastic Stretch (Mpa) | 235* | 355 | 420 |
| TS: Tensile Strength (Mpa) | 360* | 430 | 480 |
| E: Elongation % | 17 | 19 | 18 |

*Strength values vary according to sheet metal thickness.

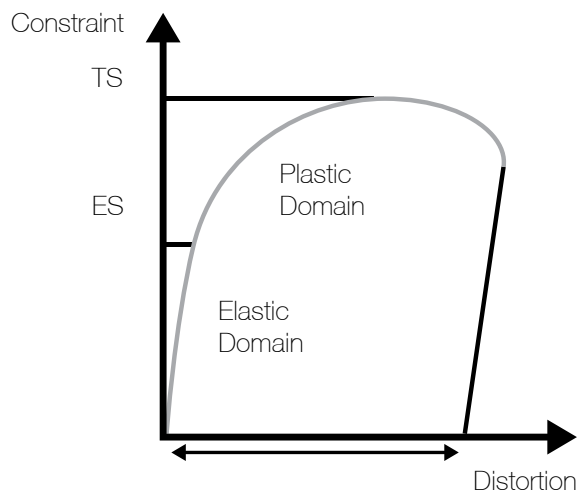

Tubular Column Production Line

The manufacturing of Valmont Stainton tubular columns begins with the cutting of the chosen tube to the correct length for the base of the column. The tube is then thoroughly de-burred at the point of the cut ensuring no sharp edges are left on the tube.



We then need to shape the base at the cutting point to receive the shaft. This is done by applying pressure to the base with dies. These dies control the shape of the base, we can choose different dies to accommodate a wide range of shaft diameters.

After the shaping of the base we then need to put the door and the cable slot in the desired place. This is done by an automated plasma burner that can be programmed to whatever shape and size of our choosing.



Once the door and cable slot have been cut out the base can then be sent to final assembly where the shaft can be fitted. The shaft can be shaped in the same manner as the base to receive all sorts of different bracket fittings.

During assembly the back plates are welded into the base compartment ready to receive the base board. Any other internal fittings are welded into the base at this stage.

Galvanizing

Once the manufacturing processes are completed, the columns are packed and made ready for galvanizing.

Galvanizing is the process of applying a protective zinc coating to steel. This coating reduces the likelihood of rust and greatly extends the life of the material. Valmont Stainton's steel products are hot-dip galvanised to ensure an even coating on both external and internal surfaces of the product.



After galvanising, the columns are inspected.

They are straightened manually by qualified operators capable of evaluating the straightness of the products. This is necessary to correct any distortion that may occur due to the heat of the galvanising process.

The drilling and tapping of holes at the top of the columns is performed.

Doors are assembled and fitted, along with the accessories of the base compartment (backboards, earth screws, etc.).

Any specific operations seen to be necessary are performed, followed by the final inspection of the product before sending to the client, putting in storage or sending for wet painting or powder coating.

Material Specifications Aluminium

Aluminium.

Our poles are produced from 6060T5 Aluminium alloy, the brackets and other tubular elements from 6060T6 alloy, the backing plates from 5038H111, the resistance elements from AISi7Mg or AISi10Mg cast Aluminium and decorative parts in AISi13 cast Aluminium.

These Aluminium alloys comply with NF EN 755 series standards for conical posts, brackets and other tubular parts as well as backing plates, and standard NF EN 1706 for parts in cast Aluminium.



Bars, tubes and spun profiles - 6060T5 or T6:

The mechanical characteristics are obtained by tempering and rendering. Valmont's specific rendering treatment makes it possible to obtain above-standard mechanical characteristics.

The 6060 alloy is a good compromise between mechanical strength and corrosion; it is particularly apt for anodising and cold deforming. Good welding results are obtained with classic procedures under inert gas (TIG or MIG).

Piece of cast Aluminium AISi7Mg and AISi10Mg:

There are two main casting processes used - sand or shell - according to the geometrical complexity of the product, the degree of precision needed for the dimensions and the quantities to be produced.

According to the level of resistance required, the pieces can be heat treated.

| | 6060 T6 | 6060 t5 | 5083 H111 |
|-----------------------------------|---------|---------|-----------|
| ES: Elastic Stretch (Mpa) | 150 | 180 | 110 |
| TS: Tensile Strength (Mpa) | 190 | 220 | 270 |
| E: Elongation % | 8 | 10 | 12 |

*Strength values vary according to sheet metal thickness.

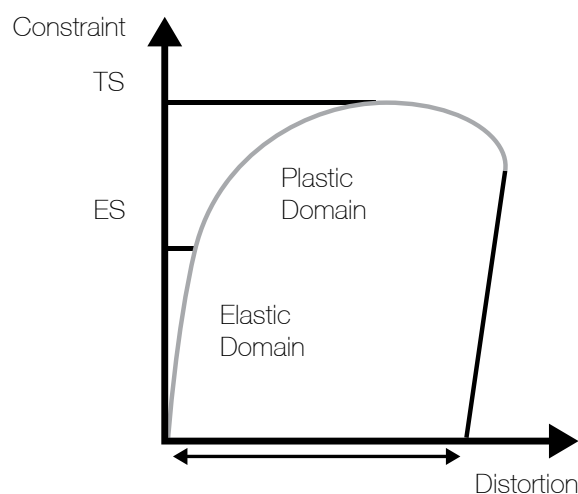

The Aluminium Process.

Valmont aluminium columns are formed via cold tapering.

After the aluminium tubes have been received and stocked in the production workshop, the tubes are then cut to length according to the technical specifications of the products to be manufactured, and automatically put into a storeroom for rough products. When they leave the storeroom, the tubes are automatically taken to the tapering machine.



The tapering operation consists of cold embossing the raw tubes to give them the required shape. This process is called cold spinning treatment.)

This spinning machine is made of a broach and a tailstock, which turns the raw shaft, then a shaping carriage made up of specific rollers moves along it and models the product following the technical specifications programmed into the machine.

Depending on the size of the end products, 1, 2, 3 or 4 can be made from one raw shaft. Once tapered, the raw shaft is moved to a saw bench where it will be cut to length. This whole tapering process is entirely automatic: the 3D product models made by our design department are directly sent to the machine's digital controls; the operator checks the data and then launches the production process.

This expertise and the machine's technical abilities allow us to produce complex shapes and obtain large tapering ratios.

The Aluminium Production Line.

A rendering furnace, where the rough tapered tubes are heated for 6 hours to acquire the mechanical strength fixed by our technical specifications. The products are checked as they leave the furnace to ensure that our products are well above minimum values.

After cooling, the tapered tubes are straightened and sent to the polishing line. 2 polishing operations are performed on 2 specific machines: the first gives a rough polish and the second carries out the finishing, which gives the end product that brushed and polished appearance.

The next stage is cutting the door. The tapered tube is held in clamps and a horizontal saw with a thin band saw blade does the cutting. Thus the door is perfectly adjusted in relation to the shape cut in the column. On the same machine, we reinforce the opening if necessary. This operation consists of expanding a strengthening tube inside the pole.

The last stage on this line is welding the base plates; this is done by qualified welders.



The column thus produced are moved to a storage zone within the factory.

Access doors are equipped and assembled.

Any specific operations seen to be necessary are performed, followed by the final control before individual packing and sending them to the client, putting them in stock or sending them for painting on our powder coating line.

Material Specifications Wood

Wood.

Our poles are made from planks of Class 3 glue-laminated untreated Scots Pine beams.

Our beams are designed and certified **GL28h**. There are 4 classes of resistance, GL24, 28, 32 and 36h, by increasing order of resistance.



Glue Laminated Beams.

The maximum thickness of the planks making up the beam is less than 34mm, in conformity with Eurocode 5 registered as "Mixed Wood Metal Lamp posts".

The glue used to assemble the planks is known as White glue, and has the advantage of minimising the visual impact of joints on the wooden parts.

Like the Scotch pine from Finland used for our production, our end products are PEFC* certified, certificate 5674-01.

Steel Components.

The metal parts of these "Mixed Wood Metal Lighting Columns" are made of S235 Galvanised Steel. To obtain the best quality Galvanising, the Steel used is category A in conformity with standard NF A 35-503.

Hot rolled products made of type S235 Construction Steel:

Alloy composed mainly of Iron with Carbon to which different elements (Manganese, Silicon, etc.) are added in order to obtain minimal mechanical resistance.

| | GL24h | GL28h | GL32h | GL36h |
|----------------------------------|-------|-------|-------|-------|
| Deflection (N/mm ²) | 24 | 28 | 32 | 36 |
| Tension (N/mm ²) | 16.5 | 19.5 | 22.5 | 26 |
| Compression (N/mm ²) | 24 | 26.5 | 29 | 31 |
| Density (kg/m ³) | 380 | 410 | 430 | 450 |



Wooden Column Production.

Our production line for wooden columns transforms GL28h laminated pine beams into mixed Steel/Wooden columns, entirely finished with base plate and equipment inside the door. Once production is complete, the columns are sent directly to clients.

The Production Line: The manufacturing of the masts begins by cutting off the extremities of the beam according to the height of the final product. Next, a central hole is drilled along the length of the column to allow cabling to pass.

Cylindrical section columns are produced using the same machining centre. Initially all cylindrical section columns have a multi-faceted profile. Depending on the final design, the column may then be sanded in order to smooth these facets and obtain the final shape.



Square-section columns are produced by a digital machining centre. Also at this point, additional cuts are made in wood to allow the steel base and top cap to be fitted.

Standard columns of heights taller than 5m are produced in several parts. The parts of the column go through a digital machining centre where finger joints are placed on the end surfaces to be joined. The joining and gluing operations needed to ensure a strong and permanent connection are performed next.

The assembly technology used to produce these columns complies with current calculation rules.

Finishing.

All holes needed to fix accessories and/or lights are then made in the wooden column as per the required specification.

All columns are then treated to a 4 layer protective coating system which is designed to maximise the life span of the wooden column.



The steel base, is then securely fitted and glued to the pole. The adapters or other parts designed to fasten lanterns and/or accessories are also put into position at this time. Once all fasteners are installed the products are then packaged for delivery.



Packaging:

Several thicknesses of corrugated cardboard protect the wooden section, while a felt sleeve protects the steel base.

The columns are then placed top to bottom on a pallet, separated from each other by wooden wedges which follow the section of the mast to avoid slipping during transport.

The operator takes care to balance the pallet according to the weight and length of the masts. Placing its centre of gravity directly above the position of the pallet truck forks. The bundle is further protected by a wooden plaque in order to prevent any damage from forks. Lastly, a plastic film is added to ensure that rain cannot deteriorate the cardboard envelope packaging during transport.

Material Specifications Stainless and Corten

Stainless Steel.

Our columns and brackets are produced from Grade 304L & 316L austenitic stainless steel, these types of steel conform with following standards:

EN10088-2:– Stainless Steel.

1.4301 - XBS1449 – Grade 304L

1.4401 - XBS1449 – Grade 316L



Corrosion Resistance.

The corrosion resistance of stainless steel is attributed to the thin passive film that forms spontaneously on its surface in oxidizing environments if the steel has a minimum chromium content of approximately 10.5%. (Which both Gr304L and 316L do).

As the film adheres strongly to the metal substrate and protects it from contact with the surrounding environment, the electrochemical reactions that cause corrosion are effectively stopped. If locally destroyed, for example by scratching, the film can 'heal' by spontaneously re-passivating in an oxidizing environment.

Finishing.

As for the finishing of our stainless steel products, Due to largely being used as roadside structures we opt for a process of stainless steel bead abrading, to create a homogenous automated satin finish, which can be sealed with a clear coating on request. Both mirror finishing and electroplating are available for decorative stainless structures, although are not advised for roadside due to glare issues.

| | 1.4301 | 1.4401 |
|-----------------------------------|--------|--------|
| ES: Elastic Stretch (Mpa) | 200 | 220 |
| TS: Tensile Strength (Mpa) | 500 | 520 |
| E: Elongation % | 45 | 45 |

*Strength values vary according to sheet metal thickness.

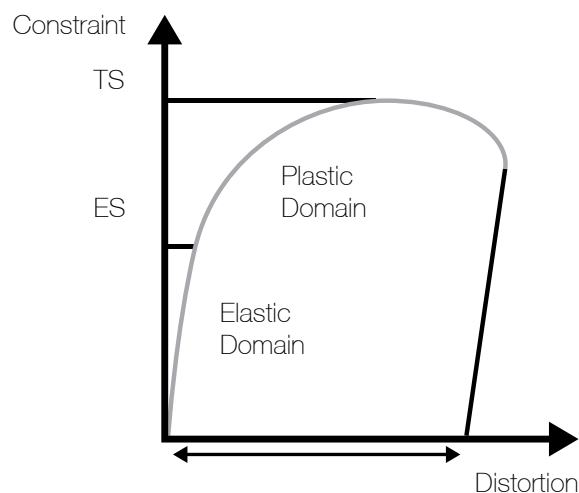



Corten Steel.

Corten is a weather-resistant steel alloy that has been optimized with copper, chromium, nickel and phosphorus. When exposed to weather, Corten steel develops a rich patina which protects and has greatly boosted its popularity over the last few years.

Valmont offers this product range in two different finishing options as standard.

Valmont Corten products are designed to meet EN 40-5 standards and carry CE Certification.

Corten Finish Options.

Valmont offers this product range in two different finishing options as standard.

The Natural Finish.

This process is carried out to provide Corten steel a natural patina, that will result as a natural, living Corten surface.

The process starts with cleaning of the product surfaces to remove grease and any other impurities. After this the product is starting to corrode from ambient humidity. This procedure continues and accelerates once installed (environmental effects, rain and drying) and finally the product will achieve the final stage of natural patina. Depending on the location and conditions this typically takes several months.

As this method complements Corten steel's natural characteristics, some staining (clothes etc.) may occur if the product is touched by individuals.

The Accelerated Finish.

This process features accelerated patina build-up, which provides good homogeneity of the surface finish. The rusting process is activated with a chemical, which is applied at least twice. After 3-4 days the rusting process has typically achieved its characteristics. At this point the level of rust is inspected visually, and should the aesthetics demand, additional chemical treatment with the same substance can be performed.

When the corrosion level has reached the customer's visual demand a stopping bath is applied to halt any further corrosion. This water-based acrylic sealant also reduces Corten steel's staining features substantially.

Steel Columns Functional and Decorative Steel



Project Lead: Stockton Borough Council | Installation: Ingleby

Galvanised Steel



Tubular Steel
Parallel Steel
Octagonal Steel
SWT Conical Steel
Altor
Fluance
CityQuartz
Shard
Tree Column 2
Diamond Column
Raked Conical
XHD Column
Passive Safety
CCTV
Slipper Columns
VriPod
Solar Columns



Tubular Steel



Description

Tubular steel columns are perfect for post top applications as well as bracket mounted configurations. Demountable or integral bracket arm arrangements can be selected to best suit the application.

Specifications

Valmont Stainton manufactures a wide range of tubular steel lighting columns from 4 to 15.

Valmont Stainton operates a Quality Assurance system which complies with requirements of BS EN ISO 9001.

Our welders and welding procedures are independently certified in accordance with 288EN ISO 9606 and EN ISO 15607.

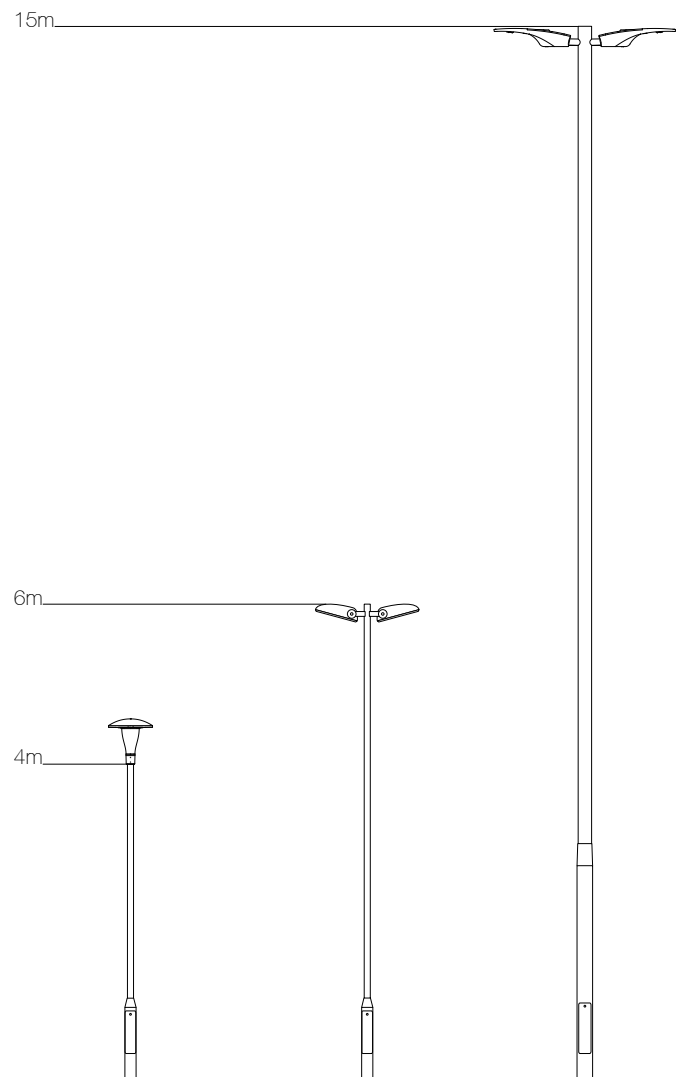



Dimensional Information

Planted Root Option

| Height (m) | BD (mm) | SD (mm) | BH (mm) | SH (mm) | PD (mm) | DH x DW (mm) | Mass (kg) | OTM (kNm) | Shear (kN) | Min. Concrete Dia. (mm) |
|------------|---------|---------|---------|---------|---------|--------------|-----------|-----------|------------|-------------------------|
| 4 | 139,7 | 76,1 | 1075 | 2925 | 800 | 500 x 100 | 34,8 | 4,42 | 1,34 | 540 |
| 5 | 139,7 | 76,1 | 1075 | 3925 | 800 | 500 x 100 | 39,7 | 4,23 | 1,18 | 500 |
| 6 | 139,7 | 76,1 | 1075 | 4925 | 1000 | 500 x 100 | 46,7 | 4,17 | 1,14 | 260 |
| 7 | 139,7 | 76,1 | 1200 | 5800 | 1000 | 500 x 100 | 51,4 | 4,10 | 1,07 | 250 |
| 8 | 168,3 | 88,9 | 1200 | 6800 | 1200 | 600 x 115 | 88,1 | 9,74 | 1,50 | 340 |
| 10 | 168,3 | 114,3 | 1200 | 8800 | 1500 | 600 x 115 | 124,5 | 15,06 | 2,19 | 270 |
| 12 | 193,7 | 139,7 | 1200 | 10800 | 1700 | 600 x 115 | 174,9 | 22,47 | 2,60 | 280 |
| 15 | 193,7 | 168,3 | 1200 | 13800 | 2000 | 600 x 115 | 306 | 40,30 | 4,11 | 300 |

Flange Plated Option

| Height (m) | BD (mm) | SD (mm) | BH (mm) | SH (mm) | DH x DW (mm) | SL x T x BC (mm) | Anchor Bolts | Mass (kg) | OTM (kNm) | Shear (kN) | Concrete Foundation Sizes (mm) |
|------------|---------|---------|---------|---------|--------------|------------------|--------------|-----------|-----------|------------|--------------------------------|
| 4 | 139,7 | 76,1 | 1075 | 2925 | 500 x 100 | 260 x 15 x 200 | M18 x 400 | 34,8 | 4,42 | 1,34 | 400 sq x 600 h |
| 5 | 139,7 | 76,1 | 1075 | 3925 | 500 x 100 | 260 x 15 x 200 | M18 x 400 | 39,7 | 4,23 | 1,18 | 400 sq x 600 h |
| 6 | 139,7 | 76,1 | 1075 | 4925 | 500 x 100 | 260 x 15 x 200 | M18 x 400 | 46,7 | 4,17 | 1,14 | 400 sq x 600 h |
| 7 | 139,7 | 76,1 | 1200 | 5800 | 500 x 100 | 260 x 15 x 200 | M18 x 400 | 51,4 | 4,10 | 1,07 | 400 sq x 600 h |
| 8 | 168,3 | 88,9 | 1200 | 6800 | 600 x 115 | 420 x 20 x 300 | M24 x 820 | 88,1 | 9,74 | 1,50 | 500 sq x 800 h |
| 10 | 168,3 | 114,3 | 1200 | 8800 | 600 x 115 | 420 x 20 x 300 | M24 x 820 | 124,5 | 15,06 | 2,19 | 600 sq x 1000 h |
| 12 | 193,7 | 139,7 | 1200 | 10800 | 600 x 115 | 420 x 20 x 300 | M24 x 820 | 174,9 | 22,47 | 2,60 | 700 sq x 1100 h |
| 15 | 193,7 | 168,3 | 1200 | 13800 | 600 x 115 | 420 x 30 x 300 | M24 x 820 | 306,0 | 40,30 | 4,11 | 1100 sq x 1300 h |

Headload Capacity Information

| Height (m) | Mounting Arrangement | Projection (m) | Weight (kg) | Extra Light | Light | Medium | Heavy | Extra Heavy |
|------------|----------------------|----------------|-------------|-------------|-------|--------|-------|-------------|
| 4m | Post Top | N/A | 50 | 1,00 | 0,87 | 0,79 | 0,72 | 0,56 |
| | Single Arm | 0,5 | 15 | 0,69 | 0,59 | 0,54 | 0,49 | 0,38 |
| | Double Arm | 0,5 | 15 | 0,46 | 0,39 | 0,35 | 0,32 | 0,24 |
| 5m | Post Top | N/A | 50 | 0,59 | 0,50 | 0,45 | 0,40 | 0,29 |
| | Single Arm | 0,5 | 15 | 0,48 | 0,41 | 0,36 | 0,32 | 0,22 |
| | Double Arm | 0,5 | 15 | 0,26 | 0,22 | 0,19 | 0,17 | 0,11 |
| 6m | Post Top | N/A | 30 | 0,38 | 0,31 | 0,27 | 0,23 | 0,15 |
| | Single Arm | 0,5 | 15 | 0,29 | 0,23 | 0,20 | 0,16 | 0,09 |
| | Double Arm | 0,5 | 15 | 0,14 | 0,11 | 0,09 | 0,07 | 0,03 |
| 7m | Post Top | N/A | 15 | 0,24 | 0,18 | 0,15 | 0,11 | 0,04 |
| | Single Arm | 0,5 | 15 | 0,14 | 0,09 | 0,07 | 0,04 | 0,00 |
| | Double Arm | 0,5 | 15 | 0,05 | 0,00 | 0,00 | 0,00 | 0,00 |
| 8m | Post Top | N/A | 30 | 0,42 | 0,36 | 0,32 | 0,30 | 0,21 |
| | Single Arm | 1 | 15 | 0,33 | 0,26 | 0,22 | 0,19 | 0,12 |
| | Double Arm | 1 | 15 | 0,15 | 0,11 | 0,09 | 0,07 | 0,00 |
| 10m | Post Top | N/A | 40 | 0,46 | 0,40 | 0,36 | 0,32 | 0,25 |
| | Single Arm | 1,5 | 15 | 0,31 | 0,25 | 0,21 | 0,18 | 0,12 |
| | Double Arm | 1,5 | 15 | 0,15 | 0,11 | 0,09 | 0,07 | 0,03 |
| 12m | Post Top | N/A | 40 | 0,62 | 0,55 | 0,51 | 0,48 | 0,34 |
| | Single Arm | 1,5 | 15 | 0,34 | 0,29 | 0,26 | 0,23 | 0,13 |
| | Double Arm | 1,5 | 15 | 0,22 | 0,19 | 0,16 | 0,14 | 0,07 |
| 15m | Post Top | N/A | 70 | 0,93 | 0,76 | 0,66 | 0,56 | 0,33 |
| | Single Arm | 2 | 15 | 0,54 | 0,42 | 0,34 | 0,27 | 0,12 |
| | Double Arm | 1,5 | 15 | 0,35 | 0,26 | 0,21 | 0,15 | 0,04 |

Dimensions and technical information given as an indication.

See diagrams beginning on page 308 for info regarding the moments and abbreviations used in above tables.

Valmont reserves the right to make, without delay and without prior notice, the technical or aesthetic modifications that it deems necessary to improve the products of the Standard Collection.

Parallel Steel

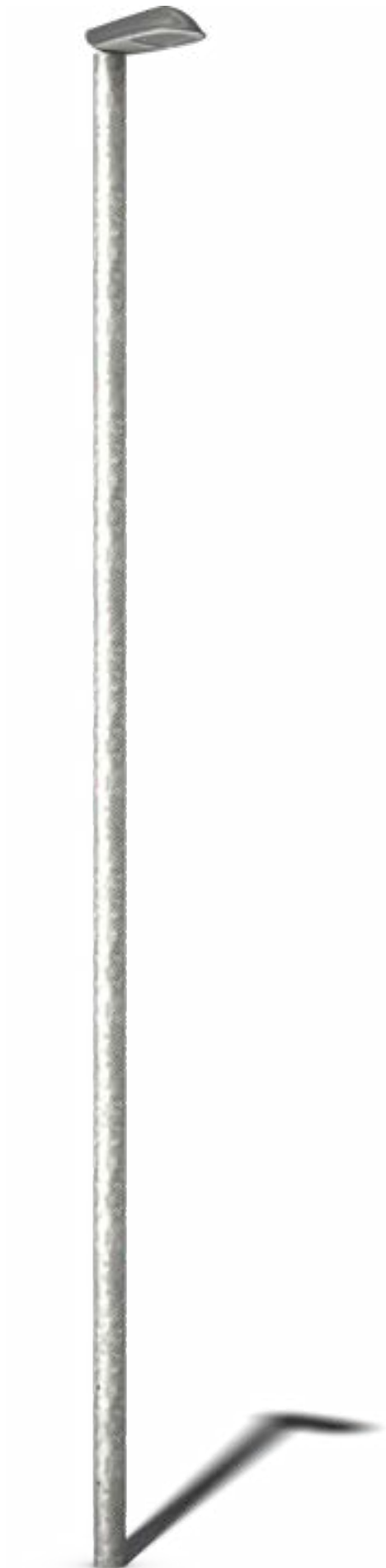

Description

Parallel steel columns are perfect for post top applications as well as bracket mounted configurations. Demountable or integral bracket arm arrangements can be selected to best suit the application.

Specifications

Valmont Stainton manufactures a wide range of parallel steel lighting columns from 3 to 12 metres.

Valmont Stainton operates a Quality Assurance system which complies with requirements of BS EN ISO 9001.

Our welders and welding procedures are independently certified in accordance with 288EN ISO 9606 and EN ISO 15607.

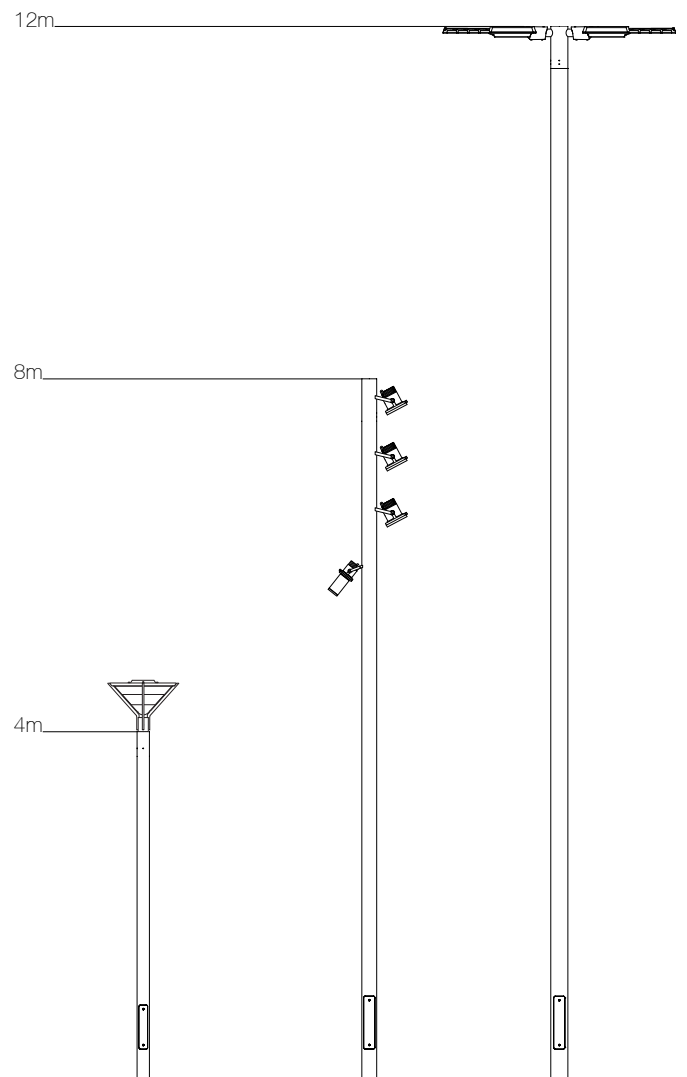



Dimensional Information

Planted Root Option

| Height (m) | BD (mm) | TD (mm) | PD (mm) | DH x DW (mm) | Mass (kg) | OTM (kNm) | Shear (kN) | Min. Concrete Dia. (mm) |
|------------|---------|---------|---------|--------------|-----------|-----------|------------|-------------------------|
| 3 | 139,7 | 139,7 | 800 | 500 x 100 | 39 | 5,52 | 1,97 | 580 |
| 4 | 139,7 | 139,7 | 800 | 500 x 100 | 51 | 5,34 | 1,53 | 539 |
| 5 | 139,7 | 139,7 | 800 | 500 x 100 | 61 | 5,24 | 1,32 | 516 |
| 6 | 139,7 | 139,7 | 1000 | 500 x 100 | 81 | 7,61 | 1,53 | 385 |
| 7 | 139,7 | 139,7 | 1200 | 500 x 100 | 94 | 7,61 | 1,48 | 224 |
| 8 | 168,3 | 168,3 | 1200 | 600 x 115 | 155 | 24,11 | 3,52 | 699 |
| 10 | 168,3 | 168,3 | 1500 | 600 x 115 | 195 | 23,92 | 2,92 | 355 |
| 12 | 193,7 | 193,7 | 1700 | 600 x 115 | 265 | 36,76 | 4,02 | 373 |

Flange Plated Option

| Height (m) | BD (mm) | TD (mm) | DH x DW (mm) | SL x T x BC (mm) | Anchor Bolts | Mass (kg) | OTM (kNm) | Shear (kN) | Concrete Foundation Sizes (mm) |
|------------|---------|---------|--------------|------------------|--------------|-----------|-----------|------------|--------------------------------|
| 3 | 139,7 | 139,7 | 500 x 100 | 260 x 15 x 200 | M18 x 400 | 36 | 5,52 | 1,97 | 400 sq x 700 h |
| 4 | 139,7 | 139,7 | 500 x 100 | 260 x 15 x 200 | M18 x 400 | 48 | 5,34 | 1,53 | 400 sq x 700 h |
| 5 | 139,7 | 139,7 | 500 x 100 | 260 x 15 x 200 | M18 x 400 | 58 | 5,24 | 1,32 | 400 sq x 700 h |
| 6 | 139,7 | 139,7 | 500 x 100 | 260 x 15 x 200 | M18 x 400 | 74 | 7,61 | 1,53 | 400 sq x 800 h |
| 7 | 139,7 | 139,7 | 500 x 100 | 260 x 15 x 200 | M18 x 400 | 84 | 7,61 | 1,48 | 400 sq x 800 h |
| 8 | 168,3 | 168,3 | 600 x 115 | 420 x 20 x 300 | M24 x 820 | 158 | 24,11 | 3,52 | 700 sq x 1200 h |
| 10 | 168,3 | 168,3 | 600 x 115 | 420 x 20 x 300 | M24 x 820 | 193 | 23,92 | 2,92 | 700 sq x 1200 h |
| 12 | 193,7 | 193,7 | 600 x 115 | 420 x 20 x 300 | M24 x 820 | 257 | 36,76 | 4,02 | 800 sq x 1400 h |

Headload Capacity Information

| Height (m) | Mounting Arrangement | Projection (m) | Weight (kg) | Extra Light | Light | Medium | Heavy | Extra Heavy |
|------------|----------------------|----------------|-------------|-------------|-------|--------|-------|-------------|
| 3 | Post Top | N/A | 50 | 1,80 | 1,58 | 1,46 | 1,34 | 1,08 |
| | Single Arm | 0,5 | 15 | 0,76 | 0,65 | 0,60 | 0,55 | 0,44 |
| | Double Arm | 0,5 | 15 | 1,00 | 0,87 | 0,80 | 0,73 | 0,58 |
| 4 | Post Top | N/A | 50 | 1,18 | 1,03 | 0,94 | 0,86 | 0,70 |
| | Single Arm | 0,5 | 15 | 0,57 | 0,50 | 0,45 | 0,42 | 0,32 |
| | Double Arm | 0,5 | 15 | 0,62 | 0,53 | 0,49 | 0,44 | 0,35 |
| 5 | Post Top | N/A | 50 | 0,78 | 0,69 | 0,63 | 0,57 | 0,45 |
| | Single Arm | 0,5 | 15 | 0,42 | 0,36 | 0,32 | 0,30 | 0,23 |
| | Double Arm | 0,5 | 15 | 0,38 | 0,32 | 0,29 | 0,26 | 0,19 |
| 6 | Post Top | N/A | 30 | 0,98 | 0,85 | 0,78 | 0,71 | 0,57 |
| | Single Arm | 0,5 | 15 | 0,57 | 0,49 | 0,44 | 0,41 | 0,31 |
| | Double Arm | 0,5 | 15 | 0,30 | 0,24 | 0,22 | 0,19 | 0,15 |
| 7 | Post Top | N/A | 30 | 0,69 | 0,59 | 0,53 | 0,49 | 0,39 |
| | Single Arm | 1,0 | 15 | 0,30 | 0,24 | 0,22 | 0,19 | 0,14 |
| | Double Arm | 1,0 | 15 | 0,25 | 0,21 | 0,18 | 0,16 | 0,10 |
| 8 | Post Top | N/A | 30 | 2,03 | 1,78 | 1,62 | 1,47 | 1,13 |
| | Single Arm | 1,0 | 15 | 1,30 | 1,12 | 1,01 | 0,91 | 0,69 |
| | Double Arm | 1,0 | 15 | 0,98 | 0,84 | 0,76 | 0,67 | 0,50 |
| 10 | Post Top | N/A | 40 | 1,25 | 1,06 | 0,96 | 0,85 | 0,60 |
| | Single Arm | 1,0 | 15 | 0,85 | 0,71 | 0,64 | 0,56 | 0,38 |
| | Double Arm | 1,0 | 15 | 0,56 | 0,46 | 0,41 | 0,36 | 0,23 |
| 12 | Post Top | N/A | 40 | 1,48 | 1,25 | 1,11 | 0,97 | 0,67 |
| | Single Arm | 1,0 | 15 | 1,11 | 0,90 | 0,78 | 0,66 | 0,39 |
| | Double Arm | 1,0 | 15 | 0,49 | 0,38 | 0,32 | 0,26 | 0,14 |

Dimensions and technical information given as an indication.

See diagrams beginning on page 308 for info regarding the moments and abbreviations used in above tables.

Valmont reserves the right to make, without delay and without prior notice, the technical or aesthetic modifications that it deems necessary to improve the products of the Standard Collection.

Octagonal Steel Light Duty

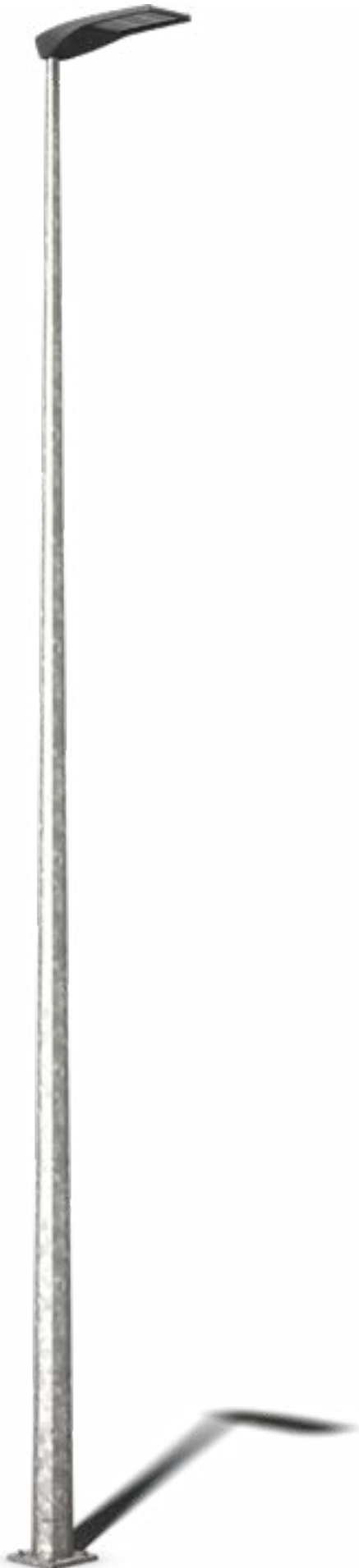

Description

In 1978, Valmont Stainton manufactured its first Octagonal Steel Lighting Column. Since then we have established this design as the nation's favourite motorway column and have supplied these on almost every major motorway in the UK.

Specifications

Light Duty octagonal steel lighting columns are available in mounting heights from 4 to 15 metres.

They can be used for post top applications or supplied with demountable or integral bracket arm arrangements.

Valmont Stainton operates a Quality Assurance system which complies with requirements of BS EN ISO 9001.

Our welders and welding procedures are independently certified in accordance with EN ISO 9606 and EN ISO 15607.

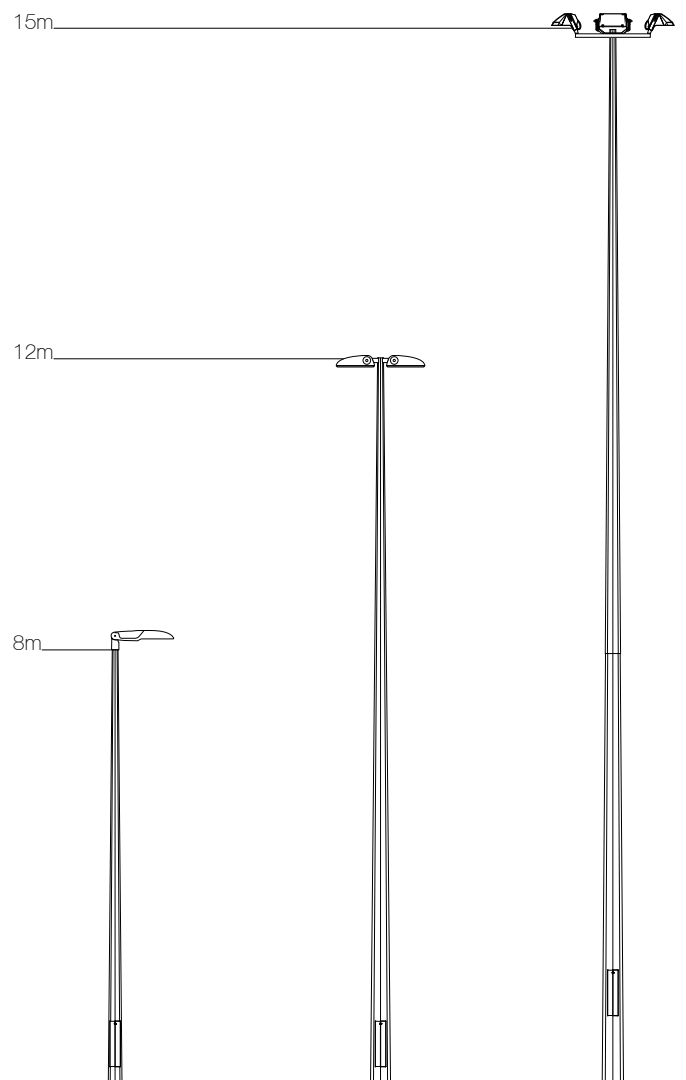



Dimensional Information

Planted Root Option

| Height (m) | BD (mm) | TD (mm) | PD (mm) | DH x DW (mm) | Mass (kg) | OTM (kNm) | Shear (kN) | Min. Concrete Dia. (mm) |
|------------|---------|---------|---------|--------------|-----------|-----------|------------|-------------------------|
| 4 | 165 | 74 | 800 | 500 x 100 | 32 | 3,94 | 1,38 | 477 |
| 5 | 165 | 74 | 800 | 500 x 100 | 40 | 4,08 | 1,23 | 482 |
| 6 | 165 | 74 | 1000 | 500 x 100 | 48 | 4,04 | 1,36 | 245 |
| 8 | 195 | 76 | 1200 | 600 x 115 | 78 | 12,49 | 2,75 | 435 |
| 10 | 233 | 76 | 1500 | 600 x 115 | 122 | 21,54 | 3,90 | 385 |
| 12 | 285 | 76 | 1700 | 600 x 115 | 171 | 36,04 | 5,77 | 440 |
| 15 | 300 | 76 | 2000 | 600 x 115 | 263 | 42,68 | 5,55 | 320 |

Flange Plated Option

| Height (m) | BD (mm) | TD (mm) | DH x DW (mm) | SL x T x BC (mm) | Anchor Bolts | Mass (kg) | OTM (kNm) | Shear (kN) | Concrete Foundation Size (mm) |
|------------|---------|---------|--------------|------------------|--------------|-----------|-----------|------------|-------------------------------|
| 4 | 150 | 74 | 500 x 100 | 260 x 15 x 200 | M18 x 400 | 32 | 3,94 | 1,38 | 400 sq x 600 h |
| 5 | 152 | 74 | 500 x 100 | 260 x 15 x 200 | M18 x 400 | 40 | 4,08 | 1,23 | 400 sq x 600 h |
| 6 | 152 | 74 | 500 x 100 | 260 x 15 x 200 | M18 x 400 | 48 | 4,04 | 1,36 | 400 sq x 600 h |
| 8 | 176 | 76 | 600 x 115 | 420 x 25 x 300 | M24 x 820 | 93 | 12,49 | 2,75 | 500 sq x 1000 h |
| 10 | 209 | 76 | 600 x 115 | 420 x 25 x 300 | M24 x 820 | 131 | 21,54 | 3,90 | 600 sq x 1200 h |
| 12 | 255 | 76 | 600 x 115 | 420 x 30 x 300 | M24 x 820 | 180 | 36,04 | 5,77 | 800 sq x 1500 h |
| 15 | 270 | 76 | 600 x 115 | 440 x 35 x 300 | M30 x 1070 | 260 | 42,68 | 5,55 | 800 sq x 1600 h |

Headload Capacity Information

| Height (m) | Mounting Arrangement | Projection (m) | Weight (kg) | Extra Light | Light | Medium | Heavy | Extra Heavy |
|------------|----------------------|----------------|-------------|-------------|-------|--------|-------|-------------|
| 4 | Post Top | N/A | 50 | 0,87 | 0,74 | 0,68 | 0,60 | 0,44 |
| | Single Arm | 0,5 | 15 | 0,36 | 0,30 | 0,27 | 0,23 | 0,17 |
| | Double Arm | 0,5 | 15 | 0,39 | 0,33 | 0,30 | 0,27 | 0,19 |
| 5 | Post Top | N/A | 30 | 0,58 | 0,47 | 0,43 | 0,36 | 0,23 |
| | Single Arm | 0,5 | 15 | 0,30 | 0,23 | 0,20 | 0,19 | 0,11 |
| | Double Arm | 0,5 | 15 | 0,25 | 0,20 | 0,17 | 0,14 | 0,07 |
| 6 | Post Top | N/A | 30 | 0,33 | 0,25 | 0,20 | 0,15 | 0,06 |
| | Single Arm | 0,5 | 15 | 0,19 | 0,14 | 0,11 | 0,07 | 0,01 |
| | Double Arm | 0,5 | 15 | 0,12 | 0,09 | 0,06 | 0,04 | 0,00 |
| 8 | Post Top | N/A | 80 | 0,65 | 0,54 | 0,47 | 0,41 | 0,27 |
| | Single Arm | 1 | 15 | 0,47 | 0,39 | 0,35 | 0,30 | 0,19 |
| | Double Arm | 1 | 15 | 0,31 | 0,25 | 0,20 | 0,17 | 0,09 |
| 10 | Post Top | N/A | 100 | 0,76 | 0,62 | 0,54 | 0,46 | 0,28 |
| | Single Arm | 1,5 | 15 | 0,55 | 0,44 | 0,38 | 0,31 | 0,19 |
| | Double Arm | 1,5 | 15 | 0,36 | 0,28 | 0,23 | 0,19 | 0,09 |
| 12 | Post Top | N/A | 100 | 0,87 | 0,76 | 0,69 | 0,63 | 0,38 |
| | Single Arm | 1,5 | 15 | 0,55 | 0,47 | 0,43 | 0,39 | 0,30 |
| | Double Arm | 1,5 | 15 | 0,44 | 0,38 | 0,35 | 0,30 | 0,15 |
| 15 | Post Top | N/A | 100 | 0,58 | 0,39 | 0,30 | 0,19 | 0,00 |
| | Single Arm | 2 | 18 | 0,52 | 0,36 | 0,27 | 0,17 | 0,00 |
| | Double Arm | 2 | 18 | 0,22 | 0,12 | 0,06 | 0,00 | 0,00 |

Dimensions and technical information given as an indication.

See diagrams beginning on page 308 for info regarding the moments and abbreviations used in above tables.

Valmont reserves the right to make, without delay and without prior notice, the technical or aesthetic modifications that it deems necessary to improve the products of the Standard Collection.

Octagonal Steel Heavy Duty



Description

In 1978, Valmont Stainton manufactured its first Octagonal Steel Lighting Column. Since then we have established this design as the nation's favourite motorway column and have supplied these on almost every major motorway in the UK.

Specifications

Heavy Duty octagonal steel lighting columns are available in mounting heights from 8 to 20 metres.

They can be used for post top applications or supplied with demountable or integral bracket arm arrangements.

Valmont Stainton operates a Quality Assurance system which complies with requirements of BS EN ISO 9001.

Our welders and welding procedures are independently certified in accordance with EN ISO 9606 and EN ISO 15607.

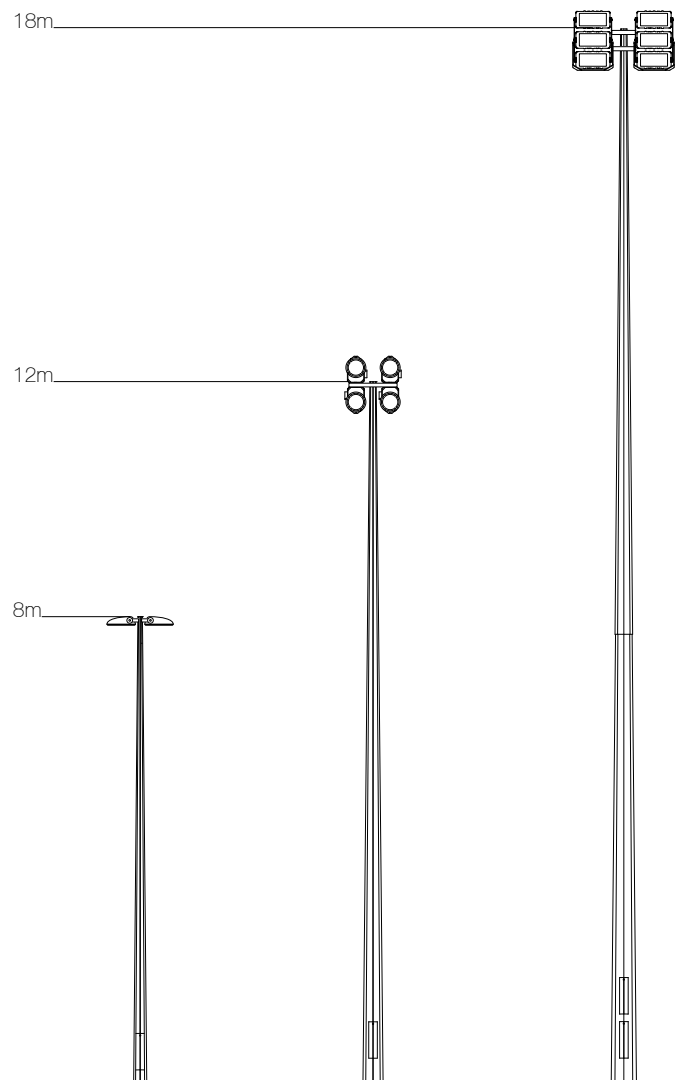



Dimensional Information

Planted Root Option

| Height (m) | BD (mm) | TD (mm) | PD (mm) | DH x DW (mm) | Mass (kg) | OTM (kNm) | Shear (kN) | Min. Concrete Dia. (mm) |
|------------|---------|---------|---------|--------------|-----------|-----------|------------|-------------------------|
| 8 | 233 | 76 | 1500 | 600 x 115 | 122 | 21,7 | 4,18 | 400 |
| 10 | 285 | 76 | 1700 | 600 x 115 | 171 | 35,96 | 5,89 | 450 |
| 12 | 350 | 102 | 1700 | 600 x 135 | 335 | 100,83 | 11,87 | 1230 |
| 15 | 350 | 102 | 2000 | 600 x 135 | 425 | 100,7 | 11,35 | 750 |
| 18 | 432 | 102 | 2000 | 600 x 135 | 592 | 144,1 | 14,88 | 1060 |
| *20 | 432 | 102 | 2000 | 600 x 135 | 761 | 205,7 | 18,03 | 1500 |

* = Extra Heavy Duty Option.

Flange Plated Option

| Height (m) | BD (mm) | TD (mm) | DH x DW (mm) | SL x T x BC (mm) | Anchor Bolts | Mass (kg) | OTM (kNm) | Shear (kN) | Concrete Foundation Size (mm) |
|------------|---------|---------|--------------|------------------|----------------|-----------|-----------|------------|-------------------------------|
| 8 | 209 | 76 | 600 x 115 | 420 x 25 x 300 | 8 x M24 x 820 | 118 | 21,7 | 4,18 | 700 sq x 1200 h |
| 10 | 255 | 76 | 600 x 115 | 420 x 30 x 300 | 8 x M24 x 820 | 133 | 35,96 | 5,89 | 800 sq x 1500 h |
| 12 | 350 | 102 | 600 x 135 | 530 x 30 x 450 | 8 x M24 x 820 | 335 | 100,83 | 11,87 | 1700 sq x 1600 h |
| 15 | 350 | 102 | 600 x 135 | 530 x 30 x 450 | 8 x M24 x 820 | 425 | 100,7 | 11,35 | 2000 sq x 1100 h |
| 18 | 432 | 102 | 600 x 135 | 620 x 30 x 520 | 12 x M24 x 820 | 592 | 144,1 | 14,88 | 2200 sq x 1300 h |
| *20 | 432 | 102 | 600 x 135 | 670 x 35 x 570 | 12 x M24 x 820 | 745 | 205,7 | 18,03 | 2400 sq x 1500 h |

* = Extra Heavy Duty Option.

Headload Capacity Information

| Height (m) | Mounting Arrangement | Projection (m) | Weight (kg) | Extra Light | Light | Medium | Heavy | Extra Heavy |
|------------|----------------------|----------------|-------------|-------------|-------|--------|-------|-------------|
| 8 | Post Top | N/A | 150 | 1,34 | 1,13 | 1,01 | 0,89 | 0,63 |
| 10 | Post Top | N/A | 150 | 1,64 | 1,37 | 1,21 | 1,05 | 0,72 |
| 12 | Post Top | N/A | 300 | 4,21 | 3,58 | 3,23 | 2,88 | 2,13 |
| 15 | Post Top | N/A | 200 | 2,52 | 2,07 | 1,80 | 1,54 | 1,00 |
| 18 | Post Top | N/A | 200 | 2,72 | 2,17 | 1,86 | 1,54 | 0,88 |
| *20 | Post Top | N/A | 200 | 3,51 | 2,98 | 2,62 | 2,23 | 1,39 |

* = Extra Heavy Duty Option.

Dimensions and technical information given as an indication.

See diagrams beginning on page 308 for info regarding the moments and abbreviations used in above tables.

Valmont reserves the right to make, without delay and without prior notice, the technical or aesthetic modifications that it deems necessary to improve the products of the Standard Collection.

SWT Conical Steel Light Duty



Description

Seamless weld technology (SWT) makes Valmont conical steel columns a great starting point for your next decorative lighting project.

Seamless weld technology allows Valmont to produce a column with a nearly invisible weld. The absence of a vertical seam elevates the aesthetic of the column giving it a more modern and contemporary feel.

Specifications

Light Duty SWT columns (12mm taper) are available in mounting heights from 4 to 12 metres.

They can be used for post top applications or supplied with demountable or integral bracket arm arrangements.

Valmont Stainton operates a Quality Assurance system which complies with requirements of BS EN ISO 9001.

Our welders and welding procedures are independently certified in accordance with EN ISO 9606 and EN ISO 15607.

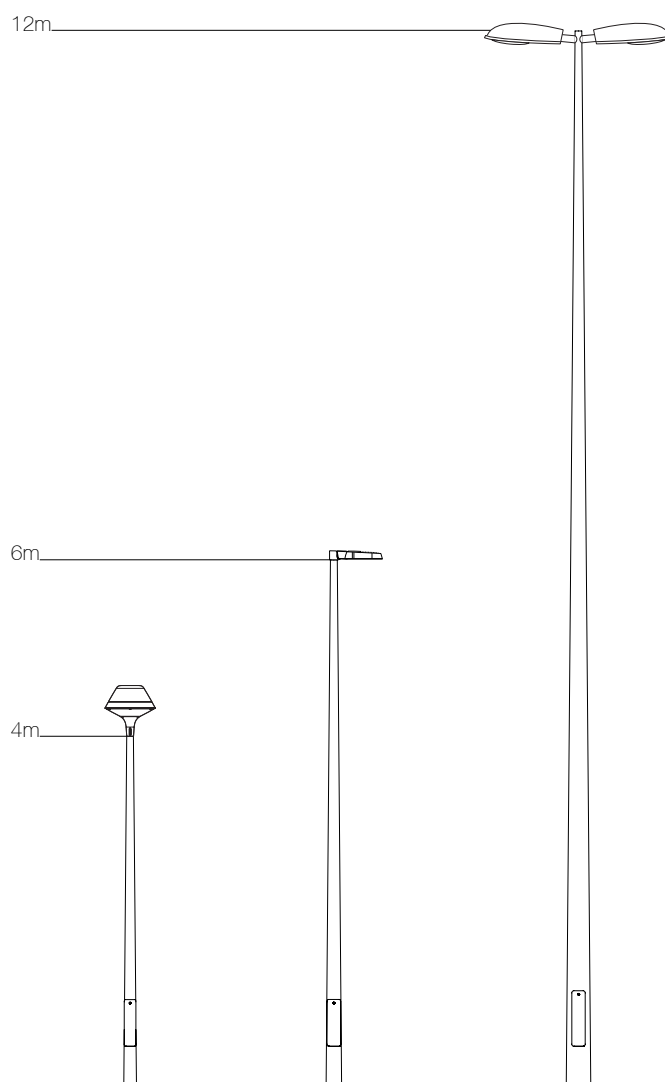



Dimensional Information

Planted Root Option

| Height (m) | BD (mm) | TD (mm) | PD (mm) | DH x DW (mm) | Mass (kg) | OTM (kNm) | Shear (kN) | Min. Concrete Dia. (mm) |
|------------|---------|---------|---------|--------------|-----------|-----------|------------|-------------------------|
| 4 | 146 | 76 | 800 | 500 x 100 | 44 | 3,52 | 1,12 | 426 |
| 5 | 146 | 76 | 800 | 500 x 100 | 49 | 4,70 | 1,24 | 555 |
| 6 | 160 | 76 | 1000 | 500 x 100 | 65 | 6,10 | 1,38 | 372 |
| 8 | 186 | 76 | 1200 | 600 x 115 | 88 | 7,50 | 1,50 | 263 |
| 10 | 214 | 76 | 1500 | 600 x 115 | 174 | 16,01 | 2,34 | 285 |
| 12 | 240 | 76 | 1700 | 600 x 115 | 220 | 21,30 | 2,85 | 260 |

* The 4m column is top Ø89mm with a Ø76mm spigot as standard.

Flange Plated Option

| Height (m) | BD (mm) | TD (mm) | DH x DW (mm) | SL x T x BC (mm) | Anchor Bolts | Mass (kg) | OTM (kNm) | Shear (kN) | Concrete Foundation Size (mm) |
|------------|---------|---------|--------------|------------------|--------------|-----------|-----------|------------|-------------------------------|
| 4 | 136 | 76 | 500 x 100 | 260 x 15 x 200 | M18 x 400 | 44 | 3,52 | 1,12 | 400 sq x 500 h |
| 5 | 136 | 76 | 500 x 100 | 260 x 15 x 200 | M18 x 400 | 49 | 4,70 | 1,24 | 400 sq x 800 h |
| 6 | 148 | 76 | 500 x 100 | 260 x 15 x 200 | M18 x 400 | 65 | 6,10 | 1,38 | 400 sq x 800 h |
| 8 | 172 | 76 | 600 x 115 | 420 x 20 x 300 | M24 x 820 | 88 | 7,50 | 1,50 | 400 sq x 500 h |
| 10 | 196 | 76 | 600 x 115 | 420 x 20 x 300 | M24 x 820 | 174 | 16,01 | 2,34 | 600 sq x 1000 h |
| 12 | 220 | 76 | 600 x 115 | 420 x 20 x 300 | M24 x 820 | 220 | 21,30 | 2,85 | 600 sq x 1200 h |

* The 4m column is top Ø89mm with a Ø76mm spigot as standard.

Headload Capacity Information

| Height (m) | Mounting Arrangement | Projection (m) | Weight (kg) | Extra Light | Light | Medium | Heavy | Extra Heavy |
|------------|----------------------|----------------|-------------|-------------|-------|--------|-------|-------------|
| 4 | Post Top | N/A | 30 | 0,80 | 0,69 | 0,63 | 0,57 | 0,45 |
| | Single Arm | 0,5 | 15 | 0,41 | 0,35 | 0,32 | 0,29 | 0,22 |
| | Double Arm | 0,5 | 15 | 0,50 | 0,43 | 0,39 | 0,35 | 0,27 |
| 5 | Post Top | N/A | 30 | 0,56 | 0,48 | 0,43 | 0,40 | 0,30 |
| | Single Arm | 0,5 | 15 | 0,32 | 0,26 | 0,23 | 0,21 | 0,16 |
| | Double Arm | 0,5 | 15 | 0,31 | 0,25 | 0,22 | 0,21 | 0,14 |
| 6 | Post Top | N/A | 30 | 0,64 | 0,54 | 0,48 | 0,43 | 0,33 |
| | Single Arm | 0,5 | 15 | 0,41 | 0,34 | 0,30 | 0,27 | 0,20 |
| | Double Arm | 0,5 | 15 | 0,32 | 0,26 | 0,23 | 0,21 | 0,15 |
| 8 | Post Top | N/A | 30 | 0,31 | 0,25 | 0,22 | 0,19 | 0,13 |
| | Single Arm | 1 | 15 | 0,12 | 0,08 | 0,07 | 0,05 | 0,02 |
| | Double Arm | 1 | 15 | 0,08 | 0,05 | 0,03 | 0,02 | 0,00 |
| 10 | Post Top | N/A | 30 | 0,66 | 0,56 | 0,50 | 0,45 | 0,35 |
| | Single Arm | 1 | 15 | 0,38 | 0,31 | 0,28 | 0,24 | 0,17 |
| | Double Arm | 1 | 15 | 0,25 | 0,21 | 0,18 | 0,15 | 0,10 |
| 12 | Post Top | N/A | 30 | 0,65 | 0,55 | 0,50 | 0,44 | 0,33 |
| | Single Arm | 1 | 15 | 0,42 | 0,35 | 0,30 | 0,26 | 0,18 |
| | Double Arm | 1 | 15 | 0,24 | 0,20 | 0,17 | 0,14 | 0,08 |

Dimensions and technical information given as an indication.

See diagrams beginning on page 308 for info regarding the moments and abbreviations used in above tables.

Valmont reserves the right to make, without delay and without prior notice, the technical or aesthetic modifications that it deems necessary to improve the products of the Standard Collection.

SWT Conical Steel Heavy Duty

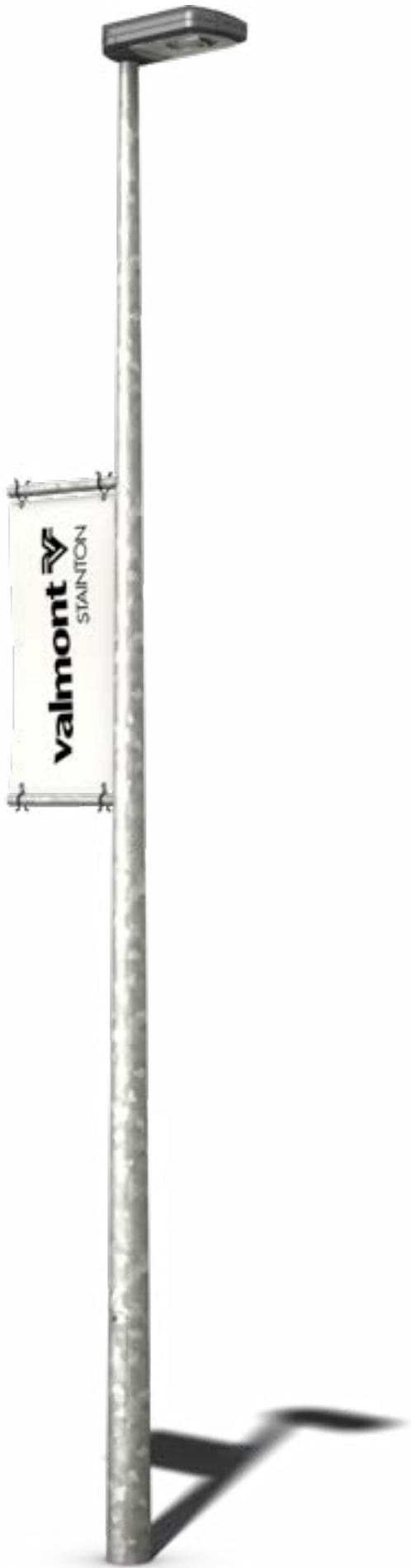

Description

Seamless weld technology (SWT) makes Valmont conical steel columns a great starting point for your next decorative lighting project.

Seamless weld technology allows Valmont to produce a column with a nearly invisible weld. The absence of a vertical seam elevates the aesthetic of the column giving it a more modern and contemporary feel.

Specifications

Heavy Duty SWT columns (17mm taper) are available in mounting heights from 4 to 12 metres.

They can be used for post top applications or supplied with demountable or integral bracket arm arrangements.

Valmont Stainton operates a Quality Assurance system which complies with requirements of BS EN ISO 9001.

Our welders and welding procedures are independently certified in accordance with EN ISO 9606 and EN ISO 15607.

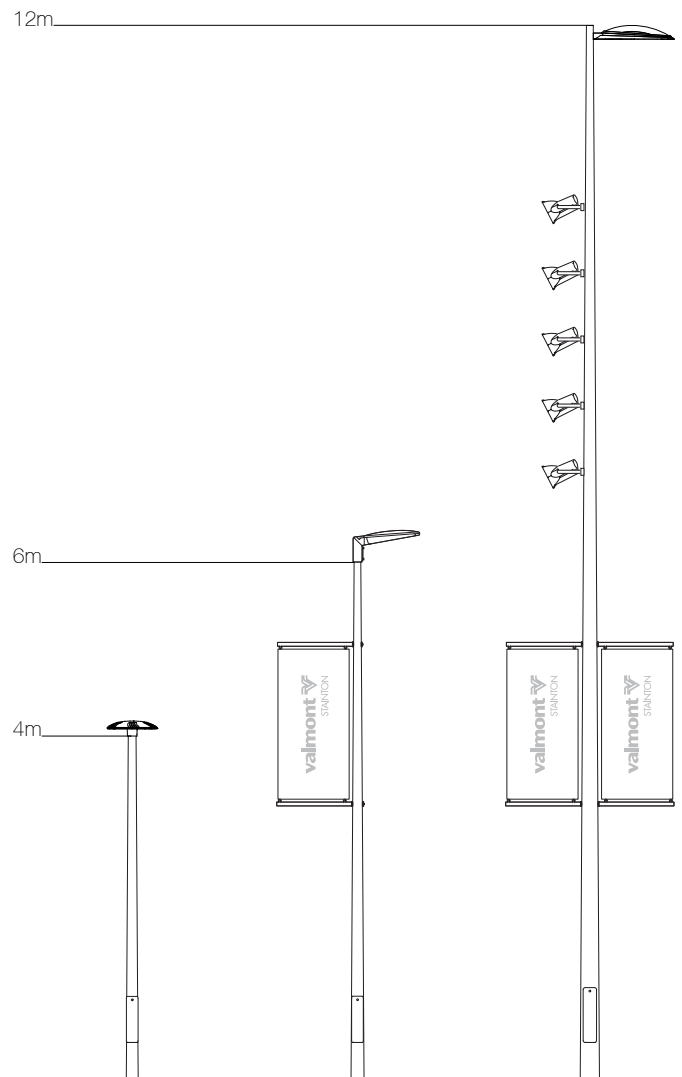



Dimensional Information

Planted Root Option

| Height (m) | BD (mm) | TD (mm) | PD (mm) | DH x DW (mm) | Mass (kg) | OTM (kNm) | Shear (kN) | Min. Concrete Dia. (mm) |
|------------|---------|---------|---------|--------------|-----------|-----------|------------|-------------------------|
| 4 | 157 | 76 | 800 | 500 x 100 | 46 | 3,65 | 1,15 | 442 |
| 5 | 175 | 76 | 800 | 500 x 100 | 56 | 7,20 | 1,70 | 852 |
| 6 | 195 | 76 | 1000 | 500 x 100 | 73 | 9,37 | 1,90 | 569 |
| 8 | 232 | 76 | 1200 | 600 x 115 | 110 | 12,37 | 2,12 | 430 |
| 10 | 272 | 76 | 1500 | 600 x 115 | 204 | 26,60 | 3,49 | 474 |
| 12 | 309 | 76 | 1700 | 600 x 115 | 270 | 43,90 | 4,96 | 535 |

Flange Plated Option

| Height (m) | BD (mm) | TD (mm) | DH x DW (mm) | SL x T x BC (mm) | Anchor Bolts | Mass (kg) | OTM (kNm) | Shear (kN) | Concrete Foundation Size (mm) |
|------------|---------|---------|--------------|------------------|--------------|-----------|-----------|------------|-------------------------------|
| 4 | 144 | 76 | 500 x 100 | 260 x 15 x 200 | M18 x 400 | 49 | 3,65 | 1,15 | 400 sq x 500 h |
| 5 | 161 | 76 | 500 x 100 | 260 x 15 x 200 | M18 x 400 | 52 | 7,20 | 1,70 | 400 sq x 800 h |
| 6 | 178 | 76 | 500 x 100 | 260 x 15 x 200 | M18 x 400 | 73 | 9,37 | 1,90 | 500 sq x 800 h |
| 8 | 212 | 76 | 600 x 115 | 420 x 20 x 300 | M24 x 820 | 114 | 12,37 | 2,12 | 500 sq x 1000 h |
| 10 | 246 | 76 | 600 x 115 | 420 x 20 x 300 | M24 x 820 | 186 | 26,60 | 3,49 | 700 sq x 1300 h |
| 12 | 280 | 76 | 600 x 115 | 420 x 20 x 300 | M24 x 820 | 240 | 43,90 | 4,96 | 800 sq x 1500 h |

Headload Capacity Information

| Height (m) | Mounting Arrangement | Projection (m) | Weight (kg) | Extra Light | Light | Medium | Heavy | Extra Heavy |
|------------|----------------------|----------------|-------------|-------------|-------|--------|-------|-------------|
| 4 | Post Top | N/A | 30 | 0,84 | 0,73 | 0,67 | 0,61 | 0,48 |
| | Single Arm | 0,5 | 15 | 0,70 | 0,60 | 0,54 | 0,49 | 0,38 |
| | Double Arm | 0,5 | 15 | 0,61 | 0,52 | 0,47 | 0,42 | 0,33 |
| 5 | Post Top | N/A | 30 | 1,13 | 0,99 | 0,90 | 0,82 | 0,64 |
| | Single Arm | 0,5 | 15 | 0,72 | 0,63 | 0,57 | 0,51 | 0,40 |
| | Double Arm | 0,5 | 15 | 0,62 | 0,53 | 0,48 | 0,43 | 0,33 |
| 6 | Post Top | N/A | 30 | 1,27 | 1,10 | 1,01 | 0,92 | 0,72 |
| | Single Arm | 0,5 | 15 | 0,90 | 0,78 | 0,70 | 0,63 | 0,50 |
| | Double Arm | 0,5 | 15 | 0,65 | 0,59 | 0,54 | 0,48 | 0,37 |
| 8 | Post Top | N/A | 30 | 0,82 | 0,71 | 0,64 | 0,59 | 0,46 |
| | Single Arm | 1 | 15 | 0,47 | 0,39 | 0,35 | 0,31 | 0,22 |
| | Double Arm | 1 | 15 | 0,33 | 0,28 | 0,24 | 0,21 | 0,15 |
| 10 | Post Top | N/A | 30 | 1,56 | 1,36 | 1,24 | 1,13 | 0,88 |
| | Single Arm | 1 | 15 | 1,07 | 0,93 | 0,84 | 0,76 | 0,58 |
| | Double Arm | 1 | 15 | 0,70 | 0,60 | 0,54 | 0,48 | 0,36 |
| 12 | Post Top | N/A | 30 | 2,21 | 1,92 | 1,76 | 1,59 | 1,23 |
| | Single Arm | 1 | 15 | 1,62 | 1,43 | 1,32 | 1,21 | 0,93 |
| | Double Arm | 1 | 15 | 1,00 | 0,86 | 0,78 | 0,70 | 0,52 |

Dimensions and technical information given as an indication.

See diagrams beginning on page 308 for info regarding the moments and abbreviations used in above tables.

Valmont reserves the right to make, without delay and without prior notice, the technical or aesthetic modifications that it deems necessary to improve the products of the Standard Collection.

Altor Light Duty



Description

Utilising Valmont's Seamless Weld Technology (SWT) specialist sections make our conical columns a great option for large scale area lighting. Altor, is the perfect choice for decorative projects with above average height requirements.

Specifications

The Altor Light Duty range of conical steel shafts are available in heights between 12 and 20 metres.

The Altor range is designed for multi-application use whilst having a rare circular profile in heights above 12 metres.

Valmont Stainton operates a Quality Assurance system which complies with requirements of BS EN ISO 9001.

Our welders and welding procedures are independently certified in accordance with EN ISO 9606 and EN ISO 15607.

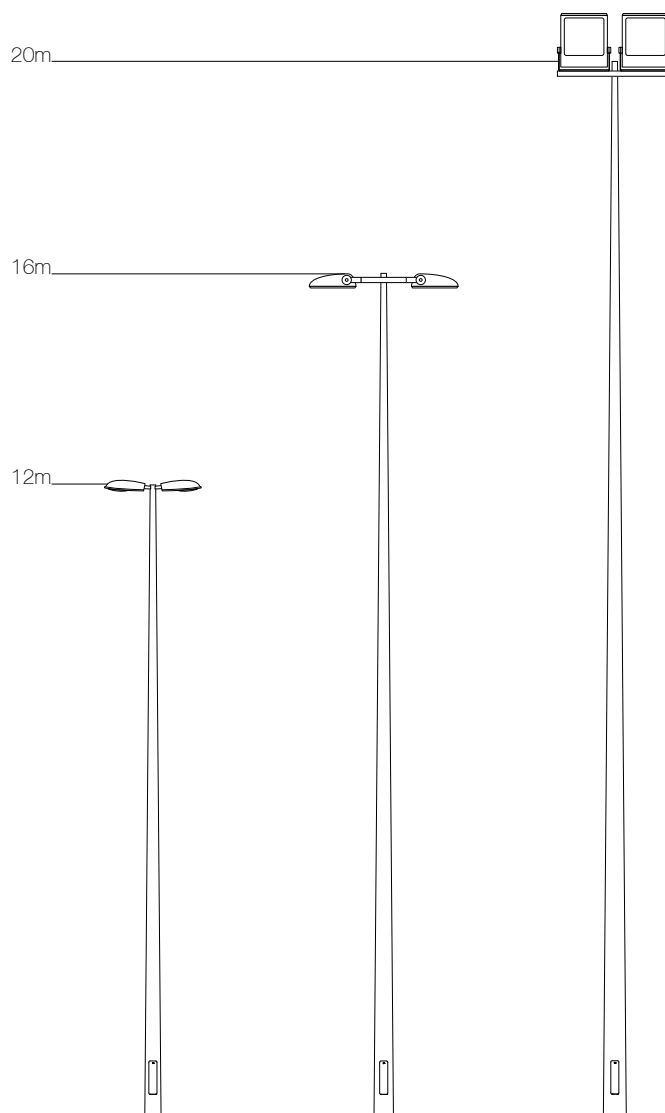



Dimensional Information

Planted Root Option

| Height (m) | BD (mm) | TD (mm) | PD (mm) | DH x DW (mm) | Mass (kg) | OTM (kNm) | Shear (kN) | Min. Concrete Dia. (mm) |
|------------|---------|---------|---------|--------------|-----------|-----------|------------|-------------------------|
| 12 | 268 | 103 | 1700 | 600 x 115 | 258 | 43,02 | 4,56 | 436 |
| 14 | 287 | 103 | 2000 | 600 x 115 | 309 | 49,50 | 4,86 | 309 |
| 16 | 311 | 103 | 2000 | 600 x 115 | 370 | 59,78 | 5,00 | 368 |
| 18 | 335 | 103 | 2000 | 600 x 115 | 421 | 70,15 | 6,14 | 428 |
| 20 | 359 | 103 | 2000 | 600 x 115 | 489 | 80,96 | 6,82 | 491 |

Flange Plated Option

| Height (m) | BD (mm) | TD (mm) | DH x DW (mm) | SL x T x BC (mm) | Anchor Bolts | Mass (kg) | OTM (kNm) | Shear (kN) | Concrete Foundation Size (mm) |
|------------|---------|---------|--------------|------------------|--------------|-----------|-----------|------------|-------------------------------|
| 12 | 247 | 103 | 600 x 115 | 420 x 25 x 300 | M24 x 820 | 239 | 43,02 | 4,56 | 800 sq x 1600 h |
| 14 | 263 | 103 | 600 x 115 | 420 x 25 x 300 | M24 x 820 | 278 | 49,50 | 4,86 | 900 sq x 1700 h |
| 16 | 287 | 103 | 600 x 115 | 420 x 25 x 300 | M24 x 820 | 331 | 59,78 | 5,00 | 900 sq x 1800 h |
| 18 | 311 | 103 | 600 x 115 | 420 x 25 x 300 | M24 x 820 | 376 | 70,15 | 6,14 | 1000 sq x 1900 h |
| 20 | 335 | 103 | 600 x 115 | 530 x 25 x 400 | M24 x 820 | 457 | 80,96 | 6,82 | 1100 sq x 2000 h |

Headload Capacity Information

| Height (m) | Mounting Arrangement | Projection (m) | Weight (kg) | Extra Light | Light | Medium | Heavy | Extra Heavy |
|------------|----------------------|----------------|-------------|-------------|-------|--------|-------|-------------|
| 12 | Post Top | N/A | 200 | 1,64 | 1,42 | 1,28 | 1,17 | 0,89 |
| | Single Arm | 1,5 | 15 | 0,96 | 0,84 | 0,77 | 0,71 | 0,57 |
| | Double Arm | 1,5 | 15 | 0,90 | 0,77 | 0,69 | 0,62 | 0,45 |
| 14 | Post Top | N/A | 200 | 1,38 | 1,19 | 1,09 | 0,97 | 0,72 |
| | Single Arm | 1,5 | 15 | 0,92 | 0,80 | 0,75 | 0,67 | 0,55 |
| | Double Arm | 1,5 | 15 | 0,77 | 0,65 | 0,58 | 0,51 | 0,36 |
| 16 | Post Top | N/A | 200 | 1,30 | 1,11 | 0,99 | 0,87 | 0,62 |
| | Single Arm | 1,5 | 15 | 0,89 | 0,78 | 0,71 | 0,65 | 0,52 |
| | Double Arm | 1,5 | 15 | 0,75 | 0,63 | 0,56 | 0,49 | 0,32 |
| 18 | Post Top | N/A | 200 | 1,03 | 0,89 | 0,82 | 0,74 | 0,54 |
| | Single Arm | 1,5 | 15 | 0,87 | 0,76 | 0,70 | 0,64 | 0,51 |
| | Double Arm | 1,5 | 15 | 0,57 | 0,49 | 0,43 | 0,38 | 0,26 |
| 20 | Post Top | N/A | 200 | 0,93 | 0,80 | 0,72 | 0,64 | 0,44 |
| | Single Arm | 1,5 | 15 | 0,85 | 0,75 | 0,69 | 0,63 | 0,50 |
| | Double Arm | 1,5 | 15 | 0,52 | 0,43 | 0,38 | 0,33 | 0,22 |

Dimensions and technical information given as an indication.

See diagrams beginning on page 308 for info regarding the moments and abbreviations used in above tables.

Valmont reserves the right to make, without delay and without prior notice, the technical or aesthetic modifications that it deems necessary to improve the products of the Standard Collection.



Description

Utilising Valmont's Seamless Weld Technology (SWT) specialist sections make our conical columns a great option for large scale area lighting. Altor, is the perfect choice for decorative projects with above average height requirements.

Specifications

The Altor Heavy Duty range of conical steel shafts are available in heights between 12 and 20 metres.

The Altor range is designed for multi-application use whilst having a rare circular profile in heights above 12 metres.

Valmont Stainton operates a Quality Assurance system which complies with requirements of BS EN ISO 9001.

Our welders and welding procedures are independently certified in accordance with EN ISO 9606 and EN ISO 15607.

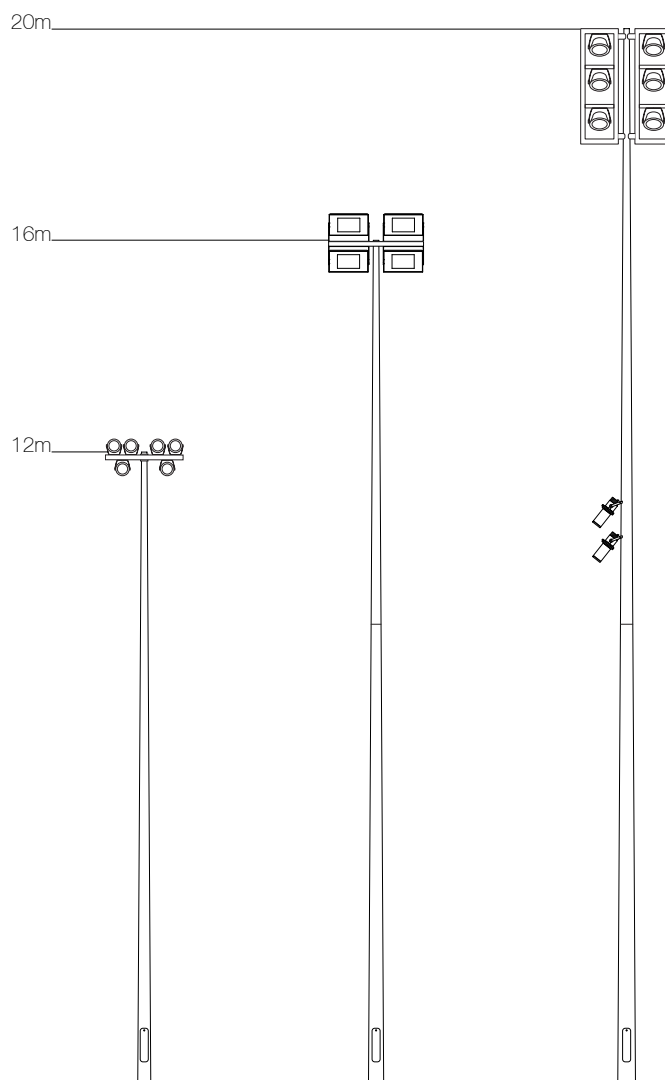



Dimensional Information

Planted Root Option

| Height (m) | BD (mm) | TD (mm) | PD (mm) | DH x DW (mm) | Mass (kg) | OTM (kNm) | Shear (kN) | Min. Concrete Dia. (mm) |
|------------|---------|---------|---------|--------------|-----------|-----------|------------|-------------------------|
| 12 | 336 | 103 | 1700 | 600 x 115 | 306 | 60,64 | 6,21 | 615 |
| 14 | 365 | 103 | 2000 | 600 x 115 | 374 | 70,57 | 6,57 | 440 |
| 16 | 401 | 103 | 2000 | 600 x 115 | 436 | 90,60 | 7,66 | 558 |
| 18 | 435 | 103 | 2000 | 600 x 115 | 517 | 91,84 | 7,68 | 561 |
| 20 | 467 | 103 | 2000 | 600 x 115 | 657 | 123,84 | 8,36 | 751 |

Flange Plated Option

| Height (m) | BD (mm) | TD (mm) | DH x DW (mm) | SL x T x BC (mm) | Anchor Bolts | Mass (kg) | OTM (kNm) | Shear (kN) | Concrete Foundation Size (mm) |
|------------|---------|---------|--------------|------------------|--------------|-----------|-----------|------------|-------------------------------|
| 12 | 307 | 103 | 600 x 115 | 420 x 25 x 300 | M24 x 820 | 271 | 60,64 | 6,21 | 900 sq x 1800 h |
| 14 | 332 | 103 | 600 x 115 | 420 x 25 x 300 | M24 x 820 | 321 | 70,57 | 6,57 | 1000 sq x 1900 h |
| 16 | 368 | 103 | 600 x 115 | 530 x 25 x 400 | M24 x 820 | 410 | 90,60 | 7,66 | 1100 sq x 2100 h |
| 18 | 401 | 103 | 600 x 115 | 530 x 25 x 400 | M24 x 820 | 474 | 91,84 | 7,68 | 1100 sq x 2200 h |
| 20 | 433 | 103 | 600 x 115 | 540 x 25 x 400 | M30 x 1070 | 592 | 123,84 | 8,36 | 2000 sq x 1300 h |

Headload Capacity Information

| Height (m) | Mounting Arrangement | Projection (m) | Weight (kg) | Extra Light | Light | Medium | Heavy | Extra Heavy |
|------------|----------------------|----------------|-------------|-------------|-------|--------|-------|-------------|
| 12 | Post Top | N/A | 300 | 2,94 | 2,57 | 2,36 | 2,14 | 1,66 |
| | Single Arm | 1,5 | 15 | 1,00 | 0,87 | 0,80 | 0,73 | 0,58 |
| | Double Arm | 1,5 | 15 | 1,39 | 1,21 | 1,12 | 1,03 | 0,82 |
| 14 | Post Top | N/A | 300 | 2,22 | 1,97 | 1,79 | 1,62 | 1,21 |
| | Single Arm | 1,5 | 15 | 0,96 | 0,84 | 0,77 | 0,71 | 0,57 |
| | Double Arm | 1,5 | 15 | 1,32 | 1,16 | 1,06 | 0,96 | 0,71 |
| 16 | Post Top | N/A | 300 | 2,14 | 1,87 | 1,73 | 1,58 | 1,26 |
| | Single Arm | 1,5 | 15 | 0,93 | 0,82 | 0,75 | 0,69 | 0,55 |
| | Double Arm | 1,5 | 15 | 1,27 | 1,12 | 1,03 | 0,94 | 0,75 |
| 18 | Post Top | N/A | 300 | 1,66 | 1,44 | 1,30 | 1,17 | 0,80 |
| | Single Arm | 1,5 | 15 | 0,91 | 0,80 | 0,73 | 0,67 | 0,53 |
| | Double Arm | 1,5 | 15 | 1,01 | 0,86 | 0,78 | 0,70 | 0,52 |
| 20 | Post Top | N/A | 300 | 2,36 | 1,99 | 1,75 | 1,54 | 1,05 |
| | Single Arm | 1,5 | 15 | 0,87 | 0,77 | 0,71 | 0,65 | 0,52 |
| | Double Arm | 1,5 | 15 | 1,21 | 1,06 | 0,98 | 0,90 | 0,63 |

Dimensions and technical information given as an indication.

See diagrams beginning on page 308 for info regarding the moments and abbreviations used in above tables.

Valmont reserves the right to make, without delay and without prior notice, the technical or aesthetic modifications that it deems necessary to improve the products of the Standard Collection.

Fluance Single Arm



Description

The Fluance arc is a simple interpretation of the plant theme, and should be thought of as a blade of grass. Symmetry can be created by repeating the same shape down the length of a path or roadway. In contrast, a more random or "natural" look can be created by modulating the columns. This modulation is similar to wind in the grass, and will result in a playful and dynamic installation.

Specifications

100% Steel range, incorporating 30% Recycled Steel. Columns are available from 4.5 to 12 metres.

Fluance columns are constructed from High-Strength S420 Steel using Valmont's Seamless Weld Technology. The columns are then cold formed to create the Fluance Arc.

This range is designed according to standard EN40 part 1 to 6 and has obtained CE marking 1166-CPD-0004.

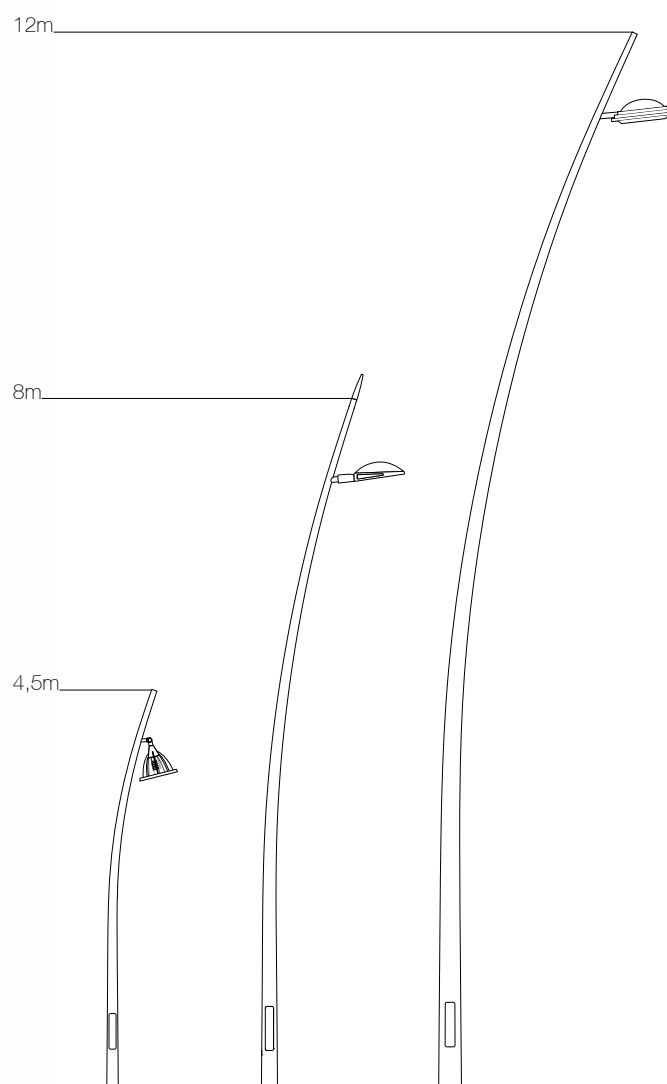



Dimensional Information

Planted Root Option: Supplied with bolt-on root

| Height (m) | BD (mm) | TD (mm) | PD (mm) | DH x DW (mm) | Mass (kg) | OTM (kNm) | Shear (kN) | Min. Concrete Dia. (mm) |
|------------|---------|---------|---------|--------------|-----------|-----------|------------|-------------------------|
| 4,5 | 130 | 60 | 800 | 400 x 75 | 44 | 4,62 | 1,37 | 460 |
| 5 | 138 | 60 | 800 | 400 x 75 | 50 | 5,51 | 1,50 | 543 |
| 6 | 151 | 60 | 1000 | 500 x 85 | 64 | 6,53 | 1,53 | 330 |
| 8 | 183 | 60 | 1200 | 500 x 90 | 98 | 11,07 | 2,01 | 321 |
| 9 | 202 | 60 | 1500 | 500 x 90 | 120 | 13,57 | 2,21 | 204 |
| 10 | 215 | 60 | 1500 | 500 x 90 | 139 | 16,72 | 2,48 | 248 |
| 11 | 238 | 60 | 1700 | 500 x 100 | 170,5 | 20,44 | 2,79 | 209 |
| 12 | 257 | 60 | 1700 | 500 x 105 | 191 | 23,66 | 3,04 | 240 |

Flange Plated Option

| Height (m) | BD (mm) | TD (mm) | DH x DW (mm) | SL x T x BC (mm) | Anchor Bolts | Mass (kg) | OTM (kNm) | Shear (kN) | Concrete Foundation Size (mm) |
|------------|---------|---------|--------------|------------------|--------------|-----------|-----------|------------|-------------------------------|
| 4,5 | 130 | 60 | 400 x 75 | 271 x 4 x 200 | M14/16 x 300 | 38,0 | 4,62 | 1,37 | 400 sq x 600 h |
| 5 | 138 | 60 | 400 x 75 | 271 x 4 x 200 | M14/16 x 300 | 43,0 | 5,51 | 1,50 | 400 sq x 700 h |
| 6 | 151 | 60 | 500 x 85 | 412 x 6 x 300 | M18/20 x 400 | 59,0 | 6,53 | 1,53 | 400 sq x 700 h |
| 8 | 183 | 60 | 500 x 90 | 412 x 6 x 300 | M18/20 x 400 | 87,5 | 11,07 | 2,01 | 500 sq x 900 h |
| 9 | 202 | 60 | 500 x 90 | 412 x 6 x 300 | M18/20 x 400 | 103,0 | 13,57 | 2,21 | 500 sq x 1000 h |
| 10 | 215 | 60 | 500 x 90 | 412 x 6 x 300 | M18/20 x 400 | 120,0 | 16,72 | 2,48 | 600 sq x 1000 h |
| 11 | 238 | 60 | 500 x 100 | 400 x 16 x 300 | M18/20 x 400 | 153,5 | 20,44 | 2,79 | 600 sq x 1100 h |
| 12 | 257 | 60 | 500 x 105 | 400 x 16 x 300 | M18/20 x 400 | 170,0 | 23,66 | 3,04 | 600 sq x 1200 h |

Headload Capacity Information

| Height (m) | Mounting Height (m) | Mounting Arrangement | Projection (m) | Weight (kg) | Extra Light | Light | Medium | Heavy | Extra Heavy |
|------------|---------------------|----------------------|----------------|-------------|-------------|-------|--------|-------|-------------|
| 4,5 | 4,0 | Single Arm | 0,47 | 15 | 1,06 | 0,92 | 0,85 | 0,77 | 0,60 |
| 5 | 4,37 | Single Arm | 0,66 | 15 | 1,17 | 1,01 | 0,92 | 0,84 | 0,65 |
| 6 | 5,27 | Single Arm | 0,45 | 15 | 1,06 | 0,92 | 0,84 | 0,76 | 0,58 |
| 8 | 7 | Single Arm | 0,97 | 15 | 0,96 | 0,82 | 0,75 | 0,66 | 0,51 |
| 9 | 8 | Single Arm | 1,31 | 15 | 0,92 | 0,79 | 0,71 | 0,64 | 0,49 |
| 10 | 9 | Single Arm | 1,47 | 15 | 0,99 | 0,85 | 0,77 | 0,69 | 0,52 |
| 11 | 10 | Single Arm | 1,75 | 15 | 1,01 | 0,86 | 0,78 | 0,70 | 0,52 |
| 12 | 11 | Single Arm | 1,95 | 15 | 1,00 | 0,85 | 0,77 | 0,69 | 0,51 |

Options:

Luminous spike O'light². Information on page 250

Dimensions and technical information given as an indication.

See diagrams beginning on page 308 for info regarding the moments and abbreviations used in above tables.

Valmont reserves the right to make, without delay and without prior notice, the technical or aesthetic modifications that it deems necessary to improve the products of the Standard Collection.

Fluance Double Arm



Description

The Fluance arc is a simple interpretation of the plant theme, and should be thought of as a blade of grass. Symmetry can be created by repeating the same shape down the length of a path or roadway. In contrast, a more random or "natural" look can be created by modulating the columns. This modulation is similar to wind in the grass, and will result in a playful and dynamic installation.

Specifications

100% Steel range, incorporating 30% Recycled Steel. Columns are available from 5 to 9 metres.

Fluance columns are constructed from High-Strength S420 Steel using Valmont's Seamless Weld Technology. The columns are then cold formed to create the Fluance Arc.

This range is designed according to standard EN40 part 1 to 6 and has obtained CE marking 1166-CPD-0004.

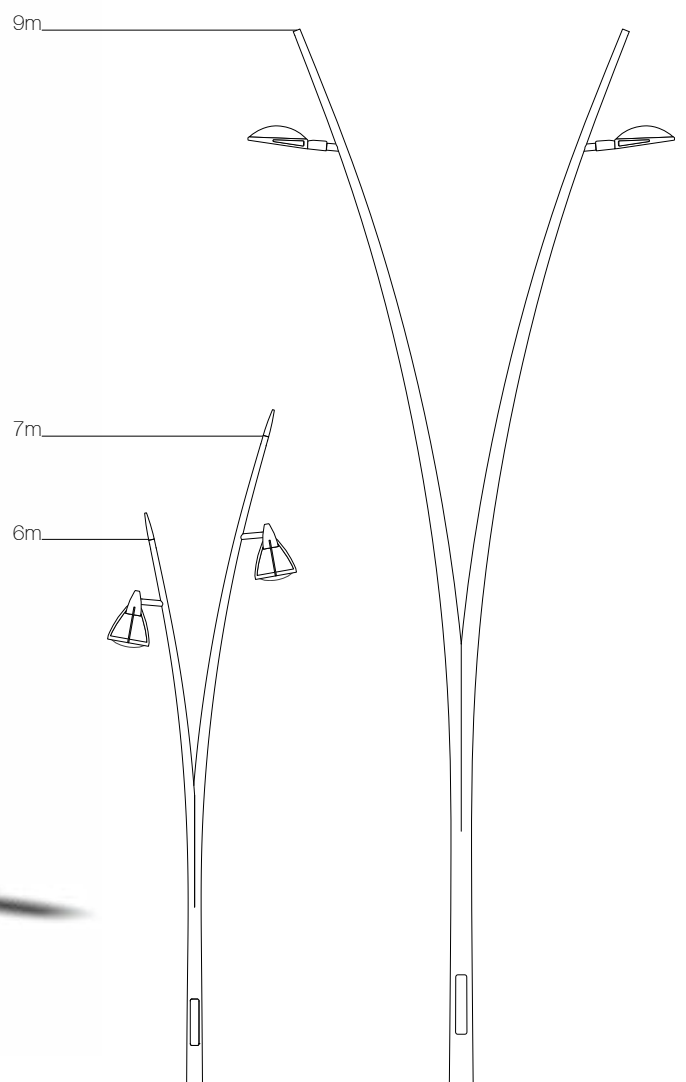



Dimensional Information

Planted Root Option: Supplied with bolt-on root

| Height (m) | BD (mm) | TD (mm) | PD (mm) | DH x DW (mm) | Mass (kg) | OTM (kNm) | Shear (kN) | Min. Concrete Dia. (mm) |
|------------|---------|---------|---------|--------------|-----------|-----------|------------|-------------------------|
| 5 | 138 | 60 | 800 | 400 x 75 | 72,0 | 8,57 | 2,22 | 844 |
| 6 | 151 | 60 | 1000 | 500 x 85 | 93,0 | 9,77 | 2,24 | 495 |
| 7 | 170 | 60 | 1200 | 500 x 90 | 126,0 | 13,61 | 2,76 | 400 |
| 8 | 183 | 60 | 1200 | 500 x 90 | 147,0 | 16,24 | 2,95 | 471 |
| 9 | 202 | 60 | 1500 | 500 x 90 | 184,5 | 17,71 | 2,86 | 266 |

Flange Plated Option

| Height (m) | BD (mm) | TD (mm) | DH x DW (mm) | SL x T x BC (mm) | Anchor Bolts | Mass (kg) | OTM (kNm) | Shear (kN) | Concrete Foundation Size (mm) |
|------------|---------|---------|--------------|------------------|--------------|-----------|-----------|------------|-------------------------------|
| 5 | 138 | 60 | 400 x 75 | 271 x 4 x 200 | M14/16 x 300 | 65,0 | 8,57 | 2,22 | 400 sq x 800 h |
| 6 | 151 | 60 | 500 x 85 | 412 x 6 x 300 | M18/20 x 400 | 88,5 | 9,77 | 2,24 | 500 sq x 800 h |
| 7 | 170 | 60 | 500 x 90 | 412 x 6 x 300 | M18/20 x 400 | 117,0 | 13,61 | 2,76 | 500 sq x 1000 h |
| 8 | 183 | 60 | 500 x 90 | 412 x 6 x 300 | M18/20 x 400 | 136,5 | 16,24 | 2,95 | 600 sq x 1000 h |
| 9 | 202 | 60 | 500 x 90 | 412 x 6 x 300 | M18/20 x 400 | 167,0 | 17,71 | 2,86 | 600 sq x 1100 h |

Headload Capacity Information

| Height (m) | Mounting Height (m) | Mounting Arrangement | Projection (m) | Weight (kg) | Extra Light | Light | Medium | Heavy | Extra Heavy |
|------------|---------------------|----------------------|----------------|-------------|-------------|-------|--------|-------|-------------|
| 5 | 4,37 | Double Arm | 0,66 | 15 | 0,86 | 0,73 | 0,65 | 0,58 | 0,43 |
| 6 | 5,27 | Double Arm | 0,45 | 15 | 0,72 | 0,60 | 0,53 | 0,48 | 0,33 |
| 7 | 6,0 | Double Arm | 0,77 | 15 | 0,86 | 0,72 | 0,64 | 0,57 | 0,42 |
| 8 | 7 | Double Arm | 0,97 | 15 | 0,58 | 0,48 | 0,42 | 0,37 | 0,26 |
| 9 | 8 | Double Arm | 1,31 | 15 | 0,43 | 0,35 | 0,30 | 0,25 | 0,16 |

Options:

Luminous spike O'light[®]. Information on page 250

Dimensions and technical information given as an indication.

See diagrams beginning on page 308 for info regarding the moments and abbreviations used in above tables.

Valmont reserves the right to make, without delay and without prior notice, the technical or aesthetic modifications that it deems necessary to improve the products of the Standard Collection.

CityQuartz



Description

CityQuartz columns are inspired by the Doric columns of ancient Greek architecture. The profile of the column is made of up to 16 flutes. These flutes add depth to the column by playing with light and shadow.

The result is a timeless column that can complement both contemporary and traditional architecture.

Specifications

ASTM A595A Steel column ranging from 3,5 to 9 metres.

The column is manufactured using Electric Resistance Welding. The flutes are made by a cold rolling process.

This range is designed according to standard EN40 part 1 to 6 and has obtained CE marking 1166-CPD-0003.

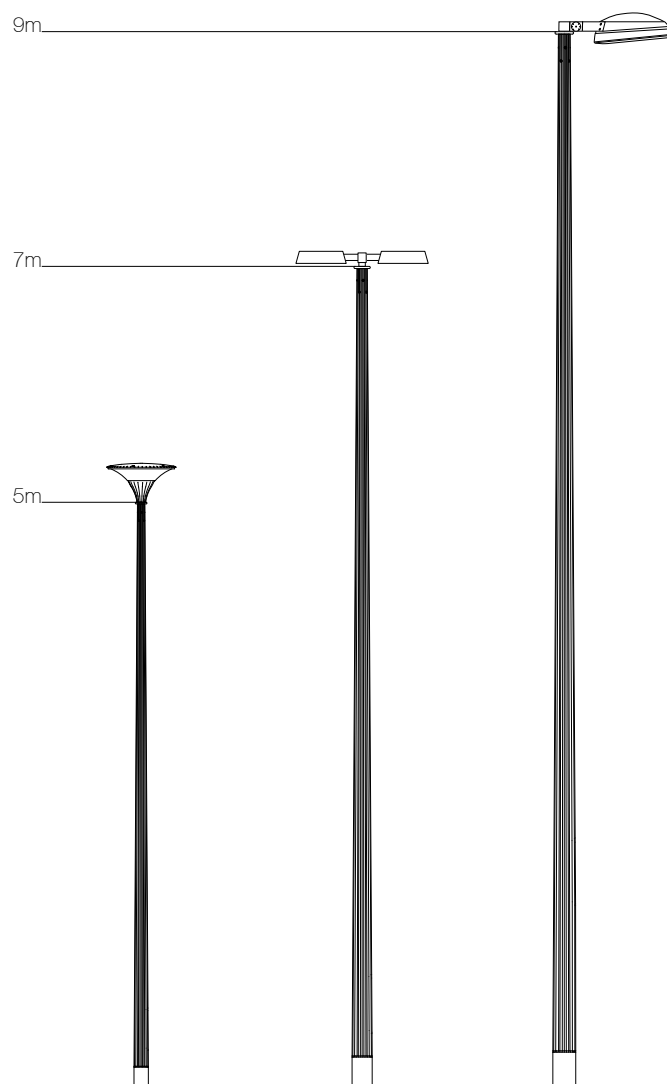
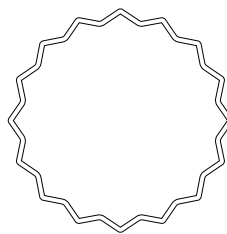



Dimensional Information

Planted Root Option: Supplied with bolt-on root

| Height (m) | BD (mm) | TD (mm) | PD (mm) | DH x DW (mm) | Mass (kg) | OTM (kNm) | Shear (kN) | Min. Concrete Dia. (mm) |
|------------|---------|---------|---------|--------------|-----------|-----------|------------|-------------------------|
| 3,5 | 138 | 89 | 800 | 400 x 80 | 41,0 | 6,30 | 1,95 | 648 |
| 4 | 143 | 89 | 800 | 500 x 90 | 46,5 | 5,97 | 1,75 | 603 |
| 5 | 156 | 89 | 800 | 500 x 92 | 59,0 | 7,63 | 1,95 | 752 |
| 7 | 185 | 89 | 1200 | 500 x 110 | 90,5 | 9,53 | 2,12 | 280 |
| 9 | 211 | 89 | 1500 | 600 x 125 | 190,0 | 20,87 | 3,57 | 313 |

Flange Plated Option

| Height (m) | BD (mm) | TD (mm) | DH x DW (mm) | SL x T x BC (mm) | Anchor Bolts | Mass (kg) | OTM (kNm) | Shear (kN) | Concrete Foundation Size (mm) |
|------------|---------|---------|--------------|------------------|--------------|-----------|-----------|------------|-------------------------------|
| 3,5 | 128 | 89 | 400 x 80 | 271 x 4 x 200 | M14/16 x 300 | 36 | 6,30 | 1,95 | 400 sq x 700 h |
| 4 | 134 | 89 | 500 x 90 | 271 x 4 x 200 | M14/16 x 300 | 41 | 5,97 | 1,75 | 400 sq x 700 h |
| 5 | 147 | 89 | 500 x 92 | 412 x 6 x 300 | M18/20 x 400 | 58 | 7,63 | 1,95 | 400 sq x 800 h |
| 7 | 171 | 89 | 500 x 110 | 400 x 20 x 300 | M18/20 x 400 | 100 | 9,57 | 2,10 | 500 sq x 800 h |
| 9 | 194 | 89 | 600 x 125 | 400 x 20 x 300 | M18/20 x 400 | 184 | 20,87 | 3,57 | 600 sq x 1200 h |

Headload Capacity Information

| Height (m) | Mounting Arrangement | Projection (m) | Weight (kg) | Extra Light | Light | Medium | Heavy | Extra Heavy |
|------------|----------------------|----------------|-------------|-------------|-------|--------|-------|-------------|
| 3,5 | Post Top | N/A | 50 | 1,69 | 1,48 | 1,35 | 1,24 | 0,97 |
| | Post Top Side | N/A | 15 | 1,23 | 1,06 | 0,98 | 0,90 | 0,71 |
| 4 | Post Top | N/A | 50 | 1,31 | 1,13 | 1,04 | 0,93 | 0,72 |
| | Post Top Side | N/A | 15 | 0,92 | 0,80 | 0,73 | 0,67 | 0,52 |
| 5 | Post Top | N/A | 50 | 1,25 | 1,08 | 0,98 | 0,89 | 0,67 |
| | Post Top Side | N/A | 15 | 1,01 | 0,87 | 0,79 | 0,72 | 0,55 |
| 7 | Post Top | N/A | 30 | 0,97 | 0,80 | 0,72 | 0,63 | 0,44 |
| | Post Top Side | N/A | 15 | 0,85 | 0,72 | 0,64 | 0,57 | 0,41 |
| 9 | Post Top | N/A | 40 | 1,13 | 0,94 | 0,84 | 0,73 | 0,51 |
| | Post Top Side | N/A | 15 | 1,01 | 0,85 | 0,76 | 0,66 | 0,48 |

Dimensions and technical information given as an indication.

See diagrams beginning on page 308 for info regarding the moments and abbreviations used in above tables.

Valmont reserves the right to make, without delay and without prior notice, the technical or aesthetic modifications that it deems necessary to improve the products of the Standard Collection.

Shard Contemporary Swage Tubular



Description

A modified version of our standard tubular steel column offering a contemporary twist on a well know design. Shard columns are perfect for post top applications as well as bracket mounted configurations. Demountable or integral bracket arm arrangements can be selected to best suit the application.

Specifications

Valmont Stainton manufactures a wide range of tubular steel lighting columns from 4 to 6 metres.

Valmont Stainton operates a Quality Assurance system which complies with requirements of BS EN ISO 9001.

Our welders and welding procedures are independently certified in accordance with EN ISO 9606 and EN ISO 15607.

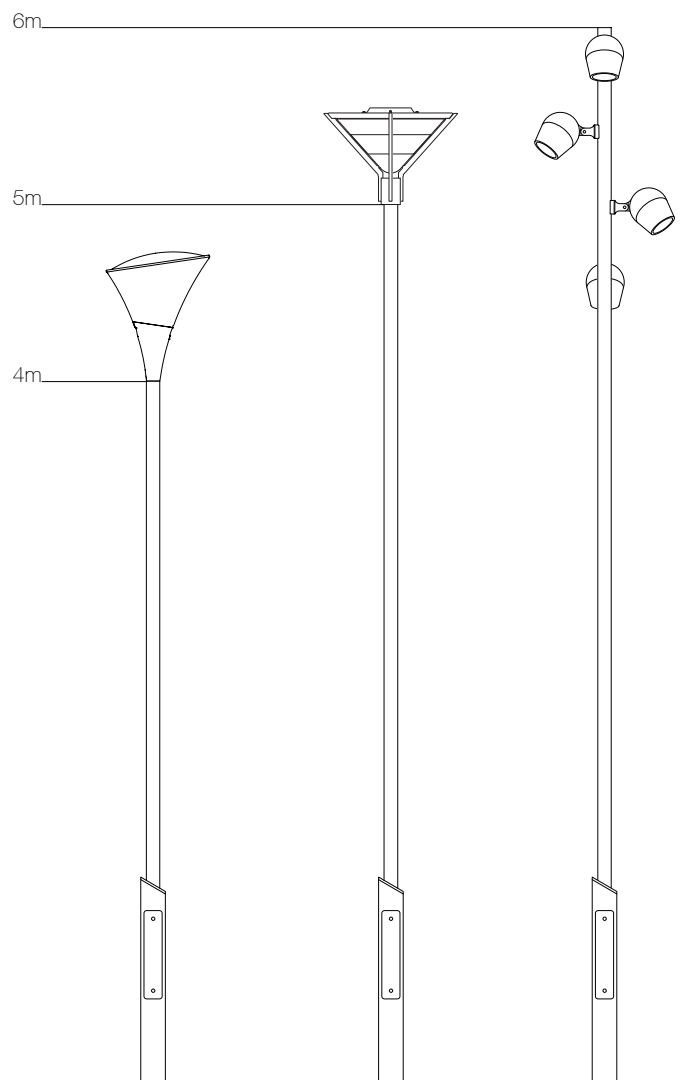



Dimensional Information

Planted Root Option

| Height (m) | BD (mm) | SD (mm) | BH (mm) | SH (mm) | PD (mm) | DH x DW (mm) | Mass (kg) | OTM (kNm) | Shear (kN) | Min. Concrete Dia. (mm) |
|------------|---------|---------|---------|---------|---------|--------------|-----------|-----------|------------|-------------------------|
| 4 | 139,7 | 76,1 | 1175 | 2825 | 800 | 500 x 100 | 34,8 | 4,42 | 1,34 | 540 |
| 5 | 139,7 | 76,1 | 1175 | 3825 | 800 | 500 x 100 | 39,7 | 4,23 | 1,18 | 500 |
| 6 | 139,7 | 76,1 | 1175 | 4825 | 1000 | 500 x 100 | 46,7 | 4,17 | 1,14 | 260 |

Flange Plated Option

| Height (m) | BD (mm) | SD (mm) | BH (mm) | SH (mm) | DH x DW (mm) | SL x T x BC (mm) | Anchor Bolts | Mass (kg) | OTM (kNm) | Shear (kN) | Concrete Foundation Size (mm) |
|------------|---------|---------|---------|---------|--------------|------------------|--------------|-----------|-----------|------------|-------------------------------|
| 4 | 139,7 | 76,1 | 1175 | 2825 | 500 x 100 | 260 x 15 x 200 | M18 x 400 | 34,8 | 4,42 | 1,34 | 400 sq x 600 h |
| 5 | 139,7 | 76,1 | 1175 | 3825 | 500 x 100 | 260 x 15 x 200 | M18 x 400 | 39,7 | 4,23 | 1,18 | 400 sq x 600 h |
| 6 | 139,7 | 76,1 | 1175 | 4825 | 500 x 100 | 260 x 15 x 200 | M18 x 400 | 46,7 | 4,17 | 1,14 | 400 sq x 600 h |

Headload Capacity Information

| Height (m) | Mounting Arrangement | Projection (m) | Weight (kg) | Extra Light | Light | Medium | Heavy | Extra Heavy |
|------------|----------------------|----------------|-------------|-------------|-------|--------|-------|-------------|
| 4 | Post Top | N/A | 50 | 1,00 | 0,87 | 0,79 | 0,72 | 0,56 |
| | Single Arm | 0,5 | 15 | 0,69 | 0,59 | 0,54 | 0,49 | 0,38 |
| | Double Arm | 0,5 | 15 | 0,46 | 0,39 | 0,35 | 0,32 | 0,24 |
| 5 | Post Top | N/A | 50 | 0,59 | 0,50 | 0,45 | 0,40 | 0,29 |
| | Single Arm | 0,5 | 15 | 0,48 | 0,41 | 0,36 | 0,32 | 0,22 |
| | Double Arm | 0,5 | 15 | 0,26 | 0,22 | 0,19 | 0,17 | 0,11 |
| 6 | Post Top | N/A | 30 | 0,38 | 0,31 | 0,27 | 0,23 | 0,15 |
| | Single Arm | 0,5 | 15 | 0,29 | 0,23 | 0,20 | 0,16 | 0,09 |
| | Double Arm | 0,5 | 15 | 0,14 | 0,11 | 0,09 | 0,07 | 0,03 |

Dimensions and technical information given as an indication.

See diagrams beginning on page 308 for info regarding the moments and abbreviations used in above tables.

Valmont reserves the right to make, without delay and without prior notice, the technical or aesthetic modifications that it deems necessary to improve the products of the Standard Collection.

Tree Column 2



Description

An organically designed lighting column offering a range of light point heights and mounting configurations.

This columns can be used to create an eye catching installation in many public spaces.

Specifications

Tree Column 2 structures are available in heights ranging between 4 and 6 metres and are best suited for post top or side mount applications.

Multiple mounting height arrangements are available.

Valmont Stainton operates a Quality Assurance system which complies with requirements of BS EN ISO 9001.

Our welders and welding procedures are independently certified in accordance with EN ISO 9606 and EN ISO 15607.

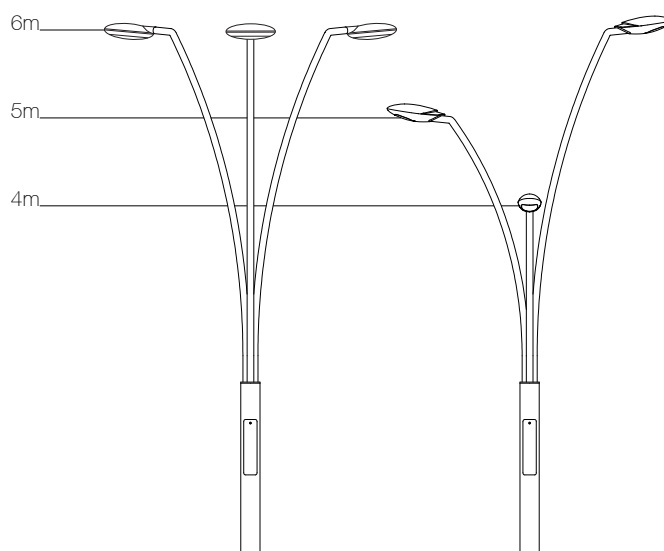
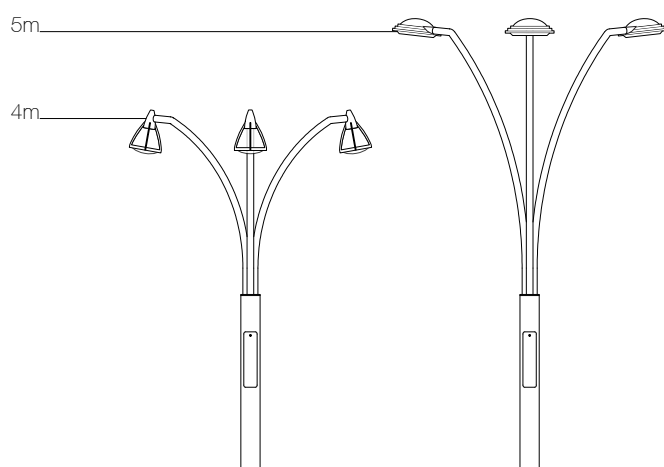



Dimensional Information

Planted Root Option

| Height (m) | BD (mm) | SD (mm) | PD (mm) | BH (m) | SH (m) | DH x DW (mm) | Mass (kg) | OTM (kNm) | Shear (kN) | Min. Concrete Dia. (mm) |
|------------|---------|---------|---------|--------|---------|--------------|-----------|-----------|------------|-------------------------|
| 4 | 219,1 | 76,1 | 800 | 2 | 2 | 600 x 115 | 115 | 15,29 | 4,35 | 815 |
| 5 | 219,1 | 76,1 | 800 | 2 | 3 | 600 x 115 | 133 | 15,53 | 3,77 | 803 |
| 6 | 219,1 | 76,1 | 1000 | 2 | 4 | 600 x 115 | 146 | 15,89 | 3,49 | 804 |
| 4, 5, 6 | 219,1 | 76,1 | 1000 | 2 | 2, 3, 4 | 600 x 115 | 127 | 12,43 | 3,13 | 629 |

Flange Plated Option

| Height (m) | BD (mm) | SD (mm) | BH (m) | SH (m) | DH x DW (mm) | SL x T x BC (mm) | Anchor Bolts | Mass (kg) | OTM (kNm) | Shear (kN) | Concrete Foundation Size (mm) |
|------------|---------|---------|--------|---------|--------------|------------------|--------------|-----------|-----------|------------|-------------------------------|
| 4 | 219,1 | 76,1 | 2 | 2 | 600 x 115 | 420 x 20 x 300 | M24 x 820 | 116 | 15,29 | 4,35 | 600 sq x 1000 h |
| 5 | 219,1 | 76,1 | 2 | 3 | 600 x 115 | 420 x 20 x 300 | M24 x 820 | 134 | 15,53 | 3,77 | 600 sq x 1000 h |
| 6 | 219,1 | 76,1 | 2 | 4 | 600 x 115 | 420 x 20 x 300 | M24 x 820 | 142 | 15,89 | 3,49 | 600 sq x 1000 h |
| 4, 5, 6 | 219,1 | 76,1 | 2 | 2, 3, 4 | 600 x 115 | 420 x 20 x 300 | M24 x 820 | 123 | 12,43 | 3,13 | 500 sq x 1000 h |

Headload Capacity Information

| Height (m) | Mounting Arrangement | Projection (m) | Weight (kg) | Extra Light | Light | Medium | Heavy | Extra Heavy |
|------------|----------------------|----------------|-------------|-------------|-------|--------|-------|-------------|
| 4 | Triple Arm | 1 | 15 | 1,41 | 1,24 | 1,13 | 1,04 | 0,83 |
| 5 | Triple Arm | 1 | 15 | 0,99 | 0,85 | 0,78 | 0,71 | 0,55 |
| 6 | Triple Arm | 1 | 15 | 0,69 | 0,58 | 0,52 | 0,48 | 0,35 |
| 4, 5, 6 | Triple Arm | 1 | 15 | 0,70 | 0,59 | 0,53 | 0,48 | 0,36 |

Dimensions and technical information given as an indication.

See diagrams beginning on page 308 for info regarding the moments and abbreviations used in above tables.

Valmont reserves the right to make, without delay and without prior notice, the technical or aesthetic modifications that it deems necessary to improve the products of the Standard Collection.

Diamond Column



Description

The Diamond column puts a modern twist on a common profile. Typically, a column with a square profile would see the lanterns mounted on the flat sides of the mast. The Diamond Column rotates the mounting positions of the lanterns by 45° to the corners. This design change creates a contemporary silhouette that plays with light and shadow.

Specifications

The Diamond columns is available in heights ranging between 4 and 6 metres.

Valmont Stainton operates a Quality Assurance system which complies with requirements of BS EN ISO 9001.

Our welders and welding procedures are independently certified in accordance with EN ISO 9606 and EN ISO 15607.

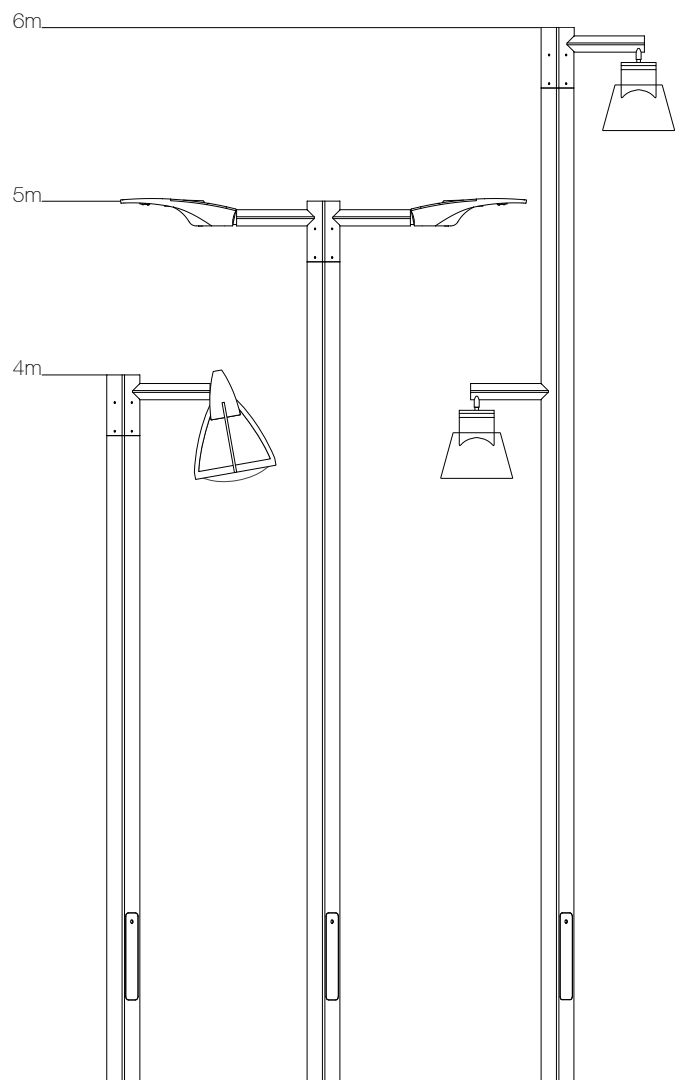



Dimensional Information

Planted Root Option

| Height (m) | BD (mm) | TD (mm) | PD (mm) | DH x DW (mm) | Mass (kg) | OTM (kNm) | Shear (kN) | Min. Concrete Dia. (mm) |
|------------|---------|---------|---------|--------------|-----------|-----------|------------|-------------------------|
| 4 | 140 | 140 | 1000 | 500 x 100 | 108 | 19,43 | 6,17 | 1036 |
| 5 | 140 | 140 | 1000 | 500 x 100 | 124 | 19,81 | 5,23 | 1024 |
| 6 | 140 | 140 | 1000 | 500 x 100 | 150 | 20,57 | 4,79 | 1041 |

Flange Plated Option

| Height (m) | BD (mm) | TD (mm) | DH x DW (mm) | SL x T x BC (mm) | Anchor Bolts | Mass (kg) | OTM (kNm) | Shear (kN) | Concrete Foundation Size (mm) |
|------------|---------|---------|--------------|------------------|--------------|-----------|-----------|------------|-------------------------------|
| 4 | 140 | 140 | 500 x 100 | 420 x 20 x 300 | M24 X 820 | 115 | 19,43 | 6,17 | 600 sq x 1200 h |
| 5 | 140 | 140 | 500 x 100 | 420 x 20 x 300 | M24 X 820 | 137 | 19,81 | 5,23 | 600 sq x 1200 h |
| 6 | 140 | 140 | 500 x 100 | 420 x 20 x 300 | M24 X 820 | 159 | 20,57 | 4,79 | 600 sq x 1200 h |

Headload Capacity Information

| Height (m) | Mounting Arrangement | Projection (m) | Weight (kg) | Extra Light | Light | Medium | Heavy | Extra Heavy |
|------------|----------------------|----------------|-------------|-------------|-------|--------|-------|-------------|
| 4 | Single Arm | 0,5 | 15 | 2,89 | 2,51 | 2,30 | 2,09 | 1,65 |
| | Double Arm | 0,5 | 15 | 2,62 | 2,28 | 2,08 | 1,89 | 1,47 |
| | Quadruple Arm | 0,5 | 15 | 1,53 | 1,33 | 1,21 | 1,11 | 0,86 |
| | Single Arm | 1,0 | 15 | 1,93 | 1,67 | 1,52 | 1,38 | 1,07 |
| | Double Arm | 1,0 | 15 | 1,72 | 1,48 | 1,34 | 1,20 | 0,91 |
| | Quadruple Arm | 1,0 | 15 | 1,13 | 0,97 | 0,87 | 0,79 | 0,59 |
| 5 | Single Arm | 0,5 | 15 | 2,36 | 2,05 | 1,86 | 1,68 | 1,28 |
| | Double Arm | 0,5 | 15 | 1,95 | 1,67 | 1,52 | 1,37 | 1,04 |
| | Quadruple Arm | 0,5 | 15 | 1,08 | 0,93 | 0,85 | 0,76 | 0,57 |
| | Single Arm | 1,0 | 15 | 1,62 | 1,39 | 1,26 | 1,13 | 0,85 |
| | Double Arm | 1,0 | 15 | 1,32 | 1,12 | 1,00 | 0,90 | 0,64 |
| | Quadruple Arm | 1,0 | 15 | 0,82 | 0,69 | 0,62 | 0,55 | 0,39 |
| 6 | Single Arm | 0,5 | 15 | 1,92 | 1,64 | 1,47 | 1,31 | 0,97 |
| | Double Arm | 0,5 | 15 | 1,46 | 1,24 | 1,11 | 0,98 | 0,71 |
| | Quadruple Arm | 0,5 | 15 | 0,78 | 0,66 | 0,59 | 0,52 | 0,38 |
| | Single Arm | 1,0 | 15 | 1,33 | 1,12 | 1,00 | 0,89 | 0,64 |
| | Double Arm | 1,0 | 15 | 1,00 | 0,83 | 0,73 | 0,64 | 0,43 |
| | Quadruple Arm | 1,0 | 15 | 0,59 | 0,49 | 0,43 | 0,37 | 0,24 |

Dimensions and technical information given as an indication.

See diagrams beginning on page 308 for info regarding the moments and abbreviations used in above tables.

Valmont reserves the right to make, without delay and without prior notice, the technical or aesthetic modifications that it deems necessary to improve the products of the Standard Collection.

Raked Column

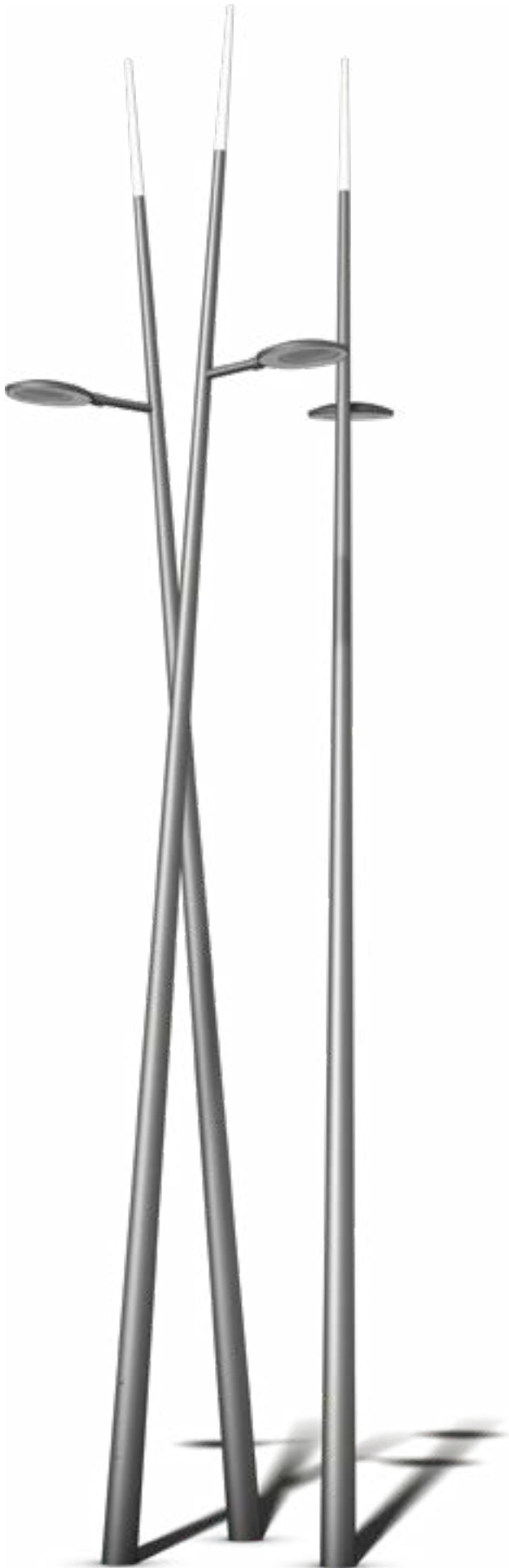

Description

Valmont Stainton Raked Columns are a range of conical steel lighting columns that have been tilted 5 degrees from vertical. This subtle modification transforms standard into bespoke and creates a powerful visual impact.

Seamless weld technology is used to produce a column with a nearly invisible weld. The absence of a vertical seam elevates the aesthetic of the column giving it a more modern and contemporary feel.

Specifications

Light Duty SWT columns (12mm taper) are available in mounting heights from 4 to 12 metres.

Raked Columns be used for post top and side mount applications and can support multiple projectors.

Valmont Stainton operates a Quality Assurance system which complies with requirements of BS EN ISO 9001.

Our welders and welding procedures are independently certified in accordance with EN ISO 9606 and EN ISO 15607.

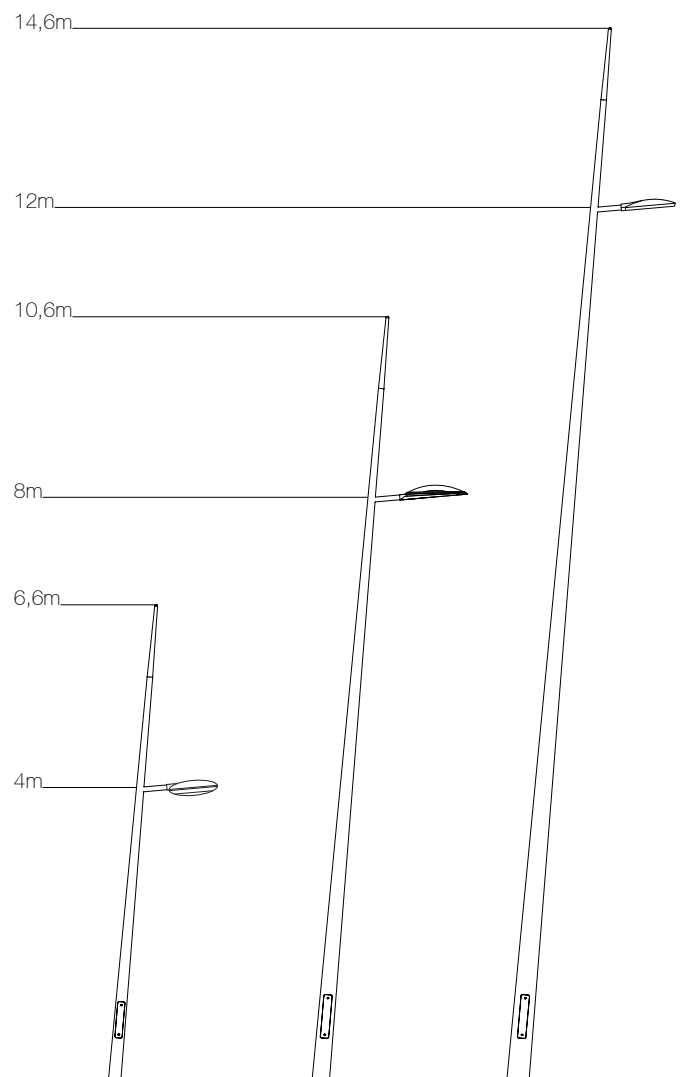



Dimensional Information

Flange Plated Option

| Height (m) | BD (mm) | TD (mm) | FL (mm) | DH x DW (mm) | SL x T x BC (mm) | Anchor Bolts | Mass (kg) | OTM (kNm) | Shear (kN) | Concrete Foundation Size (mm) |
|------------|---------|---------|---------|--------------|------------------|--------------|-----------|-----------|------------|-------------------------------|
| 4 | 173 | 76 | 1000 | 500 x 100 | 260 x 20 x 200 | M18/20 x 400 | 88 | 5,41 | 1,41 | 400 sq x 700 h |
| 5 | 190 | 76 | 1000 | 500 x 100 | 260 x 20 x 200 | M18/20 x 400 | 100 | 7,65 | 1,69 | 400 sq x 800 h |
| 6 | 207 | 76 | 1000 | 500 x 100 | 400 x 20 x 300 | M24 x 820 | 130 | 10,13 | 1,94 | 500 sq x 900 h |
| 8 | 241 | 76 | 1000 | 600 x 115 | 400 x 20 x 300 | M24 x 820 | 200 | 20,04 | 3,00 | 600 sq x 1200 h |
| 10 | 275 | 76 | 1000 | 600 x 115 | 400 x 20 x 300 | M24 x 820 | 250 | 29,16 | 3,72 | 700 sq x 1300 h |
| 12 | 309 | 76 | 1000 | 600 x 115 | 400 x 20 x 300 | M24 x 820 | 307 | 37,86 | 4,29 | 800 sq x 1500 h |

* FL indicates finial length.

Headload Capacity Information

| Height (m) | Mounting Arrangement | Projection (m) | Weight (kg) | Extra Light | Light | Medium | Heavy | Extra Heavy |
|------------|----------------------|----------------|-------------|-------------|-------|--------|-------|-------------|
| 4 | Single Arm | 0,50 | 15 | 0,77 | 0,65 | 0,59 | 0,52 | 0,39 |
| | Single Arm | 1,00 | 15 | 0,55 | 0,46 | 0,42 | 0,36 | 0,26 |
| 5 | Single Arm | 0,50 | 15 | 0,96 | 0,80 | 0,73 | 0,65 | 0,49 |
| | Single Arm | 1,00 | 15 | 0,72 | 0,60 | 0,55 | 0,48 | 0,35 |
| 6 | Single Arm | 0,50 | 15 | 1,08 | 0,92 | 0,83 | 0,75 | 0,56 |
| | Single Arm | 1,00 | 15 | 0,86 | 0,72 | 0,65 | 0,58 | 0,42 |
| 8 | Single Arm | 0,50 | 15 | 1,28 | 1,11 | 1,00 | 0,90 | 0,67 |
| | Single Arm | 1,00 | 15 | 1,06 | 0,91 | 0,82 | 0,73 | 0,53 |
| 10 | Single Arm | 0,50 | 15 | 1,42 | 1,21 | 1,10 | 0,98 | 0,72 |
| | Single Arm | 1,00 | 15 | 1,23 | 1,04 | 0,93 | 0,83 | 0,60 |
| 12 | Single Arm | 0,50 | 15 | 1,50 | 1,26 | 1,11 | 0,98 | 0,66 |
| | Single Arm | 1,00 | 15 | 1,25 | 1,10 | 0,99 | 0,87 | 0,62 |

Dimensions and technical information given as an indication.

See diagrams beginning on page 308 for info regarding the moments and abbreviations used in above tables.

Valmont reserves the right to make, without delay and without prior notice, the technical or aesthetic modifications that it deems necessary to improve the products of the Standard Collection.

XHD Column



Description

Based on the conical SWT, the Extra Heavy Duty (XHD) range from Valmont brings added flexibility to your project.

XHD columns are designed for use as a multi-pole. Specialist equipment can be housed within and also on the exterior of the structure to enable value added benefits to be realised. The installation of festive decorations, banners, CCTV, sound and vision products and user power supply are now easily within reach.

Specifications

XHD columns are available in mounting heights from 6 to 12 metres.

They can be used for post top applications or supplied with demountable or integral bracket arm arrangements.

Valmont Stanton operates a Quality Assurance system which complies with requirements of BS EN ISO 9001.

Our welders and welding procedures are independently certified in accordance with EN ISO 9606 and EN ISO 15607.

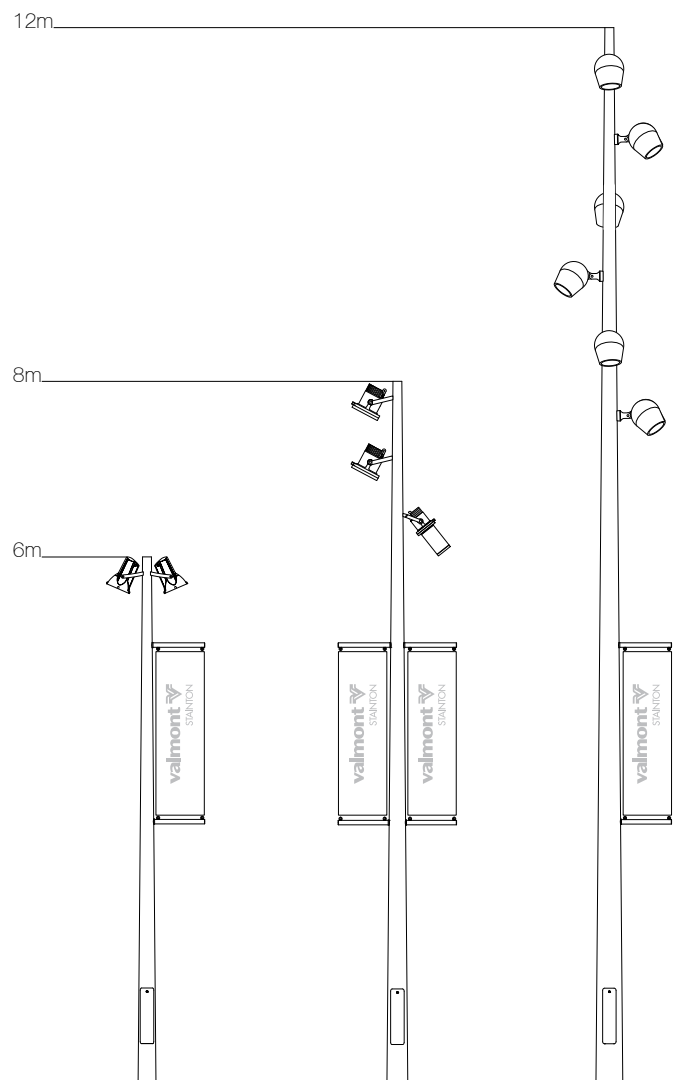



Dimensional Information

Planted Root Option

| Height (m) | BD (mm) | TD (mm) | PD (mm) | DH x DW (mm) | Mass (kg) | OTM (kNm) | Shear (kN) | Min. Concrete Dia. (mm) |
|------------|---------|---------|---------|--------------|-----------|-----------|------------|-------------------------|
| 6 | 220 | 101 | 1000 | 600 x 115 | 121 | 23,45 | 4,58 | 1187 |
| 8 | 257,4 | 101 | 1200 | 600 x 115 | 173 | 36,90 | 5,94 | 1070 |
| 10 | 296,5 | 101 | 1500 | 600 x 115 | 237 | 51,15 | 7,16 | 759 |

Flange Plated Option

| Height (m) | BD (mm) | TD (mm) | DH x DW (mm) | SL x T x BC (mm) | Anchor Bolts | Mass (kg) | OTM (kNm) | Shear (kN) | Concrete Foundation Size (mm) |
|------------|---------|---------|--------------|------------------|--------------|-----------|-----------|------------|-------------------------------|
| 6 | 203 | 101 | 600 x 115 | 420 x 25 x 300 | M24 x 820 | 128 | 23,45 | 4,58 | 700 sq x 1200 h |
| 8 | 237 | 101 | 600 x 115 | 420 x 25 x 300 | M24 x 820 | 172 | 36,90 | 5,94 | 800 sq x 1500 h |
| 10 | 271 | 101 | 600 x 115 | 420 x 25 x 300 | M24 x 820 | 220 | 51,15 | 7,16 | 900 sq x 1700 h |
| 12 | 305 | 101 | 600 x 115 | 420 x 25 x 300 | M24 x 820 | 277 | 66,41 | 7,81 | 1000 sq x 1900 h |

Headload Capacity Information

| Height (m) | Mounting Arrangement | Projection (m) | Weight (kg) | Extra Light | Light | Medium | Heavy | Extra Heavy |
|------------|----------------------|----------------|-------------|-------------|-------|--------|-------|-------------|
| 6 | Post Top | N/A | 50 | 3,00 | 2,46 | 2,14 | 1,85 | 1,19 |
| | Single Arm | 0.5m | 15 | 2,07 | 1,69 | 1,48 | 1,26 | 0,82 |
| 8 | Post Top | N/A | 50 | 2,79 | 2,36 | 2,08 | 1,85 | 1,30 |
| | Single Arm | 1.0m | 15 | 1,87 | 1,56 | 1,38 | 1,23 | 0,83 |
| 10 | Post Top | N/A | 50 | 3,04 | 2,59 | 2,34 | 2,08 | 1,50 |
| | Single Arm | 1.0m | 15 | 2,12 | 1,87 | 1,73 | 1,56 | 1,13 |
| 12 | Post Top | N/A | 50 | 3,18 | 2,71 | 2,46 | 2,18 | 1,60 |
| | Single Arm | 1.0m | 15 | 2,01 | 1,77 | 1,64 | 1,50 | 1,21 |

Note: A banner with dimensions of 2m high x 0.5m has been allowed for within the pole calculation in addition to the figures quoted above.

Dimensions and technical information given as an indication.

See diagrams beginning on page 308 for info regarding the moments and abbreviations used in above tables.

Valmont reserves the right to make, without delay and without prior notice, the technical or aesthetic modifications that it deems necessary to improve the products of the Standard Collection.

Passive Safety Columns



Description

Passively Safe lighting columns, designed, manufactured and tested in the U.K., are the latest product innovations and our 10m and 12m columns are approved to 100HE:2 standard, the highest energy absorption class.

Our conical galvanised structures are planted root as standard, our 100HE:2 energy absorbing passive range is fully compliant to all relative EN specifications (EN40 and EN12767). This family of products are tested at both 100Km/h & 70Km/h resulting in the 100:HE:2 performance class.

Specifications

Available in 10m and 12m mounting heights with single bracket projections of up to 1.5m.

These roadway safety columns can be used for post top applications or supplied with a variety of bracket arm options.

Valmont Stainton operates a Quality Assurance system which complies with requirements of BS EN ISO 9001.

Our welders and welding procedures are independently certified in accordance with EN ISO 9606 and EN ISO 15607.

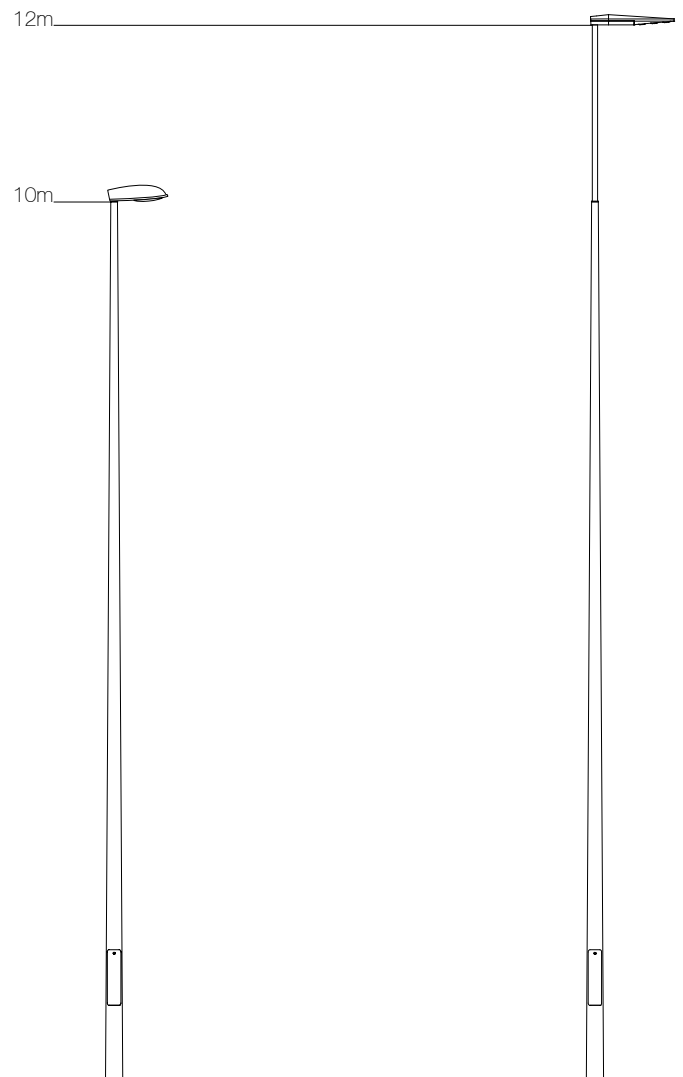



Headload Capacity Information

| Mast (m) | Mounting Arrang. | Weight (kg) | E. Light (24.92m/s) TCAT II | Light (26.5m/s) TCAT II | Medium (27.58m/s) TCAT II | Heavy (28.75m/s) TCAT II | E.Heavy (31.95m/s) TCAT II | E.Light (24.92m/s) TCAT III | Light (26.5m/s) TCAT III | Medium (27.58m/s) TCAT III | Heavy (28.75m/s) TCAT III | E.Heavy (31.95m/s) TCAT III | Design Moment (m.daN) | Shear Load (daN) |
|----------|------------------|-------------|-----------------------------|-------------------------|---------------------------|--------------------------|----------------------------|-----------------------------|--------------------------|----------------------------|---------------------------|-----------------------------|-----------------------|------------------|
| 10 | Post Top | 32 | 0,686 | 0,583 | 0,525 | 0,470 | 0,352 | 0,984 | 0,836 | 0,752 | 0,673 | 0,506 | 1583 | 228 |
| 10 | 0.5m S-Arm | 18 | 0,531 | 0,444 | 0,394 | 0,348 | 0,245 | 0,781 | 0,657 | 0,586 | 0,520 | 0,380 | 1563 | 223 |
| 10 | 1m S-Arm | 18 | 0,424 | 0,348 | 0,305 | 0,264 | 0,179 | 0,642 | 0,534 | 0,472 | 0,415 | 0,292 | 1519 | 219 |
| 10 | 1.5m S-Arm | 16,5 | 0,336 | 0,269 | 0,231 | 0,195 | 0,120 | 0,530 | 0,433 | 0,378 | 0,328 | 0,220 | 1485 | 216 |
| 12 | Post Top | 20 | 0,354 | 0,277 | 0,233 | 0,192 | 0,104 | 0,567 | 0,458 | 0,395 | 0,336 | 0,213 | 1600 | 223 |
| 12 | 0.5m S-Arm | 18 | 0,312 | 0,245 | 0,204 | 0,164 | 0,079 | 0,500 | 0,405 | 0,350 | 0,298 | 0,184 | 1588 | 222 |
| 12 | 0.5m S-Arm | 12 | 0,342 | 0,270 | 0,227 | 0,185 | 0,096 | 0,540 | 0,439 | 0,381 | 0,328 | 0,208 | 1587 | 220 |
| 12 | 1m S-Arm | 14 | 0,256 | 0,194 | 0,158 | 0,125 | 0,047 | 0,429 | 0,340 | 0,291 | 0,244 | 0,145 | 1582 | 222 |
| 12 | 1m S-Arm | 10 | 0,277 | 0,211 | 0,175 | 0,140 | 0,059 | 0,456 | 0,365 | 0,312 | 0,263 | 0,162 | 1579 | 220 |
| 12 | 1.5m S-Arm | 12 | 0,199 | 0,141 | 0,109 | 0,080 | -- | 0,356 | 0,276 | 0,230 | 0,187 | 0,097 | 1579 | 222 |
| 12 | 1.5m S-Arm | 10 | 0,208 | 0,151 | 0,118 | 0,086 | -- | 0,370 | 0,287 | 0,241 | 0,197 | 0,105 | 1577 | 221 |

Foundation Information

Concrete Foundation In Accordance with BS EN 12767:2007. N.A. 7, In Good, Medium & Poor Ground. See Note Below.

| Mast (m) | Weight (kg) | Mounting Arrangement | Good G=630 kN/m ² per m. | Medium G=390 kN/m ² per m. | Poor G=230 kN/m ² per m. |
|----------|-------------|----------------------|--|--|--|
| 10 | 32 | Post Top | Ø0.5m x 1.5m P/Depth | Ø0.75m x 1.5m P/Depth | Ø1.25m x 1.5m P/Depth |
| 10 | 18 | 0.5m Single Arm | Ø0.5m x 1.5m P/Depth | Ø0.75m x 1.5m P/Depth | Ø1.25m x 1.5m P/Depth |
| 10 | 18 | 1m Single Arm | Ø0.5m x 1.5m P/Depth | Ø0.75m x 1.5m P/Depth | Ø1.25m x 1.5m P/Depth |
| 10 | 16,5 | 1.5m S-Arm | Ø0.5m x 1.5m P/Depth | Ø0.75m x 1.5m P/Depth | Ø1.25m x 1.5m P/Depth |
| 12 | 20 | Post Top | Ø0.5m x 1.5m P/Depth | Ø0.75m x 1.5m P/Depth | Ø1.25m x 1.5m P/Depth |
| 12 | 18 | 0.5m S-Arm | Ø0.5m x 1.5m P/Depth | Ø0.75m x 1.5m P/Depth | Ø1.25m x 1.5m P/Depth |
| 12 | 12 | 0.5m S-Arm | Ø0.5m x 1.5m P/Depth | Ø0.75m x 1.5m P/Depth | Ø1.25m x 1.5m P/Depth |
| 12 | 14 | 1m S-Arm | Ø0.5m x 1.5m P/Depth | Ø0.75m x 1.5m P/Depth | Ø1.25m x 1.5m P/Depth |
| 12 | 10 | 1m S-Arm | Ø0.5m x 1.5m P/Depth | Ø0.75m x 1.5m P/Depth | Ø1.25m x 1.5m P/Depth |
| 12 | 12 | 1.5m S-Arm | Ø0.5m x 1.5m P/Depth | Ø0.75m x 1.5m P/Depth | Ø1.25m x 1.5m P/Depth |
| 12 | 10 | 1.5m S-Arm | Ø0.5m x 1.5m P/Depth | Ø0.75m x 1.5m P/Depth | Ø1.25m x 1.5m P/Depth |

Note: Good, Medium & Poor ground descriptions can be found in BD94/07 & PD6547:2004+A1:2009. Foundation size is designed in accordance with BS EN 12767:2007. N.A. 7. Concrete to be plain C25/30 air entrained concrete for frost resistance. Any water present in holes to be removed prior to placing concrete. Column to be located centrally within the foundation.

Dimensions and technical information given as an indication.

See diagrams beginning on page 308 for info regarding the moments and abbreviations used in above tables.

Valmont reserves the right to make, without delay and without prior notice, the technical or aesthetic modifications that it deems necessary to improve the products of the Standard Collection.

CCTV Columns_{Static}



Description

Protecting people and property is an increasingly high priority in the public and private sectors. Transportation Managers are increasingly adding security cameras along roadways and at busy intersections to promote public safety and monitor traffic flow.

Building on a strong heritage with proven results, Valmont offers robust columns for mounting security and traffic cameras. The Valmont team can collaborate with camera suppliers and security system integrators to ensure timely delivery and installation of products.

Specifications

Available in mounting heights from 4 to 10 metres.

Suitable for post top application.

Valmont Stainton operates a Quality Assurance system which complies with requirements of BS EN ISO 9001.

Our welders and welding procedures are independently certified in accordance with EN ISO 9606 and EN ISO 15607.

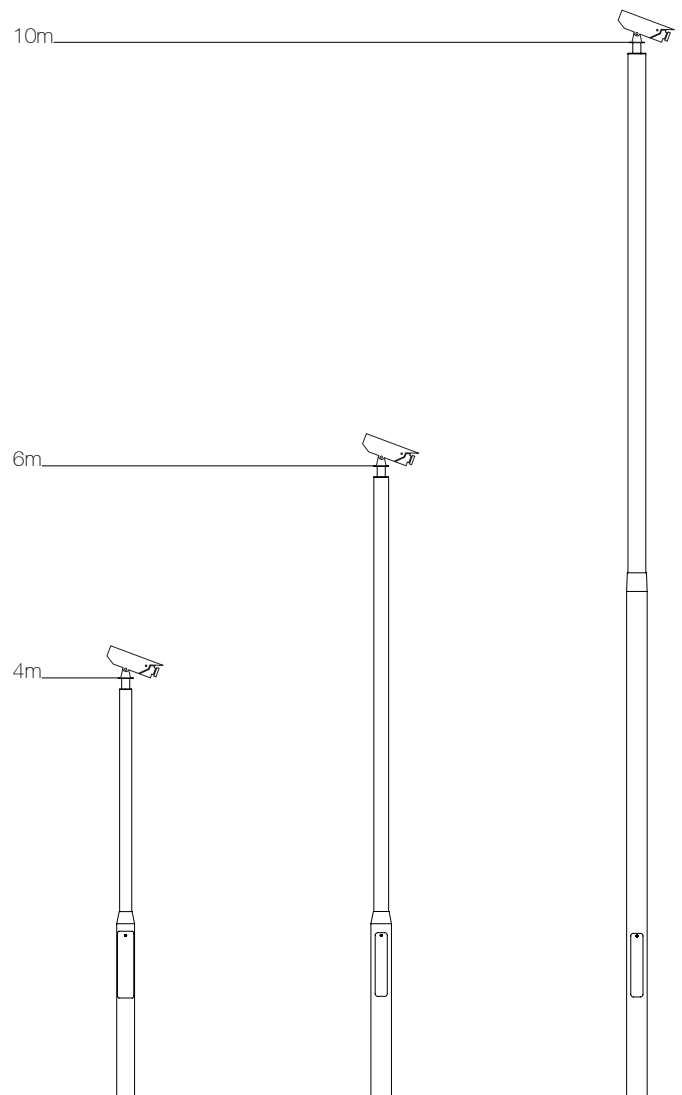



Dimensional Information

Planted Root Option

| Height (m) | BD (mm) | SD (mm) | BH (mm) | SH (mm) | PD (mm) | DH x DW (mm) | Mass (kg) | OTM (kNm) | Shear (kN) | Min. Concrete Dia. (mm) |
|------------|---------|---------|---------|---------|---------|--------------|-----------|-----------|------------|-------------------------|
| 4 | 168,3 | 114,3 | 1800 | 2200 | 800 | 600 x 115 | 65,5 | 4,16 | 1,30 | 504 |
| 5 | 168,3 | 114,3 | 1800 | 3200 | 800 | 600 x 115 | 79,5 | 4,20 | 1,20 | 496 |
| 6 | 193,7 | 139,7 | 1800 | 4200 | 1000 | 600 x 115 | 104,0 | 6,77 | 1,59 | 411 |
| 8 | 193,7 | 139,7 | 4000 | 4000 | 1200 | 600 x 115 | 149,0 | 9,93 | 1,91 | 345 |
| 10 | 193,7 | 168,3 | 5000 | 5000 | 1500 | 600 x 115 | 295,0 | 18,13 | 2,74 | 323 |

Flange Plated Option

| Height (m) | BD (mm) | SD (mm) | BH (mm) | SH (mm) | DH x DW (mm) | SL x T x BC (mm) | Anchor Bolts | Mass (kg) | OTM (kNm) | Shear (kN) | Concrete Foundation Sizes (mm) |
|------------|---------|---------|---------|---------|--------------|------------------|--------------|-----------|-----------|------------|--------------------------------|
| 4 | 168,3 | 114,3 | 1800 | 2200 | 600 x 115 | 300 x 15 x 200 | M18/20 x 400 | 60,0 | 4,16 | 1,30 | 400 sq x 600 h |
| 5 | 168,3 | 114,3 | 1800 | 3200 | 600 x 115 | 300 x 15 x 200 | M18/20 x 400 | 72,5 | 4,20 | 1,20 | 400 sq x 600 h |
| 6 | 193,7 | 139,7 | 1800 | 4200 | 600 x 115 | 420 x 20 x 300 | M24 x 820 | 108,5 | 6,77 | 1,59 | 400 sq x 800 h |
| 8 | 193,7 | 139,7 | 4000 | 4000 | 600 x 115 | 420 x 20 x 300 | M24 x 820 | 149,5 | 9,93 | 1,91 | 500 sq x 900 h |
| 10 | 193,7 | 168,3 | 5000 | 5000 | 600 x 115 | 420 x 20 x 300 | M24 x 820 | 273,0 | 18,13 | 2,74 | 600 sq x 1100 h |

Headload Capacity Information

| Height (m) | Mounting Config. | Weight (kg) | Coastal Location | | | | | | Inland Location | | | | | |
|------------|------------------|-------------|--------------------------|--------------------------|--------------------------|--------------------------|--------------------------|--------------------------|--------------------------|--------------------------|--------------------------|--------------------------|--------------------------|--------------------------|
| | | | 22 mps (m ²) | 23 mps (m ²) | 24 mps (m ²) | 25 mps (m ²) | 26 mps (m ²) | 27 mps (m ²) | 22 mps (m ²) | 23 mps (m ²) | 24 mps (m ²) | 25 mps (m ²) | 26 mps (m ²) | 27 mps (m ²) |
| 4 | Post Top | 40 | 0,74 | 0,66 | 0,60 | 0,54 | 0,50 | 0,45 | 0,71 | 0,64 | 0,58 | 0,53 | 0,48 | 0,44 |
| 5 | Post Top | 40 | 0,43 | 0,38 | 0,34 | 0,30 | 0,27 | 0,24 | 0,40 | 0,36 | 0,32 | 0,28 | 0,25 | 0,23 |
| 6 | Post Top | 40 | 0,58 | 0,52 | 0,47 | 0,42 | 0,38 | 0,35 | 0,54 | 0,48 | 0,44 | 0,39 | 0,36 | 0,33 |
| 8 | Post Top | 40 | 0,49 | 0,43 | 0,38 | 0,34 | 0,31 | 0,28 | 0,44 | 0,39 | 0,35 | 0,31 | 0,28 | 0,24 |
| 10 | Post Top | 40 | 0,73 | 0,64 | 0,55 | 0,48 | 0,41 | 0,35 | 0,64 | 0,55 | 0,47 | 0,41 | 0,35 | 0,29 |

Dimensions and technical information given as an indication.

See diagrams beginning on page 308 for info regarding the moments and abbreviations used in above tables.

Valmont reserves the right to make, without delay and without prior notice, the technical or aesthetic modifications that it deems necessary to improve the products of the Standard Collection.

CCTV Columns Hinged



Description

Protecting people and property is an increasingly high priority in the public and private sectors. Transportation Managers are increasingly adding security cameras along roadways and at busy intersections to promote public safety and monitor traffic flow.

Building on a strong heritage with proven results, Valmont offers robust columns for mounting security and traffic cameras. The Valmont team can collaborate with camera suppliers and security system integrators to ensure timely delivery and installation of products.

Specifications

Available in mounting heights from 4 to 10 metres.

Suitable for post top application.

Valmont Stainton operates a Quality Assurance system which complies with requirements of BS EN ISO 9001.

Our welders and welding procedures are independently certified in accordance with EN ISO 9606 and EN ISO 15607.

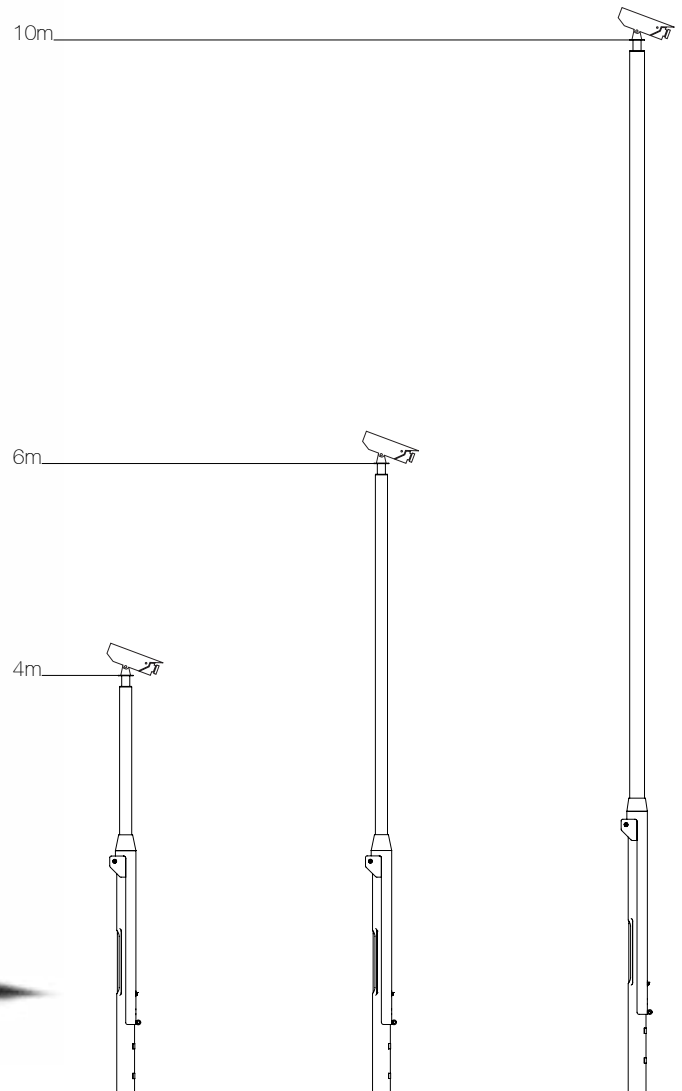



Dimensional Information

Planted Root Option

| Height (m) | BD (mm) | SK D (mm) | SD (mm) | BH (mm) | SH (mm) | PD (mm) | DH x DW (mm) | Mass (kg) | OTM (kNm) | Shear (kN) | Concrete Foundation Sizes (mm) |
|------------|---------|-----------|---------|---------|---------|---------|--------------|-----------|-----------|------------|--------------------------------|
| 4 | 168,3 | 193,7 | 114,3 | 2500 | 1500 | 800 | 600 x 115 | 73,5 | 5,30 | 1,61 | 642 |
| 5 | 168,3 | 193,7 | 114,3 | 2500 | 2500 | 800 | 600 x 115 | 82,0 | 5,02 | 1,40 | 593 |
| 6 | 168,3 | 193,7 | 114,3 | 2500 | 3500 | 1000 | 600 x 115 | 101,0 | 5,24 | 1,37 | 318 |
| 8 | 168,3 | 193,7 | 139,7 | 2500 | 5500 | 1200 | 600 x 115 | 170,0 | 8,48 | 1,73 | 295 |
| 10 | 168,3 | 193,7 | 139,7 | 2850 | 6500 | 1500 | 600 x 115 | 242,5 | 10,65 | 1,93 | 190 |

Flange Plated Option

| Height (m) | BD (mm) | SK D (mm) | SD (mm) | BH (mm) | SH (mm) | DH x DW (mm) | SL x T x BC (mm) | Anchor Bolts | Mass (kg) | OTM (kNm) | Shear (kN) | Concrete Foundation Sizes (mm) |
|------------|---------|-----------|---------|---------|---------|--------------|------------------|--------------|-----------|-----------|------------|--------------------------------|
| 4 | 168,3 | 193,7 | 114,3 | 2500 | 1500 | 600 x 115 | 300 x 15 x 200 | M18/20 x 400 | 68,5 | 5,30 | 1,61 | 400 sq x 700 h |
| 5 | 168,3 | 193,7 | 114,3 | 2500 | 2500 | 600 x 115 | 300 x 15 x 200 | M18/20 x 400 | 77,0 | 5,02 | 1,40 | 400 sq x 700 h |
| 6 | 168,3 | 193,7 | 114,3 | 2500 | 3500 | 600 x 115 | 300 x 15 x 200 | M18/20 x 400 | 90,5 | 5,24 | 1,37 | 400 sq x 700 h |
| 8 | 168,3 | 193,7 | 139,7 | 2500 | 5500 | 600 x 115 | 300 x 15 x 200 | M18/20 x 400 | 155,5 | 8,48 | 1,73 | 500 sq x 800 h |
| 10 | 168,3 | 193,7 | 139,7 | 2850 | 7150 | 600 x 115 | 420 x 20 x 300 | M24 x 820 | 228,0 | 10,65 | 1,93 | 500 sq x 900 h |

Headload Capacity Information

| Height (m) | Mounting Config. | Weight (kg) | Coastal Location | | | | | | Inland Location | | | | | |
|------------|------------------|-------------|--------------------------|--------------------------|--------------------------|--------------------------|--------------------------|--------------------------|--------------------------|--------------------------|--------------------------|--------------------------|--------------------------|--------------------------|
| | | | 22 mps (m ²) | 23 mps (m ²) | 24 mps (m ²) | 25 mps (m ²) | 26 mps (m ²) | 27 mps (m ²) | 22 mps (m ²) | 23 mps (m ²) | 24 mps (m ²) | 25 mps (m ²) | 26 mps (m ²) | 27 mps (m ²) |
| 4 | Post Top | 40 | 0,99 | 0,89 | 0,81 | 0,74 | 0,67 | 0,61 | 0,96 | 0,87 | 0,78 | 0,71 | 0,65 | 0,59 |
| 5 | Post Top | 40 | 0,55 | 0,49 | 0,44 | 0,39 | 0,36 | 0,32 | 0,52 | 0,46 | 0,42 | 0,37 | 0,34 | 0,30 |
| 6 | Post Top | 40 | 0,34 | 0,30 | 0,26 | 0,23 | 0,20 | 0,18 | 0,31 | 0,27 | 0,24 | 0,21 | 0,19 | 0,17 |
| 8 | Post Top | 40 | 0,32 | 0,28 | 0,24 | 0,21 | 0,19 | 0,17 | 0,29 | 0,25 | 0,22 | 0,19 | 0,17 | 0,15 |
| 10 | Post Top | 20 | 0,18 | 0,15 | 0,12 | 0,10 | 0,09 | 0,07 | 0,15 | 0,13 | 0,11 | 0,09 | 0,07 | 0,05 |
| 10 | Post Top | 10 | 0,19 | 0,16 | 0,13 | 0,11 | 0,10 | 0,08 | 0,16 | 0,13 | 0,11 | 0,10 | 0,08 | 0,05 |

Dimensions and technical information given as an indication.

See diagrams beginning on page 308 for info regarding the moments and abbreviations used in above tables.

Valmont reserves the right to make, without delay and without prior notice, the technical or aesthetic modifications that it deems necessary to improve the products of the Standard Collection.

Slipper Columns



Description

The Slipper Column is a tubular steel structure which can be installed without the need for re-cabing. As its name suggests, the Slipper Column is designed to fit over a preexisting concrete column. Simply cut down the old concrete columns and slip over the new steel column.

Specifications

Valmont Stainton manufactures a wide range of tubular steel slipper lighting columns from 5 to 6 metres.

The standard corrosion protection system is hot dip galvanised to BS EN 1461. In addition, a variety of root treatments and full paint specification options are available.

Valmont Stainton operates a Quality Assurance system which complies with requirements of BS EN ISO 9001.

Our welders and welding procedures are independently certified in accordance with EN ISO 9606 and EN ISO 15607.

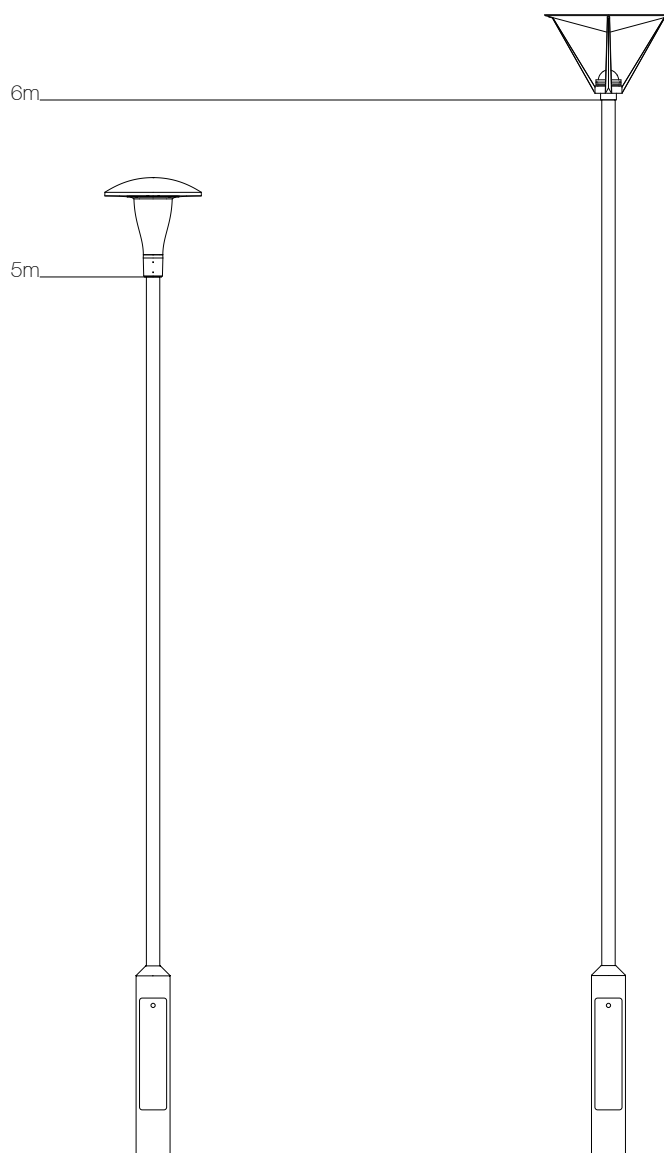



Dimensional Information

Planted Root Option

| Height (m) | BD (mm) | SD (mm) | BH (mm) | SH (mm) | PD (mm) | DH x DW (mm) | Mass (kg) | OTM (kNm) | Shear (kN) | Min. Concrete Dia. (mm) |
|------------|---------|---------|---------|---------|---------|--------------|-----------|-----------|------------|-------------------------|
| 5 | 193,7 | 76,1 | 1100 | 3900 | 600 | 800 x 115 | 57 | 3,80 | 1,08 | 863 |
| 5 | 193,7 | 76,1 | 1100 | 3900 | 600 | 600 x 115 | 57 | 3,79 | 1,08 | 862 |
| 6 | 193,7 | 76,1 | 1100 | 4900 | 600 | 800 x 115 | 62 | 4,14 | 1,10 | 930 |
| 6 | 193,7 | 76,1 | 1100 | 4900 | 600 | 600 x 115 | 62 | 4,15 | 1,10 | 931 |

Headload Capacity Information

| Height (m) | Mounting Arrangement | Projection (m) | Weight (kg) | Extra Light | Light | Medium | Heavy | Extra Heavy |
|------------|----------------------|----------------|-------------|-------------|-------|--------|-------|-------------|
| 5 | Post Top | N/A | 20 | 0,30 | 0,30 | 0,30 | 0,30 | 0,30 |
| 6 | Post Top | N/A | 20 | 0,30 | 0,30 | 0,30 | 0,27 | 0,18 |

Dimensions and technical information given as an indication.

See diagrams beginning on page 308 for info regarding the moments and abbreviations used in above tables.

Valmont reserves the right to make, without delay and without prior notice, the technical or aesthetic modifications that it deems necessary to improve the products of the Standard Collection.

VriPod



Description

The aim of this line of theatrical columns was to focus on transparency, without neglecting the technical aspects of this style of lighting. The structure is designed to accommodate many different types of projectors, at various heights and angles, all the while putting its stamp on the space without cluttering the environment.

Due to the highly customisable nature of the VriPod range, detailed dimensional and capacity information is calculated on a per-project basis. For more information on this exciting range of columns contact your local Valmont representative.

Specifications

100% High-Strength Steel range, incorporating 30% Recycled Steel. S235 Steel.

AlSi7Mg Aluminium alloy half collars.

The range has been conceived and developed in accordance with Eurocode standards, parts 1 & 3

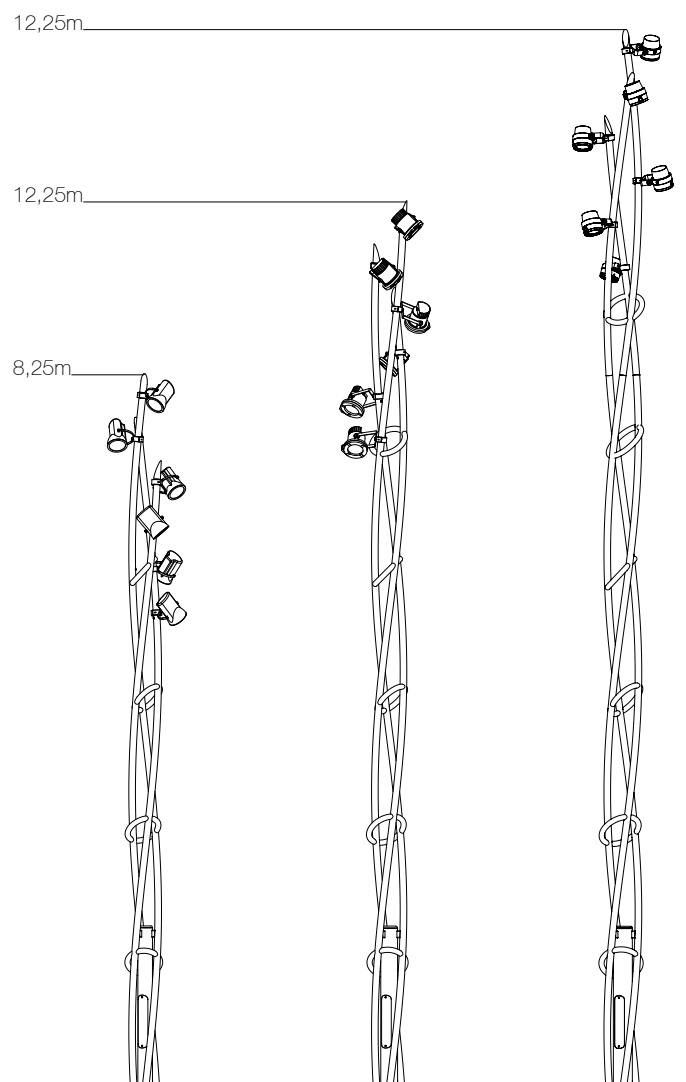

Galvanised Steel



Solar Columns

Harnessing the power of the Sun...

To meet the growing demand for renewable resource solutions in the UK and for export, Valmont Structures offers galvanised steel light poles with mounts for solar panels.

Solar lighting columns are an environmentally friendly option when it comes to public lighting. There are many advantages to solar lighting such as...

*Pollution free energy which causes no greenhouse gas emission after installation.

*Virtually no maintenance as solar panels last up to 30 years.

*Available every day of the year, even cloudy days produce some power.



Functional or decorative...

The aesthetic design of a solar lighting column can vary from project to project. No matter if your application requires a purely functional design or something a bit more decorative, Valmont has a Solar Column to fit your needs.





Designed for durability...

Due to their added surface area, the wind and snow loads observed on Solar columns can be much higher than those seen on standard lighting columns. These added forces are taken into account each time Valmont designs and engineers a solar column. Valmont solar columns ensure functionality, strength, and durability.



Aluminium Columns Functional and Decorative



Project Lead: Thorn UK | Installation: Derby University

Aluminium



Tubular Aluminium
Conical Aluminium
Evolution
Candella
Diva²
Idyline
Sillem
Annapurna
Ceedji



Tubular Aluminium



Description

Aluminium lighting columns are manufactured using an extruding process then spun to form cylindrical sections into which door openings and cable entry slots are cut. The columns are heat-treated by annealing in an oven and an anti-corrosion root treatment is applied resulting in a true seamless lightweight lighting structure. Columns are manufactured from AL6060-T5 with a naturally decorative brushed surface finishing to 120GR.

Specifications

Tubular aluminium lighting columns are available in mounting heights from 3-5 metres. These columns can be used for post top applications or supplied with demountable or integral bracket arm arrangements.

Valmont Stainton operates a Quality Assurance system which complies with requirements of BS EN ISO 9001.

Our welders and welding procedures are independently certified in accordance with EN ISO 9606 and EN ISO 15607.

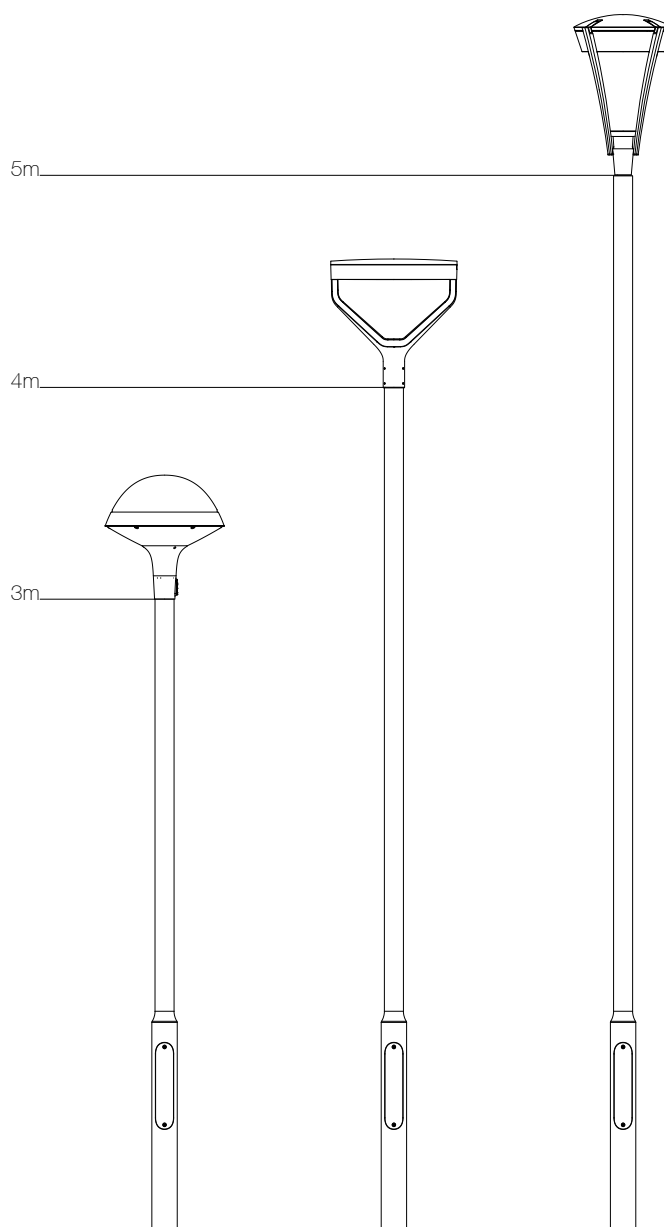



Dimensional Information

Planted Root Option: Supplied with bolt-on root

| Height (m) | BD (mm) | SD (mm) | PD (mm) | BD (mm) | SD (mm) | DH x DW (mm) | Mass (kg) | OTM (kNm) | Shear (kN) | Min. Concrete Dia. (mm) |
|------------|---------|---------|---------|---------|---------|--------------|-----------|-----------|------------|-------------------------|
| 3 | 150 | 90 | 800 | 1250 | 1750 | 500 x 95 | 14 | 4,45 | 1,50 | 468 |
| 3,5 | 150 | 90 | 800 | 1250 | 2250 | 500 x 95 | 15 | 4,47 | 1,34 | 459 |
| 4 | 150 | 90 | 800 | 1250 | 2750 | 500 x 95 | 16 | 4,45 | 1,27 | 449 |
| 4,5 | 150 | 90 | 800 | 1250 | 3250 | 500 x 95 | 18 | 4,42 | 1,23 | 440 |
| 5 | 150 | 90 | 800 | 1250 | 3750 | 500 x 95 | 19 | 4,45 | 1,20 | 439 |

Flange Plated Option

| Height (m) | BD (mm) | SD (mm) | BH (mm) | SH (mm) | DH x DW (mm) | SL x T x BC (mm) | Anchor Bolts | Mass (kg) | OTM (kNm) | Shear (kN) | Concrete Foundation Size (mm) |
|------------|---------|---------|---------|---------|--------------|------------------|--------------|-----------|-----------|------------|-------------------------------|
| 3 | 150 | 90 | 1250 | 1750 | 500 x 95 | 270 x 12 x 200 | M14/16 x 300 | 12 | 4,45 | 1,50 | 400 sq x 600 h |
| 3,5 | 150 | 90 | 1250 | 2250 | 500 x 95 | 270 x 12 x 200 | M14/16 x 300 | 13 | 4,47 | 1,34 | 400 sq x 600 h |
| 4 | 150 | 90 | 1250 | 2750 | 500 x 95 | 270 x 12 x 200 | M14/16 x 300 | 14 | 4,45 | 1,27 | 400 sq x 600 h |
| 4,5 | 150 | 90 | 1250 | 3250 | 500 x 95 | 270 x 12 x 200 | M14/16 x 300 | 16 | 4,42 | 1,23 | 400 sq x 600 h |
| 5 | 150 | 90 | 1250 | 3750 | 500 x 95 | 270 x 12 x 200 | M14/16 x 300 | 17 | 4,45 | 1,20 | 400 sq x 600 h |

Headload Capacity Information

| Height (m) | Mounting Arrangement | Projection (m) | Weight (kg) | Extra Light | Light | Medium | Heavy | Extra Heavy |
|------------|----------------------|----------------|-------------|-------------|-------|--------|-------|-------------|
| 3 | Post Top | N/A | 50 | 1,24 | 1,07 | 0,99 | 0,90 | 0,71 |
| | Post Top Side | N/A | 15 | 1,30 | 1,13 | 1,04 | 0,96 | 0,76 |
| 3,5 | Post Top | N/A | 50 | 0,98 | 0,84 | 0,77 | 0,70 | 0,55 |
| | Post Top Side | N/A | 15 | 1,07 | 0,93 | 0,86 | 0,78 | 0,62 |
| 4 | Post Top | N/A | 50 | 0,77 | 0,65 | 0,59 | 0,53 | 0,42 |
| | Post Top Side | N/A | 15 | 0,90 | 0,77 | 0,71 | 0,64 | 0,50 |
| 4,5 | Post Top | N/A | 50 | 0,59 | 0,50 | 0,45 | 0,41 | 0,30 |
| | Post Top Side | N/A | 15 | 0,75 | 0,64 | 0,58 | 0,52 | 0,41 |
| 5 | Post Top | N/A | 50 | 0,46 | 0,38 | 0,33 | 0,30 | 0,22 |
| | Post Top Side | N/A | 15 | 0,60 | 0,51 | 0,46 | 0,42 | 0,31 |

Dimensions and technical information given as an indication.

See diagrams beginning on page 308 for info regarding the moments and abbreviations used in above tables.

Valmont reserves the right to make, without delay and without prior notice, the technical or aesthetic modifications that it deems necessary to improve the products of the Standard Collection.

Conical Aluminium



Description

Aluminium lighting columns are manufactured using an extruding process then spun to form conical sections into which door openings and cable entry slots are cut. The columns are heat-treated by annealing in an oven and an anti-corrosion root treatment is applied resulting in a true seamless lightweight lighting structure. Columns are manufactured from AL6060-T5 with a naturally decorative brushed surface finishing to 120GR.

Specifications

Conical aluminium lighting columns are available in mounting heights from 4-12 metres.

These columns can be used for post top applications or supplied with demountable or integral bracket arm arrangements.

Valmont Stainton operates a Quality Assurance system which complies with requirements of BS EN ISO 9001.

Our welders and welding procedures are independently certified in accordance with EN ISO 9606 and EN ISO 15607.

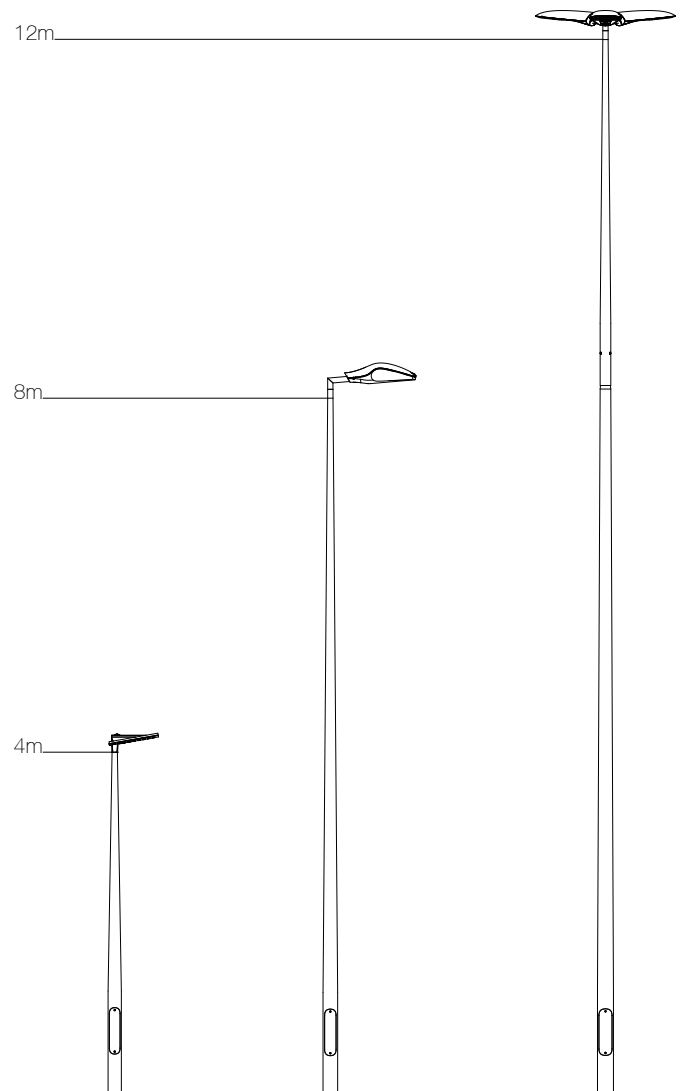



Dimensional Information

Planted Root Option

| Height (m) | BD (mm) | TD (mm) | PD (mm) | DH x DW (mm) | Mass (kg) | OTM (kNm) | Shear (kN) | Min. Concrete Dia. (mm) |
|------------|---------|---------|---------|--------------|-----------|-----------|------------|-------------------------|
| 4 | 150 | 76 | 800 | 500 x 100 | 44 | 3,52 | 1,14 | 426 |
| 5 | 150 | 76 | 800 | 500 x 100 | 49 | 4,46 | 1,23 | 527 |
| 6 | 150 | 76 | 1000 | 500 x 100 | 65 | 4,65 | 1,20 | 283 |
| 8 | 165 | 76 | 1200 | 600 x 115 | 88 | 7,27 | 1,53 | 253 |
| 10 | 200 | 76 | 1500 | 600 x 115 | 174 | 13,92 | 2,31 | 248 |
| 12 | 200 | 76 | 1700 | 600 x 115 | 220 | 17,54 | 2,63 | 213 |

Headload Capacity Information

| Height (m) | Mounting Arrangement | Projection (m) | Weight (kg) | Extra Light | Light | Medium | Heavy | Extra Heavy |
|------------|----------------------|----------------|-------------|-------------|-------|--------|-------|-------------|
| 4 | Post Top | N/A | 15 | 0,72 | 0,63 | 0,58 | 0,52 | 0,41 |
| | Post Top | N/A | 30 | 0,67 | 0,58 | 0,53 | 0,48 | 0,38 |
| 5 | Post Top | N/A | 15 | 0,67 | 0,57 | 0,52 | 0,47 | 0,36 |
| | Post Top | N/A | 30 | 0,61 | 0,52 | 0,47 | 0,43 | 0,33 |
| 6 | Post Top | N/A | 15 | 0,45 | 0,38 | 0,33 | 0,30 | 0,22 |
| | Post Top | N/A | 30 | 0,39 | 0,33 | 0,29 | 0,26 | 0,18 |
| 8 | Post Top | N/A | 15 | 0,27 | 0,22 | 0,19 | 0,17 | 0,12 |
| | Post Top | N/A | 30 | 0,23 | 0,18 | 0,16 | 0,13 | 0,09 |
| 10 | Post Top | N/A | 15 | 0,51 | 0,43 | 0,38 | 0,34 | 0,25 |
| | Post Top | N/A | 30 | 0,44 | 0,37 | 0,33 | 0,29 | 0,21 |
| 12 | Post Top | N/A | 15 | 0,38 | 0,31 | 0,28 | 0,24 | 0,16 |
| | Post Top | N/A | 30 | 0,32 | 0,26 | 0,22 | 0,19 | 0,12 |

Dimensions and technical information given as an indication.

See diagrams beginning on page 308 for info regarding the moments and abbreviations used in above tables.

Valmont reserves the right to make, without delay and without prior notice, the technical or aesthetic modifications that it deems necessary to improve the products of the Standard Collection.

Evolution



Description

Evolution is a simple interpretation of the plant theme, and should be thought of as a blade of grass. Symmetry can be created by repeating the same shape down the length of a path or roadway. In contrast, a more random or "natural" look can be created by modulating the columns. This modulation is similar to wind in the grass, and will result in playful and dynamic installation.

Specifications

Conical aluminium lighting columns are available in mounting heights from 6 to 10 metres.

Columns are manufactured from 6060T5 & T6 Brushed Aluminium and are formed with by cold bending. Lanterns are installed in a post top configuration.

Valmont Stainton operates a Quality Assurance system which complies with requirements of BS EN ISO 9001:2000.

Our welders and welding procedures are independently certified in accordance with EN ISO 9606 and EN ISO 15607.

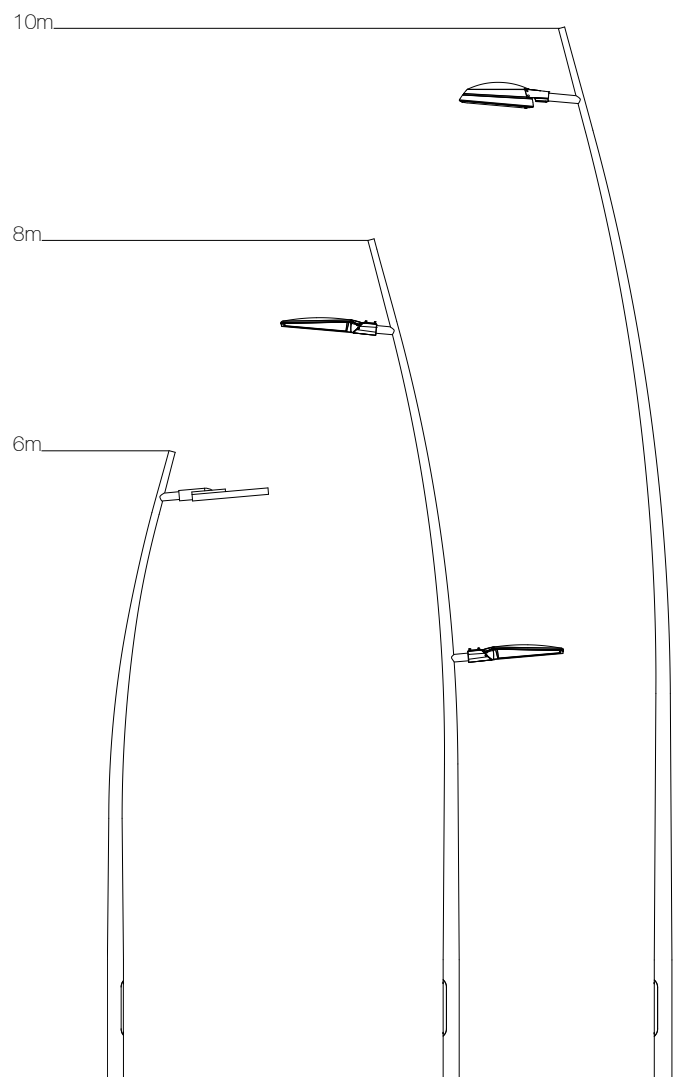



Dimensional Information

Planted Root Option: Supplied with bolt-on root

| Height (m) | BD (mm) | TD (mm) | PD (mm) | DH x DW (mm) | Mass (kg) | OTM (kNm) | Shear (kN) | Min. Concrete Dia. (mm) |
|------------|---------|---------|---------|--------------|-----------|-----------|------------|-------------------------|
| 6 | 150 | 60 | 1000 | 500 x 95 | 26,5 | 4,31 | 1,07 | 218 |
| 7 | 150 | 60 | 1200 | 500 x 95 | 40,5 | 7,66 | 1,55 | 225 |
| 8 | 150 | 60 | 1200 | 500 x 95 | 44,5 | 8,66 | 1,63 | 251 |
| 9 | 165 | 60 | 1500 | 500 x 100 | 59,5 | 12,08 | 1,89 | 181 |
| 10 | 165 | 60 | 1500 | 500 x 100 | 63,5 | 12,22 | 1,88 | 181 |

Flange Plated Option

| Height (m) | BD (mm) | TD (mm) | DH x DW (mm) | SL x T x BC (mm) | Anchor Bolts | Mass (kg) | OTM (kNm) | Shear (kN) | Concrete Foundation Size (mm) |
|------------|---------|---------|--------------|------------------|--------------|-----------|-----------|------------|-------------------------------|
| 6 | 150 | 60 | 500 x 95 | 270 x 12 x 200 | M14/16 x 300 | 24 | 4,31 | 1,07 | 400 sq x 600 h |
| 7 | 150 | 60 | 500 x 95 | 418 x 12 x 300 | M18/20 x 400 | 35 | 7,66 | 1,55 | 400 sq x 800 h |
| 8 | 150 | 60 | 500 x 95 | 418 x 12 x 300 | M18/20 x 400 | 39 | 8,66 | 1,63 | 400 sq x 800 h |
| 9 | 165 | 60 | 500 x 100 | 400 x 20 x 300 | M18/20 x 400 | 52 | 12,08 | 1,89 | 500 sq x 900 h |
| 10 | 165 | 60 | 500 x 100 | 400 x 20 x 300 | M18/20 x 400 | 56 | 12,22 | 1,88 | 500 sq x 900 h |

Headload Capacity Information

| Height (m) | Mounting Arrangement | Weight (kg) | Extra Light | Light | Medium | Heavy | Extra Heavy |
|------------|----------------------|-------------|-------------|-------|--------|-------|-------------|
| 6 | Post Top | 30 | 0,33 | 0,26 | 0,23 | 0,19 | 0,14 |
| | Post Top Side | 15 | 0,43 | 0,35 | 0,31 | 0,26 | 0,18 |
| 7 | Post Top | 30 | 0,58 | 0,49 | 0,44 | 0,39 | 0,29 |
| | Post Top Side | 15 | 0,55 | 0,46 | 0,42 | 0,37 | 0,29 |
| 8 | Post Top | 30 | 0,36 | 0,29 | 0,26 | 0,23 | 0,16 |
| | Post Top Side | 15 | 0,36 | 0,30 | 0,26 | 0,24 | 0,17 |
| 9 | Post Top | 40 | 0,44 | 0,37 | 0,32 | 0,29 | 0,19 |
| | Post Top Side | 15 | 0,50 | 0,42 | 0,38 | 0,33 | 0,25 |
| 10 | Post Top | 40 | 0,28 | 0,22 | 0,18 | 0,16 | 0,09 |
| | Post Top Side | 15 | 0,36 | 0,30 | 0,26 | 0,23 | 0,16 |

Dimensions and technical information given as an indication.

See diagrams beginning on page 308 for info regarding the moments and abbreviations used in above tables.

Valmont reserves the right to make, without delay and without prior notice, the technical or aesthetic modifications that it deems necessary to improve the products of the Standard Collection.

Candella



Description

Candlelight, and candlesticks are commonly used in the private sphere to create intimate and welcoming environments. We were inspired to bring this environment into the outdoors. This is how the Candella range was born.

Candella's layered base is a distant reminder of classic cast-iron masts. The shadows created by these curves enliven the column's silhouette and give it a strong visual presence.

Specifications

Spun aluminium lighting columns are available in mounting heights from 4 to 6 metres and suitable for post top lanterns.

Columns are manufactured from 6060T5 & T6 Brushed Aluminium then formed with by cold tapering. Spigot in AlSi7Mg Aluminium alloy.

Valmont Stainton operates a Quality Assurance system which complies with requirements of BS EN ISO 9001.

Our welders and welding procedures are independently certified in accordance with EN ISO 9606 and EN ISO 15607.

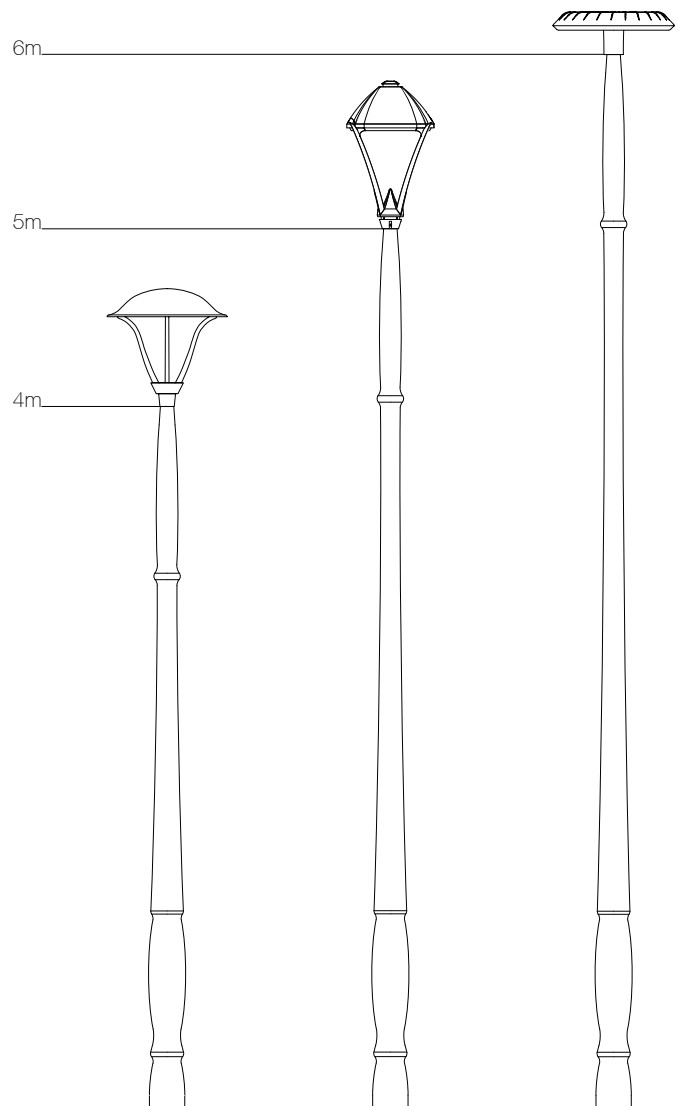



Dimensional Information

Planted Root Option: Supplied with bolt-on root

| Height (m) | BD (mm) | TD (mm) | PD (mm) | DH x DW (mm) | Mass (kg) | OTM (kNm) | Shear (kN) | Min. Concrete Dia. (mm) |
|------------|---------|---------|---------|--------------|-----------|-----------|------------|-------------------------|
| 4 | 200 | 76 | 800 | 450 x 120 | 25 | 6,24 | 1,66 | 630 |
| 5 | 200 | 76 | 800 | 450 x 120 | 30 | 6,17 | 1,50 | 607 |
| 6 | 200 | 76 | 1000 | 450 x 120 | 36 | 6,06 | 1,30 | 307 |

Flange Plated Option

| Height (m) | BD (mm) | TD (mm) | DH x DW (mm) | SL x T x BC (mm) | Anchor Bolts | Mass (kg) | OTM (kNm) | Shear (kN) | Concrete Foundation Size (mm) |
|------------|---------|---------|--------------|------------------|--------------|-----------|-----------|------------|-------------------------------|
| 4 | 200 | 76 | 450 x 120 | 400 x 15 x 300 | M18/20 x 400 | 24 | 6,24 | 1,66 | 400 sq x 700 h |
| 5 | 200 | 76 | 450 x 120 | 400 x 15 x 300 | M18/20 x 400 | 29 | 6,17 | 1,50 | 400 sq x 700 h |
| 6 | 200 | 76 | 450 x 120 | 400 x 15 x 300 | M18/20 x 400 | 34 | 6,06 | 1,30 | 400 sq x 700 h |

Headload Capacity Information

| Height (m) | Mounting Arrangement | Projection (m) | Weight (kg) | Extra Light | Light | Medium | Heavy | Extra Heavy |
|------------|----------------------|----------------|-------------|-------------|-------|--------|-------|-------------|
| 4 | Post Top | N/A | 50 | 1,31 | 1,14 | 1,05 | 0,96 | 0,76 |
| | Post Top Side | N/A | 15 | 1,16 | 1,01 | 0,93 | 0,85 | 0,67 |
| 5 | Post Top | N/A | 50 | 0,89 | 0,77 | 0,70 | 0,63 | 0,50 |
| | Post Top Side | N/A | 15 | 0,84 | 0,73 | 0,66 | 0,60 | 0,48 |
| 6 | Post Top | N/A | 30 | 0,64 | 0,55 | 0,50 | 0,44 | 0,33 |
| | Post Top Side | N/A | 15 | 0,59 | 0,51 | 0,46 | 0,42 | 0,32 |

Dimensions and technical information given as an indication.

See diagrams beginning on page 308 for info regarding the moments and abbreviations used in above tables.

Valmont reserves the right to make, without delay and without prior notice, the technical or aesthetic modifications that it deems necessary to improve the products of the Standard Collection.

Diva²



Description

The Diva² range owes its silhouette to the curves of the 70's and the figure-hugging mermaid dresses of the era.

The slimness at its base heightens the generous shapes halfway up and invites the eyes to take a stroll. This roundness is the only eccentric element of this column, which elsewhere plays on utter simplicity. This clean design communicates a sophisticated character, simple and timeless.

Specifications

Spun aluminium lighting columns are available in mounting heights from 4 to 6 metres and suitable for post top lanterns.

Columns are manufactured from 6060T5 & T6 Brushed Aluminium then formed with by cold tapering. Spigot in AlSi7Mg Aluminium alloy.

Valmont Stainton operates a Quality Assurance system which complies with requirements of BS EN ISO 9001.

Our welders and welding procedures are independently certified in accordance with EN ISO 9606 and EN ISO 15607.

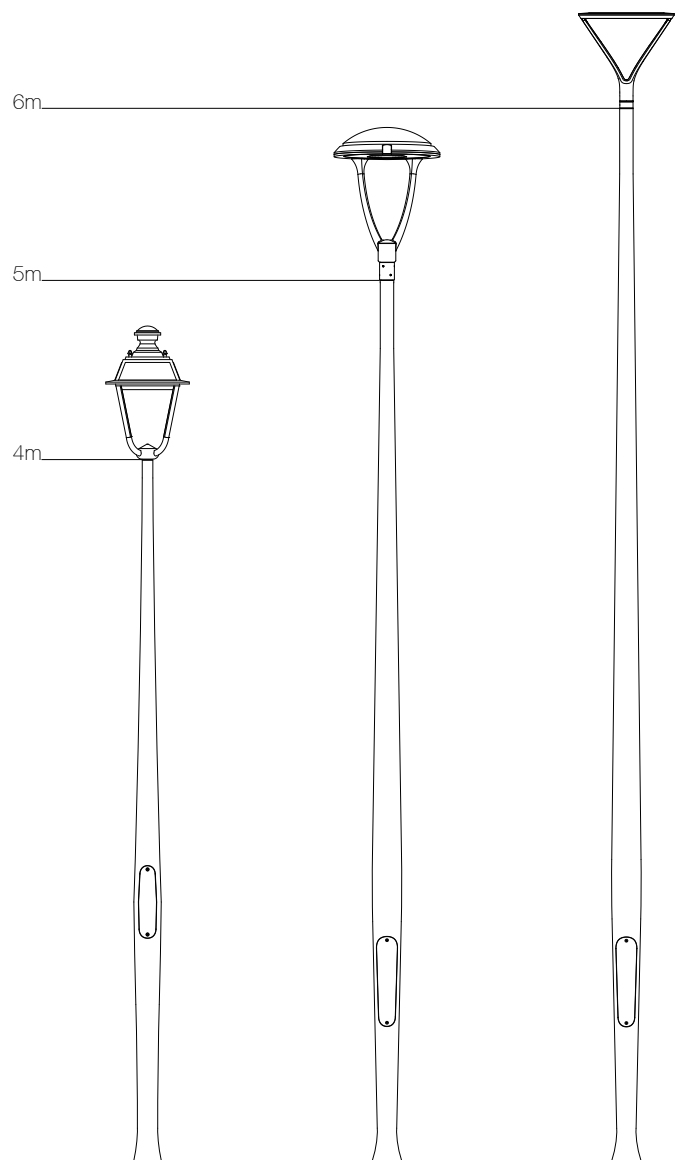



Dimensional Information

Planted Root Option: Supplied with bolt-on root

| Height (m) | BD (mm) | TD (mm) | PD (mm) | DH x DW (mm) | Mass (kg) | OTM (kNm) | Shear (kN) | Min. Concrete Dia. (mm) |
|------------|---------|---------|---------|--------------|-----------|-----------|------------|-------------------------|
| 4 | 165 | 60 | 800 | 400 x 75 | 19,5 | 6,86 | 1,82 | 692 |
| | 180 | 75 | 800 | 500 x 95 | 20,5 | 5,06 | 1,42 | 510 |
| 5 | 165 | 60 | 800 | 400 x 75 | 23,2 | 6,86 | 1,59 | 676 |
| | 180 | 75 | 800 | 500 x 95 | 23,5 | 4,96 | 1,27 | 488 |
| 6 | 165 | 60 | 1000 | 400 x 75 | 26,2 | 6,73 | 1,48 | 341 |
| | 180 | 75 | 1000 | 500 x 95 | 27,5 | 4,84 | 1,16 | 245 |

Flange Plated Option

| Height (m) | BD (mm) | TD (mm) | DH x DW (mm) | SL x T x BC (mm) | Anchor Bolts | Mass (kg) | OTM (kNm) | Shear (kN) | Concrete Foundation Size (mm) |
|------------|---------|---------|--------------|------------------|--------------|-----------|-----------|------------|-------------------------------|
| 4 | 165 | 60 | 400 x 75 | 270 x 20 x 200 | M14/16 x 300 | 18 | 6,86 | 1,82 | 400 sq x 700 h |
| | 180 | 76 | 500 x 95 | 270 x 20 x 200 | M14/16 x 300 | 19 | 5,06 | 1,42 | 400 sq x 600 h |
| 5 | 165 | 60 | 400 x 75 | 270 x 20 x 200 | M14/16 x 300 | 22 | 6,86 | 1,59 | 400 sq x 700 h |
| | 180 | 76 | 500 x 95 | 270 x 20 x 200 | M14/16 x 300 | 22 | 4,96 | 1,27 | 400 sq x 600 h |
| 6 | 165 | 60 | 400 x 75 | 270 x 20 x 200 | M14/16 x 300 | 25 | 6,73 | 1,48 | 400 sq x 700 h |
| | 180 | 76 | 500 x 95 | 270 x 20 x 200 | M14/16 x 300 | 26 | 4,84 | 1,16 | 400 sq x 600 h |

Headload Capacity Information

| Height (m) | BD (mm) | Mounting Arrangement | Weight (kg) | Extra Light | Light | Medium | Heavy | Extra Heavy |
|------------|---------|----------------------|-------------|-------------|-------|--------|-------|-------------|
| 4 | 165 | Post Top | 50 | 1,39 | 1,21 | 1,11 | 1,01 | 0,80 |
| | 180 | Post Top | 50 | 0,96 | 0,83 | 0,76 | 0,69 | 0,55 |
| 5 | 165 | Post Top | 50 | 0,96 | 0,83 | 0,75 | 0,67 | 0,53 |
| | 180 | Post Top | 50 | 0,60 | 0,51 | 0,46 | 0,42 | 0,32 |
| 6 | 165 | Post Top | 30 | 0,69 | 0,59 | 0,53 | 0,48 | 0,37 |
| | 180 | Post Top | 30 | 0,41 | 0,33 | 0,30 | 0,26 | 0,18 |

Dimensions and technical information given as an indication.

See diagrams beginning on page 308 for info regarding the moments and abbreviations used in above tables.

Valmont reserves the right to make, without delay and without prior notice, the technical or aesthetic modifications that it deems necessary to improve the products of the Standard Collection.

Idyline Courbe



Description

An exclusive concept for designing "bespoke" solutions from standard elements. The range consist of 9 elements which can be combined to create **489** unique lighting columns.

The Idyline range is 100% Aluminium, 30% of which are recycled materials.

Specifications

Modular aluminium lighting columns are available in heights from 5-8,6 metres.

These columns are supplied with an integral bracket arm.

Elements in 6060T5 & T6 Brushed Aluminium. Interfaces pieces in AlSi7Mg Aluminium alloy.

Valmont Stainton operates a Quality Assurance system which complies with requirements of BS EN ISO 9001.

Our welders and welding procedures are independently certified in accordance with EN ISO 9606 and EN ISO 15607.

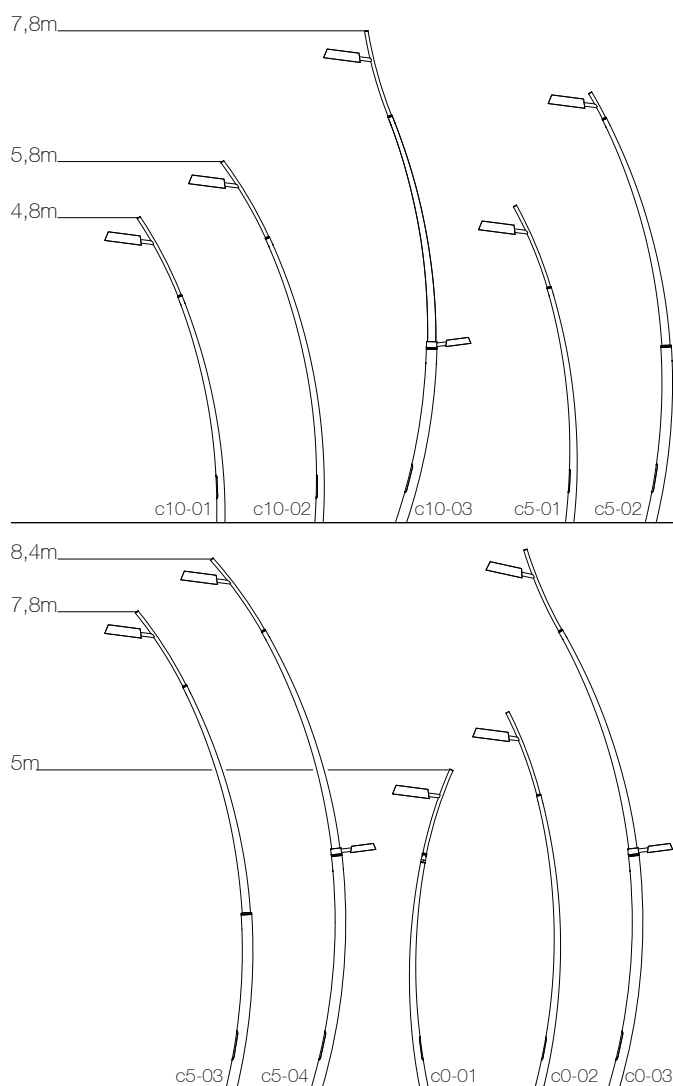



Dimensional Information

Planted Root Option: Supplied with bolt-on root

| Column | Height (m) | BD (mm) | TD (mm) | PD (mm) | DH x DW (mm) | Mass (kg) | OTM (kNm) | Shear (kN) | Min. Concrete Dia. (mm) |
|--------|------------|---------|---------|---------|--------------|-----------|-----------|------------|-------------------------|
| C0-01 | 5,0 | 140 | 60 | 800 | 400 x 75 | 20,3 | 4,01 | 1,06 | 395 |
| C0-02 | 6,0 | 140 | 60 | 1000 | 400 x 75 | 24,1 | 3,09 | 0,96 | - |
| C0-03 | 8,5 | 180 | 60 | 1500 | 500 x 100 | 57,5 | 3,07 | 0,96 | - |
| C5-01 | 5,0 | 140 | 60 | 800 | 400 x 75 | 20,3 | 4,10 | 1,08 | 403 |
| C5-02 | 7,0 | 180 | 60 | 1200 | 500 x 100 | 45,0 | 3,35 | 1,01 | - |
| C5-03 | 7,8 | 180 | 60 | 1200 | 500 x 100 | 48,0 | 3,17 | 0,98 | - |
| C5-04 | 8,6 | 180 | 60 | 1500 | 500 x 100 | 57,5 | 3,30 | 0,98 | - |
| C10-01 | 4,8 | 140 | 60 | 800 | 400 x 75 | 20,3 | 3,03 | 0,91 | 300 |
| C10-02 | 5,8 | 140 | 60 | 1000 | 400 x 75 | 24,3 | 3,74 | 0,98 | 190 |
| C10-03 | 7,8 | 180 | 60 | 1200 | 500 x 100 | 48,0 | 6,99 | 1,48 | 203 |

Flange Plated Option

| Column | Height (m) | BD (mm) | TD (mm) | DH x DW (mm) | SL x T x BC (mm) | Anchor Bolts | Mass (kg) | OTM (kNm) | Shear (kN) | Concrete Foundation Size (mm) |
|--------|------------|---------|---------|--------------|------------------|--------------|-----------|-----------|------------|-------------------------------|
| C0-01 | 5,0 | 140 | 60 | 400 x 75 | 270 x 15 x 200 | M14/16 x 300 | 19 | 4,01 | 1,06 | 400 sq x 500 h |
| C0-02 | 6,0 | 140 | 60 | 400 x 75 | 270 x 15 x 200 | M14/16 x 300 | 22 | 3,09 | 0,96 | 400 sq x 500 h |
| C0-03 | 8,5 | 180 | 60 | 500 x 100 | 400 x 20 x 300 | M18/20 x 400 | 53 | 3,07 | 0,96 | 400 sq x 500 h |
| C5-01 | 5,0 | 140 | 60 | 400 x 75 | 270 x 15 x 200 | M14/16 x 300 | 19 | 4,10 | 1,08 | 400 sq x 500 h |
| C5-02 | 7,0 | 180 | 60 | 500 x 100 | 400 x 20 x 300 | M18/20 x 400 | 43 | 3,35 | 1,01 | 400 sq x 500 h |
| C5-03 | 7,8 | 180 | 60 | 500 x 100 | 400 x 20 x 300 | M18/20 x 400 | 46 | 3,17 | 0,98 | 400 sq x 500 h |
| C5-04 | 8,6 | 180 | 60 | 500 x 100 | 400 x 20 x 300 | M18/20 x 400 | 53 | 3,30 | 0,98 | 400 sq x 500 h |
| C10-01 | 4,8 | 140 | 60 | 400 x 75 | 270 x 15 x 200 | M14/16 x 300 | 19 | 3,03 | 0,91 | 400 sq x 500 h |
| C10-02 | 5,8 | 140 | 60 | 400 x 75 | 270 x 15 x 200 | M14/16 x 300 | 22 | 3,74 | 0,98 | 400 sq x 500 h |
| C10-03 | 7,8 | 180 | 60 | 500 x 100 | 400 x 20 x 300 | M18/20 x 400 | 46 | 6,99 | 1,48 | 400 sq x 700 h |

Headload Capacity Information

| Column | Height (m) | Mounting Arrangement | Projection (m) | Weight (kg) | Extra Light | Light | Medium | Heavy | Extra Heavy |
|--------|------------|----------------------|----------------|-------------|-------------|-------|--------|-------|-------------|
| C0-01 | 5,0 | Post Top Side | 0 | 15 | 0,55 | 0,44 | 0,39 | 0,35 | 0,24 |
| C0-02 | 6,0 | Post Top Side | 0,5 | 15 | 0,14 | 0,10 | 0,08 | 0,05 | 0,02 |
| C0-03 | 8,5 | Post Top Side | 2,3 | 15 | 0,11 | 0,07 | 0,04 | 0,03 | 0,00 |
| C5-01 | 5,0 | Post Top Side | 0,9 | 15 | 0,30 | 0,25 | 0,22 | 0,19 | 0,12 |
| C5-02 | 7,0 | Post Top Side | 1,1 | 15 | 0,53 | 0,44 | 0,39 | 0,36 | 0,26 |
| C5-03 | 7,8 | Post Top Side | 1,5 | 15 | 0,21 | 0,16 | 0,14 | 0,11 | 0,07 |
| C5-04 | 8,6 | Post Top Side | 1,6 | 15 | 0,11 | 0,08 | 0,05 | 0,03 | 0,00 |
| C10-01 | 4,8 | Post Top Side | 1,4 | 15 | 0,29 | 0,24 | 0,21 | 0,18 | 0,12 |
| C10-02 | 5,8 | Post Top Side | 1,6 | 15 | 0,11 | 0,08 | 0,05 | 0,04 | 0,00 |
| C10-03 | 7,8 | Post Top Side | 0,7 | 15 | 0,24 | 0,19 | 0,17 | 0,14 | 0,09 |

Dimensions and technical information given as an indication.

See diagrams beginning on page 308 for info regarding the moments and abbreviations used in above tables.

Valmont reserves the right to make, without delay and without prior notice, the technical or aesthetic modifications that it deems necessary to improve the products of the Standard Collection.



Description

An exclusive concept for designing "bespoke" solutions from standard elements. The range consist of 9 elements which can be combined to create **489** unique lighting columns.

The Idyline range is 100% Aluminium, 30% of which are recycled materials.

Specifications

Modular aluminium lighting columns are available in heights from 5-9 metres.

These columns are supplied with an integral bracket arm.

Elements in 6060T5 & T6 Brushed Aluminium. Interfaces pieces in AlSi7Mg Aluminium alloy.

Valmont Stainton operates a Quality Assurance system which complies with requirements of BS EN ISO 9001.

Our welders and welding procedures are independently certified in accordance with EN ISO 9606 and EN ISO 15607.

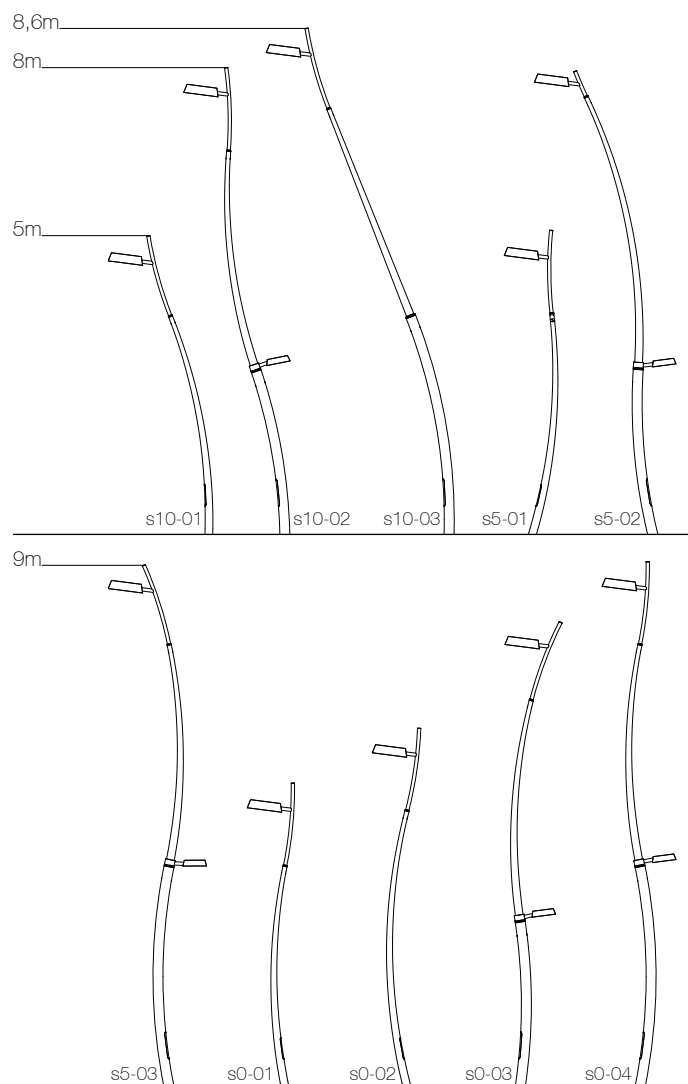



Dimensional Information

Planted Root Option: Supplied with bolt-on root

| Column | Height (m) | BD (mm) | TD (mm) | PD (mm) | DH x DW (mm) | Mass (kg) | OTM (kNm) | Shear (kN) | Min. Concrete Dia. (mm) |
|--------|------------|---------|---------|---------|--------------|-----------|-----------|------------|-------------------------|
| S0-01 | 5,0 | 140 | 60 | 800 | 400 x 75 | 20,3 | 7,09 | 1,53 | 698 |
| S0-02 | 6,0 | 140 | 60 | 1000 | 400 x 75 | 24,1 | 7,52 | 1,58 | 381 |
| S0-03 | 8,0 | 180 | 60 | 1200 | 500 x 100 | 48,0 | 8,76 | 1,71 | 254 |
| S0-04 | 9,0 | 180 | 60 | 1500 | 500 x 100 | 57,2 | 7,57 | 1,58 | - |
| S5-01 | 5,0 | 140 | 60 | 800 | 400 x 75 | 20,3 | 7,72 | 1,59 | 760 |
| S5-02 | 7,8 | 180 | 60 | 1200 | 500 x 100 | 48,0 | 7,10 | 1,42 | 206 |
| S5-03 | 9,0 | 180 | 60 | 1500 | 500 x 100 | 57,2 | 7,12 | 1,42 | - |
| S10-01 | 5,0 | 140 | 60 | 800 | 400 x 75 | 20,3 | 9,05 | 1,71 | 891 |
| S10-02 | 8,0 | 180 | 60 | 1200 | 500 x 100 | 48,0 | 9,14 | 1,62 | 265 |
| S10-03 | 8,6 | 180 | 60 | 1500 | 500 x 100 | 57,5 | 7,86 | 1,61 | - |

Flange Plated Option

| Column | Height (m) | BD (mm) | TD (mm) | DH x DW (mm) | SL x T x BC (mm) | Anchor Bolts | Mass (kg) | OTM (kNm) | Shear (kN) | Concrete Foundation Size (mm) |
|--------|------------|---------|---------|--------------|------------------|--------------|-----------|-----------|------------|-------------------------------|
| S0-01 | 5,0 | 140 | 60 | 400 x 75 | 270 x 15 x 200 | M14/16 x 300 | 19 | 7,09 | 1,53 | 400 sq x 700 h |
| S0-02 | 6,0 | 140 | 60 | 400 x 75 | 270 x 15 x 200 | M14/16 x 300 | 22 | 7,52 | 1,58 | 400 sq x 700 h |
| S0-03 | 8,0 | 180 | 60 | 500 x 100 | 400 x 20 x 300 | M18/20 x 400 | 46 | 8,76 | 1,71 | 400 sq x 800 h |
| S0-04 | 9,0 | 180 | 60 | 500 x 100 | 400 x 20 x 300 | M18/20 x 400 | 53 | 7,57 | 1,58 | 400 sq x 700 h |
| S5-01 | 5,0 | 140 | 60 | 400 x 75 | 270 x 15 x 200 | M14/16 x 300 | 19 | 7,72 | 1,59 | 400 sq x 800 h |
| S5-02 | 7,8 | 180 | 60 | 500 x 100 | 400 x 20 x 300 | M18/20 x 400 | 46 | 7,10 | 1,42 | 400 sq x 700 h |
| S5-03 | 9,0 | 180 | 60 | 500 x 100 | 400 x 20 x 300 | M18/20 x 400 | 53 | 7,12 | 1,42 | 400 sq x 700 h |
| S10-01 | 5,0 | 140 | 60 | 400 x 75 | 270 x 15 x 200 | M14/16 x 300 | 19 | 9,05 | 1,71 | 400 sq x 800 h |
| S10-02 | 8,0 | 180 | 60 | 500 x 100 | 400 x 20 x 300 | M18/20 x 400 | 46 | 9,14 | 1,62 | 400 sq x 800 h |
| S10-03 | 8,6 | 180 | 60 | 500 x 100 | 400 x 20 x 300 | M18/20 x 400 | 53 | 7,86 | 1,61 | 400 sq x 800 h |

Headload Capacity Information

| Column | Height (m) | Mounting Arrangement | Projection (m) | Weight (kg) | Extra Light | Light | Medium | Heavy | Extra Heavy |
|--------|------------|----------------------|----------------|-------------|-------------|-------|--------|-------|-------------|
| S0-01 | 5,0 | Post Top Side | 0 | 15 | 0,56 | 0,45 | 0,41 | 0,36 | 0,24 |
| S0-02 | 6,0 | Post Top Side | 0 | 15 | 0,26 | 0,21 | 0,16 | 0,12 | 0,05 |
| S0-03 | 8,0 | Post Top Side | 0 | 15 | 0,41 | 0,33 | 0,29 | 0,25 | 0,16 |
| S0-04 | 9,0 | Post Top Side | 0 | 15 | 0,28 | 0,21 | 0,17 | 0,14 | 0,07 |
| S5-01 | 5,0 | Post Top Side | 0 | 15 | 0,36 | 0,30 | 0,26 | 0,23 | 0,16 |
| S5-02 | 7,8 | Post Top Side | 1,4 | 15 | 0,26 | 0,21 | 0,18 | 0,15 | 0,09 |
| S5-03 | 9,0 | Post Top Side | 1,3 | 15 | 0,26 | 0,21 | 0,18 | 0,15 | 0,07 |
| S10-01 | 5,0 | Post Top Side | 1,2 | 15 | 0,32 | 0,26 | 0,23 | 0,21 | 0,14 |
| S10-02 | 8,0 | Post Top Side | 1,2 | 15 | 0,28 | 0,22 | 0,19 | 0,16 | 0,10 |
| S10-03 | 8,6 | Post Top Side | 2,7 | 15 | 0,17 | 0,12 | 0,10 | 0,08 | 0,02 |

Dimensions and technical information given as an indication.

See diagrams beginning on page 308 for info regarding the moments and abbreviations used in above tables.

Valmont reserves the right to make, without delay and without prior notice, the technical or aesthetic modifications that it deems necessary to improve the products of the Standard Collection.

Sillem



Description

Inspired by Nature and more particularly by trees, Sillem offers a modular design structured around 3 Branches, 1 Knot, and 1 Trunk. In combination, these 5 components yield 15 unique designs!

This modular approach makes it possible to optimise the product with regards to the geometric variations of the spaces to be developed. You are able to choose the most appropriate shape to fit the exact needs of the location, whilst maintaining continuity of line throughout the project.

Specifications

Modular aluminium lighting columns are available in mounting heights from 4.6 to 9.5 metres.

The Sillem range is 100% Aluminium, 30% of which is recycled material. The Branches and Trunk are 6060T5 Brushed Aluminium. The Knot is AlSi7Mg Aluminium alloy.

Valmont Stainton operates a Quality Assurance system which complies with requirements of BS EN ISO 9001.

Our welders and welding procedures are independently certified in accordance with EN ISO 9606 and EN ISO 15607.

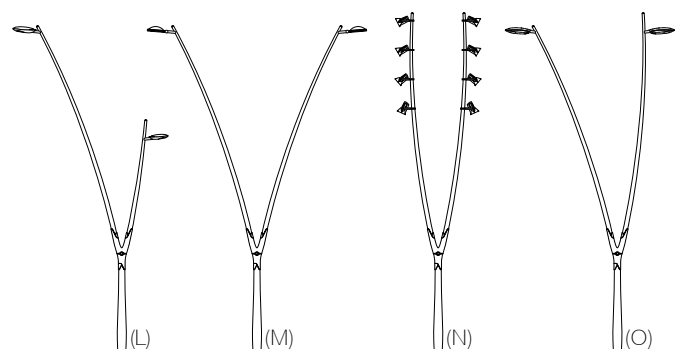
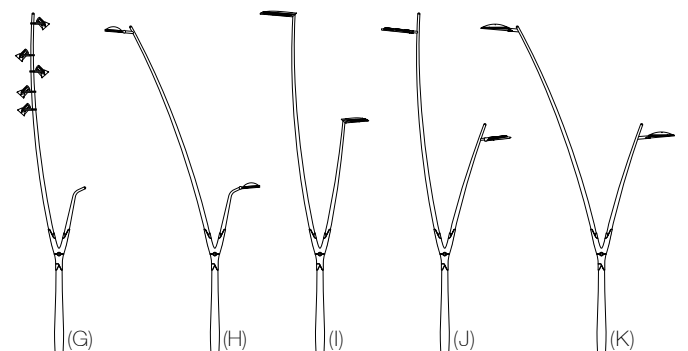
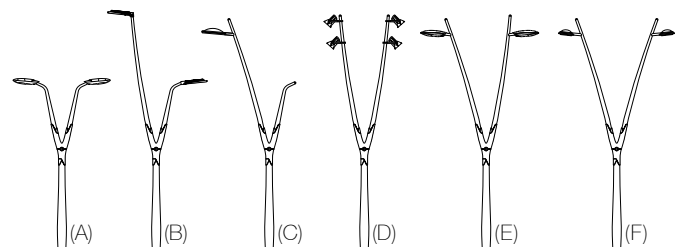



Dimensional Information

Planted Root Option: Supplied with bolt-on root

| Column | Height (m) | BD (mm) | TD (mm) | PD (mm) | DH x DW (mm) | Mass (kg) | OTM (kNm) | Shear (kN) | Min. Concrete Dia. (mm) |
|--------|------------|---------|---------|---------|--------------|-----------|-----------|------------|-------------------------|
| A | 4,6 / 4,6 | 220 | 60 | 800 | 500 x 130 | 78,0 | 15,04 | 3,53 | 1494 |
| B | 6,5 / 4,6 | 220 | 60 | 1200 | 500 x 130 | 86,0 | 15,02 | 3,21 | 445 |
| C | 6,5 / 4,6 | 220 | 60 | 1200 | 500 x 130 | 86,0 | 14,93 | 3,20 | 443 |
| D | 6,5 / 6,5 | 220 | 60 | 1200 | 500 x 130 | 90,0 | 15,03 | 2,94 | 445 |
| E | 6,4 / 6,5 | 220 | 60 | 1200 | 500 x 130 | 90,0 | 14,97 | 3,12 | 444 |
| F | 6,4 / 6,4 | 220 | 60 | 1200 | 500 x 130 | 90,0 | 15,06 | 2,95 | 467 |
| G | 9,5 / 4,6 | 220 | 60 | 1500 | 500 x 130 | 98,5 | 18,13 | 3,45 | 270 |
| H | 9,2 / 4,6 | 220 | 60 | 1500 | 500 x 130 | 97,5 | 16,01 | 3,12 | 240 |
| I | 9,5 / 6,5 | 220 | 60 | 1500 | 500 x 130 | 102,5 | 18,48 | 3,13 | 276 |
| J | 9,5 / 6,4 | 220 | 60 | 1500 | 500 x 130 | 102,5 | 18,70 | 3,16 | 279 |
| K | 9,2 / 6,4 | 220 | 60 | 1500 | 500 x 130 | 102,5 | 17,09 | 3,09 | 256 |
| L | 9,2 / 6,5 | 220 | 60 | 1500 | 500 x 130 | 102,5 | 16,95 | 3,03 | 254 |
| M | 9,2 / 9,2 | 220 | 60 | 1500 | 500 x 130 | 111,5 | 19,09 | 3,30 | 286 |
| N | 9,5 / 9,5 | 220 | 60 | 1500 | 500 x 130 | 111,5 | 19,05 | 3,17 | 284 |
| O | 9,2 / 9,5 | 220 | 60 | 1500 | 500 x 130 | 111,5 | 18,07 | 3,09 | 270 |

Flange Plated Option

| Column | Height (m) | BD (mm) | TD (mm) | DH x DW (mm) | SL x T x BC (mm) | Anchor Bolts | Mass (kg) | OTM (kNm) | Shear (kN) | Concrete Foundation Size (mm) |
|--------|------------|---------|---------|--------------|------------------|--------------|-----------|-----------|------------|-------------------------------|
| A | 4,6 / 4,6 | 220 | 60 | 500 x 130 | 400 x 20 x 300 | M18/20 x 400 | 76 | 15,04 | 3,53 | 500 sq x 1000 h |
| B | 6,5 / 4,6 | 220 | 60 | 500 x 130 | 400 x 20 x 300 | M18/20 x 400 | 80 | 15,02 | 3,21 | 500 sq x 1000 h |
| C | 6,5 / 4,6 | 220 | 60 | 500 x 130 | 400 x 20 x 300 | M18/20 x 400 | 80 | 14,93 | 3,20 | 500 sq x 1000 h |
| D | 6,5 / 6,5 | 220 | 60 | 500 x 130 | 400 x 20 x 300 | M18/20 x 400 | 84 | 15,03 | 2,94 | 500 sq x 1000 h |
| E | 6,4 / 6,5 | 220 | 60 | 500 x 130 | 400 x 20 x 300 | M18/20 x 400 | 84 | 14,97 | 3,12 | 500 sq x 1000 h |
| F | 6,4 / 6,4 | 220 | 60 | 500 x 130 | 400 x 20 x 300 | M18/20 x 400 | 84 | 15,06 | 2,95 | 500 sq x 1000 h |
| G | 9,5 / 4,6 | 220 | 60 | 500 x 130 | 400 x 25 x 300 | M18/20 x 400 | 90 | 18,13 | 3,45 | 600 sq x 1100 h |
| H | 9,2 / 4,6 | 220 | 60 | 500 x 130 | 400 x 25 x 300 | M18/20 x 400 | 89 | 16,01 | 3,12 | 600 sq x 1000 h |
| I | 9,5 / 6,5 | 220 | 60 | 500 x 130 | 400 x 25 x 300 | M18/20 x 400 | 94 | 18,48 | 3,13 | 600 sq x 1100 h |
| J | 9,5 / 6,4 | 220 | 60 | 500 x 130 | 400 x 25 x 300 | M18/20 x 400 | 94 | 18,70 | 3,16 | 600 sq x 1100 h |
| K | 9,2 / 6,4 | 220 | 60 | 500 x 130 | 400 x 25 x 300 | M18/20 x 400 | 94 | 17,09 | 3,09 | 600 sq x 1100 h |
| L | 9,2 / 6,5 | 220 | 60 | 500 x 130 | 400 x 25 x 300 | M18/20 x 400 | 94 | 16,95 | 3,03 | 600 sq x 1000 h |
| M | 9,2 / 9,2 | 220 | 60 | 500 x 130 | 400 x 25 x 300 | M18/20 x 400 | 103 | 19,09 | 3,30 | 600 sq x 1100 h |
| N | 9,5 / 9,5 | 220 | 60 | 500 x 130 | 400 x 25 x 300 | M18/20 x 400 | 103 | 19,05 | 3,17 | 600 sq x 1100 h |
| O | 9,2 / 9,5 | 220 | 60 | 500 x 130 | 400 x 25 x 300 | M18/20 x 400 | 103 | 18,07 | 3,09 | 600 sq x 1100 h |

Headload Capacity Information

| Height (m) | Mounting Arrangement | Projection (m) | Weight (kg) | Extra Light | Light | Medium | Heavy | Extra Heavy |
|------------|----------------------|----------------|-------------|-------------|-------|--------|-------|-------------|
| 4,6 / 4,6 | Double Arm | 0,7 / 0,7 | 15 | 1,60 | 1,39 | 1,27 | 1,16 | 0,91 |
| 6,5 / 4,6 | Double Arm | 0,7 / 0,7 | 15 | 1,23 | 1,06 | 0,97 | 0,87 | 0,67 |
| 6,5 / 4,6 | Double Arm | 1,1 / 0,7 | 15 | 1,21 | 1,05 | 0,96 | 0,86 | 0,66 |
| 6,5 / 6,5 | Double Arm | 0,7 / 0,7 | 15 | 0,96 | 0,82 | 0,73 | 0,66 | 0,50 |
| 6,4 / 6,5 | Double Arm | 1,1 / 0,7 | 15 | 0,94 | 0,80 | 0,73 | 0,65 | 0,50 |
| 6,4 / 6,4 | Double Arm | 1,1 / 1,1 | 15 | 0,96 | 0,82 | 0,73 | 0,66 | 0,50 |
| 9,5 / 4,6 | Double Arm | 0,8 / 0,7 | 15 | 0,48 | 0,39 | 0,35 | 0,30 | 0,21 |
| 9,2 / 4,6 | Double Arm | 2,4 / 0,7 | 15 | 0,42 | 0,33 | 0,29 | 0,25 | 0,17 |
| 9,5 / 6,5 | Double Arm | 0,8 / 0,7 | 15 | 0,45 | 0,36 | 0,31 | 0,26 | 0,17 |
| 9,5 / 6,4 | Double Arm | 0,8 / 1,1 | 15 | 0,46 | 0,37 | 0,32 | 0,28 | 0,18 |
| 9,2 / 6,4 | Double Arm | 2,4 / 1,1 | 15 | 0,37 | 0,29 | 0,25 | 0,21 | 0,12 |
| 9,2 / 6,5 | Double Arm | 2,4 / 1,1 | 15 | 0,36 | 0,29 | 0,24 | 0,21 | 0,12 |
| 9,2 / 9,2 | Double Arm | 2,4 / 2,4 | 15 | 0,23 | 0,16 | 0,12 | 0,10 | 0,03 |
| 9,5 / 9,5 | Double Arm | 0,8 / 0,8 | 15 | 0,24 | 0,17 | 0,14 | 0,10 | 0,03 |
| 9,2 / 9,5 | Double Arm | 2,4 / 0,8 | 15 | 0,21 | 0,14 | 0,11 | 0,08 | 0,01 |

Dimensions and technical information given as an indication.

See diagrams beginning on page 308 for info regarding the moments and abbreviations used in above tables.

Valmont reserves the right to make, without delay and without prior notice, the technical or aesthetic modifications that it deems necessary to improve the products of the Standard Collection.

Annapurna



Description

The strong visual lines of the bracket in combination with the sleek contours of the column provide a formal framework which helps to add structure to traffic lanes.

To soften this overall look, the masts are detailed with three small points at the junction of the pole and the bracket. This simple design language is borrowed from traditional cutlery and adds a sense of sophistication to the product.

Specifications

Conical aluminium lighting columns are available in mounting heights from 4-10 metres. Suitable for post top applications or supplied with demountable bracket arm arrangement.

The range is 100% Aluminium, 30% of which is recycled. The mast is 6060T5 Brushed Aluminium while the bracket is AlSi7Mg Aluminium alloy.

Valmont Stainton operates a Quality Assurance system which complies with requirements of BS EN ISO 9001. Our welders and welding procedures are independently certified in accordance with EN ISO 9606 and EN ISO 15607.

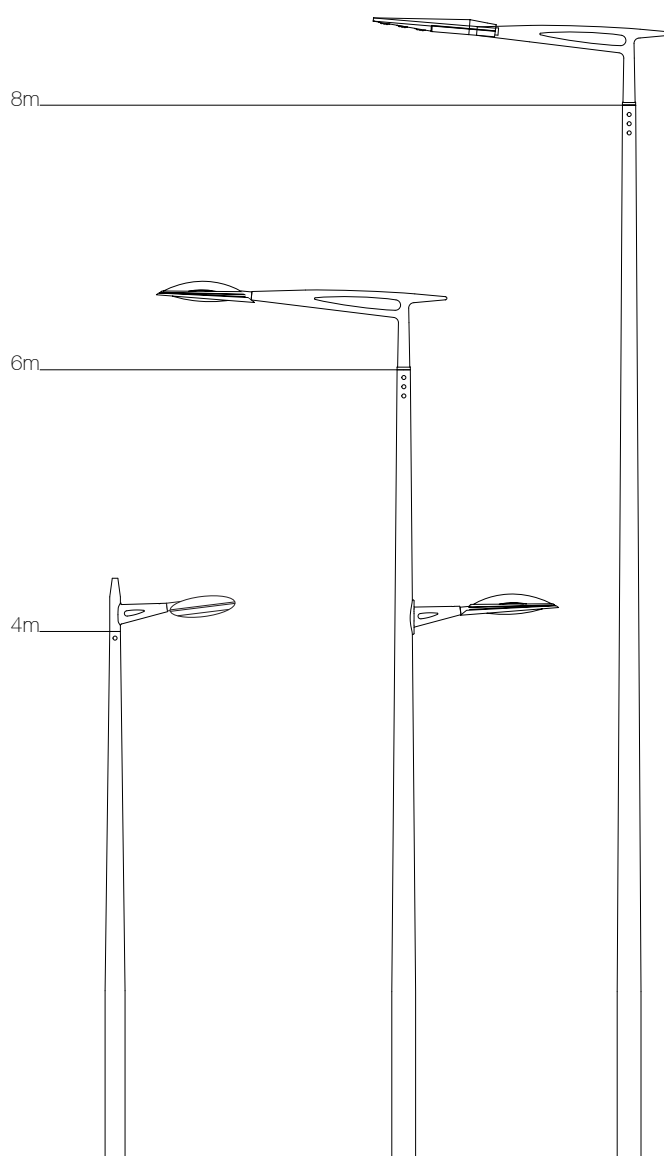



Dimensional Information

Planted Root Option: Supplied with bolt-on root

| Height (m) | BD (mm) | TD (mm) | PD (mm) | DH x DW (mm) | Mass (kg) | OTM (kNm) | Shear (kN) | Min. Concrete Dia. (mm) |
|------------|---------|---------|---------|--------------|-----------|-----------|------------|-------------------------|
| 4 | 150 | 80 | 800 | 500 x 95 | 22 | 4,48 | 1,30 | 452 |
| 5 | 150 | 80 | 800 | 500 x 95 | 25 | 5,18 | 1,29 | 510 |
| 6 | 150 | 80 | 1000 | 500 x 95 | 39 | 9,96 | 1,93 | 504 |
| | 180 | 100 | 1000 | 500 x 120 | 57 | 16,42 | 2,84 | 831 |
| 7 | 180 | 100 | 1200 | 500 x 120 | 64 | 16,47 | 2,55 | 484 |
| 8 | 180 | 100 | 1200 | 500 x 120 | 69 | 16,47 | 2,37 | 478 |
| 9 | 180 | 100 | 1500 | 500 x 120 | 74 | 14,30 | 2,21 | 214 |
| | 200 | 100 | 1500 | 500 x 120 | 101 | 25,07 | 3,16 | 376 |
| 10 | 180 | 100 | 1500 | 500 x 120 | 78 | 15,18 | 2,25 | 225 |
| | 200 | 100 | 1500 | 500 x 120 | 107 | 25,02 | 3,07 | 371 |

Flange Plated Option

| Height (m) | BD (mm) | TD (mm) | DH x DW (mm) | SL x T x BC (mm) | Anchor Bolts | Mass (kg) | OTM (kNm) | Shear (kN) | Concrete Foundation Size (mm) |
|------------|---------|---------|--------------|------------------|--------------|-----------|-----------|------------|-------------------------------|
| 4 | 150 | 80 | 500 x 95 | 270 x 12 x 200 | M14/16 x 300 | 20 | 4,48 | 1,30 | 400 sq x 600 h |
| 5 | 150 | 80 | 500 x 95 | 270 x 15 x 200 | M14/16 x 300 | 23 | 5,18 | 1,29 | 400 sq x 600 h |
| 6 | 150 | 80 | 500 x 95 | 270 x 20 x 200 | M14/16 x 300 | 32 | 9,96 | 1,93 | 500 sq x 800 h |
| | 180 | 100 | 500 x 120 | 418 x 15 x 300 | M18/20 x 400 | 50 | 16,42 | 2,84 | 600 sq x 1000 h |
| 7 | 180 | 100 | 500 x 120 | 418 x 15 x 300 | M18/20 x 400 | 54 | 16,47 | 2,55 | 500 sq x 1000 h |
| 8 | 180 | 100 | 500 x 120 | 418 x 15 x 300 | M18/20 x 400 | 59 | 16,47 | 2,37 | 500 sq x 1000 h |
| 9 | 180 | 100 | 500 x 120 | 418 x 15 x 300 | M18/20 x 400 | 61 | 14,30 | 2,21 | 500 sq x 1000 h |
| | 200 | 100 | 500 x 120 | 400 x 30 x 300 | M18/20 x 400 | 86 | 25,07 | 3,16 | 600 sq x 1200 h |
| 10 | 180 | 100 | 500 x 120 | 418 x 15 x 300 | M18/20 x 400 | 65 | 15,18 | 2,25 | 500 sq x 1000 h |
| | 200 | 100 | 500 x 120 | 400 x 30 x 300 | M18/20 x 400 | 92 | 25,02 | 3,07 | 600 sq x 1200 h |

Headload Capacity Information

| Height (m) | Mounting Arrangement | Projection (m) | Weight (kg) | Extra Light | Light | Medium | Heavy | Extra Heavy |
|------------|----------------------|----------------|-------------|-------------|-------|--------|-------|-------------|
| 4 | Single Arm | 0,4 | 15 | 0,75 | 0,64 | 0,58 | 0,52 | 0,41 |
| | Double Arm | 0,4 | 15 | 0,35 | 0,29 | 0,25 | 0,22 | 0,16 |
| 5 | Single Arm | 0,4 | 15 | 0,56 | 0,48 | 0,42 | 0,37 | 0,26 |
| | Double Arm | 0,4 | 15 | 0,26 | 0,21 | 0,18 | 0,15 | 0,09 |
| 6 | Single Arm | 0,4 | 15 | 0,35 | 0,28 | 0,23 | 0,19 | 0,11 |
| | Double Arm | 0,4 | 15 | 0,52 | 0,43 | 0,38 | 0,33 | 0,24 |
| | Single Arm | 1,2 | 15 | 0,85 | 0,73 | 0,66 | 0,60 | 0,46 |
| | Double Arm | 1,2 | 15 | 0,93 | 0,80 | 0,72 | 0,65 | 0,49 |
| 7 | Single Arm | 1,2 | 15 | 0,76 | 0,65 | 0,58 | 0,52 | 0,39 |
| | Double Arm | 1,2 | 15 | 0,70 | 0,59 | 0,52 | 0,46 | 0,33 |
| 8 | Single Arm | 1,2 | 15 | 0,42 | 0,36 | 0,31 | 0,28 | 0,19 |
| | Double Arm | 1,2 | 15 | 0,31 | 0,24 | 0,21 | 0,18 | 0,10 |
| 9 | Single Arm | 1,2 | 15 | 0,33 | 0,28 | 0,24 | 0,19 | 0,11 |
| | Double Arm | 1,2 | 15 | 0,52 | 0,44 | 0,38 | 0,33 | 0,23 |
| 10 | Single Arm | 1,2 | 15 | 0,22 | 0,16 | 0,12 | 0,09 | 0,03 |
| | Double Arm | 1,2 | 15 | 0,37 | 0,30 | 0,26 | 0,23 | 0,14 |

Dimensions and technical information given as an indication.

See diagrams beginning on page 308 for info regarding the moments and abbreviations used in above tables.

Valmont reserves the right to make, without delay and without prior notice, the technical or aesthetic modifications that it deems necessary to improve the products of the Standard Collection.

Ceedji



Description

A careful balance between negative space and solid forms give the design of this bracket a timeless presence and helps it fit seamlessly into the spirit of any project.

Specifications

Steel, Aluminium, and Wooden columns can all be used in combination with this decorative bracket. Recommended mounting heights between 5 and 8 metres.

Ceedji is manufactured from AISi7Mg Aluminium alloy and is available in both single and double configurations with outreaches of 0.8 and 1.2 metres.

Pedestrian and wall brackets are also available.

Valmont Stainton operates a Quality Assurance system which complies with requirements of BS EN ISO 9001.

Our welders and welding procedures are independently certified in accordance with EN ISO 9606 and EN ISO 15607.

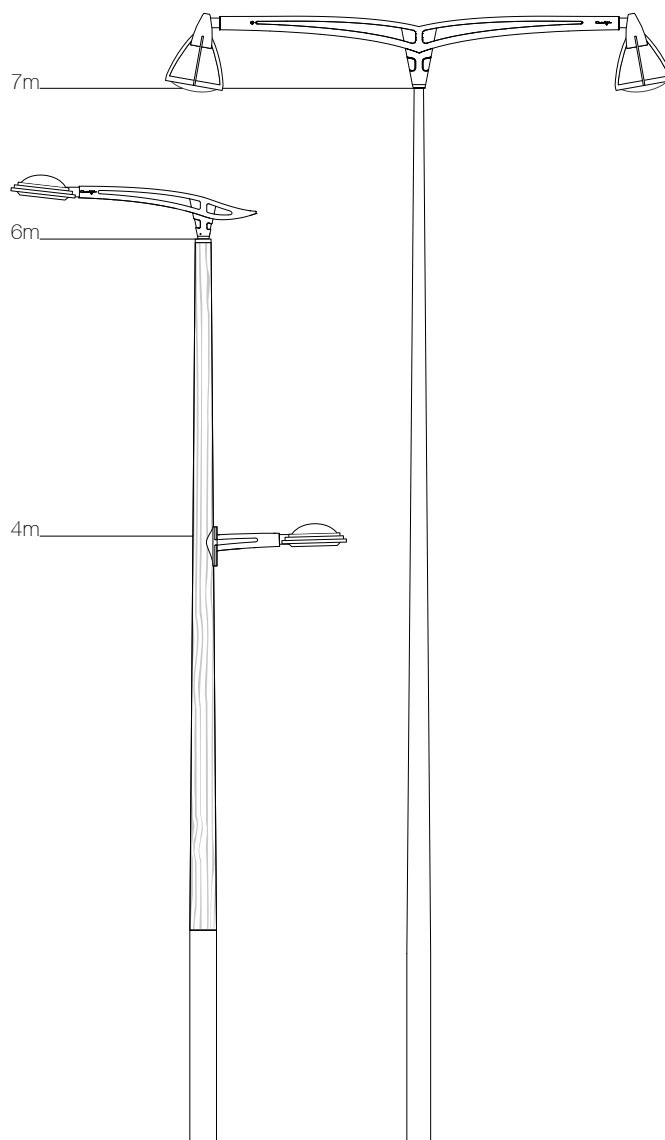



Dimensional Information

Planted Root Option: Supplied with bolt-on root

| Height (m) | BD (mm) | TD (mm) | PD (mm) | DH x DW (mm) | Mass (kg) | OTM (kNm) | Shear (kN) | Min. Concrete Dia. (mm) |
|------------|---------|---------|---------|--------------|-----------|-----------|------------|-------------------------|
| 5 | 150 | 60 | 800 | 500 x 95 | 28 | 4,45 | 1,16 | 438 |
| | 150 RF | 60 | 800 | 500 x 95 | 36 | 9,95 | 2,17 | 980 |
| 6 | 150 | 60 | 1000 | 500 x 95 | 41 | 9,84 | 1,90 | 498 |
| 7 | 150 RF | 60 | 1200 | 500 x 95 | 46 | 9,95 | 1,83 | 293 |
| | 165 RF | 60 | 1200 | 500 x 100 | 52 | 13,06 | 2,20 | 384 |
| 8 | 165 RF | 60 | 1200 | 500 x 100 | 55 | 13,10 | 2,09 | 380 |
| | 180 RF | 120 | 1200 | 500 x 120 | 62 | 16,41 | 2,46 | 476 |

*RF indicates a reinforced base section.

Flange Plated Option

| Height (m) | BD (mm) | TD (mm) | DH x DW (mm) | SL x T x BC (mm) | Anchor Bolts | Mass (kg) | OTM (kNm) | Shear (kN) | Concrete Foundation Size (mm) |
|------------|---------|---------|--------------|------------------|--------------|-----------|-----------|------------|-------------------------------|
| 5 | 150 | 60 | 500 x 95 | 270 x 12 x 200 | M14/16 x 300 | 26 | 4,45 | 1,16 | 400 sq x 600 h |
| | 150 RF | 60 | 500 x 95 | 418 x 12 x 300 | M18/20 x 400 | 34 | 9,95 | 2,17 | 500 sq x 800 h |
| 6 | 150 | 60 | 500 x 95 | 418 x 12 x 300 | M18/20 x 400 | 37 | 9,84 | 1,90 | 500 sq x 800 h |
| 7 | 150 RF | 60 | 500 x 95 | 418 x 12 x 300 | M18/20 x 400 | 40 | 9,95 | 1,83 | 500 sq x 800 h |
| | 165 RF | 60 | 500 x 100 | 400 x 20 x 300 | M18/20 x 400 | 48 | 13,06 | 2,20 | 500 sq x 900 h |
| 8 | 165 RF | 60 | 500 x 100 | 400 x 20 x 300 | M18/20 x 400 | 51 | 13,10 | 2,09 | 500 sq x 900 h |
| | 180 RF | 120 | 500 x 120 | 418 x 15 x 300 | M18/20 x 400 | 54 | 16,41 | 2,46 | 500 sq x 1000 h |

*RF indicates a reinforced base section.

Headload Capacity Information

| Height (m) | BD (mm) | Mounting Arrangement | Projection (m) | Weight (kg) | Extra Light | Light | Medium | Heavy | Extra Heavy |
|------------|---------|----------------------|----------------|-------------|-------------|-------|--------|-------|-------------|
| 5 | 150 | Single Arm | 0,8 | 15 | 0,29 | 0,23 | 0,21 | 0,17 | 0,11 |
| | | Double Arm | 0,8 | 15 | 0,18 | 0,15 | 0,12 | 0,10 | 0,04 |
| | 150 RF | Single Arm | 0,8 | 15 | 0,56 | 0,49 | 0,44 | 0,39 | 0,30 |
| | | Double Arm | 0,8 | 15 | 0,72 | 0,62 | 0,56 | 0,5 | 0,37 |
| 6 | 150 | Single Arm | 0,8 | 15 | 0,46 | 0,39 | 0,36 | 0,32 | 0,23 |
| | | Single Arm | 0,8 | 15 | 0,5 | 0,42 | 0,37 | 0,32 | 0,23 |
| | 150 RF | Double Arm | 0,8 | 15 | 0,36 | 0,3 | 0,26 | 0,23 | 0,16 |
| | | Single Arm | 0,8 | 15 | 0,33 | 0,28 | 0,24 | 0,21 | 0,12 |
| 7 | 165 RF | Double Arm | 0,8 | 15 | 0,62 | 0,53 | 0,49 | 0,45 | 0,33 |
| | | Single Arm | 0,8 | 15 | 0,57 | 0,48 | 0,43 | 0,37 | 0,26 |
| | 165 RF | Double Arm | 0,8 | 15 | 0,36 | 0,3 | 0,26 | 0,23 | 0,16 |
| | | Single Arm | 0,8 | 15 | 0,25 | 0,19 | 0,17 | 0,14 | 0,08 |
| 8 | 180 RF | Double Arm | 0,8 | 15 | 0,43 | 0,38 | 0,35 | 0,31 | 0,23 |
| | | Single Arm | 0,8 | 15 | 0,41 | 0,33 | 0,29 | 0,25 | 0,17 |

*RF indicates a reinforced base section.

Dimensions and technical information given as an indication.

See diagrams beginning on page 308 for info regarding the moments and abbreviations used in above tables.

Valmont reserves the right to make, without delay and without prior notice, the technical or aesthetic modifications that it deems necessary to improve the products of the Standard Collection.

Wooden Columns Standard and Bespoke

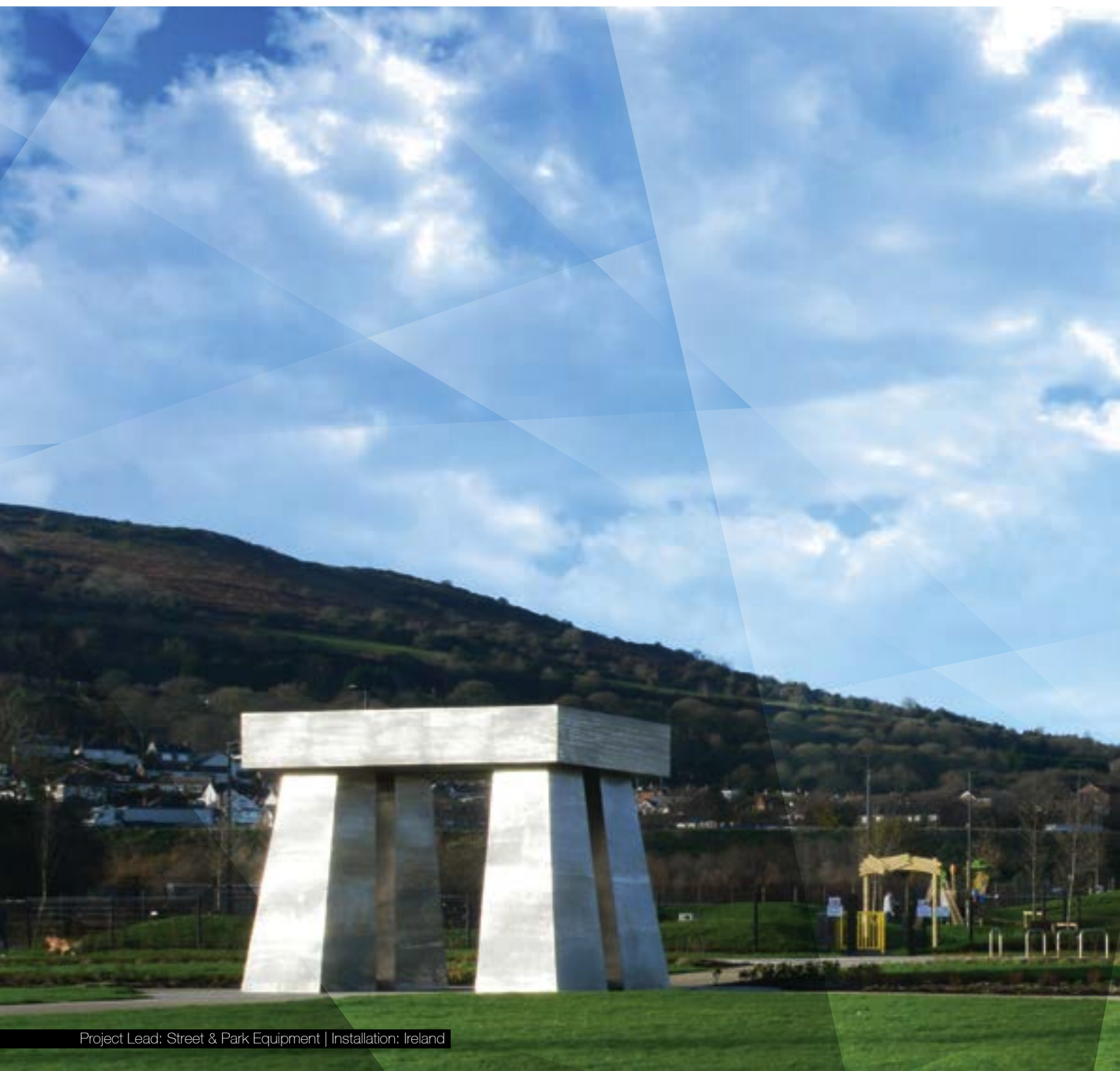

Project Lead: Street & Park Equipment | Installation: Ireland

Glulam 

- Pallas
- Inari
- Koli
- Ruka
- Ontelo
- Laine
- Seka
- Kartio
- Bespoke



Pallas_{Park}



Description

Pallas Park is a light duty version of the standard Pallas range of conical wooden lighting columns. Pallas Park is suitable for city centres and pedestrian areas.

The simple conical profile of the Pallas range adds a touch of sophistication while the natural material offers a warmth and richness that is extremely difficult to duplicate with metallic lighting columns.

Specifications

All shafts are manufactured from GL28h glued-laminated timber. The raw materials we use are harvested from sustainably managed, PEFC certified forests.

All wood is treated with a water-based stain finish consisting of four protective coats, VOCs <100g/l.

Cylindrical base and flush pole cap, in hot dip galvanised and powder coated S235 steel.

The range is designed and developed according to Eurocode 5, standards ISO EN40 and ISO EN1995.

A ZEP contract for CO₂ compensation is available.

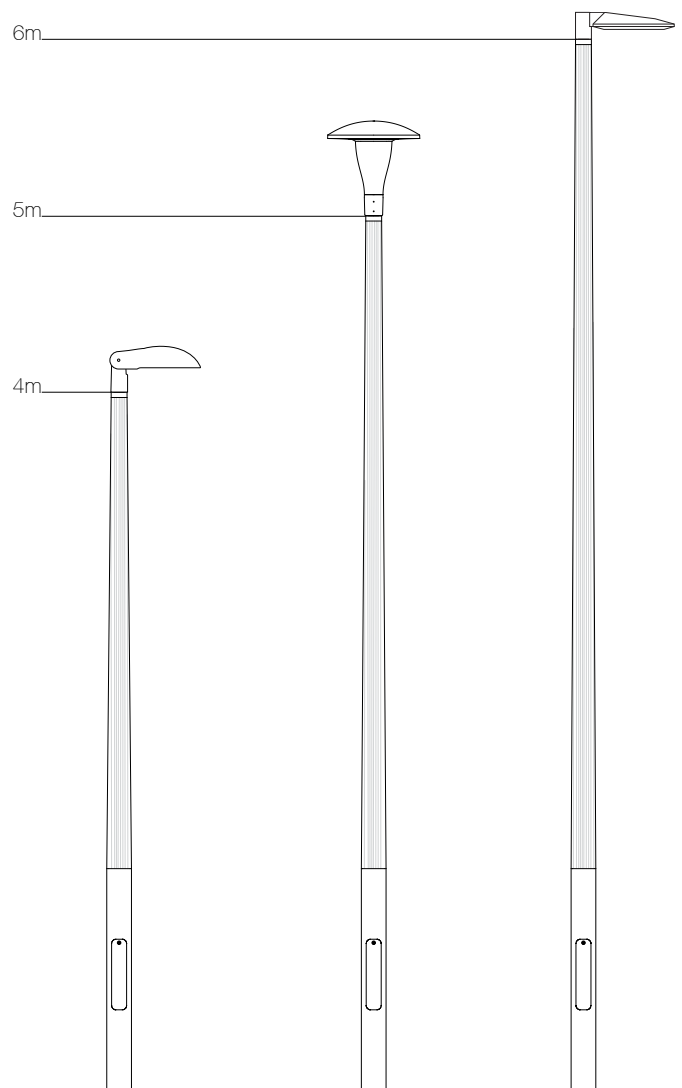



Dimensional Information

Planted Root Option

| Height (m) | BD (mm) | BH (m) | TD (mm) | WH (m) | PD (mm) | DH x DW (mm)h | Mass (kg) | OTM (kNm) | Shear (kN) | Min. Concrete Dia. (mm) |
|------------|---------|--------|---------|--------|---------|---------------|-----------|-----------|------------|-------------------------|
| 4 | 140 | 1,4 | 90 | 2,6 | 800 | 500 x 100 | 38 | 6,45 | 1,66 | 652 |
| 5 | 140 | 1,4 | 90 | 3,6 | 800 | 500 x 100 | 41 | 6,11 | 1,42 | 601 |
| 6 | 140 | 1,4 | 90 | 4,6 | 1000 | 500 x 100 | 47,5 | 5,89 | 1,27 | 298 |

Flange Plated Option

| Height (m) | BD (mm) | BH (m) | TD (mm) | WH (m) | DH x DW (mm) | SL x T x BC (mm) | Anchor Bolts | Mass (kg) | OTM (kNm) | Shear (kN) | Concrete Foundation Size (mm) |
|------------|---------|--------|---------|--------|--------------|------------------|--------------|-----------|-----------|------------|-------------------------------|
| 4 | 140 | 1,4 | 90 | 2,6 | 500 x 100 | 270 x 12 x 200 | M14/16 x 300 | 33,5 | 6,45 | 1,66 | 400 sq x 700 h |
| 5 | 140 | 1,4 | 90 | 3,6 | 500 x 100 | 270 x 12 x 200 | M14/16 x 300 | 36,5 | 6,11 | 1,42 | 400 sq x 700 h |
| 6 | 140 | 1,4 | 90 | 4,6 | 500 x 100 | 270 x 12 x 200 | M14/16 x 300 | 40,5 | 5,89 | 1,27 | 400 sq x 700 h |

Headload Capacity Information

| Height (m) | Mounting Arrangement | Projection (m ²) | Weight (kg) | Extra Light | Light | Medium | Heavy | Extra Heavy |
|------------|----------------------|------------------------------|-------------|-------------|-------|--------|-------|-------------|
| 4 | Post Top | N/A | 50 | 1,40 | 1,23 | 1,12 | 1,03 | 0,82 |
| 5 | Post Top | N/A | 50 | 0,89 | 0,77 | 0,70 | 0,64 | 0,50 |
| 6 | Post Top | N/A | 30 | 0,62 | 0,53 | 0,48 | 0,43 | 0,32 |



Dimensions and technical information given as an indication.

See diagrams beginning on page 308 for info regarding the moments and abbreviations used in above tables.

Valmont reserves the right to make, without delay and without prior notice, the technical or aesthetic modifications that it deems necessary to improve the products of the Standard Collection.

Pallas



Description

Pallas is a range of conical wooden lighting columns which is suitable for city centres, parks and street lighting.

The simple conical profile of the Pallas range adds a touch of sophistication while the natural material offers a warmth and richness that is extremely difficult to duplicate with metallic lighting columns.

Specifications

All shafts are manufactured from GL28h glued-laminated timber. The raw materials we use are harvested from sustainably managed, PEFC certified forests.

All wood is treated with a water-based stain finish consisting of four protective coats, VOCs <100g/l.

Cylindrical base and flush pole cap, in hot dip galvanised and powder coated S235 steel.

The range is designed and developed according to Eurocode 5, standards ISO EN40 and ISO EN1995.

A ZEP contract for CO₂ compensation is available.

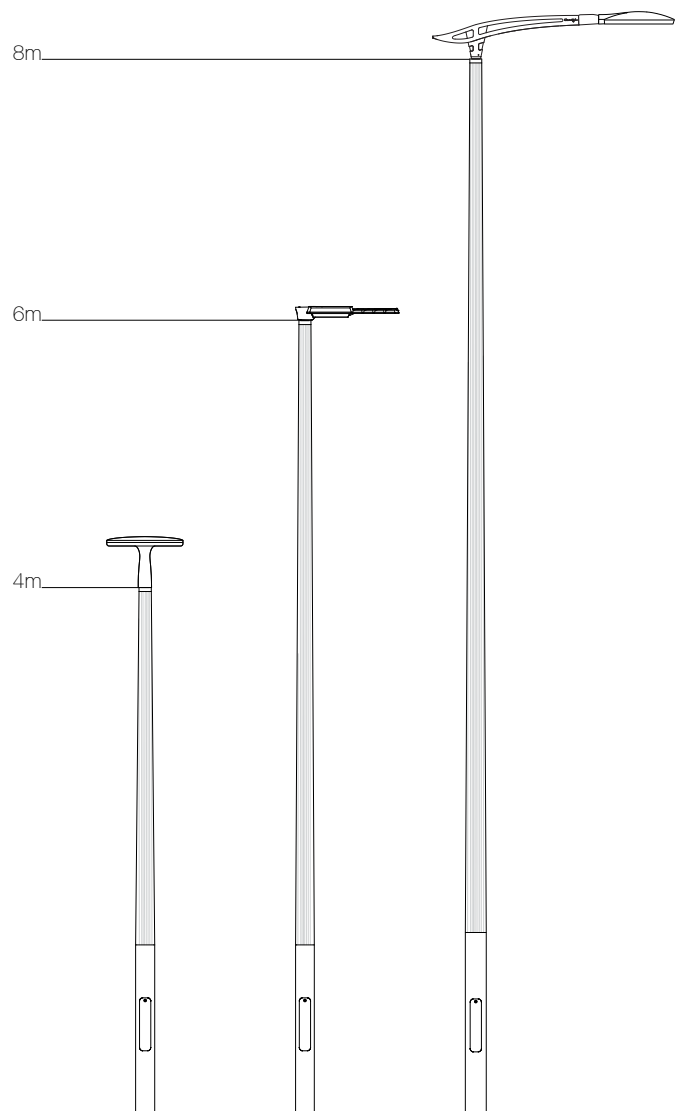



Dimensional Information

Planted Root Option

| Height (m) | BD (mm) | BH (m) | TD (mm) | WH (m) | PD (mm) | DH x DW (mm)h | Mass (kg) | OTM (kNm) | Shear (kN) | Min. Concrete Dia. (mm) |
|------------|---------|--------|---------|--------|---------|---------------|-----------|-----------|------------|-------------------------|
| 4 | 168 | 1,5 | 100 | 2,5 | 800 | 500 x 100 | 53,0 | 11,84 | 2,86 | 1195 |
| 5 | 168 | 1,5 | 100 | 3,5 | 800 | 500 x 100 | 59,0 | 10,98 | 2,30 | 1081 |
| 6 | 168 | 1,5 | 100 | 4,5 | 1000 | 500 x 100 | 67,5 | 10,52 | 1,98 | 533 |
| 8 | 193 | 1,7 | 100 | 6,3 | 1200 | 600 x 115 | 103,5 | 15,94 | 2,47 | 462 |

Flange Plated Option

| Height (m) | BD (mm) | BH (m) | TD (mm) | WH (m) | DH x DW (mm) | SL x T x BC (mm) | Anchor Bolts | Mass (kg) | OTM (kNm) | Shear (kN) | Concrete Foundation Size (mm) |
|------------|---------|--------|---------|--------|--------------|------------------|--------------|-----------|-----------|------------|-------------------------------|
| 4 | 168 | 1,5 | 100 | 2,5 | 500 x 100 | 270 x 12 x 200 | M14/16 x 300 | 44,5 | 11,84 | 2,86 | 500 sq x 900 h |
| 5 | 168 | 1,5 | 100 | 3,5 | 500 x 100 | 270 x 12 x 200 | M14/16 x 300 | 50,5 | 10,98 | 2,30 | 500 sq x 900 h |
| 6 | 168 | 1,5 | 100 | 4,5 | 500 x 100 | 270 x 12 x 200 | M14/16 x 300 | 56,0 | 10,52 | 1,98 | 500 sq x 800 h |
| 8 | 193 | 1,7 | 100 | 6,3 | 600 x 115 | 400 x 15 x 300 | M18/20 x 400 | 95,5 | 15,94 | 2,47 | 500 sq x 1000 h |

Headload Capacity Information

| Height (m) | Mounting Arrangement | Projection (m ²) | Weight (kg) | Extra Light | Light | Medium | Heavy | Extra Heavy |
|------------|----------------------|------------------------------|-------------|-------------|-------|--------|-------|-------------|
| 4 | Post Top | N/A | 50 | 2,94 | 2,58 | 2,39 | 2,20 | 1,78 |
| | Single Arm | 0,5 | 15 | 0,91 | 0,80 | 0,73 | 0,67 | 0,55 |
| | Single Arm | 1,0 | 15 | 0,51 | 0,44 | 0,41 | 0,37 | 0,29 |
| 5 | Post Top | N/A | 50 | 2,00 | 1,75 | 1,61 | 1,48 | 1,19 |
| | Single Arm | 0,5 | 15 | 0,78 | 0,69 | 0,64 | 0,58 | 0,46 |
| | Single Arm | 1,0 | 15 | 0,43 | 0,38 | 0,35 | 0,31 | 0,24 |
| 6 | Post Top | N/A | 30 | 1,51 | 1,32 | 1,21 | 1,11 | 0,89 |
| | Single Arm | 0,5 | 15 | 0,71 | 0,63 | 0,57 | 0,52 | 0,42 |
| | Single Arm | 1,0 | 15 | 0,39 | 0,33 | 0,31 | 0,28 | 0,22 |
| 8 | Post Top | N/A | 30 | 1,14 | 1,00 | 0,92 | 0,84 | 0,66 |
| | Single Arm | 0,5 | 15 | 0,45 | 0,39 | 0,36 | 0,33 | 0,26 |
| | Single Arm | 1,0 | 15 | 0,24 | 0,21 | 0,18 | 0,17 | 0,12 |



Dimensions and technical information given as an indication.

See diagrams beginning on page 308 for info regarding the moments and abbreviations used in above tables.

Valmont reserves the right to make, without delay and without prior notice, the technical or aesthetic modifications that it deems necessary to improve the products of the Standard Collection.



Description

Inari Park is a light duty version of the standard Inari range of cylindrical wooden columns. The Inari Park range is suitable for city centres and pedestrian areas.

The Inari range of wooden columns offers a robust look with a natural feel. This versatile column is well suited for both contemporary and historic applications and is sure to make a positive impact.

Specifications

All shafts are manufactured from GL28h glued-laminated timber. The raw materials we use are harvested from sustainably managed, PEFC certified forests.

All wood is treated with a water-based stain finish consisting of four protective coats, VOCs <100g/l.

Cylindrical base and flush pole cap, in hot dip galvanised and powder coated S235 steel.

The range is designed and developed according to Eurocode 5, standards ISO EN40 and ISO EN1995.

A ZEP contract for CO₂ compensation is available.

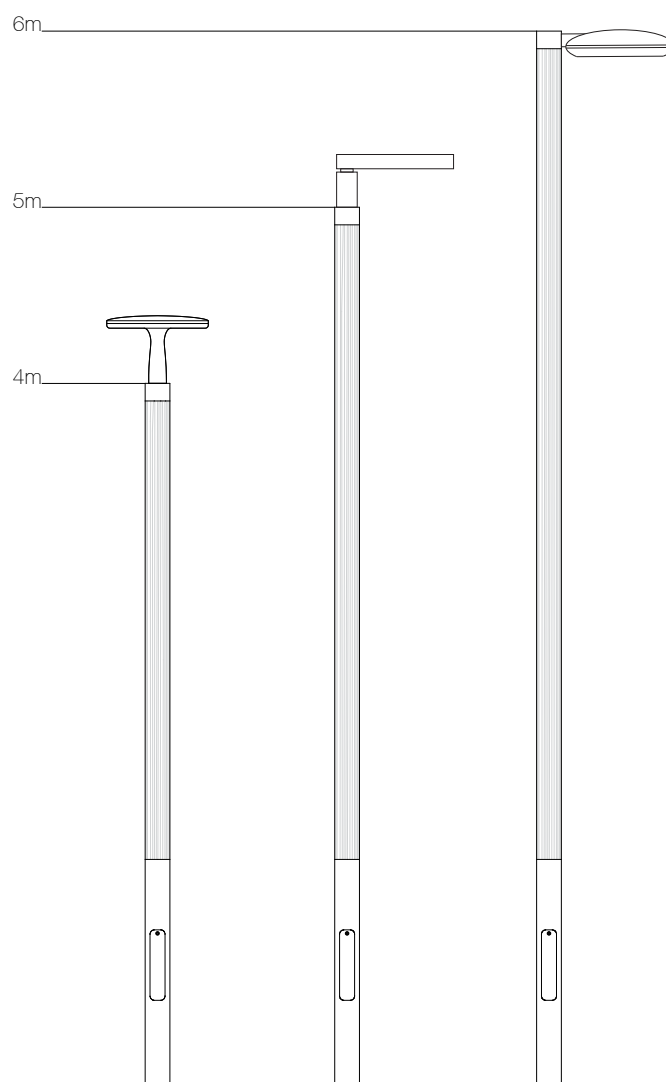



Dimensional Information

Planted Root Option

| Height (m) | BD (mm) | BH (m) | TD (mm) | WH (m) | PD (mm) | DH x DW (mm)h | Mass (kg) | OTM (kNm) | Shear (kN) | Min. Concrete Dia. (mm) |
|------------|---------|--------|---------|--------|---------|---------------|-----------|-----------|------------|-------------------------|
| 4 | 140 | 1,4 | 140 | 2,6 | 800 | 500 x 100 | 43 | 6,46 | 1,66 | 652 |
| 5 | 140 | 1,4 | 140 | 3,6 | 800 | 500 x 100 | 49 | 6,08 | 1,40 | 599 |
| 6 | 140 | 1,4 | 140 | 4,6 | 1000 | 500 x 100 | 59 | 5,87 | 1,26 | 297 |

Flange Plated Option

| Height (m) | BD (mm) | BH (m) | TD (mm) | WH (m) | DH x DW (mm) | SL x T x BC (mm) | Anchor Bolts | Mass (kg) | OTM (kNm) | Shear (kN) | Concrete Foundation Size (mm) |
|------------|---------|--------|---------|--------|--------------|------------------|--------------|-----------|-----------|------------|-------------------------------|
| 4 | 140 | 1,4 | 140 | 2,6 | 500 x 100 | 270 x 12 x 200 | M14/16 x 300 | 38,5 | 6,46 | 1,66 | 400 sq x 700 h |
| 5 | 140 | 1,4 | 140 | 3,6 | 500 x 100 | 270 x 12 x 200 | M14/16 x 300 | 44,5 | 6,08 | 1,40 | 400 sq x 700 h |
| 6 | 140 | 1,4 | 140 | 4,6 | 500 x 100 | 270 x 12 x 200 | M14/16 x 300 | 50,5 | 5,87 | 1,26 | 400 sq x 700 h |

Headload Capacity Information

| Height (m) | Mounting Arrangement | Projection (m ²) | Weight (kg) | Extra Light | Light | Medium | Heavy | Extra Heavy |
|------------|----------------------|------------------------------|-------------|-------------|-------|--------|-------|-------------|
| 4 | Post Top | N/A | 50 | 1,45 | 1,27 | 1,17 | 1,07 | 0,86 |
| 5 | Post Top | N/A | 50 | 0,92 | 0,8 | 0,75 | 0,67 | 0,55 |
| 6 | Post Top | N/A | 30 | 0,64 | 0,56 | 0,51 | 0,46 | 0,37 |



Dimensions and technical information given as an indication.

See diagrams beginning on page 308 for info regarding the moments and abbreviations used in above tables.

Valmont reserves the right to make, without delay and without prior notice, the technical or aesthetic modifications that it deems necessary to improve the products of the Standard Collection.

Inari

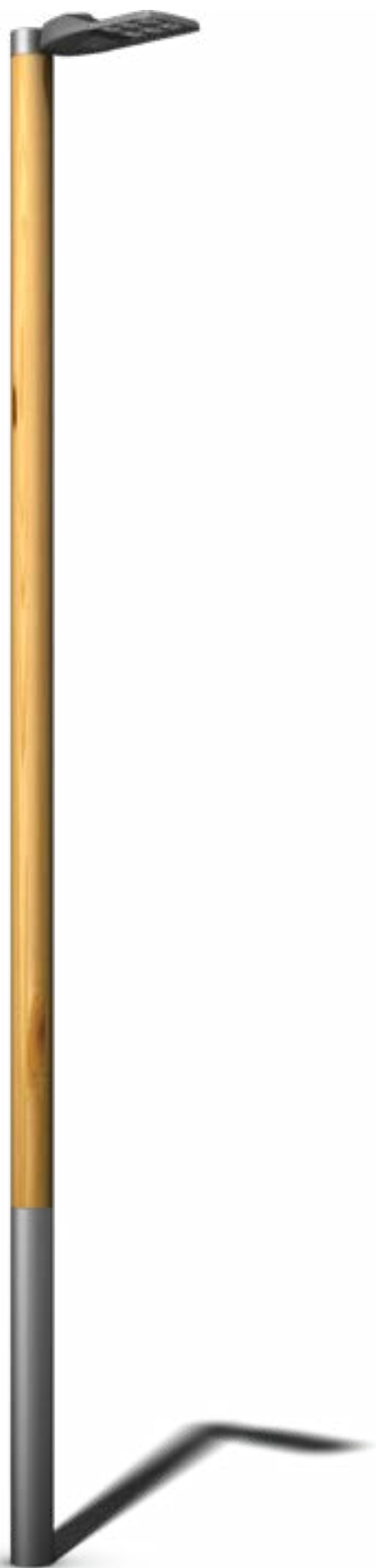

Description

Inari is a range of cylindrical wooden lighting columns which are suitable for city centres, parks and street lighting.

The Inari range of columns offers a robust look with a natural feel. This versatile column is well suited for both contemporary and historic applications and is sure to make a positive impact.

Specifications

All shafts are manufactured from GL28h glued-laminated timber. The raw materials we use are harvested from sustainably managed, PEFC certified forests.

All wood is treated with a water-based stain finish consisting of four protective coats, VOCs <100g/l.

Cylindrical base and flush pole cap, in hot dip galvanised and powder coated S235 steel.

The range is designed and developed according to Eurocode 5, standards ISO EN40 and ISO EN1995.

A ZEP contract for CO₂ compensation is available.

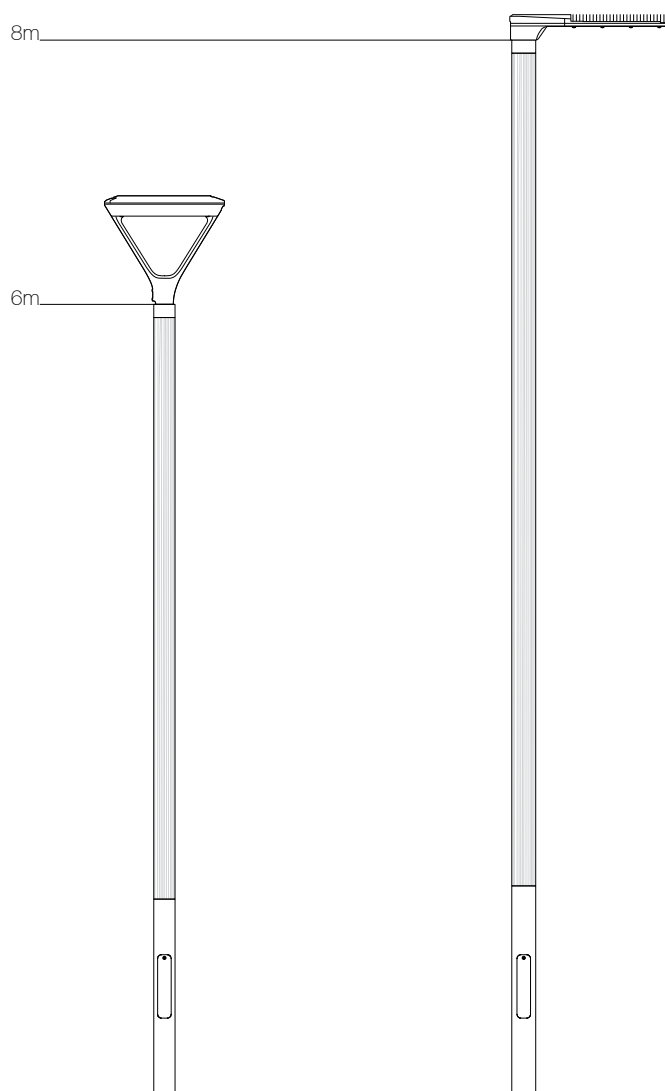



Dimensional Information

Planted Root Option

| Height (m) | BD (mm) | BH (m) | TD (mm) | WH (m) | PD (mm) | DH x DW (mm)h | Mass (kg) | OTM (kNm) | Shear (kN) | Min. Concrete Dia. (mm) |
|------------|---------|--------|---------|--------|---------|---------------|-----------|-----------|------------|-------------------------|
| 6 | 168 | 1,5 | 168 | 4,5 | 1000 | 500 x 100 | 82,5 | 10,51 | 2,02 | 532 |
| 8 | 193 | 1,7 | 193 | 6,3 | 1200 | 600 x 115 | 133 | 16,14 | 2,67 | 468 |

Flange Plated Option

| Height (m) | BD (mm) | BH (m) | TD (mm) | WH (m) | DH x DW (mm) | SL x T x BC (mm) | Anchor Bolts | Mass (kg) | OTM (kNm) | Shear (kN) | Concrete Foundation Size (mm) |
|------------|---------|--------|---------|--------|--------------|------------------|--------------|-----------|-----------|------------|-------------------------------|
| 6 | 168 | 1,5 | 168 | 4,5 | 500 x 100 | 270 x 12 x 200 | M14/16 x 300 | 70,5 | 10,51 | 2,02 | 500 sq x 900 h |
| 8 | 193 | 1,7 | 193 | 6,3 | 600 x 115 | 400 x 15 x 300 | M18/20 x 400 | 126,5 | 16,14 | 2,67 | 600 sq x 1000 h |

Headload Capacity Information

| Height (m) | Mounting Arrangement | Projection (m ²) | Weight (kg) | Extra Light | Light | Medium | Heavy | Extra Heavy |
|------------|----------------------|------------------------------|-------------|-------------|-------|--------|-------|-------------|
| 6 | Post Top | N/A | 30 | 1,58 | 1,39 | 1,28 | 1,18 | 0,92 |
| | Single Arm | 0,5 | 15 | 1,67 | 1,47 | 1,37 | 1,25 | 0,97 |
| | Single Arm | 1,0 | 15 | 1,27 | 1,12 | 1,03 | 0,93 | 0,72 |
| 8 | Post Top | N/A | 30 | 1,20 | 1,03 | 0,93 | 0,83 | 0,62 |
| | Single Arm | 0,5 | 15 | 1,40 | 1,19 | 1,07 | 0,96 | 0,70 |
| | Single Arm | 1,0 | 15 | 1,28 | 1,10 | 0,99 | 0,89 | 0,64 |



Dimensions and technical information given as an indication.

See diagrams beginning on page 308 for info regarding the moments and abbreviations used in above tables.

Valmont reserves the right to make, without delay and without prior notice, the technical or aesthetic modifications that it deems necessary to improve the products of the Standard Collection.



Description

Koli Park is a light duty version of the standard Koli range of square tapered, wooden lighting columns. The Koli Park Range is suitable for city centres and pedestrian areas.

The tapering square profile of the Koli range is unusual for a lighting column. None the less, this simple geometric form pairs well with many types of architecture and can be used to blend in or stand out. The choice is yours!

Specifications

All shafts are manufactured from GL28h glued-laminated timber. The raw materials we use are harvested from sustainably managed, PEFC certified forests.

All wood is treated with a water-based stain finish consisting of four protective coats, VOCs <100g/l.

Square base and flush pole cap, in hot dip galvanised and powder coated S235 steel.

The range is designed and developed according to Eurocode 5, standards ISO EN40 and ISO EN1995.

A ZEP contract for CO₂ compensation is available.

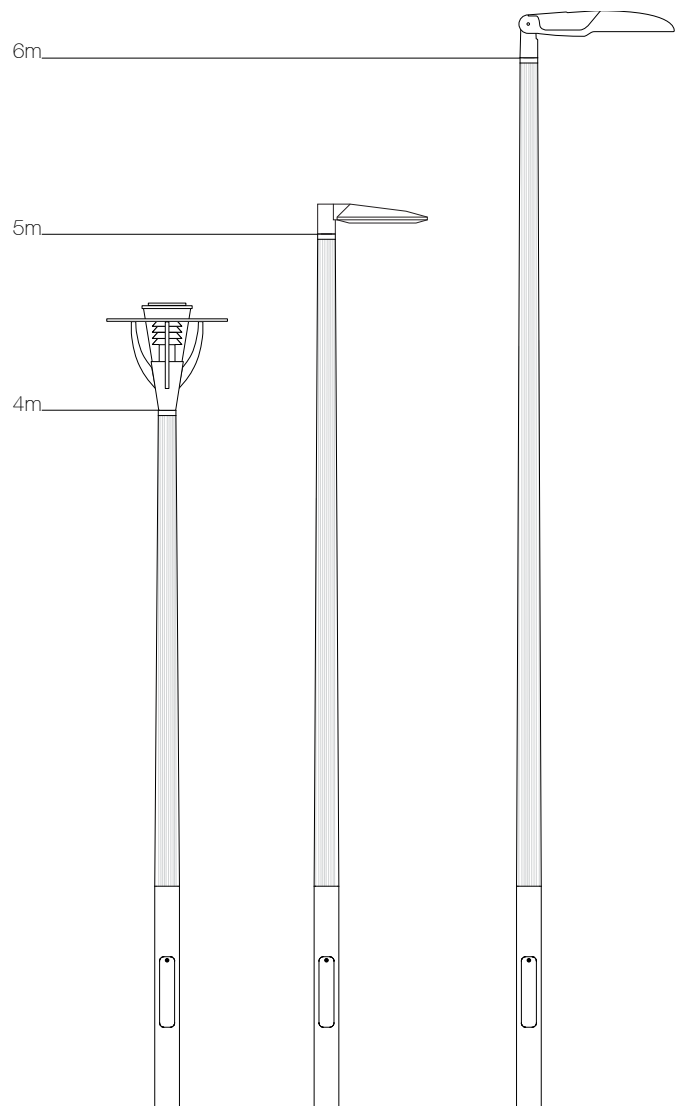



Dimensional Information

Planted Root Option

| Height (m) | BD (mm) | BH (m) | TD (mm) | WH (m) | PD (mm) | DH x DW (mm) | Mass (kg) | OTM (kNm) | Shear (kN) | Min. Concrete Dia. (mm) |
|------------|---------|--------|---------|--------|---------|--------------|-----------|-----------|------------|-------------------------|
| 4 | 140 | 1,4 | 100 | 2,6 | 800 | 500 x 100 | 54,0 | 11,28 | 3,11 | 1138 |
| 5 | 140 | 1,4 | 100 | 3,6 | 800 | 500 x 100 | 58,5 | 11,09 | 3,06 | 1092 |
| 6 | 140 | 1,4 | 100 | 4,6 | 1000 | 500 x 100 | 68,0 | 10,92 | 2,92 | 553 |

Flange Plated Option

| Height (m) | BD (mm) | BH (m) | TD (mm) | WH (m) | DH x DW (mm) | SL x T x BC (mm) | Anchor Bolts | Mass (kg) | OTM (kNm) | Shear (kN) | Concrete Foundation Size (mm) |
|------------|---------|--------|---------|--------|--------------|------------------|--------------|-----------|-----------|------------|-------------------------------|
| 4 | 140 | 1,4 | 100 | 2,6 | 500 x 100 | 270 x 12 x 200 | M14/16 x 300 | 45,0 | 11,28 | 3,11 | 500 sq x 900 h |
| 5 | 140 | 1,4 | 100 | 3,6 | 500 x 100 | 270 x 12 x 200 | M14/16 x 300 | 49,5 | 11,09 | 3,06 | 500 sq x 900 h |
| 6 | 140 | 1,4 | 100 | 4,6 | 500 x 100 | 270 x 12 x 200 | M14/16 x 300 | 55,5 | 10,92 | 2,92 | 500 sq x 900 h |

Headload Capacity Information

| Height (m) | Mounting Arrangement | Projection (m ²) | Weight (kg) | Extra Light | Light | Medium | Heavy | Extra Heavy |
|------------|----------------------|------------------------------|-------------|-------------|-------|--------|-------|-------------|
| 4 | Post Top | N/A | 50 | 2,55 | 2,22 | 2,02 | 1,82 | 1,39 |
| 5 | Post Top | N/A | 50 | 1,64 | 1,4 | 1,26 | 1,13 | 0,84 |
| 6 | Post Top | N/A | 30 | 1,12 | 0,93 | 0,83 | 0,71 | 0,49 |



Dimensions and technical information given as an indication.

See diagrams beginning on page 308 for info regarding the moments and abbreviations used in above tables.

Valmont reserves the right to make, without delay and without prior notice, the technical or aesthetic modifications that it deems necessary to improve the products of the Standard Collection.

Koli



Description

Koli is a range of square tapered, wooden lighting columns which are suitable for city centres, parks and street lighting.

The tapering square profile of the Koli range is unusual for a lighting column. None the less, this simple geometric form pairs well with many types of architecture and can be used to blend in or stand out. The choice is yours!

Specifications

All shafts are manufactured from GL28h glued-laminated timber. The raw materials we use are harvested from sustainably managed, PEFC certified forests.

All wood is treated with a water-based stain finish consisting of four protective coats, VOCs <100g/l.

Square base and flush pole cap, in hot dip galvanised and powder coated S235 steel.

The range is designed and developed according to Eurocode 5, standards ISO EN40 and ISO EN1995.

A ZEP contract for CO₂ compensation is available.

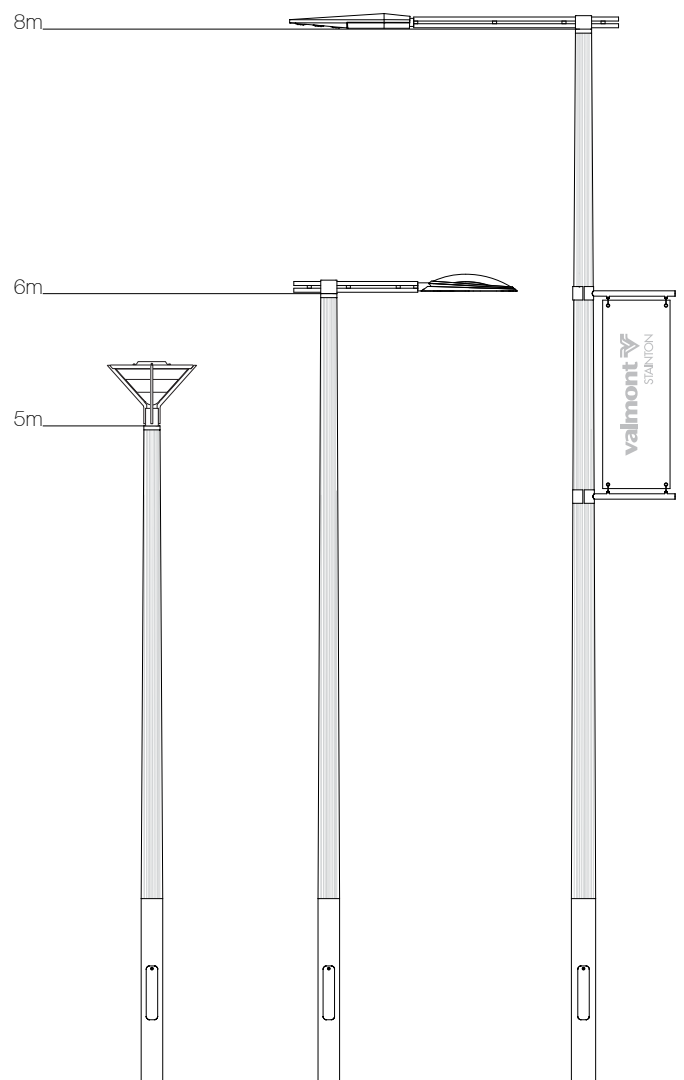



Dimensional Information

Planted Root Option

| Height (m) | BD (mm) | BH (m) | TD (mm) | WH (m) | PD (mm) | DH x DW (mm) | Mass (kg) | OTM (kNm) | Shear (kN) | Min. Concrete Dia. (mm) |
|------------|---------|--------|---------|--------|---------|--------------|-----------|-----------|------------|-------------------------|
| 5 | 160 | 1,5 | 120 | 3,5 | 800 | 500 x 100 | 87,5 | 12,27 | 3,21 | 1208 |
| 6 | 160 | 1,5 | 120 | 4,5 | 1000 | 500 x 100 | 99,0 | 12,25 | 3,26 | 620 |
| 8 | 180 | 1,6 | 120 | 6,4 | 1200 | 600 x 115 | 140 | 22,95 | 4,99 | 665 |

Flange Plated Option

| Height (m) | BD (mm) | BH (m) | TD (mm) | WH (m) | DH x DW (mm) | SL x T x BC (mm) | Anchor Bolts | Mass (kg) | OTM (kNm) | Shear (kN) | Concrete Foundation Size (mm) |
|------------|---------|--------|---------|--------|--------------|------------------|--------------|-----------|-----------|------------|-------------------------------|
| 5 | 160 | 1,5 | 120 | 3,5 | 500 x 100 | 270 x 12 x 200 | M14/16 x 300 | 71,5 | 12,27 | 3,21 | 500 sq x 1000 h |
| 6 | 160 | 1,5 | 120 | 4,5 | 500 x 100 | 270 x 12 x 200 | M14/16 x 300 | 79,0 | 12,25 | 3,26 | 500 sq x 900 h |
| 8 | 180 | 1,6 | 120 | 6,4 | 600 x 115 | 400 x 15 x 300 | M18/20 x 400 | 122 | 22,95 | 4,99 | 700 sq x 1200 h |

Headload Capacity Information

| Height (m) | Mounting Arrangement | Projection (m ²) | Weight (kg) | Extra Light | Light | Medium | Heavy | Extra Heavy |
|------------|----------------------|------------------------------|-------------|-------------|-------|--------|-------|-------------|
| 5 | Post Top | N/A | 50 | 2,03 | 1,73 | 1,54 | 1,37 | 0,98 |
| | Single Arm | 0,5 | 15 | 1,59 | 1,40 | 1,30 | 1,19 | 0,96 |
| | Single Arm | 1,0 | 15 | 0,92 | 0,80 | 0,75 | 0,67 | 0,55 |
| 6 | Post Top | N/A | 30 | 1,48 | 1,21 | 1,06 | 0,91 | 0,58 |
| | Single Arm | 0,5 | 15 | 1,51 | 1,32 | 1,23 | 1,10 | 0,70 |
| | Single Arm | 1,0 | 15 | 0,87 | 0,77 | 0,70 | 0,64 | 0,51 |
| 8 | Post Top | N/A | 30 | 1,14 | 0,92 | 0,79 | 0,66 | 0,39 |
| | Single Arm | 0,5 | 15 | 1,05 | 0,92 | 0,85 | 0,78 | 0,46 |
| | Single Arm | 1,0 | 15 | 0,60 | 0,53 | 0,49 | 0,44 | 0,35 |



Dimensions and technical information given as an indication.

See diagrams beginning on page 308 for info regarding the moments and abbreviations used in above tables.

Valmont reserves the right to make, without delay and without prior notice, the technical or aesthetic modifications that it deems necessary to improve the products of the Standard Collection.



Description

Ruka Park is a light duty version of the standard Ruka range of square wooden lighting columns. Ruka Park is suitable for city centres and pedestrian areas.

The Ruka family has a strong vertical presence, but does not have an overly heavy feel. This minimalistic and familiar form blends into the environment and enhances its surroundings.

Specifications

All shafts are manufactured from GL28h glued-laminated timber. The raw materials we use are harvested from sustainably managed, PEFC certified forests.

All wood is treated with a water-based stain finish consisting of four protective coats, VOCs <100g/l.

Square base and flush pole cap, in hot dip galvanised and powder coated S235 steel.

The range is designed and developed according to Eurocode 5, standards ISO EN40 and ISO EN1995.

A ZEP contract for CO₂ compensation is available.

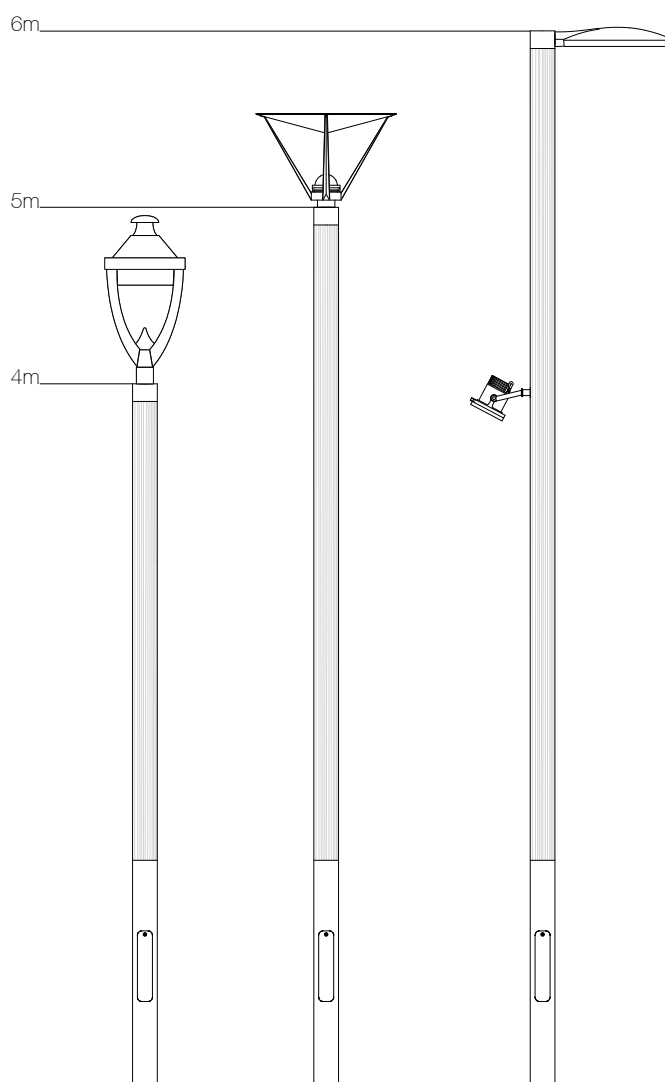



Dimensional Information

Planted Root Option

| Height (m) | BD (mm) | BH (m) | TD (mm) | WH (m) | PD (mm) | DH x DW (mm) | Mass (kg) | OTM (kNm) | Shear (kN) | Min. Concrete Dia. (mm) |
|------------|---------|--------|---------|--------|---------|--------------|-----------|-----------|------------|-------------------------|
| 4 | 140 | 1,4 | 140 | 2,6 | 800 | 500 x 100 | 160 | 11,26 | 3,13 | 1137 |
| 5 | 140 | 1,4 | 140 | 3,6 | 800 | 500 x 100 | 68 | 11,20 | 3,13 | 1103 |
| 6 | 140 | 1,4 | 140 | 4,6 | 1000 | 500 x 100 | 80 | 10,97 | 2,99 | 555 |

Flange Plated Option

| Height (m) | BD (mm) | BH (m) | TD (mm) | WH (m) | DH x DW (mm) | SL x T x BC (mm) | Anchor Bolts | Mass (kg) | OTM (kNm) | Shear (kN) | Concrete Foundation Size (mm) |
|------------|---------|--------|---------|--------|--------------|------------------|--------------|-----------|-----------|------------|-------------------------------|
| 4 | 140 | 1,4 | 140 | 2,6 | 500 x 100 | 270 x 12 x 200 | M14/16 x 300 | 49,5 | 11,26 | 3,13 | 500 sq x 900 h |
| 5 | 140 | 1,4 | 140 | 3,6 | 500 x 100 | 270 x 12 x 200 | M14/16 x 300 | 57,5 | 11,20 | 3,13 | 500 sq x 900 h |
| 6 | 140 | 1,4 | 140 | 4,6 | 500 x 100 | 270 x 12 x 200 | M14/16 x 300 | 65,5 | 10,97 | 2,99 | 500 sq x 900 h |

Headload Capacity Information

| Height (m) | Mounting Arrangement | Projection (m ²) | Weight (kg) | Extra Light | Light | Medium | Heavy | Extra Heavy |
|------------|----------------------|------------------------------|-------------|-------------|-------|--------|-------|-------------|
| 4 | Post Top | N/A | 50 | 2,54 | 2,19 | 1,99 | 1,78 | 1,34 |
| 5 | Post Top | N/A | 50 | 1,59 | 1,35 | 1,21 | 1,07 | 0,78 |
| 6 | Post Top | N/A | 30 | 1,04 | 0,84 | 0,73 | 0,63 | 0,38 |



Dimensions and technical information given as an indication.

See diagrams beginning on page 308 for info regarding the moments and abbreviations used in above tables.

Valmont reserves the right to make, without delay and without prior notice, the technical or aesthetic modifications that it deems necessary to improve the products of the Standard Collection.

Ruka



Description

Ruka is a range of square wooden lighting columns which is suitable for city centres, parks and street lighting.

The Ruka family has a strong vertical presence, but does not have an overly heavy feel. This minimalistic and familiar form blends into the environment and enhances its surroundings.

Specifications

All shafts are manufactured from GL28h glued-laminated timber. The raw materials we use are harvested from sustainably managed, PEFC certified forests.

All wood is treated with a water-based stain finish consisting of four protective coats, VOCs <100g/l.

Square base and flush pole cap, in hot dip galvanised and powder coated S235 steel.

The range is designed and developed according to Eurocode 5, standards ISO EN40 and ISO EN1995.

A ZEP contract for CO₂ compensation is available.

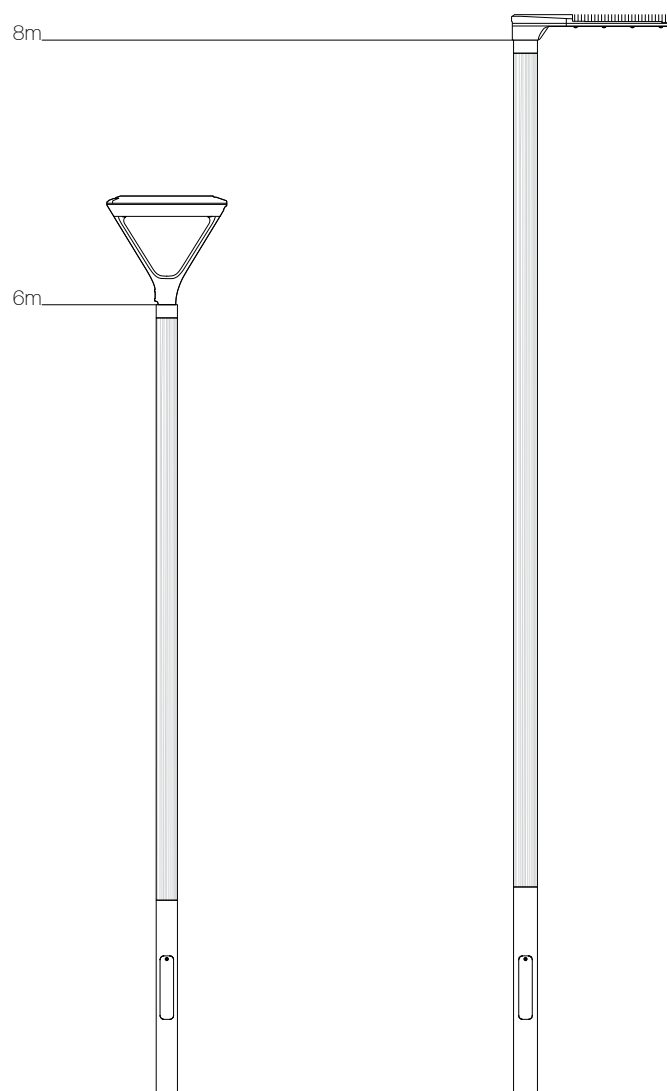



Dimensional Information

Planted Root Option

| Height (m) | BD (mm) | BH (m) | TD (mm) | WH (m) | PD (mm) | DH x DW (mm) | Mass (kg) | OTM (kNm) | Shear (kN) | Min. Concrete Dia. (mm) |
|------------|---------|--------|---------|--------|---------|--------------|-----------|-----------|------------|-------------------------|
| 6 | 160 | 1,5 | 160 | 4,5 | 1000 | 500 x 100 | 110 | 12,27 | 3,05 | 621 |
| 8 | 180 | 1,6 | 180 | 6,4 | 1200 | 600 x 115 | 167 | 23,25 | 5,20 | 674 |

Flange Plated Option

| Height (m) | BD (mm) | BH (m) | TD (mm) | WH (m) | DH x DW (mm) | SL x T x BC (mm) | Anchor Bolts | Mass (kg) | OTM (kNm) | Shear (kN) | Concrete Foundation Size (mm) |
|------------|---------|--------|---------|--------|--------------|------------------|--------------|-----------|-----------|------------|-------------------------------|
| 6 | 160 | 1,5 | 160 | 4,5 | 500 x 100 | 270 x 12 x 200 | M14/16 x 300 | 90 | 12,27 | 3,05 | 500 sq x 1000 h |
| 8 | 180 | 1,6 | 180 | 6,4 | 600 x 115 | 400 x 15 x 300 | M18/20 x 400 | 149 | 23,25 | 5,20 | 700 sq x 1200 h |

Headload Capacity Information

| Height (m) | Mounting Arrangement | Projection (m ²) | Weight (kg) | Extra Light | Light | Medium | Heavy | Extra Heavy |
|------------|----------------------|------------------------------|-------------|-------------|-------|--------|-------|-------------|
| 6 | Post Top | N/A | 30 | 1,38 | 1,11 | 0,94 | 0,8 | 0,46 |
| | Single Arm | 0,5 | 15 | 1,66 | 1,33 | 1,14 | 0,96 | 0,56 |
| | Single Arm | 1,0 | 15 | 1,53 | 1,21 | 1,03 | 0,85 | 0,46 |
| 8 | Post Top | N/A | 30 | 0,93 | 0,71 | 0,58 | 0,45 | 0,17 |
| | Single Arm | 0,5 | 15 | 1,12 | 0,85 | 0,69 | 0,53 | 0,21 |
| | Single Arm | 1,0 | 15 | 1,04 | 0,77 | 0,62 | 0,46 | 0,14 |



Dimensions and technical information given as an indication.

See diagrams beginning on page 308 for info regarding the moments and abbreviations used in above tables.

Valmont reserves the right to make, without delay and without prior notice, the technical or aesthetic modifications that it deems necessary to improve the products of the Standard Collection.

Ontelo Round

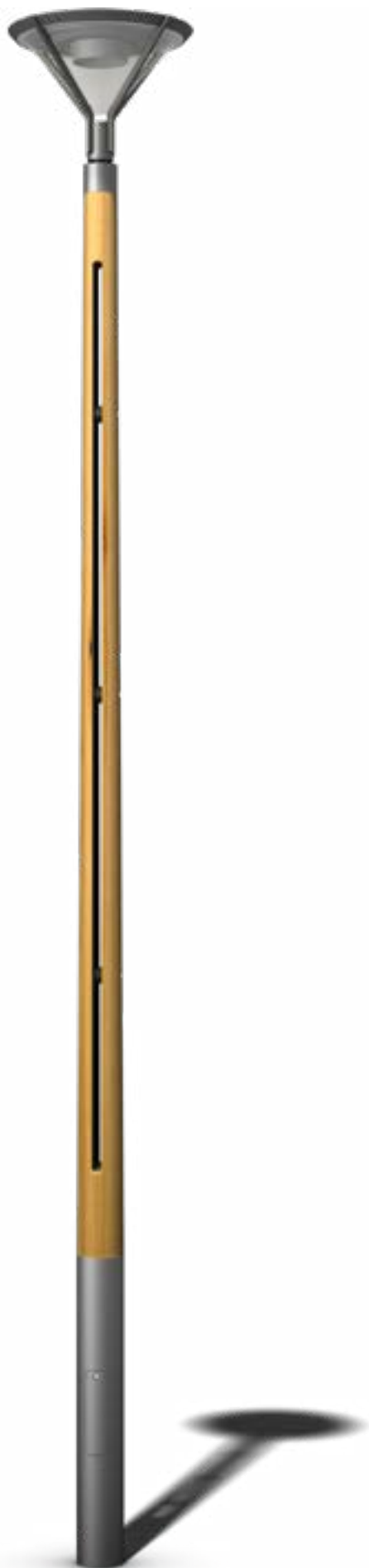

Description

The Ontelo range of columns cleverly plays with negative space to create an eye catching lighting column.

The simple round base soon gives way to a sculpted conical shaft with a hollowed mid-section. The hollow section reduces the visual weight of the column and creates an ever changing canvas of shadows and highlights.

Specifications

All shafts are manufactured from GL28h glued-laminated timber. The raw materials we use are harvested from sustainably managed, PEFC certified forests.

All wood is treated with a water-based stain finish consisting of four protective coats, VOCs <100g/l.

Cylindrical base and flush pole cap, in hot dip galvanised and powder coated S235 steel.

The range is designed and developed according to Eurocode 5, standards ISO EN40 and ISO EN1995.

A ZEP contract for CO₂ compensation is available.

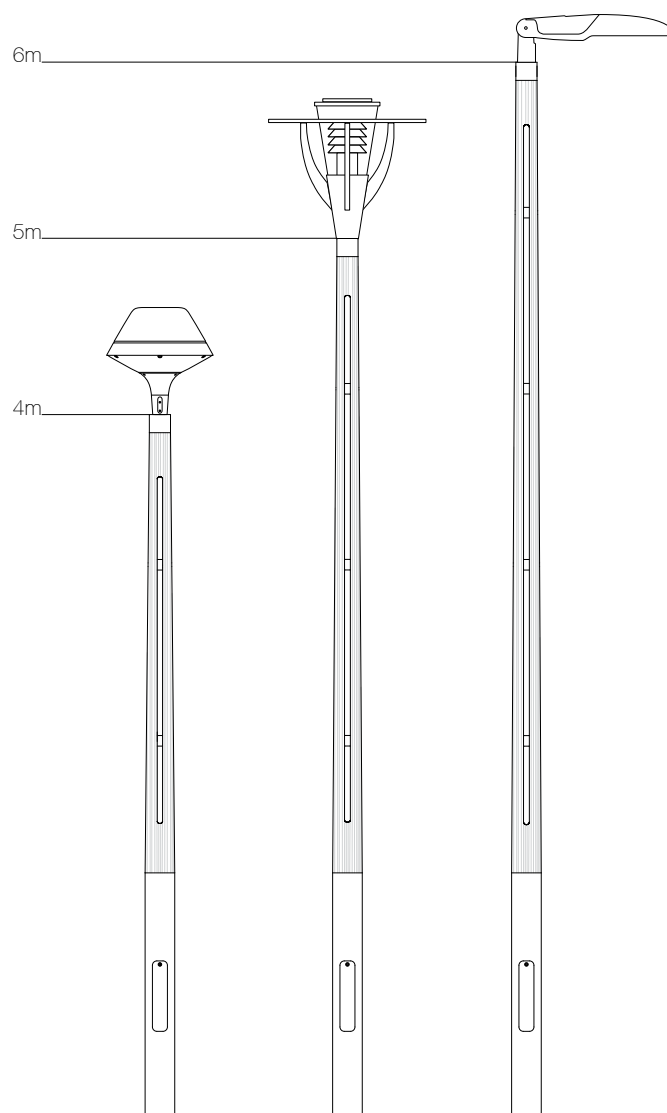



Dimensional Information

Planted Root Option

| Height (m) | BD (mm) | BH (m) | TD (mm) | WH (m) | PD (mm) | DH x DW (mm) | Mass (kg) | OTM (kNm) | Shear (kN) | Min. Concrete Dia. (mm) |
|------------|---------|--------|---------|--------|----------|--------------|-----------|-----------|------------|-------------------------|
| 4 | 168 | 1,4 | 120 | 2,6 | 400 x 85 | 800 | 52 | 2,67 | 0,80 | 270 |
| 5 | 168 | 1,4 | 120 | 3,6 | 400 x 85 | 800 | 58 | 3,74 | 1,00 | 368 |
| 6 | 168 | 1,4 | 120 | 4,6 | 400 x 85 | 1000 | 66,5 | 4,16 | 1,01 | 210 |

Flange Plated Option

| Height (m) | BD (mm) | BH (m) | TD (mm) | WH (m) | DH x DW (mm) | SL x T x BC (mm) | Anchor Bolts | Mass (kg) | OTM (kNm) | Shear (kN) | Concrete Foundation Size (mm) |
|------------|---------|--------|---------|--------|--------------|------------------|--------------|-----------|-----------|------------|-------------------------------|
| 4 | 168 | 1,4 | 120 | 2,6 | 400 x 85 | 270 x 12 x 200 | M14/16 x 300 | 43,5 | 2,67 | 0,80 | 400 sq x 500 h |
| 5 | 168 | 1,4 | 120 | 3,6 | 400 x 85 | 270 x 12 x 200 | M14/16 x 300 | 49,5 | 3,74 | 1,00 | 400 sq x 600 h |
| 6 | 168 | 1,4 | 120 | 4,6 | 400 x 85 | 270 x 12 x 200 | M14/16 x 300 | 54,5 | 4,16 | 1,01 | 400 sq x 600 h |

Headload Capacity Information

| Height (m) | Mounting Arrangement | Projection (m ²) | Weight (kg) | Extra Light | Light | Medium | Heavy | Extra Heavy |
|------------|----------------------|------------------------------|-------------|-------------|-------|--------|-------|-------------|
| 4 | Post Top | N/A | 50 | 0,5 | 0,43 | 0,39 | 0,36 | 0,28 |
| 5 | Post Top | N/A | 50 | 0,48 | 0,42 | 0,38 | 0,35 | 0,28 |
| 6 | Post Top | N/A | 30 | 0,37 | 0,32 | 0,3 | 0,26 | 0,21 |



Dimensions and technical information given as an indication.

See diagrams beginning on page 308 for info regarding the moments and abbreviations used in above tables.

Valmont reserves the right to make, without delay and without prior notice, the technical or aesthetic modifications that it deems necessary to improve the products of the Standard Collection.

Ontelo_{Square}



Description

The Ontelo range of columns cleverly plays with negative space to create an eye catching lighting column.

The simple square base soon gives way to a sculpted parallel shaft with a hollowed mid-section. The hollow section reduces the visual weight of the column and creates an ever changing canvas of shadows and highlights.

Specifications

All shafts are manufactured from GL28h glued-laminated timber. The raw materials we use are harvested from sustainably managed, PEFC certified forests.

All wood is treated with a water-based stain finish consisting of four protective coats, VOCs <100g/l.

Square base and flush pole cap, in hot dip galvanised and powder coated S235 steel.

The range is designed and developed according to Eurocode 5, standards ISO EN40 and ISO EN1995.

A ZEP contract for CO₂ compensation is available.

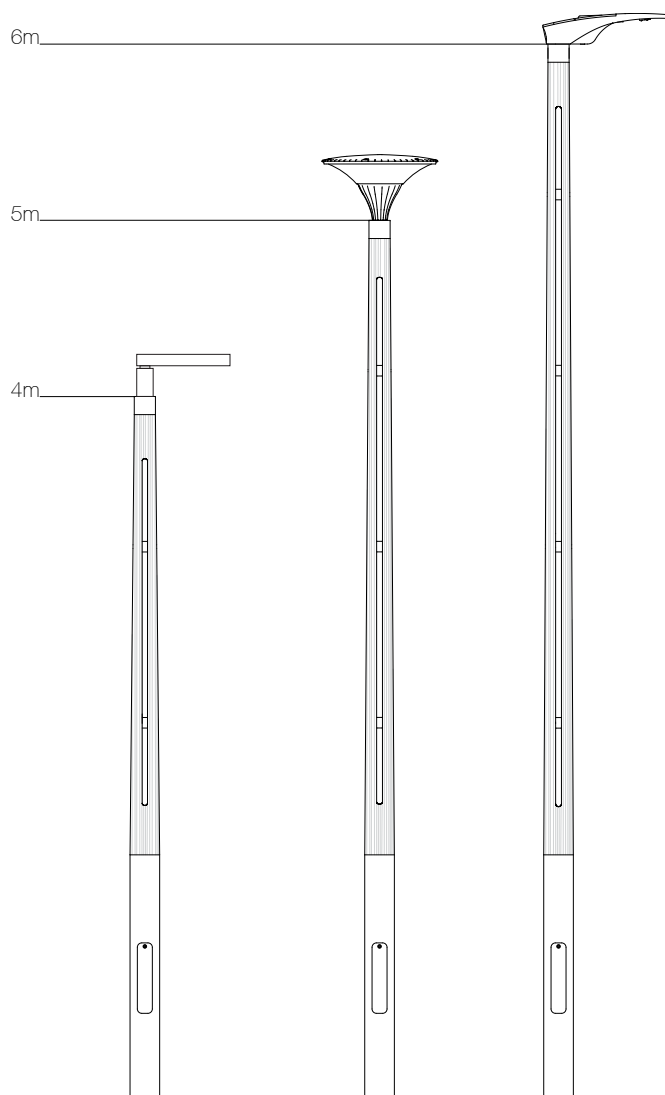



Dimensional Information

Planted Root Option

| Height (m) | BD (mm) | BH (m) | TD (mm) | WH (m) | PD (mm) | DH x DW (mm) | Mass (kg) | OTM (kNm) | Shear (kN) | Min. Concrete Dia. (mm) |
|------------|---------|--------|---------|--------|----------|--------------|-----------|-----------|------------|-------------------------|
| 4 | 160 | 1,4 | 120 | 2,6 | 400 x 85 | 800 | 64 | 4,51 | 1,69 | 455 |
| 5 | 160 | 1,4 | 120 | 3,6 | 400 x 85 | 800 | 71 | 5,53 | 1,96 | 544 |
| 6 | 160 | 1,4 | 120 | 4,6 | 400 x 85 | 1000 | 82 | 6,61 | 2,15 | 335 |

Flange Plated Option

| Height (m) | BD (mm) | BH (m) | TD (mm) | WH (m) | DH x DW (mm) | SL x T x BC (mm) | Anchor Bolts | Mass (kg) | OTM (kNm) | Shear (kN) | Concrete Foundation Size (mm) |
|------------|---------|--------|---------|--------|--------------|------------------|--------------|-----------|-----------|------------|-------------------------------|
| 4 | 160 | 1,4 | 120 | 2,6 | 400 x 85 | 270 x 12 x 200 | M14/16 x 300 | 53 | 4,51 | 1,69 | 400 sq x 600 h |
| 5 | 160 | 1,4 | 120 | 3,6 | 400 x 85 | 270 x 12 x 200 | M14/16 x 300 | 60 | 5,53 | 1,96 | 400 sq x 700 h |
| 6 | 160 | 1,4 | 120 | 4,6 | 400 x 85 | 270 x 12 x 200 | M14/16 x 300 | 67 | 6,61 | 2,15 | 400 sq x 800 h |

Headload Capacity Information

| Height (m) | Mounting Arrangement | Projection (m ²) | Weight (kg) | Extra Light | Light | Medium | Heavy | Extra Heavy |
|------------|----------------------|------------------------------|-------------|-------------|-------|--------|-------|-------------|
| 4 | Post Top | N/A | 50 | 0,64 | 0,56 | 0,5 | 0,42 | 0,21 |
| 5 | Post Top | N/A | 50 | 0,38 | 0,32 | 0,29 | 0,24 | 0,04 |
| 6 | Post Top | N/A | 30 | 0,28 | 0,23 | 0,18 | 0,11 | 0,00 |



Dimensions and technical information given as an indication.

See diagrams beginning on page 308 for info regarding the moments and abbreviations used in above tables.

Valmont reserves the right to make, without delay and without prior notice, the technical or aesthetic modifications that it deems necessary to improve the products of the Standard Collection.

Laine



Description

The Laine range derives its name from the Finnish word for wave. One look at the tapering wooden shaft and it's easy to see why this name was chosen.

The Column consists of a square steel base section and a tapering wooden shaft with rhythmic carvings. The carvings add visual interest while playing with light and shadow.

Specifications

All shafts are manufactured from GL28h glued-laminated timber. The raw materials we use are harvested from sustainably managed, PEFC certified forests.

All wood is treated with a water-based stain finish consisting of four protective coats, VOCs <100g/l.

Square base and flush pole cap, in hot dip galvanised and powder coated S235 steel.

The range is designed and developed according to Eurocode 5, standards ISO EN40 and ISO EN1995.

A ZEP contract for CO₂ compensation is available.

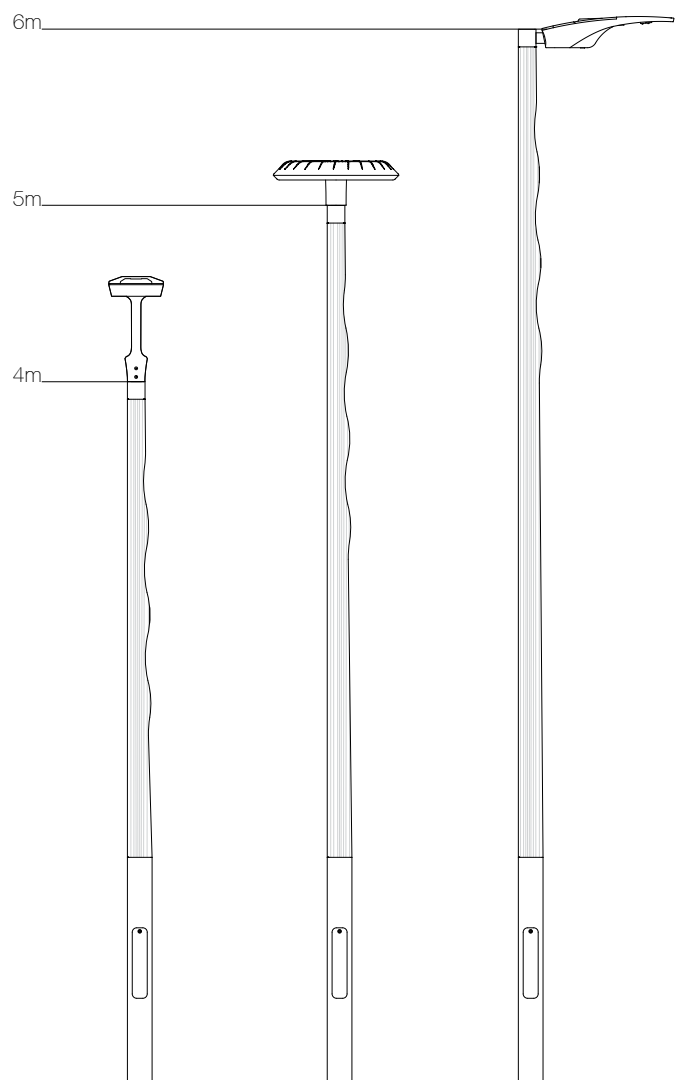



Dimensional Information

Planted Root Option

| Height (m) | BD (mm) | BH (m) | TD (mm) | WH (m) | PD (mm) | DH x DW (mm) | Mass (kg) | OTM (kNm) | Shear (kN) | Min. Concrete Dia. (mm) |
|------------|---------|--------|---------|--------|----------|--------------|-----------|-----------|------------|-------------------------|
| 4 | 140 | 1,3 | 100 | 2,7 | 400 x 85 | 800 | 52,5 | 5,60 | 2,05 | 566 |
| 5 | 140 | 1,3 | 100 | 3,7 | 400 x 85 | 800 | 57,5 | 8,04 | 2,48 | 792 |
| 6 | 140 | 1,3 | 100 | 4,7 | 400 x 85 | 1000 | 67 | 10,58 | 2,87 | 535 |

Flange Plated Option

| Height (m) | BD (mm) | BH (m) | TD (mm) | WH (m) | DH x DW (mm) | SL x T x BC (mm) | Anchor Bolts | Mass (kg) | OTM (kNm) | Shear (kN) | Concrete Foundation Size (mm) |
|------------|---------|--------|---------|--------|--------------|------------------|--------------|-----------|-----------|------------|-------------------------------|
| 4 | 140 | 1,3 | 140 | 2,7 | 400 x 85 | 270 x 12 x 200 | M14/16 x 300 | 43,5 | 5,60 | 2,05 | 400 sq x 700 h |
| 5 | 140 | 1,3 | 140 | 3,7 | 400 x 85 | 270 x 12 x 200 | M14/16 x 300 | 48,5 | 8,04 | 2,48 | 400 sq x 800 h |
| 6 | 140 | 1,3 | 140 | 4,7 | 400 x 85 | 270 x 12 x 200 | M14/16 x 300 | 54,5 | 10,58 | 2,87 | 500 sq x 900 h |

Headload Capacity Information

| Height (m) | Mounting Arrangement | Projection (m ²) | Weight (kg) | Extra Light | Light | Medium | Heavy | Extra Heavy |
|------------|----------------------|------------------------------|-------------|-------------|-------|--------|-------|-------------|
| 4 | Post Top | N/A | 30 | 0,50 | 0,50 | 0,50 | 0,50 | 0,50 |
| 5 | Post Top | N/A | 30 | 0,50 | 0,50 | 0,50 | 0,50 | 0,50 |
| 6 | Post Top | N/A | 30 | 0,50 | 0,50 | 0,50 | 0,50 | 0,45 |



Dimensions and technical information given as an indication.

See diagrams beginning on page 308 for info regarding the moments and abbreviations used in above tables.

Valmont reserves the right to make, without delay and without prior notice, the technical or aesthetic modifications that it deems necessary to improve the products of the Standard Collection.



Description

The Seka Park range of products is a light duty version of the standard Seka range. The goal of the design is to play with the ratio between wood and steel to create a slightly different take on the standard wooden lighting column.

The Extended steel section at the top of the column allows for post top and laterally mounted lanterns.

Specifications

All shafts are manufactured from GL28h glued-laminated timber. The raw materials we use are harvested from sustainably managed, PEFC certified forests.

All wood is treated with a water-based stain finish consisting of four protective coats, VOCs <100g/l.

Cylindrical base and flush pole cap, in hot dip galvanised and powder coated S235 steel.

The range is designed and developed according to Eurocode 5, standards ISO EN40 and ISO EN1995.

A ZEP contract for CO₂ compensation is available.

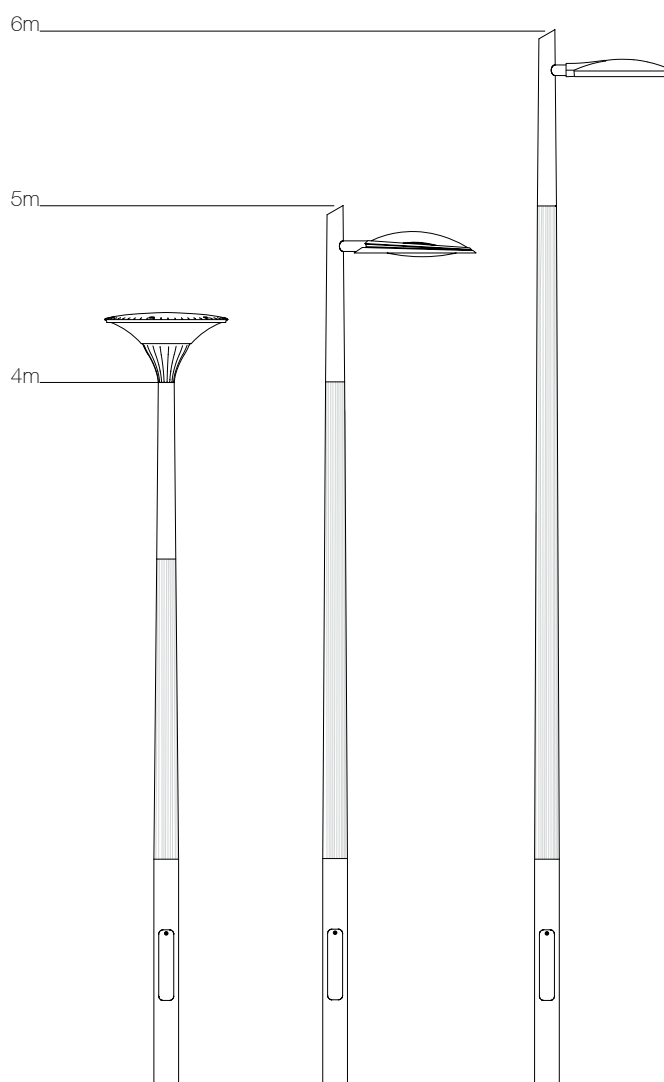



Dimensional Information

Planted Root Option

| Height (m) | BD (mm) | BH (m) | TD (mm) | WH (m) | TL (m) | PD (mm) | DH x DW (mm) | Mass (kg) | OTM (kNm) | Shear (kN) | Min. Concrete Dia. (mm) |
|------------|---------|--------|---------|--------|--------|---------|--------------|-----------|-----------|------------|-------------------------|
| 4 | 140 | 1,3 | 90 | 1,7 | 1,0 | 800 | 400 x 85 | 42 | 5,31 | 1,43 | 536 |
| 5 | 140 | 1,3 | 90 | 2,7 | 1,0 | 800 | 400 x 85 | 47 | 5,93 | 1,40 | 584 |
| 6 | 140 | 1,3 | 90 | 3,7 | 1,0 | 1000 | 400 x 85 | 53 | 5,83 | 1,29 | 295 |

Flange Plated Option

| Height (m) | BD (mm) | BH (m) | TD (mm) | WH (m) | TL (m) | DH x DW (mm) | SL x T x BC (mm) | Anchor Bolts | Mass (kg) | OTM (kNm) | Shear (kN) | Concrete Foundation Size (mm) |
|------------|---------|--------|---------|--------|--------|--------------|------------------|--------------|-----------|-----------|------------|-------------------------------|
| 4 | 140 | 1,3 | 90 | 1,7 | 1,0 | 400 x 85 | 270 x 12 x 200 | M14/16 x 300 | 36,5 | 5,31 | 1,43 | 400 sq x 700 h |
| 5 | 140 | 1,3 | 90 | 2,7 | 1,0 | 400 x 85 | 270 x 12 x 200 | M14/16 x 300 | 41,5 | 5,93 | 1,40 | 400 sq x 700 h |
| 6 | 140 | 1,3 | 90 | 3,7 | 1,0 | 400 x 85 | 270 x 12 x 200 | M14/16 x 300 | 45,5 | 5,83 | 1,29 | 400 sq x 700 h |

Headload Capacity Information

| Height (m) | Mounting Arrangement | Projection (m ²) | Weight (kg) | Extra Light | Light | Medium | Heavy | Extra Heavy |
|------------|----------------------|------------------------------|-------------|-------------|-------|--------|-------|-------------|
| 4 | Post Top | N/A | 50 | 1,10 | 0,97 | 0,89 | 0,82 | 0,65 |
| 5 | Post Top | N/A | 50 | 0,86 | 0,75 | 0,69 | 0,62 | 0,49 |
| 6 | Post Top | N/A | 30 | 0,60 | 0,51 | 0,46 | 0,42 | 0,32 |



Dimensions and technical information given as an indication.

See diagrams beginning on page 308 for info regarding the moments and abbreviations used in above tables.

Valmont reserves the right to make, without delay and without prior notice, the technical or aesthetic modifications that it deems necessary to improve the products of the Standard Collection.

Seka



Description

Seka is a range of conical wooden lighting columns which is suitable for city centres, parks and street lighting. The goal of the design is to play with the ratio between wood and steel to create a slightly different take on the standard wooden lighting column.

The Extended steel section at the top of the column allows for post top, lateral, and bracket mounted lanterns.

Specifications

All shafts are manufactured from GL28h glued-laminated timber. The raw materials we use are harvested from sustainably managed, PEFC certified forests.

All wood is treated with a water-based stain finish consisting of four protective coats, VOCs <100g/l.

Cylindrical base and flush pole cap, in hot dip galvanised and powder coated S235 steel.

The range is designed and developed according to Eurocode 5, standards ISO EN40 and ISO EN1995.

A ZEP contract for CO₂ compensation is available.

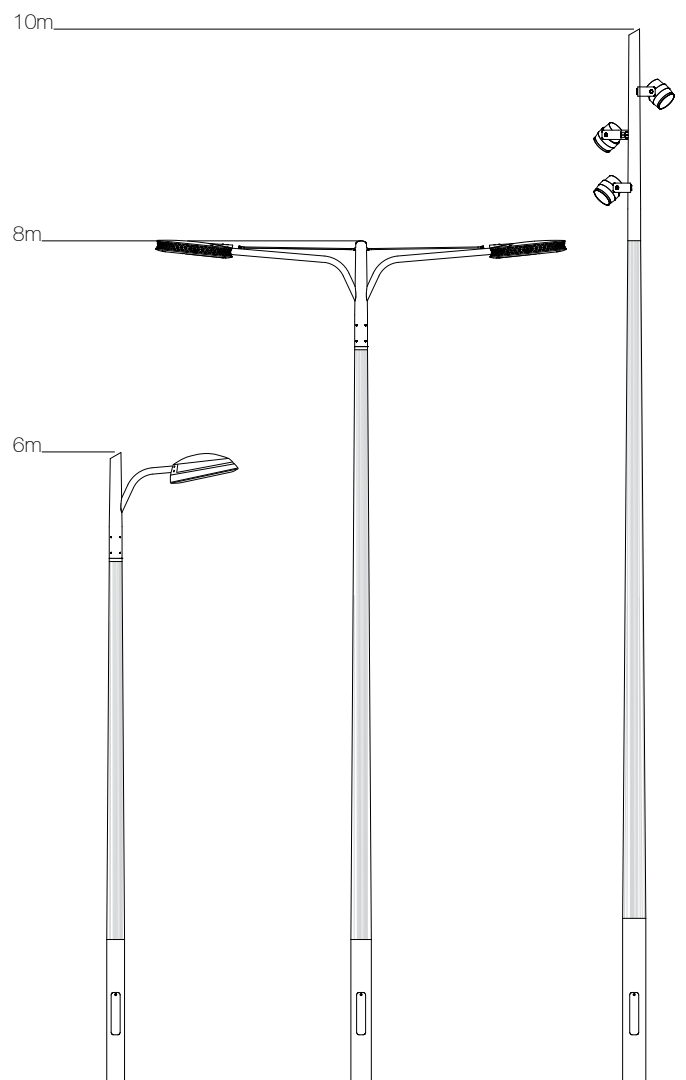



Dimensional Information

Planted Root Option

| Height (m) | BD (mm) | BH (m) | TD (mm) | WH (m) | TL (m) | PD (mm) | DH x DW (mm) | Mass (kg) | OTM (kNm) | Shear (kN) | Min. Concrete Dia. (mm) |
|------------|---------|--------|---------|--------|--------|---------|--------------|-----------|-----------|------------|-------------------------|
| 6 | 168 | 1,4 | 100 | 3,6 | 1 | 1000 | 400 x 85 | 73 | 10,26 | 1,94 | 519 |
| | 168 | 1,4 | 100 | 2,6 | 2 | 1000 | 400 x 85 | 75 | 7,46 | 1,52 | 377 |
| 7 | 193 | 1,4 | 100 | 4,6 | 1 | 1200 | 400 x 85 | 98 | 14,10 | 2,34 | 414 |
| | 193 | 1,4 | 100 | 3,6 | 2 | 1200 | 400 x 85 | 98 | 9,15 | 1,69 | 269 |
| 8 | 193 | 1,4 | 100 | 5,6 | 1 | 1200 | 400 x 85 | 106 | 15,17 | 2,38 | 440 |
| | 193 | 1,4 | 100 | 4,6 | 2 | 1200 | 400 x 85 | 106 | 11,15 | 1,91 | 323 |
| 10 | 219 | 1,6 | 100 | 7,4 | 1 | 1500 | 500 x 100 | 159 | 21,99 | 2,96 | 326 |
| | 219 | 1,6 | 100 | 6,4 | 2 | 1500 | 500 x 100 | 158 | 15,80 | 2,38 | 235 |

Flange Plated Option

| Height (m) | TD (mm) | BD (mm) | BH (m) | WH (m) | TL (m) | DH x DW (mm) | SL x T x BC (mm) | Anchor Bolts | Mass (kg) | OTM (kNm) | Shear (kN) | Concrete Foundation Size (mm) |
|------------|---------|---------|--------|--------|--------|--------------|------------------|--------------|-----------|-----------|------------|-------------------------------|
| 6 | 100 | 168 | 1,4 | 3,6 | 1 | 400 x 85 | 270 x 12 x 200 | M14/16 x 300 | 61,0 | 10,26 | 1,94 | 500 sq x 800 h |
| | 100 | 168 | 1,4 | 2,6 | 2 | 400 x 85 | 270 x 12 x 200 | M14/16 x 300 | 63,5 | 7,46 | 1,52 | 400 sq x 800 h |
| 7 | 100 | 193 | 1,4 | 4,6 | 1 | 400 x 85 | 400 x 15 x 300 | M18/20 x 400 | 88,5 | 14,10 | 2,34 | 500 sq x 1000 h |
| | 100 | 193 | 1,4 | 3,6 | 2 | 400 x 85 | 400 x 15 x 300 | M18/20 x 400 | 89,0 | 9,15 | 1,69 | 500 sq x 800 h |
| 8 | 100 | 193 | 1,4 | 5,6 | 1 | 400 x 85 | 400 x 15 x 300 | M18/20 x 400 | 96,5 | 15,17 | 2,38 | 500 sq x 1000 h |
| | 100 | 193 | 1,4 | 4,6 | 2 | 400 x 85 | 400 x 15 x 300 | M18/20 x 400 | 97,0 | 11,15 | 1,91 | 500 sq x 900 h |
| 10 | 100 | 219 | 1,6 | 7,4 | 1 | 500 x 100 | 400 x 15 x 300 | M18/20 x 400 | 138,0 | 21,99 | 2,96 | 600 sq x 1200 h |
| | 100 | 219 | 1,6 | 6,4 | 2 | 500 x 100 | 400 x 15 x 300 | M18/20 x 400 | 136,5 | 15,80 | 2,38 | 600 sq x 1000 h |

Headload Capacity Information

| Height (m) | TL (m) | Mounting Arrangement | Projection (m ²) | Weight (kg) | Extra Light | Light | Medium | Heavy | Extra Heavy |
|------------|--------|----------------------|------------------------------|-------------|-------------|-------|--------|-------|-------------|
| 6 | 1 | Post Top | N/A | 30 | 1,47 | 1,28 | 1,18 | 1,07 | 0,86 |
| | 1 | Single Arm | 0,5 | 15 | 1,12 | 0,99 | 0,91 | 0,84 | 0,67 |
| | 2 | Post Top | N/A | 30 | 0,94 | 0,83 | 0,76 | 0,69 | 0,55 |
| 7 | 1 | Post Top | N/A | 30 | 1,72 | 1,51 | 1,39 | 1,27 | 1,03 |
| | 1 | Single Arm | 0,5 | 15 | 1,12 | 0,99 | 0,91 | 0,84 | 0,67 |
| | 2 | Post Top | N/A | 30 | 0,93 | 0,82 | 0,75 | 0,69 | 0,55 |
| 8 | 1 | Post Top | N/A | 30 | 1,07 | 0,93 | 0,85 | 0,78 | 0,62 |
| | 1 | Single Arm | 0,5 | 15 | 0,79 | 0,7 | 0,64 | 0,59 | 0,48 |
| | 2 | Post Top | N/A | 30 | 0,63 | 0,56 | 0,51 | 0,46 | 0,37 |
| 10 | 1 | Post Top | N/A | 40 | 1,06 | 0,93 | 0,85 | 0,77 | 0,59 |
| | 1 | Single Arm | 0,5 | 15 | 0,73 | 0,65 | 0,59 | 0,55 | 0,43 |
| | 2 | Post Top | N/A | 40 | 0,56 | 0,49 | 0,44 | 0,41 | 0,32 |



Dimensions and technical information given as an indication.

See diagrams beginning on page 308 for info regarding the moments and abbreviations used in above tables.

Valmont reserves the right to make, without delay and without prior notice, the technical or aesthetic modifications that it deems necessary to improve the products of the Standard Collection.

Kartio



Description

The Kartio range takes wooden lighting columns to new heights.

Thanks to careful material selection and engineering, Valmont is able to offer wooden lighting columns in heights from 12 and up to 20 metres.

Specifications

All shafts are manufactured from GL28h glued-laminated timber. The raw materials we use are harvested from sustainably managed, PEFC certified forests.

All wood is treated with a water-based stain finish consisting of four protective coats, VOCs <100g/l.

Cylindrical base and flush pole cap, in hot dip galvanised and powder coated S235 steel.

The range is designed and developed according to Eurocode 5, standards ISO EN40 and ISO EN1995.

A ZEP contract for CO₂ compensation is available.

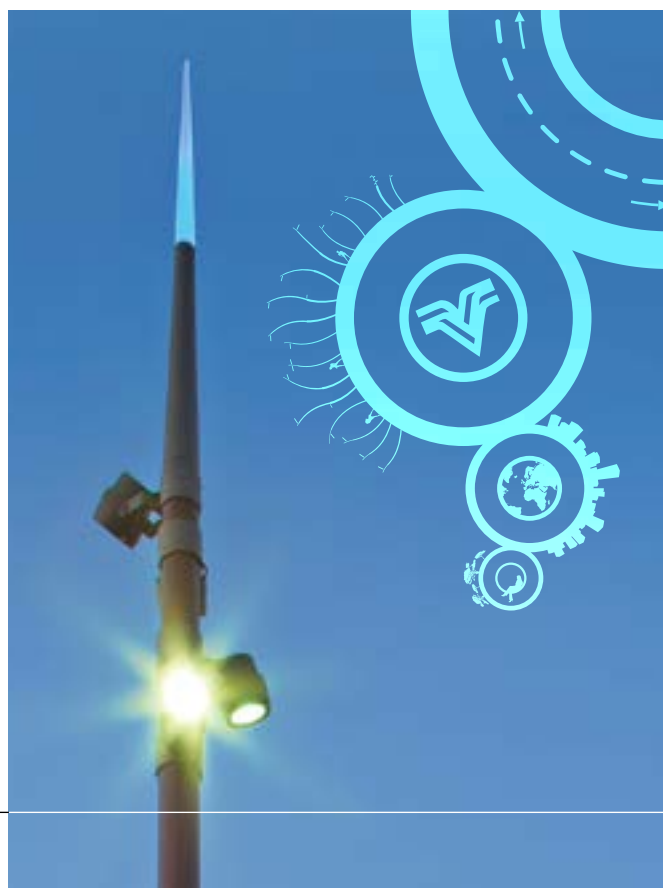



Bespoke Columns

Let Your Imagination Run Wild...

Wood is a creative material that gives designers the freedom to create shapes that might be impossible or cost prohibitive with other materials.

Valmont uses a combination of state of the art CNC milling machines and talented craftsmen to transform raw material into beautiful, bespoke lighting columns.



Designed to Stand Out...

An important part of urban design is focusing on the local identity of cities, urban areas and the people who create the culture within.

Lighting columns can be used to reflect the surrounding culture and local identity by employing a personalized approach. This means the creative use of different elements such as graphics, engravings, and even integrated lighting can be used to transform a once "standard" design in to a bespoke focal point.





A Springboard To Creativity...

Wood is an unique and sought after material in the lighting industry. It offers a warm, natural feel, strength, flexibility, and a high level of environmental responsibility.

Including wooden lighting columns in your next project can elevate your installation from ordinary to extraordinary. Valmont has a talented team of designers, engineers, and craftsmen standing by to help you explore and unlock the potential of this natural material. What are you waiting for?



For additional information and our full product offering please see the our dedicated Wooden Columns Brochure.

Stainless Steel Columns



Project Lead: Balfour Beatty | Installation: St Johns Crossing



Severn



Description

A 12 sided, multifold, Stainless Steel tapering lighting column. Stainless steel lighting columns deliver excellent value by providing a superb aesthetic appeal, low maintenance, and long life.

Specifications

Columns are available in heights of 4,7 and 5,7 metres and can be used for post top applications or supplied with demountable bracket arm arrangements.

Stainless Steel is high strength, lightweight, and 100% recyclable. Stainless Steel lighting columns have been in service for over 30 years with an unequalled track record with regards to corrosion, and offer excellent value when assessing whole life cost. Full material specification can be found on page 26.

Valmont Stainton operates a Quality Assurance system which complies with requirements of BS EN ISO 9001.

Our welders and welding procedures are independently certified in accordance with EN ISO 9606 and EN ISO 15607.

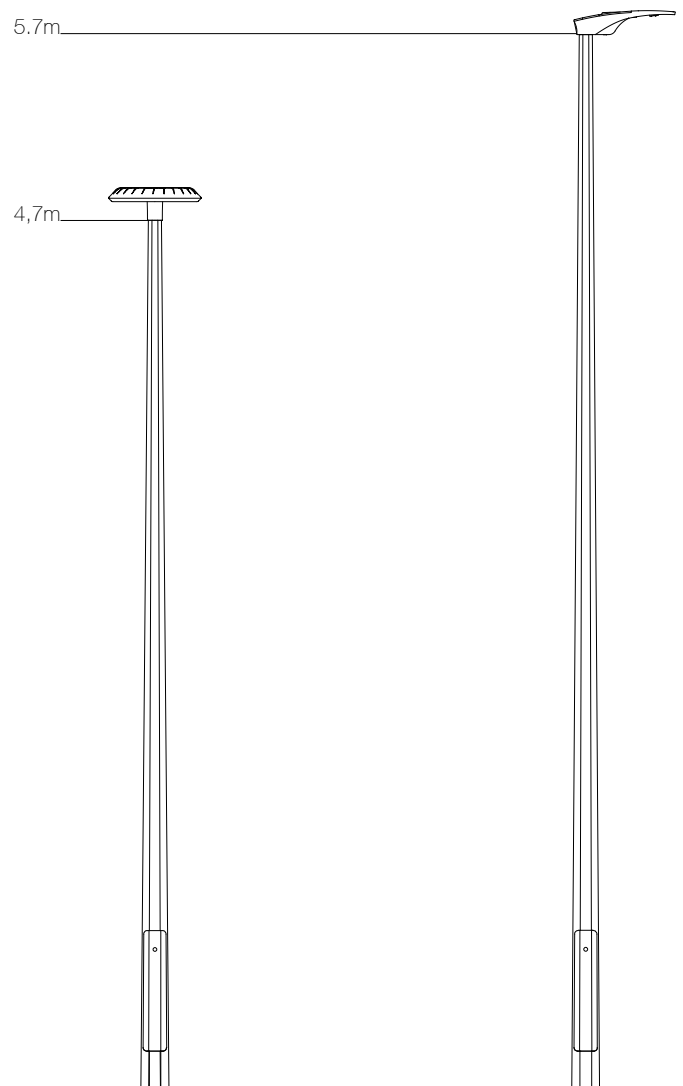



Dimensional Information

Planted Root Option

| Height (m) | BD (mm) | TD (mm) | PD (mm) | DH x DW (mm) | Mass (kg) | OTM (kNm) | Shear (kN) | Min. Concrete Dia. (mm) |
|------------|---------|---------|---------|--------------|-----------|-----------|------------|-------------------------|
| 4,7 | 165 | 70 | 800 | 500 x 100 | 27,5 | 3,332 | 1,251 | 397 |
| 5,7 | 163 | 71 | 1000 | 500 x 100 | 39,7 | 4,286 | 1,45 | 262 |

Headload Capacity Information

| Height (m) | Mounting Arrangement | Projection (m) | Weight (kg) | Extra Light | Light | Medium | Heavy | Extra Heavy |
|------------|----------------------|----------------|-------------|-------------|-------|--------|-------|-------------|
| 4,7 | Single Arm | 0,3 | 10 | 0,27 | 0,21 | 0,17 | 0,14 | 0,07 |
| | Single Arm | 0,3 | 20 | 0,23 | 0,18 | 0,15 | 0,11 | 0,05 |
| | Single Arm | 0,5 | 10 | 0,22 | 0,17 | 0,14 | 0,11 | 0,05 |
| | Single Arm | 0,5 | 20 | 0,19 | 0,14 | 0,11 | 0,09 | 0,02 |
| | Single Arm | 0,8 | 10 | 0,17 | 0,11 | 0,09 | 0,06 | 0,01 |
| | Single Arm | 0,8 | 20 | 0,14 | 0,09 | 0,06 | 0,05 | 0,00 |
| 5,7 | Single Arm | 0,3 | 10 | 0,23 | 0,17 | 0,13 | 0,10 | 0,02 |
| | Single Arm | 0,3 | 20 | 0,19 | 0,14 | 0,10 | 0,07 | 0,01 |
| | Single Arm | 0,5 | 10 | 0,19 | 0,14 | 0,10 | 0,07 | 0,01 |
| | Single Arm | 0,5 | 20 | 0,17 | 0,10 | 0,07 | 0,05 | 0,00 |
| | Single Arm | 0,8 | 10 | 0,14 | 0,09 | 0,06 | 0,03 | 0,00 |
| | Single Arm | 0,8 | 20 | 0,11 | 0,06 | 0,03 | 0,01 | 0,00 |

Dimensions and technical information given as an indication.

See diagrams beginning on page 308 for info regarding the moments and abbreviations used in above tables.

Valmont reserves the right to make, without delay and without prior notice, the technical or aesthetic modifications that it deems necessary to improve the products of the Standard Collection.

Mersey



Description

A 12 sided, multifold, Stainless Steel tapering lighting column. Stainless steel lighting columns deliver excellent value by providing a superb aesthetic appeal, low maintenance, and long life.

Specifications

Columns are available in heights of 8 and 10 metres and can be used for post top applications or supplied with demountable bracket arm arrangements.

Stainless Steel is high strength, lightweight, and 100% recyclable. Stainless Steel lighting columns have been in service for over 30 years with an unequalled track record with regards to corrosion, and offer excellent value when assessing whole life cost. Full material specification can be found on page 26.

Valmont Stainton operates a Quality Assurance system which complies with requirements of BS EN ISO 9001.

Our welders and welding procedures are independently certified in accordance with EN ISO 9606 and EN ISO 15607.

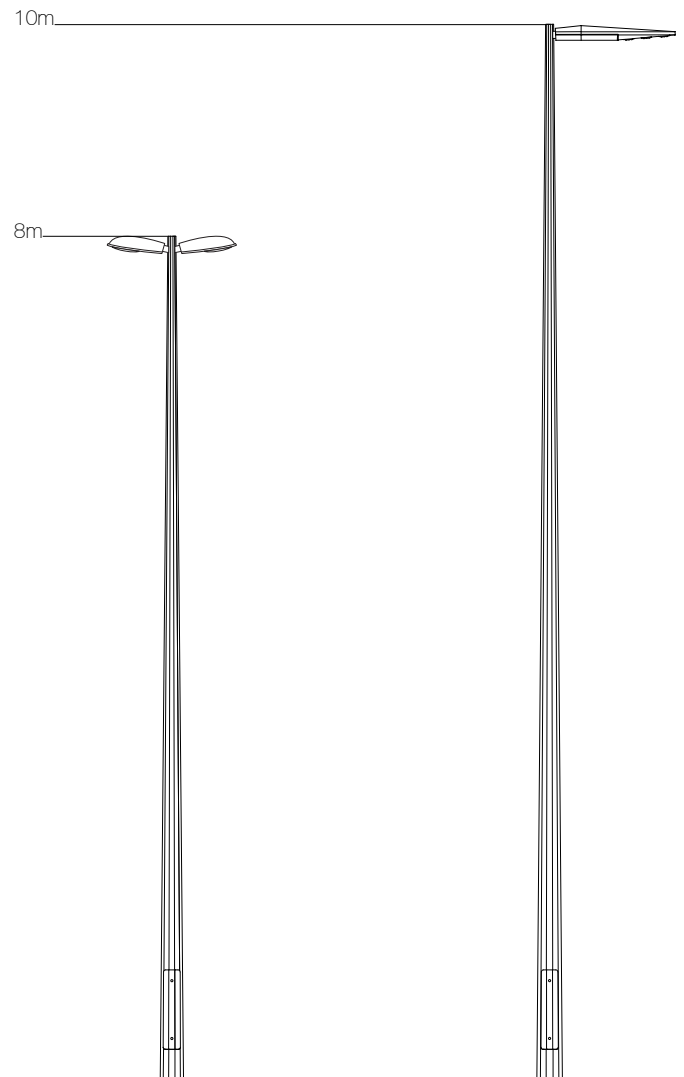



Dimensional Information

Planted Root Option

| Height (m) | BD (mm) | TD (mm) | PD (mm) | DH x DW (mm) | Mass (kg) | OTM (kNm) | Shear (kN) | Min. Concrete Dia. (mm) |
|------------|---------|---------|---------|--------------|-----------|-----------|------------|-------------------------|
| 8 | 242 | 76 | 1200 | 600 x 115 | 78 | 14,33 | 2,40 | 498 |
| 10 | 265 | 76 | 1500 | 600 x 115 | 99 | 16,49 | 2,88 | 294 |

Flange Plated Option

| Height (m) | BD | TD | DH x DW | SL x T x BC | Anchor Bolts | Mass (kg) | OTM (kNm) | Shear (kN) | Concrete Foundation Size |
|------------|-----|----|-----------|----------------|--------------|-----------|-----------|------------|--------------------------|
| 8 | 220 | 76 | 600 x 115 | 420 x 15 x 300 | M24 x 820 | 85 | 14,33 | 2,40 | 500 sq x 1000 h |
| 10 | 239 | 76 | 600 x 115 | 420 x 20 x 300 | M24 x 820 | 107 | 16,49 | 2,88 | 600 sq x 1000 h |

Headload Capacity Information

| Height (m) | Mounting Arrangement | Projection (m) | Weight (kg) | Extra Light | Light | Medium | Heavy | Extra Heavy |
|------------|----------------------|----------------|-------------|-------------|-------|--------|-------|-------------|
| 8 | Single Arm | 0,5 | 20 | 0,40 | 0,40 | 0,40 | 0,40 | 0,36 |
| | Double Arm | 0,5 | 20 | 0,40 | 0,36 | 0,31 | 0,27 | 0,18 |
| | Single Arm | 1,0 | 20 | 0,40 | 0,40 | 0,40 | 0,40 | 0,27 |
| | Double Arm | 1,0 | 20 | 0,39 | 0,31 | 0,27 | 0,23 | 0,14 |
| | Single Arm | 1,5 | 20 | 0,40 | 0,35 | 0,31 | 0,28 | 0,19 |
| | Double Arm | 1,5 | 20 | 0,34 | 0,27 | 0,22 | 0,18 | 0,09 |
| 10 | Single Arm | 0,5 | 20 | 0,40 | 0,40 | 0,40 | 0,34 | 0,19 |
| | Double Arm | 0,5 | 20 | 0,27 | 0,21 | 0,18 | 0,14 | 0,06 |
| | Single Arm | 1,0 | 20 | 0,40 | 0,40 | 0,34 | 0,27 | 0,14 |
| | Double Arm | 1,0 | 20 | 0,23 | 0,17 | 0,13 | 0,10 | 0,02 |
| | Single Arm | 1,5 | 20 | 0,36 | 0,31 | 0,26 | 0,21 | 0,07 |
| | Double Arm | 1,5 | 20 | 0,18 | 0,13 | 0,09 | 0,05 | 0,00 |

Dimensions and technical information given as an indication.

See diagrams beginning on page 308 for info regarding the moments and abbreviations used in above tables.

Valmont reserves the right to make, without delay and without prior notice, the technical or aesthetic modifications that it deems necessary to improve the products of the Standard Collection.

Conway



Description

A conical, Stainless Steel tapering lighting column. Stainless steel lighting columns deliver excellent value by providing a superb aesthetic appeal, low maintenance, and long life.

Specifications

Columns are available in heights of 5 to 10 metres and can be used for post top applications or supplied with demountable bracket arm arrangements.

Stainless Steel is high strength, lightweight, and 100% recyclable. Stainless Steel lighting columns have been in service for over 30 years with an unequalled track record with regards to corrosion, and offer excellent value when assessing whole life cost. Full material specification can be found on page 26.

Valmont Stainton operates a Quality Assurance system which complies with requirements of BS EN ISO 9001.

Our welders and welding procedures are independently certified in accordance with EN ISO 9606 and EN ISO 15607.

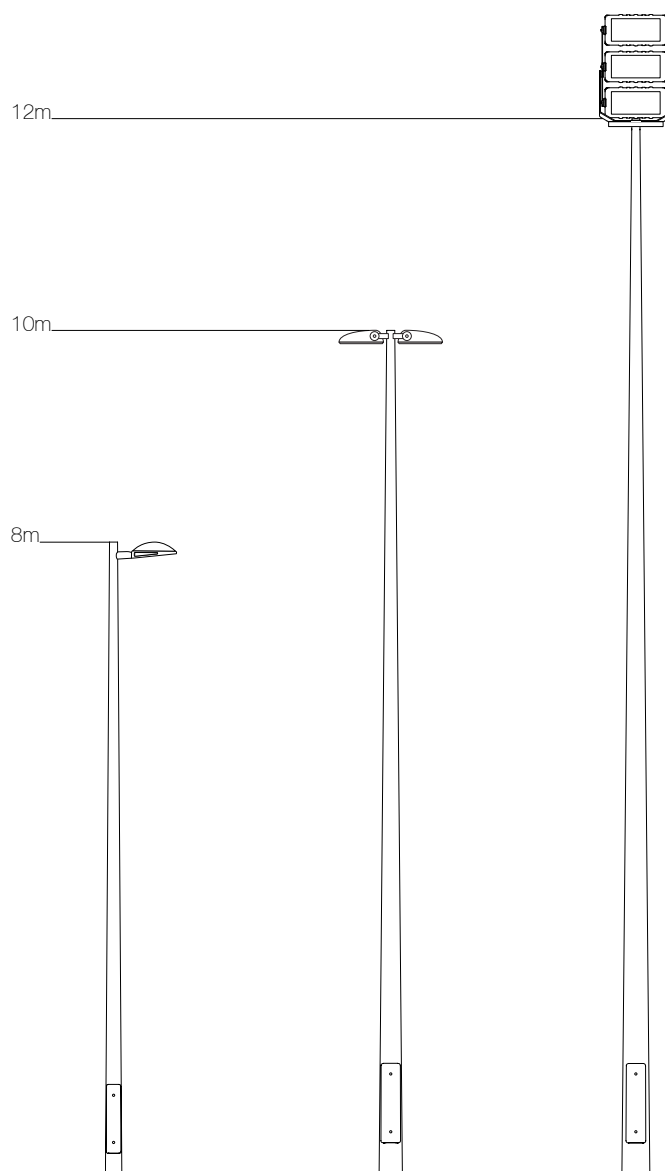



Dimensional Information

Planted Root Option

| Height (m) | BD (mm) | TD (mm) | PD (mm) | DH x DW (mm) | Mass (kg) | OTM (kNm) | Shear (kN) | Min. Concrete Dia. (mm) |
|------------|---------|---------|---------|--------------|-----------|-----------|------------|-------------------------|
| 5 | 150 | 76 | 800 | 500 x 100 | 33 | 3,41 | 0,98 | 403 |
| 6 | 168 | 76 | 1000 | 500 x 100 | 44 | 5,04 | 1,20 | 306 |
| 8 | 249 | 76 | 1200 | 600 x 115 | 72 | 14,24 | 2,39 | 495 |
| 10 | 292 | 76 | 1500 | 600 x 115 | 103 | 18,68 | 2,81 | 333 |

Flange Plated Option

| Height (m) | BD | TD | DH x DW | SL x T x BC | Anchor Bolts | Mass (kg) | OTM (kNm) | Shear (kN) | Concrete Foundation Size |
|------------|-----|----|-----------|----------------|--------------|-----------|-----------|------------|--------------------------|
| 5 | 140 | 76 | 500 x 100 | 280 x 15 x 200 | M18 x 400 | 36 | 3,41 | 0,98 | 400 sq x 500 h |
| 6 | 156 | 76 | 500 x 100 | 280 x 15 x 200 | M18 x 400 | 45 | 5,04 | 1,20 | 400 sq x 600 h |
| 8 | 224 | 76 | 600 x 115 | 420 x 15 x 300 | M24 x 820 | 79 | 14,24 | 2,39 | 500 sq x 1000 h |
| 10 | 264 | 76 | 600 x 115 | 420 x 20 x 300 | M24 x 820 | 109 | 18,68 | 2,81 | 600 sq x 1100 h |

Headload Capacity Information

| Height (m) | Mounting Arrangement | Projection (m) | Weight (kg) | Extra Light | Light | Medium | Heavy | Extra Heavy |
|------------|----------------------|----------------|-------------|-------------|-------|--------|-------|-------------|
| 5 | Single Arm | 0,3 | 20 | 0,28 | 0,23 | 0,21 | 0,18 | 0,11 |
| | Double Arm | 0,3 | 20 | 0,17 | 0,14 | 0,11 | 0,10 | 0,06 |
| | Single Arm | 0,5 | 20 | 0,23 | 0,19 | 0,17 | 0,14 | 0,10 |
| | Double Arm | 0,5 | 20 | 0,17 | 0,13 | 0,10 | 0,09 | 0,05 |
| | Single Arm | 0,75 | 20 | 0,19 | 0,15 | 0,13 | 0,11 | 0,06 |
| | Double Arm | 0,75 | 20 | 0,14 | 0,11 | 0,09 | 0,07 | 0,03 |
| 6 | Single Arm | 0,3 | 20 | 0,36 | 0,30 | 0,26 | 0,23 | 0,17 |
| | Double Arm | 0,3 | 20 | 0,22 | 0,18 | 0,15 | 0,13 | 0,09 |
| | Single Arm | 0,5 | 20 | 0,32 | 0,26 | 0,23 | 0,19 | 0,14 |
| | Double Arm | 0,5 | 20 | 0,21 | 0,17 | 0,14 | 0,11 | 0,07 |
| | Single Arm | 0,75 | 20 | 0,27 | 0,22 | 0,19 | 0,17 | 0,10 |
| | Double Arm | 0,75 | 20 | 0,19 | 0,14 | 0,13 | 0,10 | 0,06 |
| 8 | Single Arm | 0,5 | 20 | 0,40 | 0,40 | 0,40 | 0,40 | 0,40 |
| | Double Arm | 0,5 | 20 | 0,40 | 0,35 | 0,31 | 0,28 | 0,21 |
| | Single Arm | 1,0 | 20 | 0,40 | 0,40 | 0,40 | 0,40 | 0,31 |
| | Double Arm | 1,0 | 20 | 0,38 | 0,31 | 0,27 | 0,23 | 0,17 |
| | Single Arm | 1,5 | 20 | 0,40 | 0,35 | 0,32 | 0,28 | 0,22 |
| | Double Arm | 1,5 | 20 | 0,32 | 0,26 | 0,22 | 0,19 | 0,11 |
| 10 | Single Arm | 0,5 | 20 | 0,40 | 0,40 | 0,40 | 0,40 | 0,38 |
| | Double Arm | 0,5 | 20 | 0,38 | 0,31 | 0,27 | 0,23 | 0,17 |
| | Single Arm | 1,0 | 20 | 0,40 | 0,40 | 0,40 | 0,40 | 0,31 |
| | Double Arm | 1,0 | 20 | 0,32 | 0,26 | 0,23 | 0,19 | 0,11 |
| | Single Arm | 1,5 | 20 | 0,38 | 0,32 | 0,30 | 0,27 | 0,21 |
| | Double Arm | 1,5 | 20 | 0,27 | 0,22 | 0,18 | 0,14 | 0,07 |

Dimensions and technical information given as an indication.

See diagrams beginning on page 308 for info regarding the moments and abbreviations used in above tables.

Valmont reserves the right to make, without delay and without prior notice, the technical or aesthetic modifications that it deems necessary to improve the products of the Standard Collection.

Corten Columns Standard and Bespoke



Project Lead: Tehomet | Installation: Laukaa, Finland

Corten Steel 

Conical Corten
Bespoke Corten



Conical Corten_{Weathering Steel}



Description

Corten is a weather-resistant steel alloy that has been optimized with copper, chromium, nickel and phosphorus.

When exposed to weather, Corten steel develops a rich patina which protects it from corrosion. As Corten weathers its patina gives it an antique, rustic, or industrial feel which has greatly boosted its popularity in recent years.

Specifications

Conical Corten columns are constructed from COR-TEN B S355 steel and are available in mounting heights from 4 to 8 metres.

They can be used for post top applications or supplied with demountable or integral bracket arm arrangements.

Valmont Corten products are designed to meet EN 40-5 standards and carry CE Certification. Valmont Stainton operates a Quality Assurance system which complies with requirements of BS EN ISO 9001.

Our welders and welding procedures are independently certified in accordance with EN ISO 9606 and EN ISO 15607.

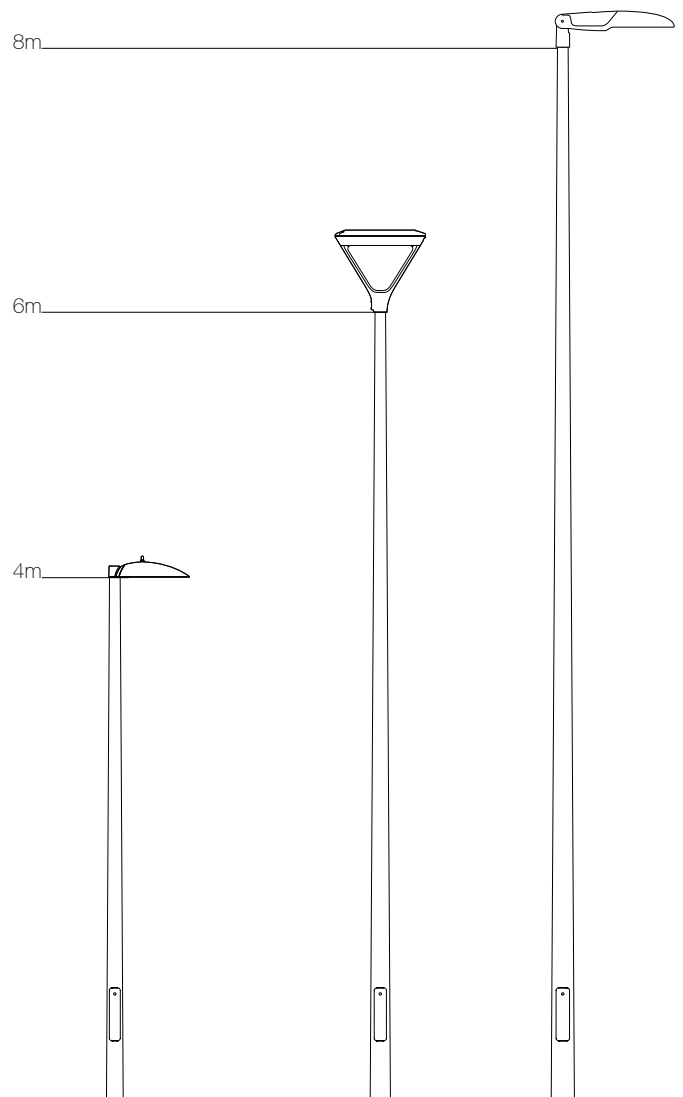



Dimensional Information

Planted Root Option

| Height (m) | BD (mm) | TD (mm) | PD (mm) | DH x DW (mm) | Mass (kg) | OTM (kNm) | Shear (kN) | Min. Concrete Dia. (mm) |
|------------|---------|---------|---------|--------------|-----------|-----------|------------|-------------------------|
| 4 | 132 | 76 | 800 | 400 x 80 | 47 | 9,48 | 2,60 | 957 |
| 5 | 146 | 76 | 800 | 400 x 80 | 61 | 12,50 | 2,79 | 1231 |
| 6 | 160 | 76 | 1000 | 400 x 90 | 79 | 14,00 | 2,67 | 709 |
| 8 | 184 | 76 | 1200 | 400 x 100 | 114 | 18,65 | 2,82 | 541 |

Flange Plated Option

| Height (m) | BD | TD | DH x DW | SL x T x BC | Anchor Bolts | Mass (kg) | OTM (kNm) | Shear (kN) | Concrete Foundation Size |
|------------|-----|----|-----------|----------------|--------------|-----------|-----------|------------|--------------------------|
| 4 | 123 | 76 | 400 x 80 | 300 x 12 x 200 | M18/20 x 400 | 45 | 9,48 | 2,60 | 500 sq x 800 h |
| 5 | 134 | 76 | 400 x 80 | 300 x 12 x 200 | M18/20 x 400 | 57 | 12,50 | 2,79 | 500 sq x 1000 h |
| 6 | 148 | 76 | 400 x 90 | 300 x 12 x 200 | M18/20 x 400 | 71 | 14,00 | 2,67 | 500 sq x 1000 h |
| 8 | 170 | 76 | 400 x 100 | 400 x 15 x 300 | M24 x 500 | 110 | 18,65 | 2,82 | 600 sq x 1100 h |

Headload Capacity Information

| Height (m) | Mounting Arrangement | Projection (m) | Weight (kg) | Extra Light | Light | Medium | Heavy | Extra Heavy |
|------------|----------------------|----------------|-------------|-------------|-------|--------|-------|-------------|
| 4 | Post Top | N/A | 60 | 2,52 | 2,20 | 2,02 | 1,85 | 1,48 |
| 5 | Post Top | N/A | 60 | 2,41 | 2,10 | 1,93 | 1,76 | 1,40 |
| 6 | Post Top | N/A | 30 | 2,19 | 1,91 | 1,75 | 1,59 | 1,25 |
| 8 | Post Top | N/A | 30 | 1,42 | 1,24 | 1,13 | 1,02 | 0,80 |

Dimensions and technical information given as an indication.

See diagrams beginning on page 308 for info regarding the moments and abbreviations used in above tables.

Valmont reserves the right to make, without delay and without prior notice, the technical or aesthetic modifications that it deems necessary to improve the products of the Standard Collection.

Bespoke Corten Weathering Steel

The Softer Side of Steel.

Weathering steel has been around for decades, but has seen a sharp rise in popularity in recent years.

Weathering steel was first used in architectural projects, but today it is commonly seen in residential houses, urban furniture, and even lighting columns.

Valmont Stainton has a talented team of designers and engineers that are standing by to help you make your corten concepts a reality.



Curved Columns.

Valmont Stainton has offered curved columns in galvanised steel, aluminium, and even wood for many years. Today, we add corten steel to that material list.

Curving corten columns can add a playful and organic aesthetic to this traditionally industrial feeling material.



Mixing Materials for Aesthetic Effect.

Weathering steel can be used as an accent material to highlight aspects of a design or to transform a standard product into something unique and extraordinary.

Corten can be used in combination with galvanised steel, stainless steel, and even wood. The limits of these combinations are endless!



Hinged Columns



Project Lead: Stockton Council | Installation: Leven Park Walkway



Hinged Columns

Leven
Trent
Swale
Tay
Derwent
Dart
ROTA
Tyne
Humber



Leven

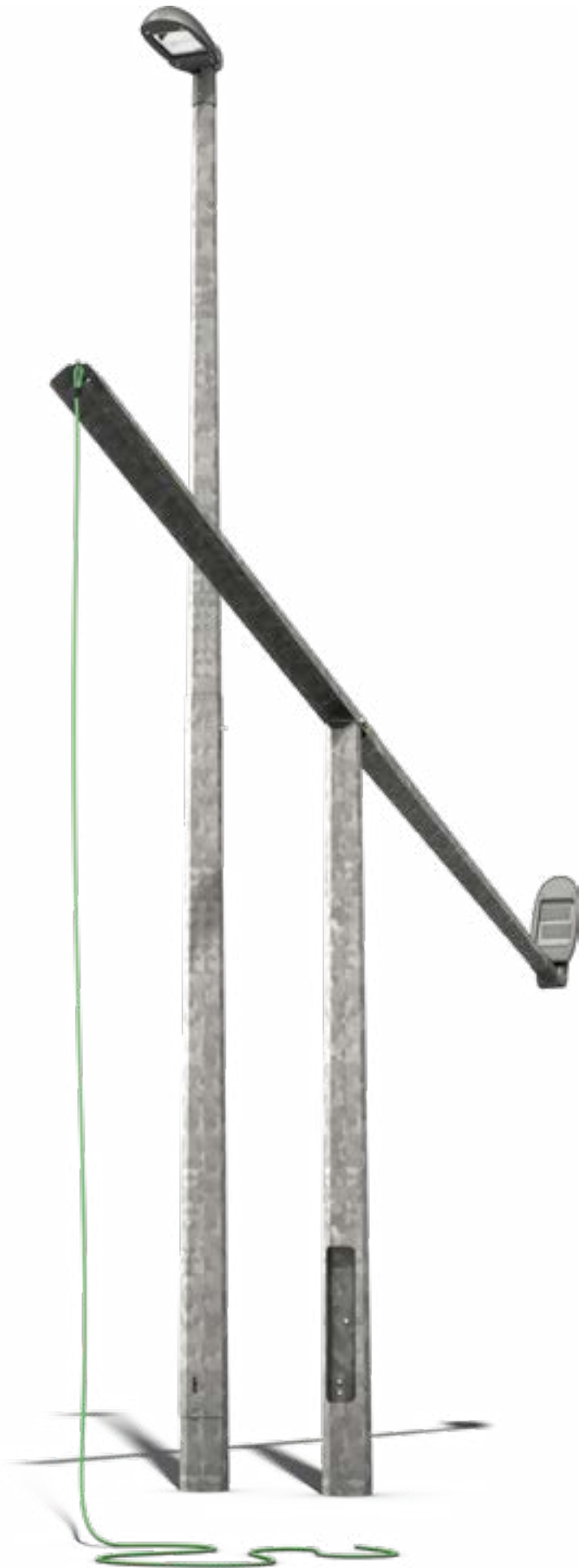

Description

A Mid-hinged octagonal galvanised steel lighting column. Raising and lowering the column is a one man operation without the need of specialist equipment.

Specifications

5 & 6M Column mounting heights available. Leven columns can be used for post top applications or supplied with demountable bracket arm arrangements.

The columns are equipped with a unique triple-locking device to prevent accidental lowering of the column.

The standard corrosion protection system is hot dip galvanised to BS EN 1461. In addition, a variety of root treatments and full paint specification options are available.

Valmont Stainton operates a Quality Assurance system which complies with requirements of BS EN ISO 9001.

Our welders and welding procedures are independently certified in accordance with EN ISO 9606 and EN ISO 15607.

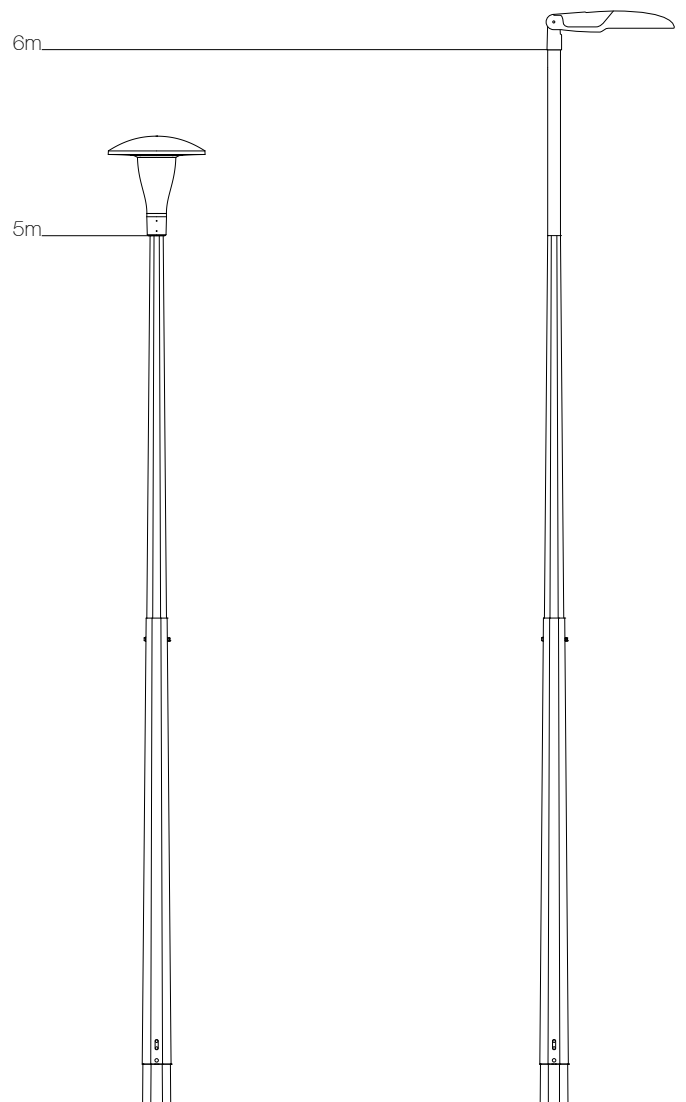

Dimensional Information

Planted Root Option

| Height (m) | BD (mm) | TD (mm) | PD (mm) | DH x DW (mm) | Mass (kg) | OTM (kNm) | Shear (kN) | Min. Concrete Dia. (mm) |
|------------|---------|---------|---------|--------------|-----------|-----------|------------|-------------------------|
| 5 | 165 | 76 | 800 | 500 x 100 | 51 | 5,53 | 1,70 | 653 |
| 6 | 165 | 76 | 800 | 500 x 100 | 55 | 5,67 | 1,66 | 659 |

Flange Plated Option

| Height (m) | BD (mm) | TD (mm) | DH x DW (mm) | SL x T x BC (mm) | Anchor Bolts | Mass (kg) | OTM (kNm) | Shear (kN) | Concrete Foundation Sizes (mm) |
|------------|---------|---------|--------------|------------------|--------------|-----------|-----------|------------|--------------------------------|
| 5 | 165 | 76 | 500 x 100 | 260 x 15 x 200 | M18 x 400 | 50 | 5,53 | 1,70 | 400 sq x 700 h |
| 6 | 165 | 76 | 500 x 100 | 260 x 15 x 200 | M18 x 400 | 55 | 5,67 | 1,66 | 400 sq x 700 h |

Headload Capacity Information

| Height (m) | Mounting Arrangement | Projection (m) | Weight (kg) | Extra Light (m ²) | Light (m ²) | Medium (m ²) | Heavy (m ²) | Extra Heavy (m ²) |
|------------|----------------------|----------------|-------------|-------------------------------|-------------------------|--------------------------|-------------------------|-------------------------------|
| 5 | Post Top | N/A | 15 | 0,95 | 0,81 | 0,73 | 0,65 | 0,49 |
| 6 | Post Top | N/A | 15 | 0,67 | 0,56 | 0,50 | 0,43 | 0,31 |

Dimensions and technical information given as an indication.

See diagrams beginning on page 308 for info regarding the moments and abbreviations used in above tables.

Valmont reserves the right to make, without delay and without prior notice, the technical or aesthetic modifications that it deems necessary to improve the products of the Standard Collection.

Trent

Description

A Mid-hinged tubular lighting column which is designed with simplicity in mind. Raising and lowering the column is a one man see-saw operation which requires no special tools.

Specifications

Column heights range from 4-12 metres.

They can be used for post top applications or supplied with demountable bracket arm arrangements.

The columns are equipped with a unique triple-locking device to prevent accidental lowering of the column.

The standard corrosion protection system is hot dip galvanised to BS EN 1461. In addition, a variety of root treatments and full paint specification options are available.

Valmont Stainton operates a Quality Assurance system which complies with requirements of BS EN ISO 9001.

Our welders and welding procedures are independently certified in accordance with EN ISO 9606 and EN ISO 15607.

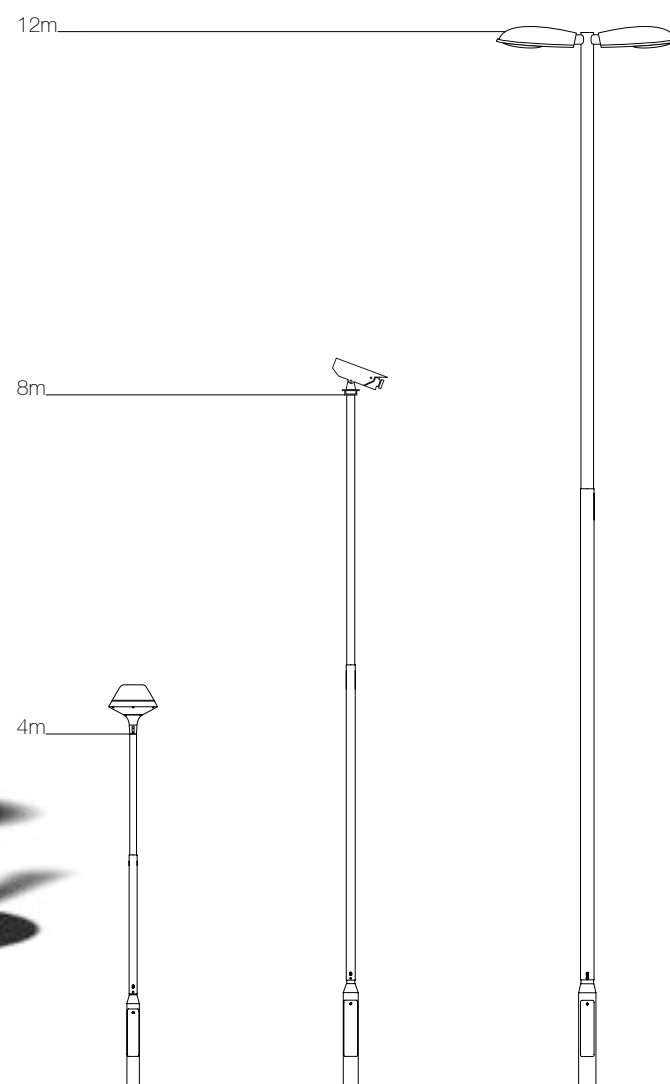

Dimensional Information

Planted Root Option

| Height (m) | BD (mm) | SK D (mm) | SD (mm) | PD (mm) | BH (mm) | SH (mm) | DH x DW (mm) | Mass (kg) | OTM (kNm) | Shear (kN) | Min. Concrete Dia. (mm) |
|------------|---------|-----------|---------|---------|---------|---------|--------------|-----------|-----------|------------|-------------------------|
| 4 | 139,7 | 88,9 | 76,1 | 800 | 1075 | 2925 | 500 x 100 | 45 | 3,80 | 1,48 | 458 |
| 5 | 139,7 | 88,9 | 76,1 | 800 | 1075 | 3925 | 500 x 100 | 56 | 3,26 | 1,02 | 386 |
| 6 | 139,7 | 88,9 | 76,1 | 1000 | 1075 | 4925 | 500 x 100 | 68 | 5,60 | 1,36 | 340 |
| 8 | 168,3 | 101,6 | 88,9 | 1200 | 1200 | 6800 | 600 x 115 | 116 | 7,60 | 1,70 | 265 |
| 10 | 168,3 | 127 | 114,3 | 1500 | 1200 | 8800 | 600 x 115 | 184 | 12,28 | 2,02 | 219 |
| 12 | 193,7 | 152,4 | 139,7 | 1700 | 1200 | 10800 | 600 x 115 | 255 | 20,28 | 3,50 | 248 |

Flange Plated Option

| Height (m) | BD (mm) | SK D (mm) | SD (mm) | BH (mm) | SH (mm) | DH x DW (mm) | SL x T x BC (mm) | Anchor Bolts | Mass (kg) | OTM (kNm) | Shear (kN) | Concrete Foundation Sizes (mm) |
|------------|---------|-----------|---------|---------|---------|--------------|------------------|--------------|-----------|-----------|------------|--------------------------------|
| 4 | 139,7 | 88,9 | 76,1 | 1075 | 2925 | 500 x 100 | 260 x 15 x 200 | M18 x 400 | 42 | 3,80 | 1,48 | 400 sq x 600 h |
| 5 | 139,7 | 88,9 | 76,1 | 1075 | 3925 | 500 x 100 | 260 x 15 x 200 | M18 x 400 | 50 | 3,26 | 1,02 | 400 sq x 500 h |
| 6 | 139,7 | 88,9 | 76,1 | 1075 | 4925 | 500 x 100 | 260 x 15 x 200 | M18 x 400 | 65 | 5,60 | 1,36 | 400 sq x 700 h |
| 8 | 168,3 | 101,6 | 88,9 | 1200 | 6590 | 600 x 115 | 420 x 20 x 300 | M24 x 820 | 124 | 7,61 | 1,70 | 400 sq x 800 h |
| 10 | 168,3 | 127 | 114,3 | 1200 | 8630 | 600 x 115 | 420 x 20 x 300 | M24 x 820 | 185 | 12,29 | 2,02 | 500 sq x 1000 h |
| 12 | 193,7 | 152,4 | 139,7 | 1200 | 10645 | 600 x 115 | 420 x 20 x 300 | M24 x 820 | 251 | 20,35 | 3,60 | 600 sq x 1200 h |

Headload Capacity Information

| Height (m) | Mounting Arrangement | Projection (m) | Weight (kg) | Extra Light (m ²) | Light (m ²) | Medium (m ²) | Heavy (m ²) | Extra Heavy (m ²) |
|------------|----------------------|----------------|-------------|-------------------------------|-------------------------|--------------------------|-------------------------|-------------------------------|
| 4 | Post Top | N/A | 20 | 0,7 | 0,59 | 0,53 | 0,47 | 0,35 |
| | Single Arm | 0,5 | 20 | 0,41 | 0,35 | 0,30 | 0,26 | 0,18 |
| | Double Arm | 0,5 | 20 | 0,27 | 0,22 | 0,19 | 0,16 | 0,11 |
| 5 | Post Top | N/A | 20 | 0,42 | 0,36 | 0,32 | 0,27 | 0,19 |
| | Single Arm | 0,5 | 20 | 0,26 | 0,21 | 0,18 | 0,15 | 0,08 |
| | Double Arm | 0,5 | 20 | 0,15 | 0,11 | 0,09 | 0,07 | 0,03 |
| 6 | Post Top | N/A | 20 | 0,66 | 0,55 | 0,49 | 0,43 | 0,31 |
| | Single Arm | 0,5 | 20 | 0,41 | 0,34 | 0,30 | 0,26 | 0,16 |
| | Double Arm | 0,5 | 20 | 0,25 | 0,20 | 0,17 | 0,14 | 0,08 |
| 8 | Post Top | N/A | 20 | 0,44 | 0,35 | 0,30 | 0,25 | 0,15 |
| | Single Arm | 0,5 | 15 | 0,33 | 0,25 | 0,20 | 0,17 | 0,08 |
| | Double Arm | 0,5 | 15 | 0,15 | 0,10 | 0,08 | 0,06 | 0,01 |
| 10 | Post Top | N/A | 20 | 0,48 | 0,39 | 0,34 | 0,29 | 0,20 |
| | Single Arm | 0,5 | 15 | 0,38 | 0,30 | 0,26 | 0,21 | 0,13 |
| | Double Arm | 0,5 | 15 | 0,17 | 0,13 | 0,10 | 0,08 | 0,04 |
| 12 | Post Top | N/A | 15 | 0,67 | 0,56 | 0,51 | 0,45 | 0,37 |
| | Single Arm | 0,5 | 15 | 0,51 | 0,42 | 0,38 | 0,33 | 0,25 |
| | Double Arm | 0,5 | 15 | 0,24 | 0,19 | 0,16 | 0,14 | 0,10 |

Dimensions and technical information given as an indication.

See diagrams beginning on page 308 for info regarding the moments and abbreviations used in above tables.

Valmont reserves the right to make, without delay and without prior notice, the technical or aesthetic modifications that it deems necessary to improve the products of the Standard Collection.

Swale



Description

A Mid-hinged, Stainless Steel conical lighting column which is designed with simplicity in mind. Raising and lowering the column is a one man see-saw operation which requires no special tools.

Specifications

Columns are available in heights of 5 and 6 metres and are equipped with a unique triple-locking device to prevent accidental lowering of the column.

Stainless Steel is high strength, lightweight, and 100% recyclable. Stainless Steel lighting column have been in service for over 30 years with an unequalled track record with regards to corrosion, and offer excellent value when assessing whole life cost. Full material specification can be found on page 26.

Valmont Stainton operates a Quality Assurance system which complies with requirements of BS EN ISO 9001.

Our welders and welding procedures are independently certified in accordance with EN ISO 9606 and EN ISO 15607.

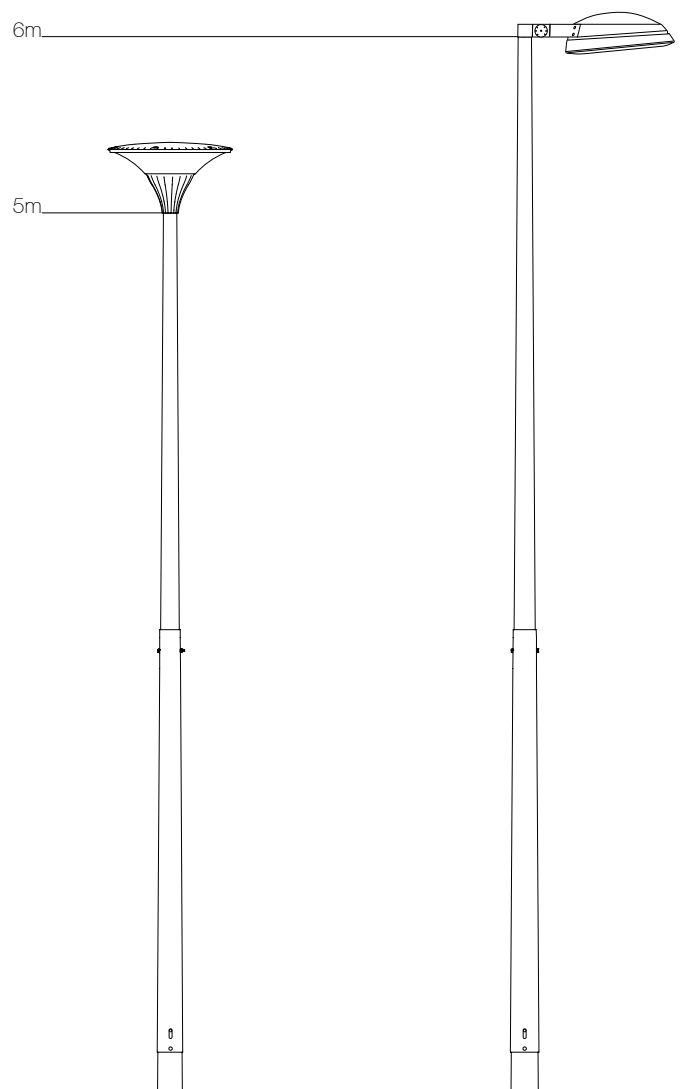

Dimensional Information

Planted Root Option

| Height (m) | BD (mm) | TD (mm) | PD (mm) | DH x DW (mm) | Mass (kg) | OTM (kNm) | Shear (kN) | Min. Concrete Dia. (mm) |
|------------|---------|---------|---------|--------------|-----------|-----------|------------|-------------------------|
| 5 | 150 | 76 | 800 | 500 x 100 | 45 | 6 | 1,54 | 707 |
| 6 | 169 | 76 | 1000 | 500 x 100 | 55 | 7,31 | 1,64 | 444 |

Flange Plated Option

| Height (m) | BD (mm) | TD (mm) | DH x DW (mm) | SL x T x BC (mm) | Anchor Bolts | Mass (kg) | OTM (kNm) | Shear (kN) | Concrete Foundation Sizes (mm) |
|------------|---------|---------|--------------|------------------|--------------|-----------|-----------|------------|--------------------------------|
| 5 | 139,7 | 88,9 | 500 x 100 | 260 x 15 x 200 | M18 x 400 | 50 | 3,26 | 1,02 | 400 sq x 500 h |
| 6 | 139,7 | 88,9 | 500 x 100 | 260 x 15 x 200 | M18 x 400 | 65 | 5,60 | 1,36 | 400 sq x 700 h |

Headload Capacity Information

| Height (m) | Mounting Arrangement | Projection (m) | Weight (kg) | Extra Light (m ²) | Light (m ²) | Medium (m ²) | Heavy (m ²) | Extra Heavy (m ²) |
|------------|----------------------|----------------|-------------|-------------------------------|-------------------------|--------------------------|-------------------------|-------------------------------|
| 5 | Post Top | N/A | 15 | 1,14 | 0,98 | 0,89 | 0,81 | 0,62 |
| 6 | Post Top | N/A | 20 | 1,04 | 0,89 | 0,81 | 0,73 | 0,55 |

Dimensions and technical information given as an indication.

See diagrams beginning on page 308 for info regarding the moments and abbreviations used in above tables.

Valmont reserves the right to make, without delay and without prior notice, the technical or aesthetic modifications that it deems necessary to improve the products of the Standard Collection.

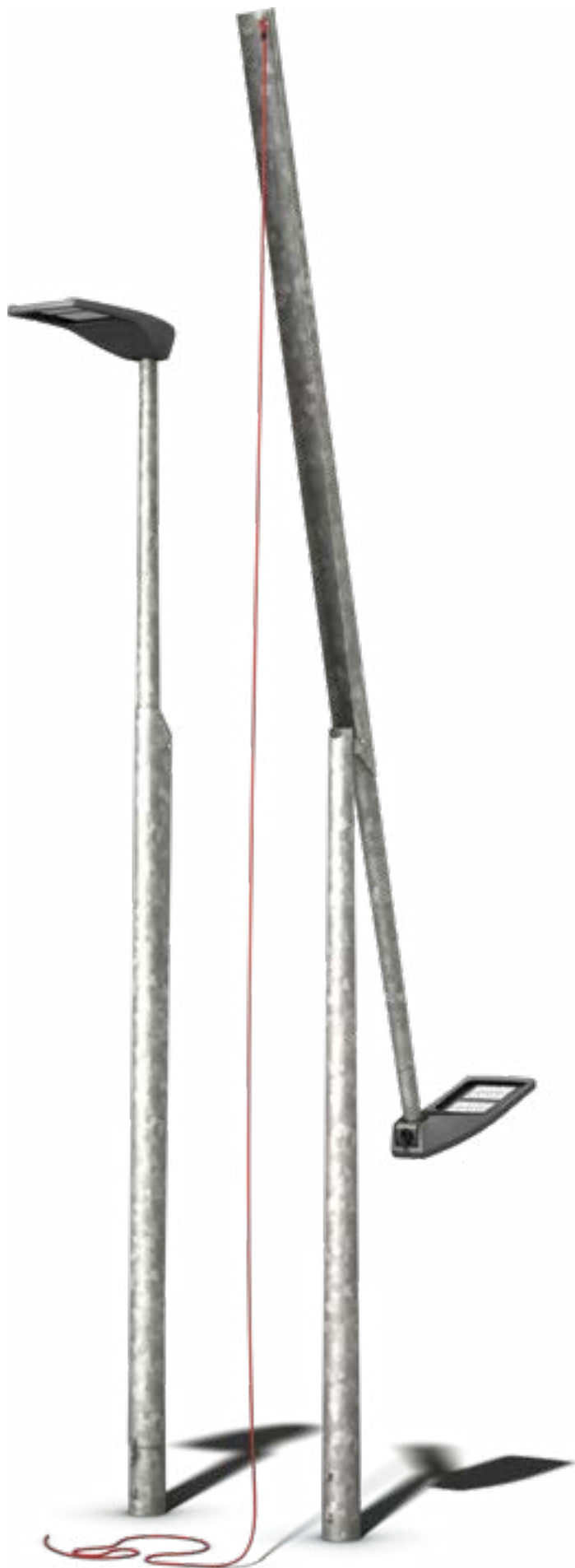

Description

A Mid-hinged conical lighting column which is designed with simplicity in mind. Raising and lowering the column is a one man see-saw operation which requires no special tools.

Specifications

Column heights range from 4 to 6 metres and are suitable for post top applications.

The columns are equipped with a unique triple-locking device to prevent accidental lowering of the column.

The standard corrosion protection system is hot dip galvanised to BS EN 1461. In addition, a variety of root treatments and full paint specification options are available.

Valmont Stainton operates a Quality Assurance system which complies with requirements of BS EN ISO 9001.

Our welders and welding procedures are independently certified in accordance with EN ISO 9606 and EN ISO 15607.

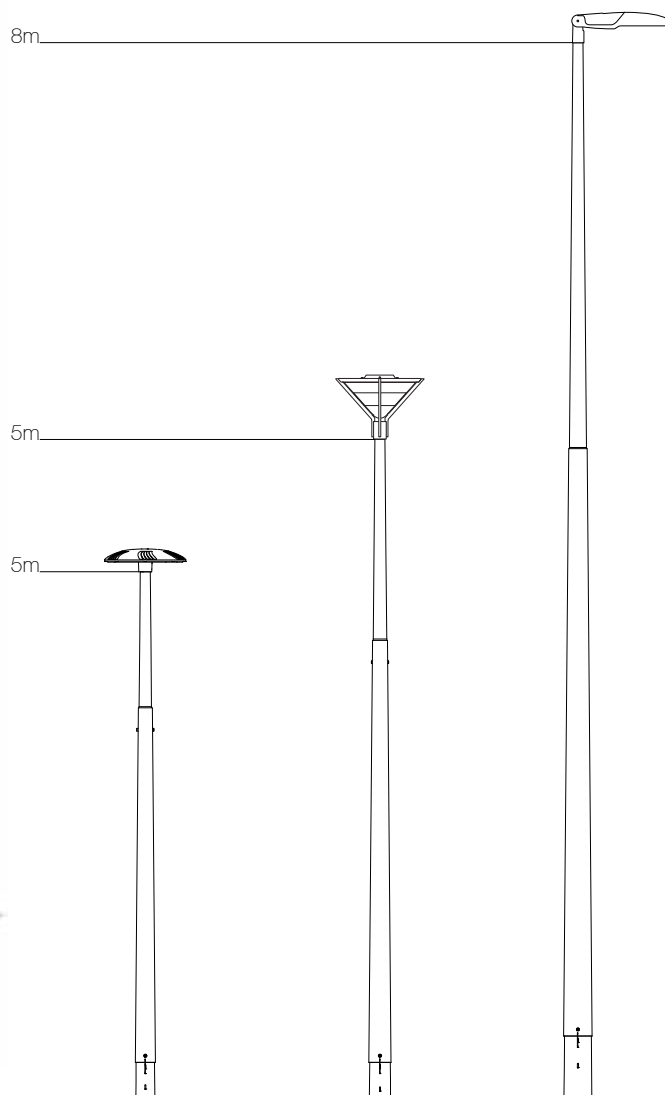

Dimensional Information

Planted Root Option

| Height (m) | BD (mm) | TD (mm) | PD (mm) | DH x DW (mm) | Mass (kg) | OTM (kNm) | Shear (kN) | Min. Concrete Dia. (mm) |
|------------|---------|---------|---------|--------------|-----------|-----------|------------|-------------------------|
| 4 | 158 | 76 | 800 | 500 x 100 | 75 | 7,49 | 2,17 | 760 |
| 5 | 175 | 76 | 800 | 500 x 100 | 92 | 10,64 | 2,48 | 1050 |
| 6 | 195 | 76 | 1000 | 500 x 100 | 119 | 14,08 | 2,87 | 720 |
| 8 | 232 | 76 | 1200 | 500 x 100 | 192 | 21,79 | 3,59 | 640 |

Flange Plated Option

| Height (m) | BD (mm) | TD (mm) | DH x DW (mm) | SL x T x BC (mm) | Anchor Bolts | Mass (kg) | OTM (kNm) | Shear (kN) | Concrete Foundation Sizes (mm) |
|------------|---------|---------|--------------|------------------|--------------|-----------|-----------|------------|--------------------------------|
| 4 | 144 | 76 | 500 x 100 | 260 x 15 x 200 | M18 x 400 | 67 | 7,49 | 2,17 | 400 sq x 800 h |
| 5 | 161 | 76 | 500 x 100 | 260 x 15 x 200 | M18 x 400 | 83 | 10,64 | 2,48 | 500 sq x 900 h |
| 6 | 178 | 76 | 500 x 100 | 260 x 20 x 200 | M18 x 400 | 105 | 14,08 | 2,87 | 500 sq x 1000 h |
| 8 | 212 | 76 | 500 x 100 | 420 x 20 x 300 | M24 x 820 | 169 | 21,79 | 3,59 | 600 sq x 1200 h |

Headload Capacity Information

| Height (m) | Mounting Arrangement | Projection (m) | Weight (kg) | Extra Light (m ²) | Light (m ²) | Medium (m ²) | Heavy (m ²) | Extra Heavy (m ²) |
|------------|----------------------|----------------|-------------|-------------------------------|-------------------------|--------------------------|-------------------------|-------------------------------|
| 4 | Post Top Side | N/A | 25 | 1,13 | 0,98 | 0,90 | 0,82 | 0,65 |
| | Post Top | N/A | 60 | 1,76 | 1,54 | 1,41 | 1,29 | 1,01 |
| | Single Arm | 0,5 | 25 | 0,61 | 0,53 | 0,48 | 0,44 | 0,34 |
| | Double Arm | 0,5 | 25 | 0,81 | 0,70 | 0,64 | 0,58 | 0,45 |
| 5 | Post Top Side | N/A | 25 | 1,55 | 1,35 | 1,24 | 1,12 | 0,89 |
| | Post Top | N/A | 60 | 2,00 | 1,74 | 1,58 | 1,45 | 1,13 |
| | Single Arm | 0,5 | 25 | 0,97 | 0,84 | 0,77 | 0,69 | 0,54 |
| | Double Arm | 0,5 | 25 | 0,93 | 0,80 | 0,73 | 0,66 | 0,51 |
| 6 | Post Top Side | N/A | 25 | 1,85 | 1,61 | 1,48 | 1,35 | 1,06 |
| | Post Top | N/A | 60 | 2,15 | 1,86 | 1,70 | 1,54 | 1,23 |
| | Single Arm | 0,5 | 25 | 1,28 | 1,11 | 1,01 | 0,92 | 0,71 |
| | Double Arm | 0,5 | 25 | 1,01 | 0,87 | 0,79 | 0,72 | 0,55 |
| 8 | Post Top Side | N/A | 25 | 1,60 | 1,39 | 1,27 | 1,15 | 0,91 |
| | Post Top | N/A | 60 | 1,70 | 1,49 | 1,35 | 1,23 | 0,96 |
| | Single Arm | 0,5 | 25 | 1,23 | 1,06 | 0,97 | 0,87 | 0,68 |
| | Double Arm | 0,5 | 25 | 0,79 | 0,68 | 0,62 | 0,56 | 0,42 |
| | Single Arm | 1 | 25 | 0,75 | 0,66 | 0,61 | 0,55 | 0,44 |
| | Double Arm | 1 | 25 | 0,74 | 0,63 | 0,57 | 0,51 | 0,38 |

Dimensions and technical information given as an indication.

See diagrams beginning on page 308 for info regarding the moments and abbreviations used in above tables.

Valmont reserves the right to make, without delay and without prior notice, the technical or aesthetic modifications that it deems necessary to improve the products of the Standard Collection.

Derwent



Description

A Mid-hinged octagonal lighting column designed around a simple see-saw principle allowing the column lower into its own footprint.

Specifications

Column heights range from 6 to 18 metres and can be used for post top applications or supplied with demountable bracket arm arrangements.

Raising and lowering operation is achieved by either a simple rope for lower capacities or by a manual winch system where larger headweights are required. The headweight table details which lowering mechanisms is required with each headload capacity.

The standard corrosion protection system is hot dip galvanised to BS EN 1461. In addition, a variety of root treatments and full paint specification options are available.

Valmont Stainton operates a Quality Assurance system which complies with requirements of BS EN ISO 9001.

Our welders and welding procedures are independently certified in accordance with EN ISO 9606 and EN ISO 15607.

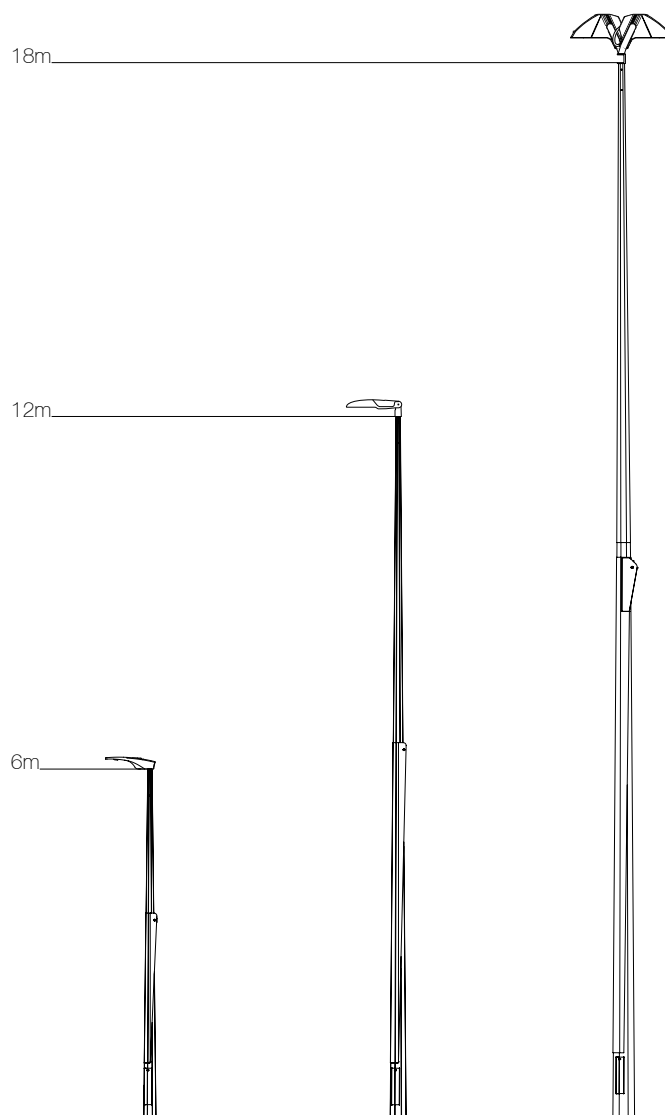

Dimensional Information

Planted Root Option

| Height (m) | BD (mm) | TD (mm) | PD (mm) | DH x DW (mm) | Mass (kg) | OTM (kNm) | Shear (kN) | Min. Concrete Dia. (mm) |
|------------|---------|---------|---------|--------------|-----------|-----------|------------|-------------------------|
| 6 | 212 | 76 | 1000 | 600 x 135 | 125 | 23,6 | 4,92 | 1430 |
| 8 | 212 | 76 | 1200 | 600 x 135 | 175 | 24,87 | 5,2 | 870 |
| 10 | 255 | 76 | 1500 | 600 x 135 | 240 | 42,02 | 6,49 | 750 |
| 12 | 272 | 76 | 1700 | 600 x 135 | 360 | 67,02 | 8,48 | 820 |
| 15 | 346 | 102 | 2000 | 600 x 135 | 580 | 121,15 | 12,87 | 901 |
| 18 | 398 | 102 | 2000 | 600 x 135 | 840 | 143,96 | 13,37 | 1055 |

Flange Plated Option

| Height (m) | BD (mm) | TD (mm) | DH x DW (mm) (2 No.) | Square/Circular Flange | SL x T x BC (mm) | D x T x P.C.D (mm) (Circular) | Anchor Bolts | Mass (kg) | OTM (kNm) | Shear (kN) | Concrete Foundation Sizes (mm) |
|------------|---------|---------|----------------------|------------------------|------------------|-------------------------------|--------------|-----------|-----------|------------|--------------------------------|
| 4 | 212 | 76 | 600 x 135 | Square | 420 x 25 x 300 | N/A | M24 x 820 | 125 | 23,6 | 4,92 | 900 sq x 1100 h |
| 5 | 212 | 76 | 600 x 135 | Square | 420 x 25 x 300 | N/A | M24 x 820 | 175 | 24,87 | 5,2 | 900 sq x 1200 h |
| 6 | 255 | 76 | 600 x 135 | Square | 420 x 25 x 300 | N/A | M24 x 820 | 240 | 42,02 | 6,49 | 1000 sq x 1500 h |
| 8 | 272 | 76 | 600 x 135 | Square | 430 x 30 x 300 | N/A | M30 x 1070 | 360 | 67,02 | 8,48 | 1400 sq x 1500 h |
| 10 | 346 | 102 | 600 x 135 | Circular | N/A | 530 x 30 x 450 | M24 x 820 | 580 | 121,15 | 12,87 | 1500 sq x 2200 h |
| 12 | 398 | 102 | 600 x 135 | Circular | N/A | 600 x 30 x 520 | M24 x 820 | 840 | 143,96 | 13,37 | 1500 sq x 2500 h |

Headload Capacity Information

| Height (m) | Design Capacities & Lowering Method | Weight (kg) | Extra Light (m ²) | Light (m ²) | Medium (m ²) | Heavy (m ²) | Extra Heavy (m ²) |
|------------|-------------------------------------|-------------|-------------------------------|-------------------------|--------------------------|-------------------------|-------------------------------|
| 6 | Minimum | 15 | 2,50 | 2,20 | 2,10 | 2,10 | 1,70 |
| | Max - Rope | 20 | 2,50 | 2,20 | 2,10 | 2,10 | 1,70 |
| | Max - Rope & Pulley | 28 | 2,50 | 2,20 | 2,10 | 2,10 | 1,70 |
| | Max - Winch | 150 | 2,50 | 2,20 | 2,10 | 2,10 | 1,70 |
| 8 | Minimum | 15 | 2,05 | 1,55 | 1,40 | 1,25 | 0,95 |
| | Max - Rope | 28 | 2,05 | 1,55 | 1,40 | 1,25 | 0,95 |
| | Max - Rope & Pulley | 36 | 2,05 | 1,55 | 1,40 | 1,25 | 0,95 |
| | Max - Winch | 150 | 2,05 | 1,55 | 1,40 | 1,25 | 0,95 |
| 10 | Minimum | 15 | 2,20 | 1,75 | 1,60 | 1,40 | 0,97 |
| | Max - Rope | 28 | 2,20 | 1,75 | 1,60 | 1,40 | 0,97 |
| | Max - Rope & Pulley | 36 | 2,20 | 1,75 | 1,60 | 1,40 | 0,97 |
| | Max - Winch | 150 | 2,20 | 1,75 | 1,60 | 1,40 | 0,97 |
| 12 | Minimum | 25 | 2,90 | 2,20 | 2,00 | 1,80 | 1,30 |
| | Max - Rope | 28 | 2,90 | 2,20 | 2,00 | 1,80 | 1,30 |
| | Max - Rope & Pulley | 36 | 2,90 | 2,20 | 2,00 | 1,80 | 1,30 |
| | Max - Winch | 150 | 2,90 | 2,20 | 2,00 | 1,80 | 1,30 |
| 15 | Minimum | 30 | 3,80 | 3,10 | 2,70 | 2,40 | 1,70 |
| | Max - Rope | N/A | 3,80 | 3,10 | 2,70 | 2,40 | 1,70 |
| | Max - Rope & Pulley | N/A | 3,80 | 3,10 | 2,70 | 2,40 | 1,70 |
| | Max - Winch | 150 | 3,80 | 3,10 | 2,70 | 2,40 | 1,70 |
| 18 | Minimum | 50 | 2,50 | 2,20 | 2,00 | 1,65 | 1,00 |
| | Max - Rope | N/A | 2,50 | 2,20 | 2,00 | 1,65 | 1,00 |
| | Max - Rope & Pulley | N/A | 2,50 | 2,20 | 2,00 | 1,65 | 1,00 |
| | Max - Winch | 180 | 2,50 | 2,20 | 2,00 | 1,65 | 1,00 |

Dimensions and technical information given as an indication.

See diagrams beginning on page 308 for info regarding the moments and abbreviations used in above tables.

Valmont reserves the right to make, without delay and without prior notice, the technical or aesthetic modifications that it deems necessary to improve the products of the Standard Collection.

Dart



Description

A Mid-hinged, Stainless Steel octagonal lighting column which is designed with simplicity in mind. Raising and lowering the column is a one man see-saw operation which requires no special tools.

Specifications

Columns are available in heights of 5 and 6 metres and are equipped with a unique triple-locking device to prevent accidental lowering of the column.

Stainless Steel is high strength, lightweight, and 100% recyclable. Stainless Steel lighting column have been in service for over 30 years with an unequalled track record with regards to corrosion, and offer excellent value when assessing whole life cost. Full material specification can be found on page 26.

Valmont Stainton operates a Quality Assurance system which complies with requirements of BS EN ISO 9001.

Our welders and welding procedures are independently certified in accordance with EN ISO 9606 and EN ISO 15607.

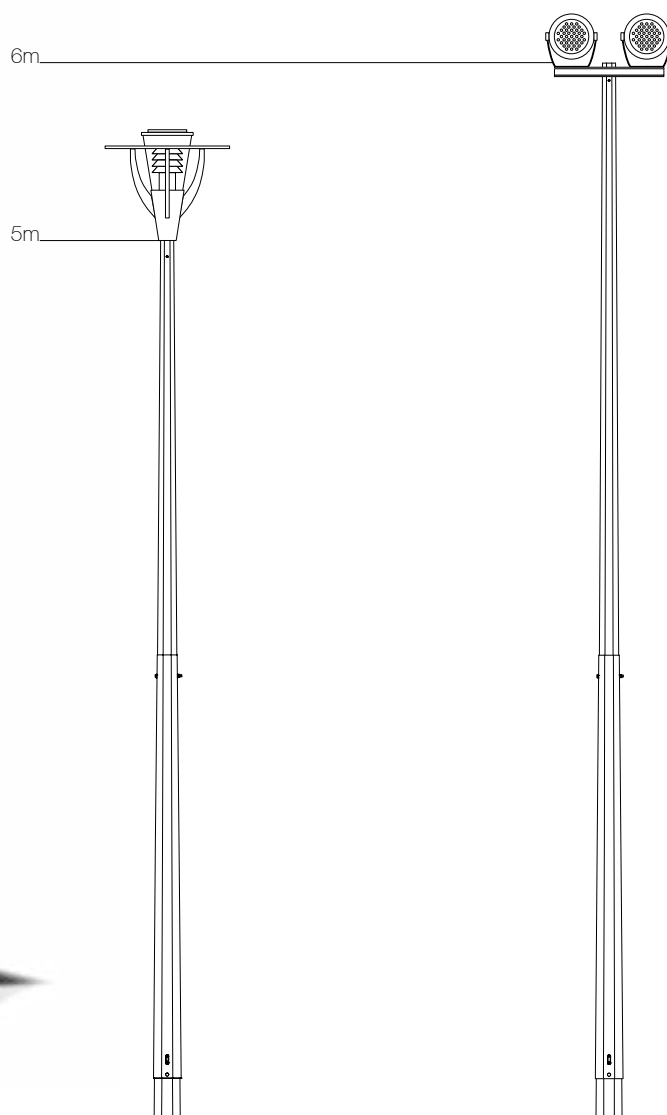

Dimensional Information

Planted Root Option

| Height (m) | BD (mm) | TD (mm) | PD (mm) | DH x DW (mm) | Mass (kg) | OTM (kNm) | Shear (kN) | Min. Concrete Dia. (mm) |
|------------|---------|---------|---------|--------------|-----------|-----------|------------|-------------------------|
| 5 | 164 | 76 | 800 | 500 x 100 | 48 | 5,83 | 1,85 | 689 |
| 6 | 164 | 76 | 1000 | 500 x 100 | 55 | 5,90 | 1,89 | 358 |

Flange Plated Option

| Height (m) | BD (mm) | TD (mm) | DH x DW (mm) | SL x T x BC (mm) | Anchor Bolts | Mass (kg) | OTM (kNm) | Shear (kN) | Concrete Foundation Sizes (mm) |
|------------|---------|---------|--------------|------------------|--------------|-----------|-----------|------------|--------------------------------|
| 5 | 150 | 76 | 500 x 100 | 260 x 15 x 200 | M18 x 400 | 52 | 4,95 | 1,66 | 0,4 sq x 0,7 h |
| 6 | 150 | 76 | 500 x 100 | 260 x 15 x 200 | M18 x 400 | 59 | 5,79 | 1,86 | 0,4 sq x 0,7 h |

Headload Capacity Information

| Height (m) | Mounting Arrangement | Projection (m) | Weight (kg) | Extra Light (m ²) | Light (m ²) | Medium (m ²) | Heavy (m ²) | Extra Heavy (m ²) |
|------------|----------------------|----------------|-------------|-------------------------------|-------------------------|--------------------------|-------------------------|-------------------------------|
| 5 | Post Top | N/A | 15 | 0,72 | 0,57 | 0,48 | 0,40 | 0,20 |
| 6 | Post Top | N/A | 20 | 0,41 | 0,30 | 0,23 | 0,16 | 0,01 |

Dimensions and technical information given as an indication.

See diagrams beginning on page 308 for info regarding the moments and abbreviations used in above tables.

Valmont reserves the right to make, without delay and without prior notice, the technical or aesthetic modifications that it deems necessary to improve the products of the Standard Collection.

ROTA



Description

A base-hinged, tubular lighting column with a spring loaded dampening device.

The Rota raising and lowering system comprises a spring-load dampening device, which enables the raising and lowering of the column in a controlled manner, resulting in access to the light at ground level, within seconds. The device also houses the key to access the door and to remove the Rei-lux anti-vandal screw which allows the lowering of the column, safeguarding unauthorised lowering of the product.

Specifications

Column heights range from 4 to 6 metres and can be used for post top applications or supplied with demountable bracket arm arrangements.

The standard corrosion protection system is hot dip galvanised to BS EN 1461. In addition, a variety of root treatments and full paint specification options are available.

Valmont Stainton operates a Quality Assurance system which complies with requirements of BS EN ISO 9001.

Our welders and welding procedures are independently certified in accordance with EN ISO 9606 and EN ISO 15607.

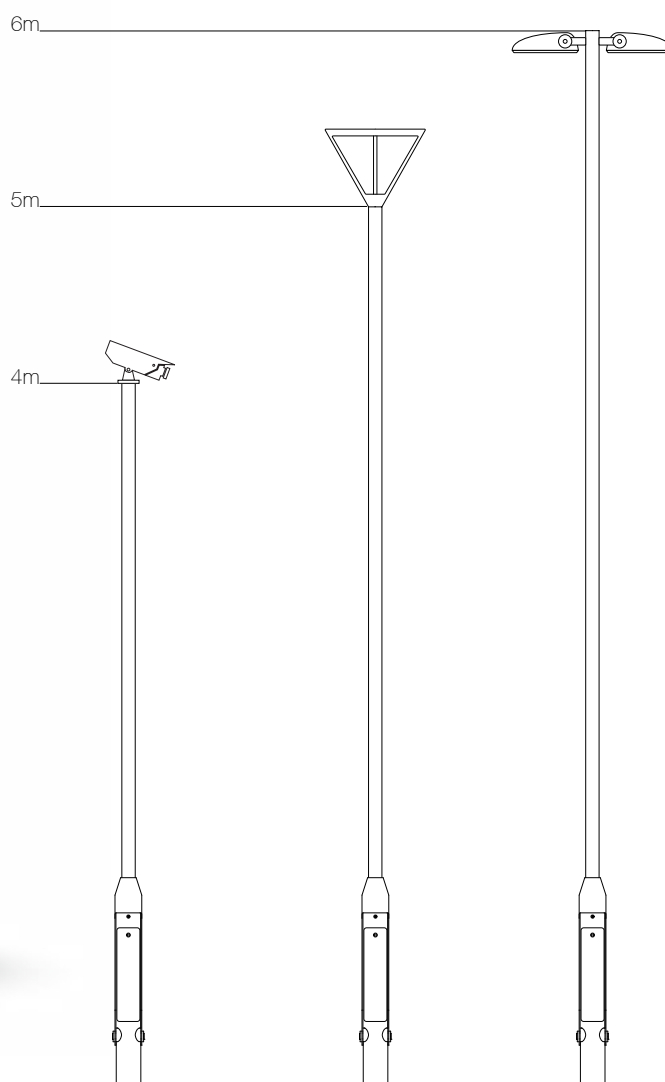

Dimensional Information

Planted Root Option

| Height (m) | BD (mm) | SD K (mm) | SD (mm) | PD (mm) | BH (mm) | SH (mm) | DH x DW (mm) | Mass (kg) | OTM (kNm) | Shear (kN) | Min. Concrete Dia. (mm) |
|------------|---------|-----------|---------|---------|---------|---------|--------------|-----------|-----------|------------|-------------------------|
| 4 | 139,7 | 152 | 76,1 | 800 | 1200 | 2800 | 500 x 100 | 45 | 3,8 | 1,17 | 1057 |
| 5 | 139,7 | 152 | 76,1 | 800 | 1200 | 3800 | 500 x 100 | 50 | 3,6 | 1,01 | 425 |
| 6 | 139,7 | 152 | 76,1 | 1000 | 1200 | 4800 | 500 x 100 | 55 | 3,5 | 0,95 | 213 |

Flange Plated Option

| Height (m) | BD (mm) | SD K (mm) | SD (mm) | BH (mm) | SH (mm) | DH x DW (mm) | SL x T x BC (mm) | Anchor Bolts | Mass (kg) | OTM (kNm) | Shear (kN) | Concrete Foundation Sizes (mm) |
|------------|---------|-----------|---------|---------|---------|--------------|------------------|--------------|-----------|-----------|------------|--------------------------------|
| 4 | 139,7 | 152 | 76,1 | 1000 | 2900 | 500 x 100 | 260 x 15 x 200 | M18 x 400 | 45 | 3,8 | 1,17 | 400 sq x 600 h |
| 5 | 139,7 | 152 | 76,1 | 1000 | 3900 | 500 x 100 | 260 x 15 x 200 | M18 x 400 | 50 | 3,6 | 1,01 | 400 sq x 600 h |
| 6 | 139,7 | 152 | 76,1 | 1000 | 4900 | 500 x 100 | 260 x 15 x 200 | M18 x 400 | 55 | 3,5 | 0,95 | 400 sq x 600 h |

Headload Capacity Information

| Height (m) | Mounting Arrangement | Weight (kg) | Extra Light (m ²) | Light (m ²) | Medium (m ²) | Heavy (m ²) | Extra Heavy (m ²) |
|------------|----------------------|-------------|-------------------------------|-------------------------|--------------------------|-------------------------|-------------------------------|
| 4 | Post Top | 5 | 1,13 | 0,98 | 0,89 | 0,82 | 0,64 |
| | | 10 | 1,10 | 0,95 | 0,86 | 0,79 | 0,62 |
| | | 15 | 1,07 | 0,92 | 0,84 | 0,77 | 0,60 |
| | | 20 | 1,04 | 0,90 | 0,80 | 0,72 | 0,56 |
| | | 30 | 1,00 | 0,87 | 0,8 | 0,72 | 0,56 |
| | | 40 | 0,97 | 0,84 | 0,77 | 0,70 | 0,54 |
| 5 | Post Top | 5 | 0,66 | 0,56 | 0,50 | 0,44 | 0,34 |
| | | 10 | 0,62 | 0,53 | 0,47 | 0,42 | 0,32 |
| | | 15 | 0,60 | 0,51 | 0,46 | 0,41 | 0,31 |
| | | 20 | 0,58 | 0,49 | 0,44 | 0,40 | 0,30 |
| | | 30 | 0,55 | 0,46 | 0,41 | 0,38 | 0,28 |
| | | 40 | 0,52 | 0,44 | 0,40 | 0,36 | 0,26 |
| 6 | Post Top | 5 | 0,38 | 0,31 | 0,27 | 0,23 | 0,16 |
| | | 10 | 0,35 | 0,29 | 0,25 | 0,21 | 0,14 |
| | | 15 | 0,33 | 0,27 | 0,23 | 0,20 | 0,13 |
| | | 20 | 0,32 | 0,26 | 0,22 | 0,19 | 0,12 |
| | | 30 | 0,29 | 0,23 | 0,20 | 0,17 | 0,10 |
| | | 40 | 0,27 | 0,21 | 0,18 | 0,15 | 0,09 |

ROTA Spring Selection Table

| Height (m) | White Spring (Light) | Red Spring (Medium) | Blue Spring (Heavy) |
|------------|----------------------|---------------------|---------------------|
| 4 | 9 kg - 19 kg | 19 kg - 29 kg | 29 kg - 40 kg |
| 5 | 4 kg - 14 kg | 14 kg - 25 kg | 28 kg - 40 kg |
| 6 | 0 kg - 9 kg | 9 kg - 16 kg | 16 kg - 28 kg |



Dimensions and technical information given as an indication.

See diagrams beginning on page 308 for info regarding the moments and abbreviations used in above tables.

Valmont reserves the right to make, without delay and without prior notice, the technical or aesthetic modifications that it deems necessary to improve the products of the Standard Collection.

Tyne

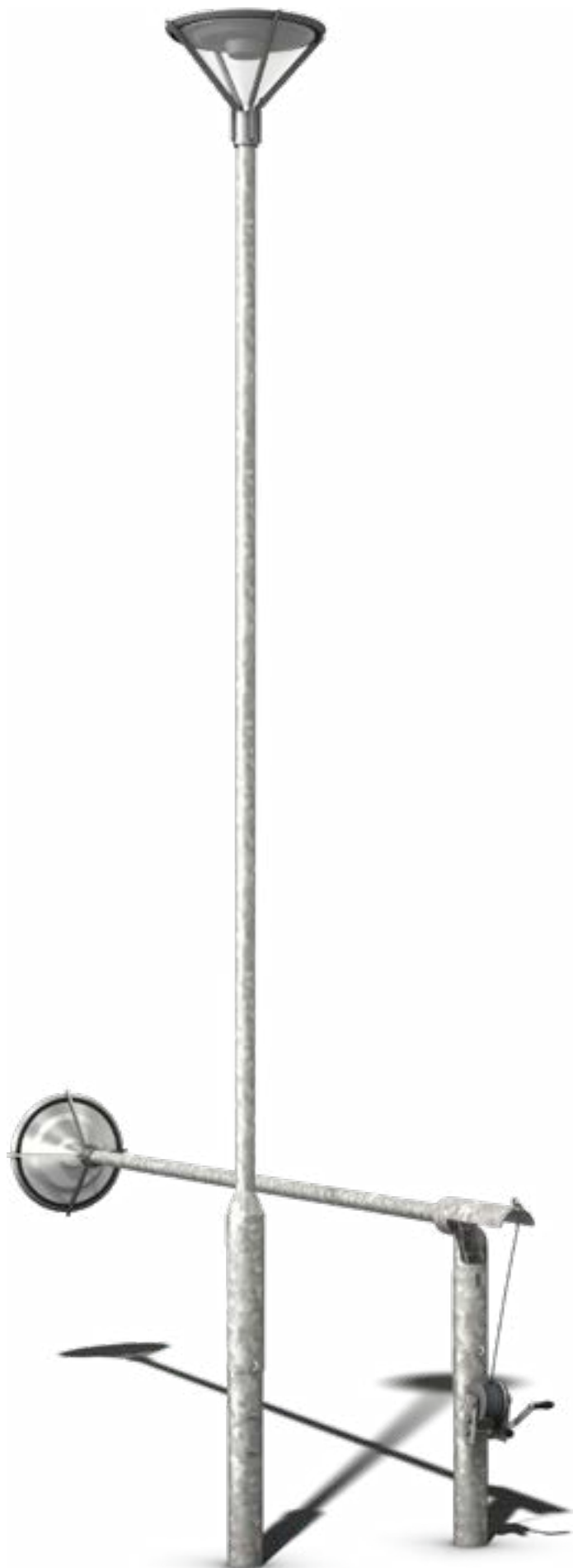

Description

A base-hinged, tubular lighting column which hinges close to ground level and operates by means of a demountable winch system.

Specifications

Column heights range from 8 to 10 metres.

The Tyne can be used for post top applications or supplied with demountable bracket arm arrangements.

The columns are equipped with a unique triple-locking device to prevent accidental lowering of the column.

The standard corrosion protection system is hot dip galvanised to BS EN 1461. In addition, a variety of root treatments and full paint specification options are available.

Valmont Stainton operates a Quality Assurance system which complies with requirements of BS EN ISO 9001.

Our welders and welding procedures are independently certified in accordance with EN ISO 9606 and EN ISO 15607.

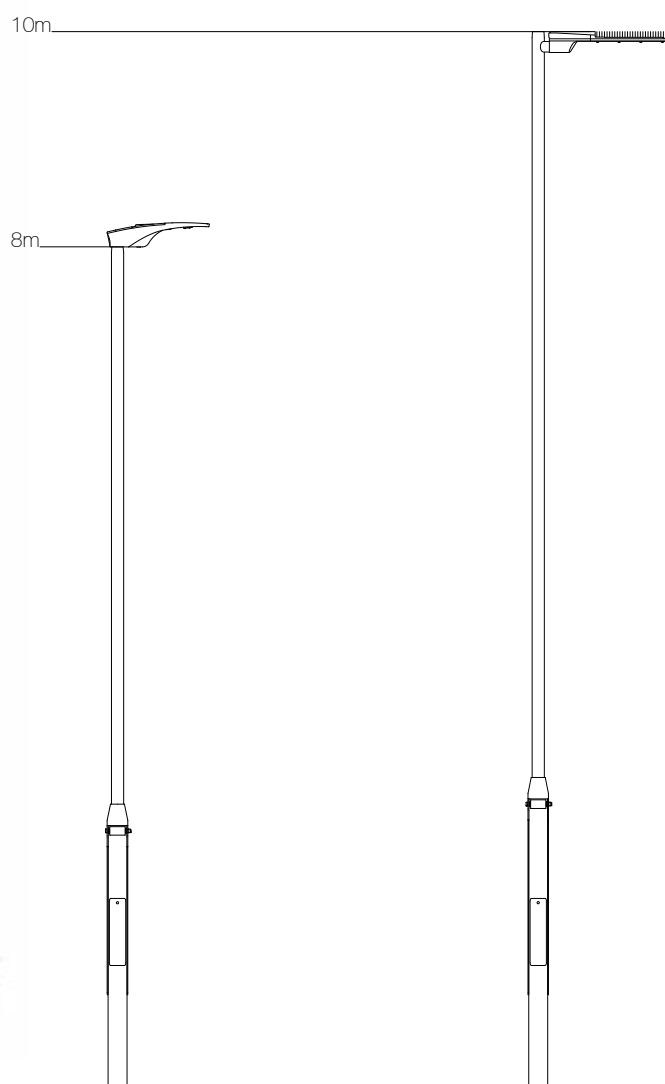

Dimensional Information

Planted Root Option

| Height (m) | BD (mm) | SK D (mm) | SD (mm) | PD (mm) | BH (mm) | SH (mm) | DH x DW (mm) | Mass (kg) | OTM (kNm) | Shear (kN) | Min. Concrete Dia. (mm) |
|------------|---------|-----------|---------|---------|---------|---------|--------------|-----------|-----------|------------|-------------------------|
| 8 | 168,3 | 193,7 | 114,3 | 1200 | 2500 | 5180 | 600 x 115 | 162 | 20,77 | 3,16 | 723 |
| 10 | 168,3 | 193,7 | 139,7 | 1500 | 2850 | 6850 | 600 x 115 | 190 | 20,33 | 2,83 | 362 |

Flange Plated Option

| Height (m) | BD (mm) | SK D (mm) | SD (mm) | BH (mm) | SH (mm) | DH x DW (mm) | SL x T x BC (mm) | Anchor Bolts | Mass (kg) | OTM (kNm) | Shear (kN) | Concrete Foundation Sizes (mm) |
|------------|---------|-----------|---------|---------|---------|--------------|------------------|--------------|-----------|-----------|------------|--------------------------------|
| 8 | 168,3 | 193,7 | 114,3 | 2500 | 5180 | 600 x 115 | 420 x 20 x 300 | M24 x 820 | 164 | 20,59 | 3,19 | 600 sq x 1200 h |
| 10 | 168,3 | 193,7 | 139,7 | 2850 | 6850 | 600 x 115 | 420 x 20 x 300 | M24 x 820 | 186 | 20,35 | 2,88 | 600 sq x 1500 h |

Headload Capacity Information

| Height (m) | Mounting Arrangement | Projection (m) | Weight (kg) | Extra Light (m ²) | Light (m ²) | Medium (m ²) | Heavy (m ²) | Extra Heavy (m ²) |
|------------|----------------------|----------------|-------------|-------------------------------|-------------------------|--------------------------|-------------------------|-------------------------------|
| 8 | Post Top | N/A | 60 | 1,79 | 1,57 | 1,43 | 1,30 | 1,04 |
| | Single Arm | 0,5 | 40 | 0,97 | 0,83 | 0,76 | 0,69 | 0,54 |
| | Double Arm | 0,5 | 20 | 0,72 | 0,62 | 0,57 | 0,51 | 0,41 |
| | Single Arm | 1 | 20 | 0,80 | 0,69 | 0,62 | 0,56 | 0,43 |
| | Double Arm | 1 | 20 | 0,67 | 0,57 | 0,52 | 0,46 | 0,36 |
| 10 | Post Top | N/A | 60 | 1,06 | 0,92 | 0,85 | 0,79 | 0,59 |
| | Single Arm | 0,5 | 40 | 0,61 | 0,52 | 0,48 | 0,44 | 0,32 |
| | Double Arm | 0,5 | 40 | 0,42 | 0,37 | 0,34 | 0,31 | 0,21 |
| | Single Arm | 1 | 20 | 0,51 | 0,44 | 0,41 | 0,37 | 0,26 |
| | Double Arm | 1 | 20 | 0,39 | 0,33 | 0,29 | 0,26 | 0,17 |

Dimensions and technical information given as an indication.

See diagrams beginning on page 308 for info regarding the moments and abbreviations used in above tables.

Valmont reserves the right to make, without delay and without prior notice, the technical or aesthetic modifications that it deems necessary to improve the products of the Standard Collection.

Humber



Description

A base hinged octagonal lighting column which is operated via a hydraulic cylinder which makes lantern maintenance safe and easy.

Specifications

Column heights range from 10 to 20 metres covering a vast array of headweights.

Humber columns are suitable for varying cross arm brackets and are ideally suited for sports lighting and restricted access applications.

The standard corrosion protection system is hot dip galvanised to BS EN 1461. In addition, a variety of root treatments and full paint specification options are available.

Valmont Stainton operates a Quality Assurance system which complies with requirements of BS EN ISO 9001.

Our welders and welding procedures are independently certified in accordance with EN ISO 9606 and EN ISO 15607.

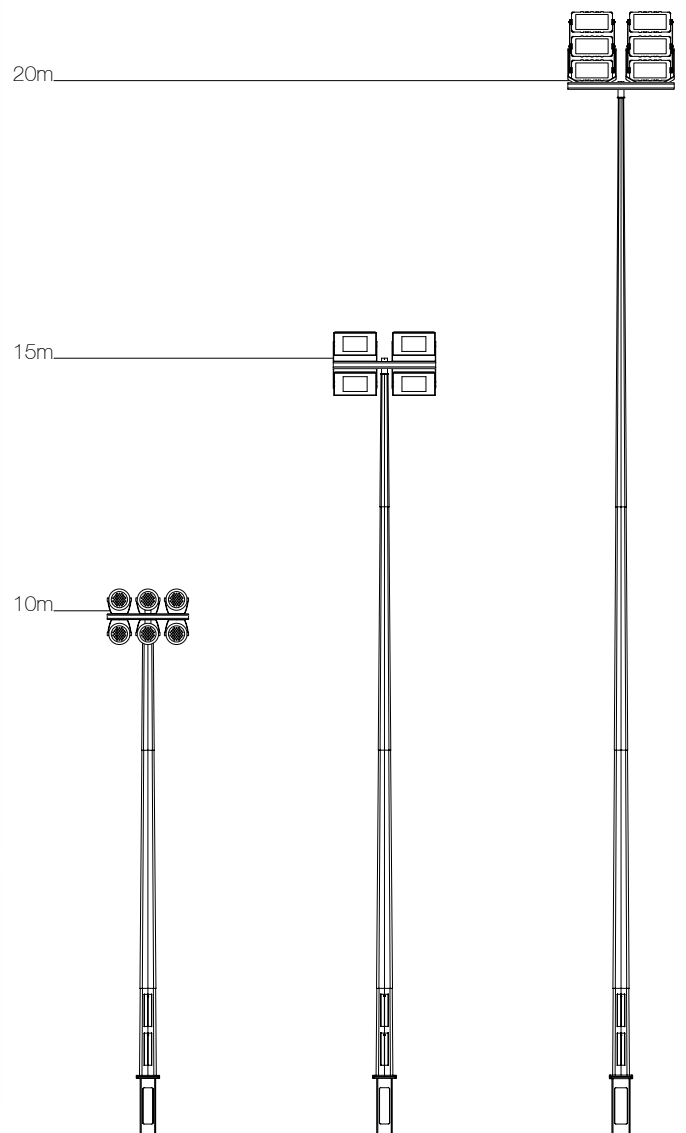

Dimensional Information

Light Duty Flange Plated Option

| Height (m) | A/F Top (mm) | WB (mm) | SL x T x BC (mm) | Anchor Bolts | Mass (kg) | OTM (kNm) | Shear (kN) | Concrete Foundation Sizes (mm) |
|------------|--------------|---------|------------------|--------------|-----------|-----------|------------|--------------------------------|
| 10 | 191 | 300 | 550 x 30 x 400 | M30 x 1090 | 399 | 127,8 | 16,00 | 2100 sq x 1300 h |
| 12 | 161 | 300 | 550 x 30 x 400 | M30 x 1090 | 427 | 126,4 | 13,45 | 2000 sq x 1400 h |
| 15 | 125 | 300 | 550 x 30 x 400 | M30 x 1090 | 468 | 122,3 | 14,25 | 2100 sq x 1200 h |
| 18 | 148 | 350 | 650 x 45 x 480 | M39 x 1380 | 782 | 213,4 | 20,20 | 2500 sq x 1400 h |

* A/F Top = Dimension across flat surfaces of octagonal profile

* WB = Width of SHS box section at base of column

Heavy Duty Flange Plated Option

| Height (m) | A/F Top (mm) | WB (mm) | SL x T x BC (mm) | Anchor Bolts | Mass (kg) | OTM (kNm) | Shear (kN) | Concrete Foundation Sizes (mm) |
|------------|--------------|---------|------------------|--------------|-----------|-----------|------------|--------------------------------|
| 12 | 160 | 300 | 550 x 35 x 420 | M36 x 1400 | 539 | 147,2 | 17,20 | 2100 sq x 1500 h |
| 15 | 125 | 300 | 550 x 35 x 420 | M36 x 1400 | 627 | 157,5 | 14,02 | 2200 sq x 1400 h |
| 18 | 155 | 350 | 650 x 45 x 480 | M39 x 1380 | 887 | 241,1 | 20,60 | 2500 sq x 1600 h |
| 20 | 127 | 350 | 650 x 45 x 480 | M39 x 1380 | 917 | 240,3 | 19,45 | 2500 sq x 1600 h |

* A/F Top = Dimension across flat surfaces of octagonal profile

* WB = Width of SHS box section at base of column

Headload Capacity Information

Light Duty Option

| Height (m) | Weight (kg) | Extra Light (m ²) | Light (m ²) | Medium (m ²) | Heavy (m ²) | Extra Heavy (m ²) |
|------------|-------------|-------------------------------|-------------------------|--------------------------|-------------------------|-------------------------------|
| 10 | 100 | 9,98 | 8,92 | 8,16 | 7,40 | 5,76 |
| | 200 | 9,68 | 8,39 | 7,67 | 6,95 | 5,39 |
| | 300 | 9,25 | 8,02 | 7,32 | 6,64 | 5,13 |
| 12 | 100 | 7,20 | 6,21 | 5,62 | 5,05 | 3,82 |
| | 200 | 6,66 | 5,72 | 5,17 | 4,64 | 3,49 |
| | 300 | 6,28 | 5,39 | 4,86 | 4,37 | 3,28 |
| 15 | 100 | 3,32 | 2,85 | 2,57 | 2,32 | 1,75 |
| | 200 | 2,94 | 2,53 | 2,28 | 2,05 | 1,54 |
| | 300 | 2,69 | 2,30 | 2,07 | 1,85 | 1,38 |
| 18 | 100 | 4,70 | 4,08 | 3,73 | 3,37 | 2,55 |
| | 200 | 4,27 | 3,69 | 3,37 | 3,04 | 2,28 |
| | 300 | 3,94 | 3,41 | 3,10 | 2,81 | 2,07 |

Heavy Duty Option

| Height (m) | Weight (kg) | Extra Light (m ²) | Light (m ²) | Medium (m ²) | Heavy (m ²) | Extra Heavy (m ²) |
|------------|-------------|-------------------------------|-------------------------|--------------------------|-------------------------|-------------------------------|
| 12 | 100 | 7,85 | 6,87 | 6,32 | 5,78 | 4,60 |
| | 200 | 7,34 | 6,40 | 5,89 | 5,39 | 4,29 |
| | 300 | 6,95 | 6,09 | 5,58 | 5,11 | 4,06 |
| 15 | 100 | 6,09 | 5,23 | 4,68 | 4,21 | 3,12 |
| | 200 | 5,58 | 4,76 | 4,25 | 3,82 | 2,81 |
| | 300 | 5,19 | 4,41 | 3,98 | 3,55 | 2,57 |
| 18 | 100 | 7,07 | 6,01 | 5,39 | 4,80 | 3,47 |
| | 200 | 6,48 | 5,50 | 4,92 | 4,37 | 3,12 |
| | 300 | 6,09 | 5,11 | 4,57 | 4,06 | 2,89 |
| 20 | 100 | 4,92 | 4,25 | 3,90 | 3,51 | 2,57 |
| | 200 | 4,45 | 3,86 | 3,51 | 3,16 | 2,22 |
| | 300 | 4,10 | 3,55 | 3,20 | 2,89 | 1,99 |

Dimensions and technical information given as an indication.

See diagrams beginning on page 308 for info regarding the moments and abbreviations used in above tables.

Valmont reserves the right to make, without delay and without prior notice, the technical or aesthetic modifications that it deems necessary to improve the products of the Standard Collection.

Large Mast Applications



Sports Lighting
High Mast Lighting
Malto

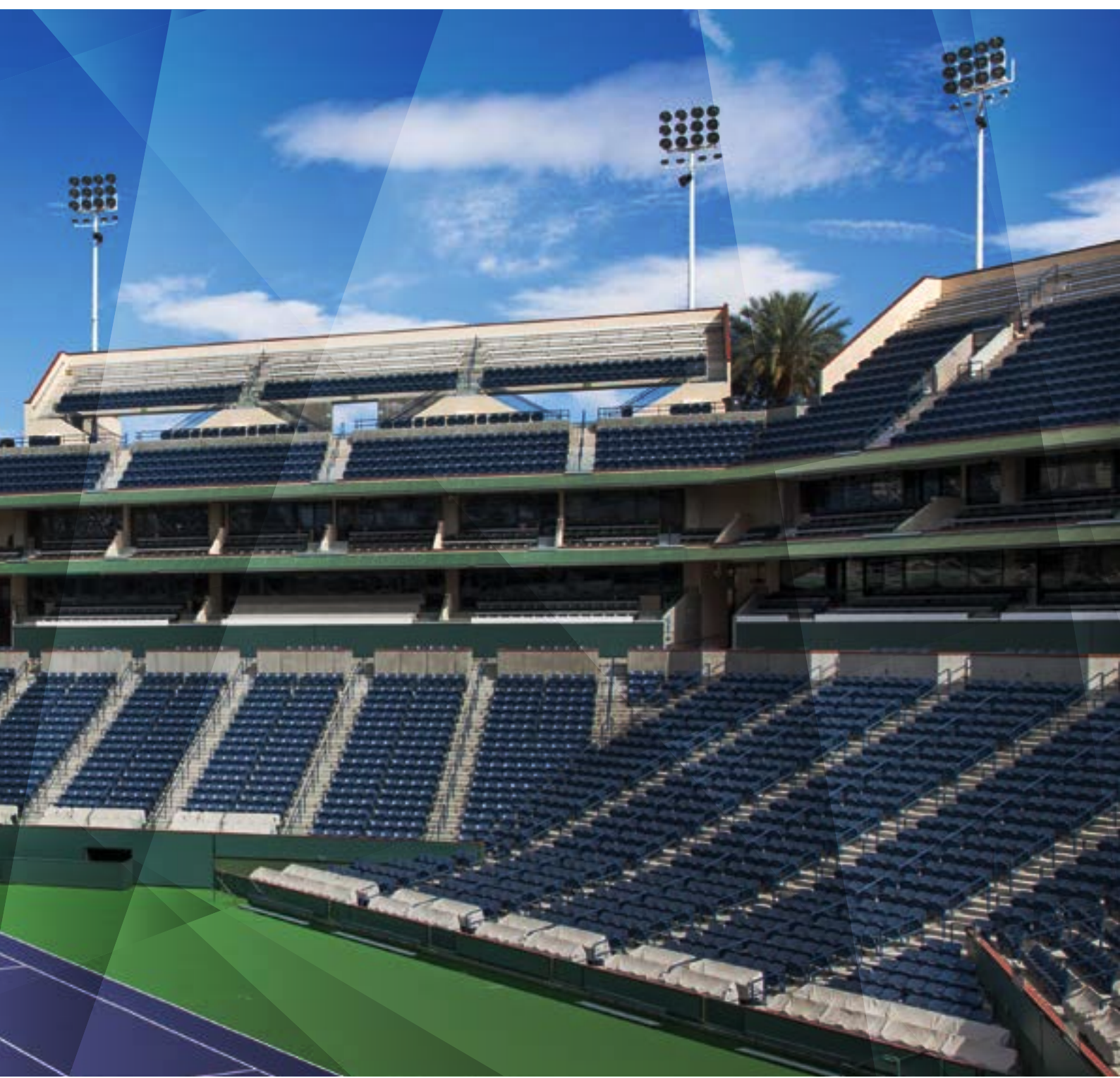

Sports Lighting

Beyond Traditional Sports Lighting...

Modern sporting venues require exceptional lighting for ideal visibility by players and fans alike. Stadiums which host televised events have an even greater illumination requirement to ensure optimal in-home viewing.

Many of the most anticipated televised sporting events in the world are made possible by sports lighting poles which are custom engineered and manufactured by Valmont.



A Solution For Every Project.

With over 25 years of sport floodlighting column manufacturing experience coupled with utilisation of state of the art methods of design and calculation, we have developed the most comprehensive range of sports floodlighting columns currently available in the market.

From 20m to 55m mounting heights, Mid Hinged/ Base Hinged/ Raising and Lowering headframes and static floodlighting configurations suitable for a full cross section of sports including football, rugby, tennis, hockey, skate parks and MUGA pitches



Safe and Easy Maintenance.

Sports lighting columns often exceed heights of 25 metres and in some cases, maintenance can not be accomplished at ground level.

Valmont Stainton offers a wide variety of mounting accessories, including platforms, climbing ladders and retractable lighting systems to ensure the safety of maintenance workers. See page 253 for more information.



High Mast Lighting

Occasionally, Size Does Matter...

High-mast lighting installations are commonly located along Motorways and principle routes everywhere, especially useful where differing road levels are a consideration.

Valmont's tapered steel high-mast poles also support other large-area lighting applications, such as airports, car parks, shipping terminal facilities and large heavy-industry zones. In all these applications, safety is paramount and technical design expertise is essential.



Knowledge That You Can Trust.

With deep engineering know-how, Valmont is well qualified to account for the lighting load, tower weight, variable wind speeds, local soil conditions and a host of other relevant variables which less experienced suppliers may not consider in their designs.

No matter where your project takes you around the world, Valmont is standing by and ready to assist.



Certified and Reliable.

Valmont high masts meet CE requirements and a variety of designs and mounting accessories are available, include platforms, climbing ladders and retractable lighting systems.

Hot-dip galvanising treatment is available to protect the steel from corrosion. A wide selection of colors are available as well to add an attractive and protective exterior coating utilizing wet paint or powder coating technology.

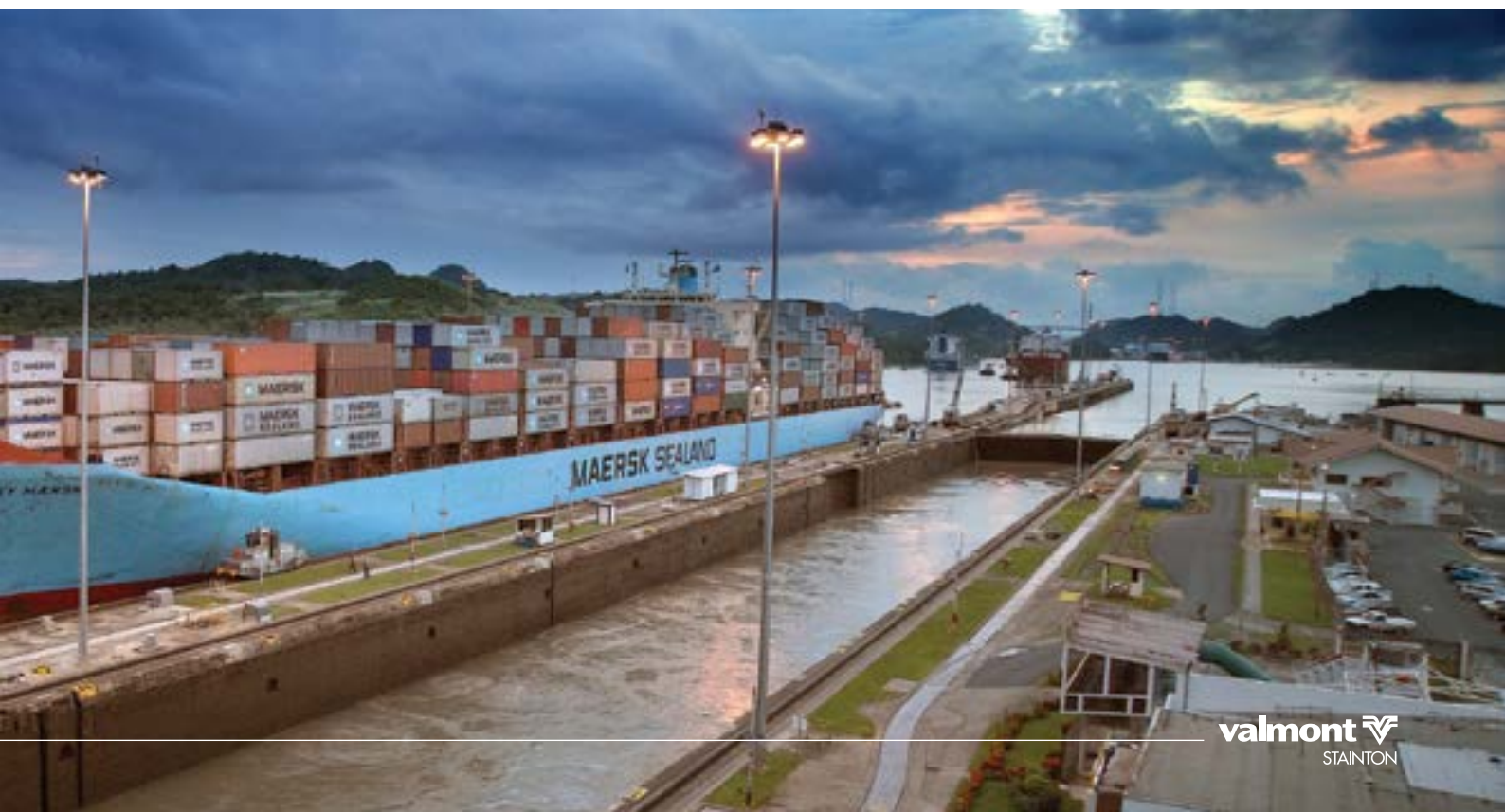

High Mast Standard Duty



Description

High-mast lighting installations are commonly located where today's busy motorways merge or intersect. Valmont's tapered steel high-mast poles also support other large-area lighting applications, such as airports, car parks, shipping terminal facilities and large heavy-industry zones. In all these applications, safety is paramount and technical design expertise is essential.

Specifications

Standard duty high masts are available in mounting heights from 20 to 30 metres.

They can be used for fixed X-arm floodlighting or with a raising and lowering headframe arrangement.

Valmont Stainton operates a Quality Assurance system which complies with requirements of BS EN ISO 9001.

Our welders and welding procedures are independently certified in accordance with EN ISO 9606 and EN ISO 15607.

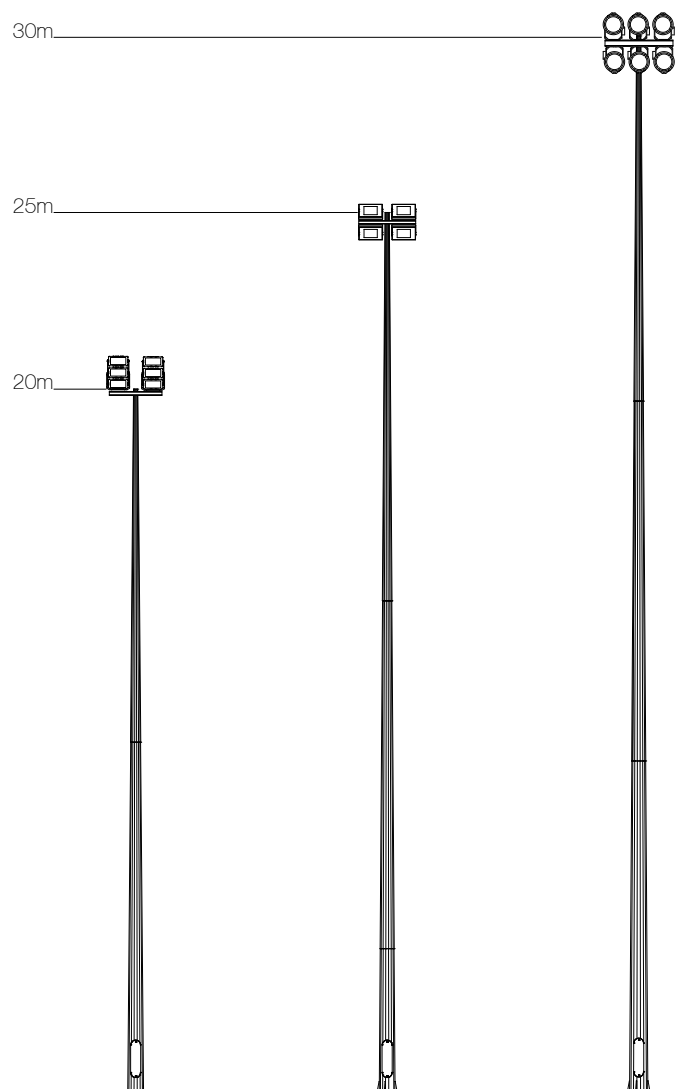

Dimensional Information

Flange Plated Option

| Height (m) | BD (mm) | TD (mm) | DH x DW (mm) | OD x T x BC (mm) | Anchor Bolts | Mass (kg) | OTM (kNm) | Shear (kN) | Concrete Foundation Size (mm) |
|------------|---------|---------|--------------|------------------|--------------|-----------|-----------|------------|-------------------------------|
| 20 | 435 | 117 | 1040 x 245 | 630 x 35 x 540 | M24 x 800 | 585 | 157,23 | 12,83 | 2200 sq x 1400 h |
| 25 | 433 | 115 | 1040 x 245 | 650 x 40 x 550 | M24 x 800 | 825 | 175,40 | 13,96 | 2300 sq x 1400 h |
| 30 | 501 | 116 | 1040 x 245 | 720 x 45 x 610 | M24 x 800 | 1146 | 288,14 | 18,26 | 2700 sq x 1500 h |

Headload Capacity Information

| Height (m) | Mounting Config. | Weight (kg) | Coastal Location | | | | | | Inland Location | | | | | |
|------------|------------------|-------------|--------------------------|--------------------------|--------------------------|--------------------------|--------------------------|--------------------------|--------------------------|--------------------------|--------------------------|--------------------------|--------------------------|--------------------------|
| | | | 22 mps (m ²) | 23 mps (m ²) | 24 mps (m ²) | 25 mps (m ²) | 26 mps (m ²) | 27 mps (m ²) | 22 mps (m ²) | 23 mps (m ²) | 24 mps (m ²) | 25 mps (m ²) | 26 mps (m ²) | 27 mps (m ²) |
| 20 | Post Top | 150 | 3,388 | 3,021 | 2,702 | 2,368 | 2,056 | 1,779 | 2,716 | 2,399 | 2,065 | 1,772 | 1,512 | 1,281 |
| | | 250 | 3,126 | 2,781 | 2,481 | 2,157 | 1,862 | 1,601 | 2,498 | 2,192 | 1,876 | 1,598 | 1,353 | 1,135 |
| | | 350 | 2,917 | 2,591 | 2,308 | 1,998 | 1,717 | 1,468 | 2,325 | 2,035 | 1,733 | 1,468 | 1,234 | 1,026 |
| 25 | Post Top | 150 | 2,243 | 1,866 | 1,537 | 1,248 | 0,992 | 0,757 | 1,570 | 1,261 | 0,991 | 0,750 | 0,532 | 0,338 |
| | | 250 | 1,995 | 1,641 | 1,333 | 1,063 | 0,821 | 0,601 | 1,369 | 1,080 | 0,828 | 0,600 | 0,396 | 0,214 |
| | | 350 | 1,804 | 1,470 | 1,179 | 0,924 | 0,694 | 0,486 | 1,217 | 0,943 | 0,705 | 0,488 | 0,295 | 0,123 |
| 30 | Post Top | 150 | 2,245 | 1,976 | 1,744 | 1,540 | 1,361 | 1,073 | 1,698 | 1,483 | 1,296 | 1,023 | 0,719 | 0,449 |
| | | 250 | 1,993 | 1,746 | 1,532 | 1,346 | 1,180 | 0,869 | 1,493 | 1,296 | 1,124 | 0,828 | 0,543 | 0,289 |
| | | 350 | 1,784 | 1,556 | 1,358 | 1,185 | 1,011 | 0,717 | 1,322 | 1,140 | 0,981 | 0,681 | 0,412 | 0,172 |

Dimensions and technical information given as an indication.

See diagrams beginning on page 308 for info regarding the moments and abbreviations used in above tables.

Valmont reserves the right to make, without delay and without prior notice, the technical or aesthetic modifications that it deems necessary to improve the products of the Standard Collection.

High Mast Heavy Duty

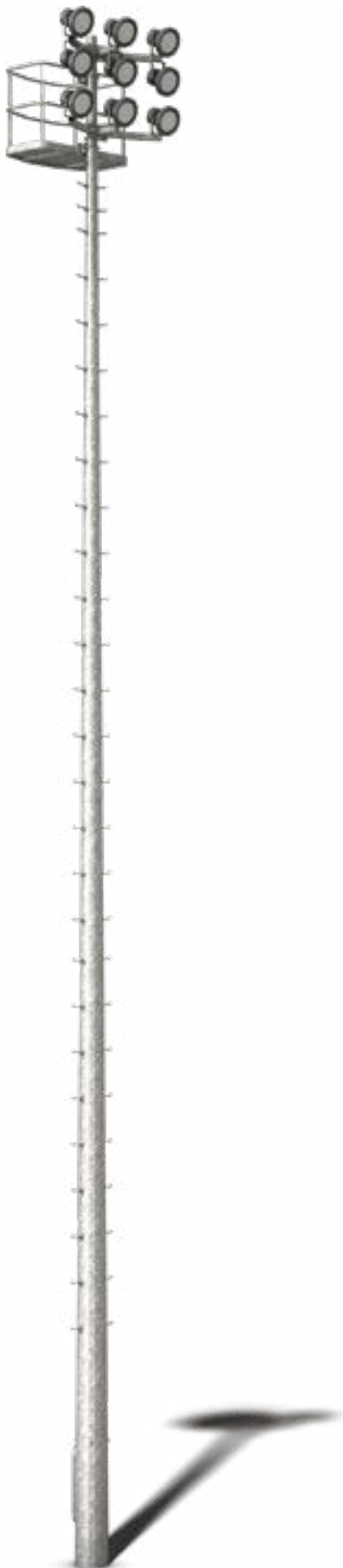

Description

High-mast lighting installations are commonly located where today's busy motorways merge or intersect. Valmont's tapered steel high-mast poles also support other large-area lighting applications, such as airports, car parks, shipping terminal facilities and large heavy-industry zones. In all these applications, safety is paramount and technical design expertise is essential.

Specifications

Heavy duty high masts are available in mounting heights from 15 to 30 metres.

They can be used for fixed X-arm floodlighting or with a raising and lowering headframe arrangement. Our heavy duty columns are also available with climbing access options including climbing rungs and working platforms.

Valmont Stainton operates a Quality Assurance system which complies with requirements of BS EN ISO 9001.

Our welders and welding procedures are independently certified in accordance with EN ISO 9606 and EN ISO 15607.

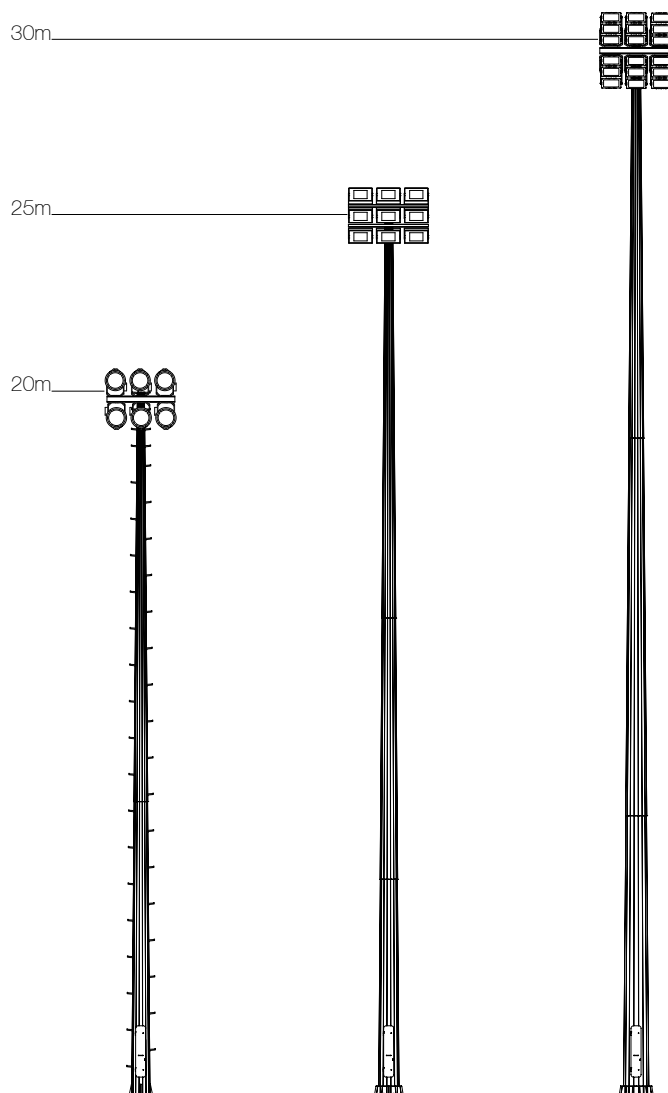

Dimensional Information

Flange Plated Option

| Height (m) | BD (mm) | TD (mm) | DH x DW (mm) | OD x T x BC (mm) | Anchor Bolts | Mass (kg) | OTM (kNm) | Shear (kN) | Concrete Foundation Size (mm) |
|------------|---------|---------|--------------|------------------|--------------|-----------|-----------|------------|-------------------------------|
| 15 | 465 | 140 | 1400 x 250 | 670 x 35 x 570 | M24 x 820 | 543 | 174,52 | 15,45 | 2300 sq x 1400 h |
| 20 | 520 | 200 | 1400 x 250 | 730 x 45 x 630 | M24 x 820 | 954,5 | 297,93 | 21,49 | 2700 sq x 1600 h |
| 25 | 580 | 214 | 1400 x 250 | 860 x 30 x 770 | M24 x 820 | 1506 | 444,10 | 28,01 | 3100 sq x 1700 h |
| 30 | 720 | 230 | 1400 x 250 | 990 x 30 x 900 | M24 x 800 | 2175 | 692,73 | 38,42 | 3500 sq x 2000 h |

Headload Capacity Information

| Height (m) | Mounting Config. | Weight (kg) | Coastal Location | | | | | | Inland Location | | | | | |
|------------|------------------|-------------|--------------------------|--------------------------|--------------------------|--------------------------|--------------------------|--------------------------|--------------------------|--------------------------|--------------------------|--------------------------|--------------------------|--------------------------|
| | | | 22 mps (m ²) | 23 mps (m ²) | 24 mps (m ²) | 25 mps (m ²) | 26 mps (m ²) | 27 mps (m ²) | 22 mps (m ²) | 23 mps (m ²) | 24 mps (m ²) | 25 mps (m ²) | 26 mps (m ²) | 27 mps (m ²) |
| 15 | Post Top | 100 | 7,67 | 6,88 | 6,18 | 5,57 | 5,03 | 4,55 | 5,69 | 5,08 | 4,54 | 4,07 | 3,65 | 3,28 |
| | | 200 | 7,29 | 6,52 | 5,85 | 5,26 | 4,75 | 4,29 | 5,39 | 4,80 | 4,29 | 3,83 | 3,43 | 3,07 |
| | | 300 | 7,00 | 6,26 | 5,61 | 5,04 | 4,54 | 4,09 | 5,18 | 4,60 | 4,10 | 3,66 | 3,27 | 2,92 |
| | | 400 | 6,77 | 6,05 | 5,42 | 4,86 | 4,37 | 3,93 | 5,00 | 4,43 | 3,94 | 3,52 | 3,14 | 2,80 |
| | | 500 | 6,58 | 5,87 | 5,25 | 4,72 | 4,24 | 3,81 | 4,84 | 4,30 | 3,83 | 3,41 | 3,04 | 2,70 |
| 20 | Post Top | 100 | 8,97 | 8,02 | 7,10 | 6,30 | 5,59 | 4,96 | 6,35 | 5,56 | 4,86 | 4,25 | 3,70 | 3,22 |
| | | 200 | 8,55 | 7,61 | 6,73 | 5,96 | 5,27 | 4,66 | 6,02 | 5,24 | 4,58 | 3,98 | 3,46 | 3,00 |
| | | 300 | 8,23 | 7,31 | 6,45 | 5,69 | 5,03 | 4,43 | 5,76 | 5,01 | 4,35 | 3,79 | 3,28 | 2,83 |
| | | 400 | 7,96 | 7,05 | 6,21 | 5,48 | 4,83 | 4,26 | 5,56 | 4,82 | 4,19 | 3,62 | 3,13 | 2,69 |
| | | 500 | 7,73 | 6,84 | 6,02 | 5,30 | 4,67 | 4,10 | 5,37 | 4,66 | 4,03 | 3,48 | 3,01 | 2,58 |
| 25 | Post Top | 100 | 8,78 | 7,86 | 7,05 | 6,35 | 5,73 | 5,08 | 6,23 | 5,55 | 4,88 | 4,18 | 3,57 | 3,03 |
| | | 200 | 8,38 | 7,49 | 6,72 | 6,04 | 5,44 | 4,77 | 5,93 | 5,26 | 4,58 | 3,91 | 3,32 | 2,79 |
| | | 300 | 8,06 | 7,20 | 6,45 | 5,78 | 5,21 | 4,53 | 5,68 | 5,04 | 4,35 | 3,70 | 3,12 | 2,61 |
| | | 400 | 7,79 | 6,95 | 6,22 | 5,58 | 5,00 | 4,34 | 5,48 | 4,85 | 4,17 | 3,52 | 2,97 | 2,47 |
| | | 500 | 7,55 | 6,73 | 6,02 | 5,39 | 4,81 | 4,16 | 5,30 | 4,70 | 4,00 | 3,38 | 2,83 | 2,34 |
| 30 | Post Top | 100 | 10,00 | 9,09 | 8,17 | 7,36 | 6,64 | 5,87 | 7,11 | 6,32 | 5,48 | 4,75 | 4,08 | 3,40 |
| | | 200 | 9,74 | 8,71 | 7,83 | 7,04 | 6,31 | 5,56 | 6,81 | 6,01 | 5,20 | 4,49 | 3,81 | 3,14 |
| | | 300 | 9,41 | 8,41 | 7,54 | 6,78 | 6,05 | 5,31 | 6,56 | 5,76 | 4,97 | 4,28 | 3,58 | 2,94 |
| | | 400 | 9,12 | 8,15 | 7,30 | 6,55 | 5,83 | 5,11 | 6,35 | 5,55 | 4,78 | 4,10 | 3,41 | 2,77 |
| | | 500 | 8,86 | 7,91 | 7,08 | 6,36 | 5,64 | 4,93 | 6,16 | 5,36 | 4,61 | 3,94 | 3,25 | 2,62 |

Dimensions and technical information given as an indication.

See diagrams beginning on page 308 for info regarding the moments and abbreviations used in above tables.

Valmont reserves the right to make, without delay and without prior notice, the technical or aesthetic modifications that it deems necessary to improve the products of the Standard Collection.

Malto Raise and Lower System

The modern raise and lower system...

The Malto Mobile Crown combines the many benefits of a retractable raise and lower system with a stylish and modern aesthetic.

A lowering system greatly improves maintenance safety by allowing work to be completed at ground level, rather than on an elevated lift, platform or crane. Lowering systems can also create considerable cost savings over the life span of the column by eliminating the need for equipment rental for routine equipment maintenance.

The Malto Mobile Crown is ideal for high-mast lighting installations such as airports, shipping ports, industrial zones, and storage warehouses.

Features

Integrated internal drive is installed within the mast and is easily operated by a convenient wireless remote control device (included).

Illumination optimization - install up to 12 floodlights along the crown structure perimeter.

Additional devices, such as surveillance cameras, antennas and glare inhibitors may be mounted.







Project Lead: Alstom | Installation: Nottingham Tram

- Traffic Signals
- Utility Columns
- Tramway Poles
- Telecom Masts
- Smart Columns
- Transportation
- Heritage Products
- Furniture
- Sign Posts



Traffic Signals.

Valmont Stainton can offer the two styles of Overhead Traffic Signal Cantilever Masts in accordance either BS EN 40 or Highways England specification BD9407.

Traffic Signal Cantilever Masts: BS EN 40 Specification

The standard mast in this range has a mounting height of approximately 6.2m, with an outreach of between 4m and 5.5m, and can typically carry two Traffic Signal heads, back-to-back at the end of the cantilever, or evenly distributed along the cantilever. Standard duty applications, requiring standard lighting column size foundations. Bespoke designs are available.

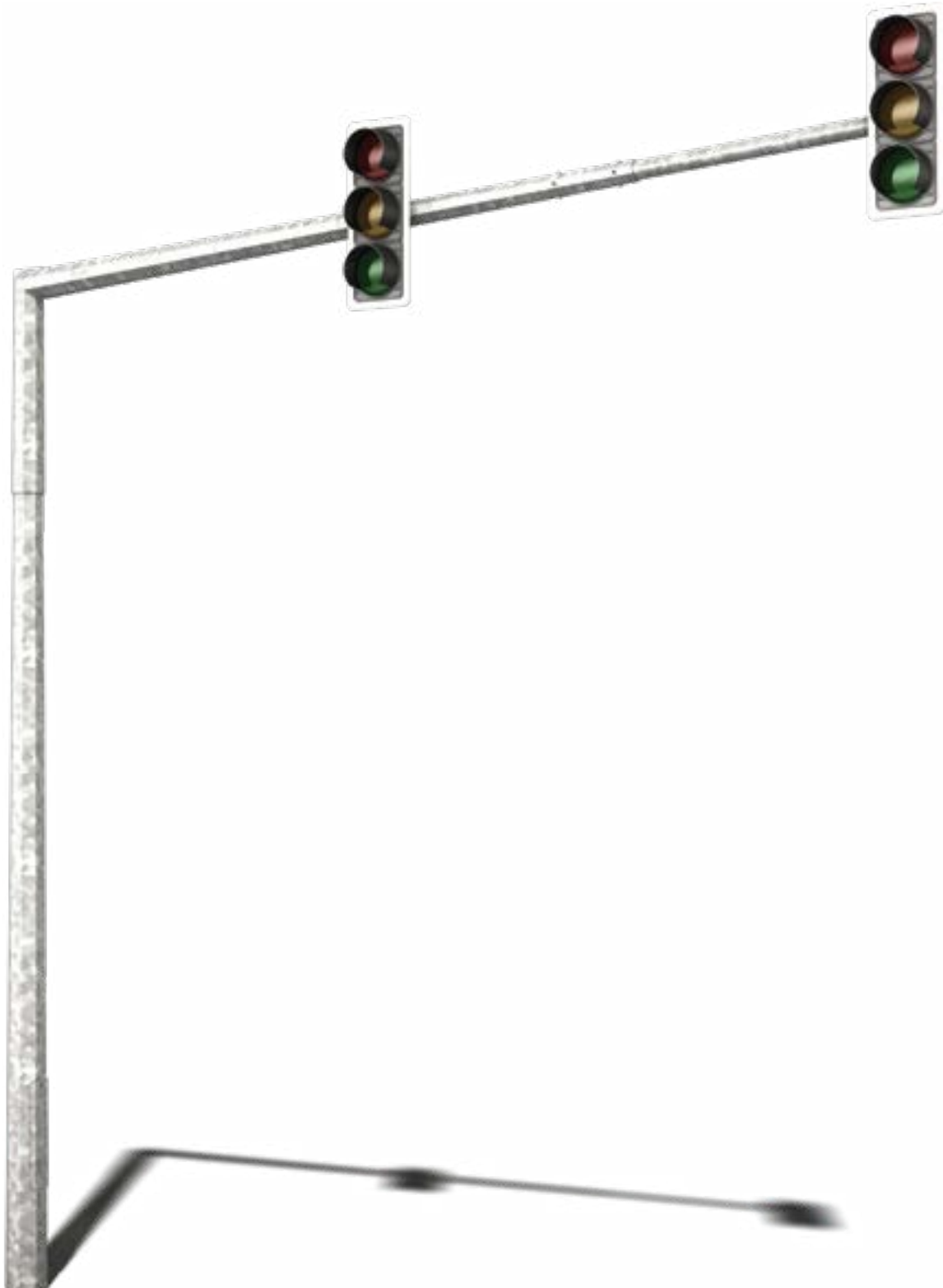

Dimensional Information

Planted Root Option

| Height (m) | Projection (m) | BD (mm) | TD (mm) | PD (mm) | DH x DW (mm) | Mass (kg) | OTM (kNm) | Shear (kN) | Min. Concrete Dia. (mm) |
|------------|----------------|---------|---------|---------|--------------|-----------|-----------|------------|-------------------------|
| 6,2 | 5,5 | 248 | 96 | 1200 | 600 x 115 | 220 | 34,26 | 6,86 | 1225 |

Flange Plated Option

| Height (m) | Projection (m) | BD (mm) | TD (mm) | DH x DW (mm) | SL x T x BC (mm) | Anchor Bolts | Mass (kg) | OTM (kNm) | Shear (kN) | Concrete Foundation Sizes (mm) |
|------------|----------------|---------|---------|--------------|------------------|--------------|-----------|-----------|------------|--------------------------------|
| 6,2 | 5,5 | 231 | 96 | 600 x 115 | 420 x 20 x 300 | M24 x 820 | 218 | 34,26 | 6,86 | 800 sq x 1500 h |

Dimensions and technical information given as an indication.

See diagrams beginning on page 308 for info regarding the moments and abbreviations used in above tables.

Valmont reserves the right to make, without delay and without prior notice, the technical or aesthetic modifications that it deems necessary to improve the products of the Standard Collection.

Headload Capacity Information

BS EN 40 Max Effective Windage Area: Based on T CAT II

| Height (m) | Mounting Arrangement | Projection (m) | Weight (kg) | Extra Light | Light | Medium | Heavy | Extra Heavy |
|------------|----------------------|----------------|-------------|-------------|-------|--------|-------|-------------|
| 6,2 | Single Arm | 5,5 | 20 | 1,29 | 1,08 | 0,96 | 0,85 | 0,59 |
| 6,2 | Single Arm | 5,5 | 30 | 1,23 | 1,04 | 0,91 | 0,80 | 0,55 |
| 6,2 | Single Arm | 5,5 | 40 | 2,00 | 1,72 | 1,53 | 1,34 | 0,93 |
| 6,2 | Single Arm | 5,5 | 60 | 1,94 | 1,60 | 1,43 | 1,24 | 0,85 |

BS EN 40 Max Effective Windage Area: Based on T CAT III

| Height (m) | Mounting Arrangement | Projection (m) | Weight (kg) | Extra Light | Light | Medium | Heavy | Extra Heavy |
|------------|----------------------|----------------|-------------|-------------|-------|--------|-------|-------------|
| 6,2 | Single Arm | 5,5 | 20 | 1,75 | 1,48 | 1,34 | 1,18 | 0,86 |
| 6,2 | Single Arm | 5,5 | 30 | 1,67 | 1,42 | 1,27 | 1,13 | 0,82 |
| 6,2 | Single Arm | 5,5 | 40 | 2,00 | 2,00 | 2,00 | 1,89 | 1,37 |
| 6,2 | Single Arm | 5,5 | 60 | 2,00 | 2,00 | 2,00 | 1,76 | 1,27 |

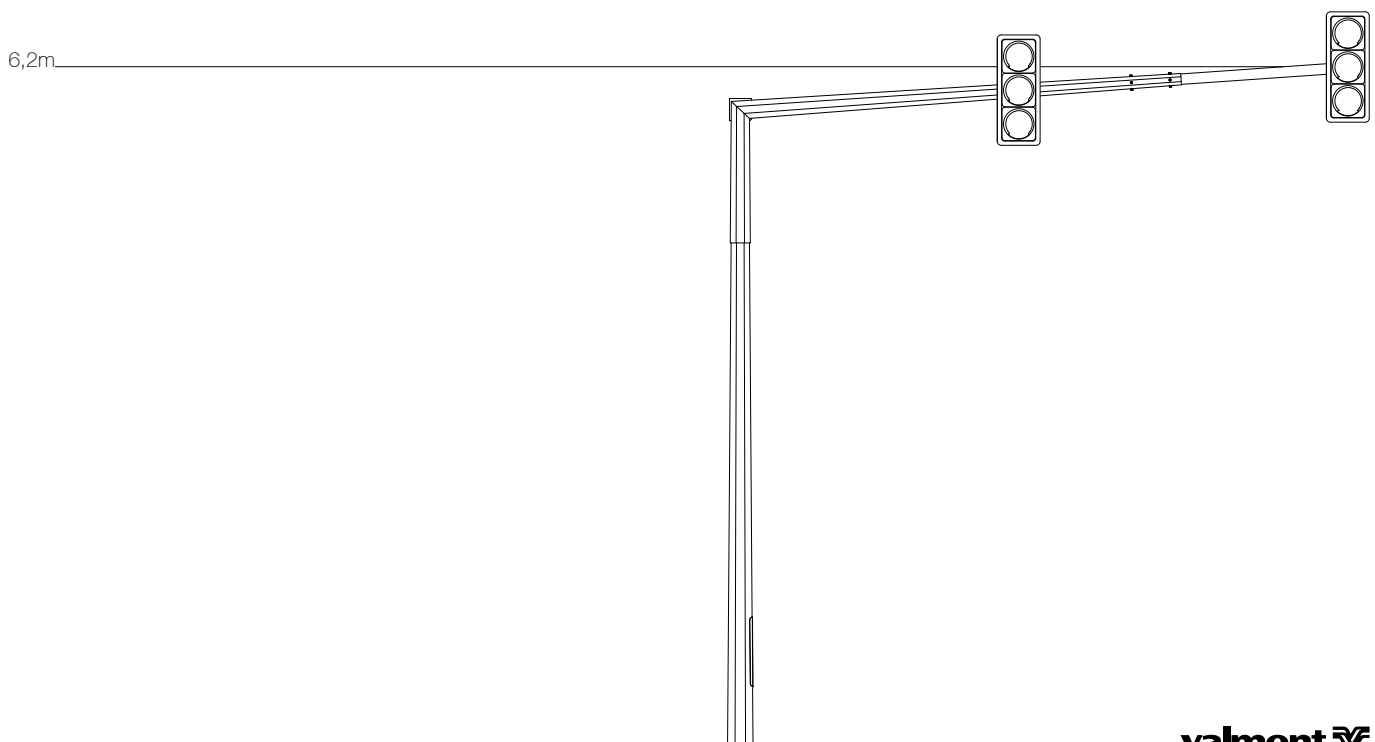

Traffic

Overhead Traffic Signals

Traffic Signal Cantilever Masts: BD9407 Specification.

The standard mast in this range has a mounting height of approximately 6.5m, with a maximum outreach of upto 8.5m, and can typically carry upto four Traffic Signal heads, evenly distributed of the cantilever arm. These masts are usually designed and manufactured to suit each contract specification and require specialised BD9407 and Highways England compliant anchorage systems that are capable of withstanding the masts ultimate resistance moment (M_R - typically = 218.7 kNm) and ultimate shear load (F_R - typically = 437.3 kN).



Dimensional Information

Flange Plated Option

| Height (m) | Projection (m) | BD (mm) | TD (mm) | DH x DW (mm) | SL x T x BC (mm) | Anchor Bolts | Mass (kg) |
|------------|----------------|---------|---------|--------------|------------------|--------------|-----------|
| 6,5 | 8,5 | 420 | 114 | 600 x 115 | 870 x 45 x 560 | M39 x 1400 | 740 |

Dimensions and technical information given as an indication.

See diagrams beginning on page 308 for info regarding the moments and abbreviations used in above tables.

Valmont reserves the right to make, without delay and without prior notice, the technical or aesthetic modifications that it deems necessary to improve the products of the Standard Collection.

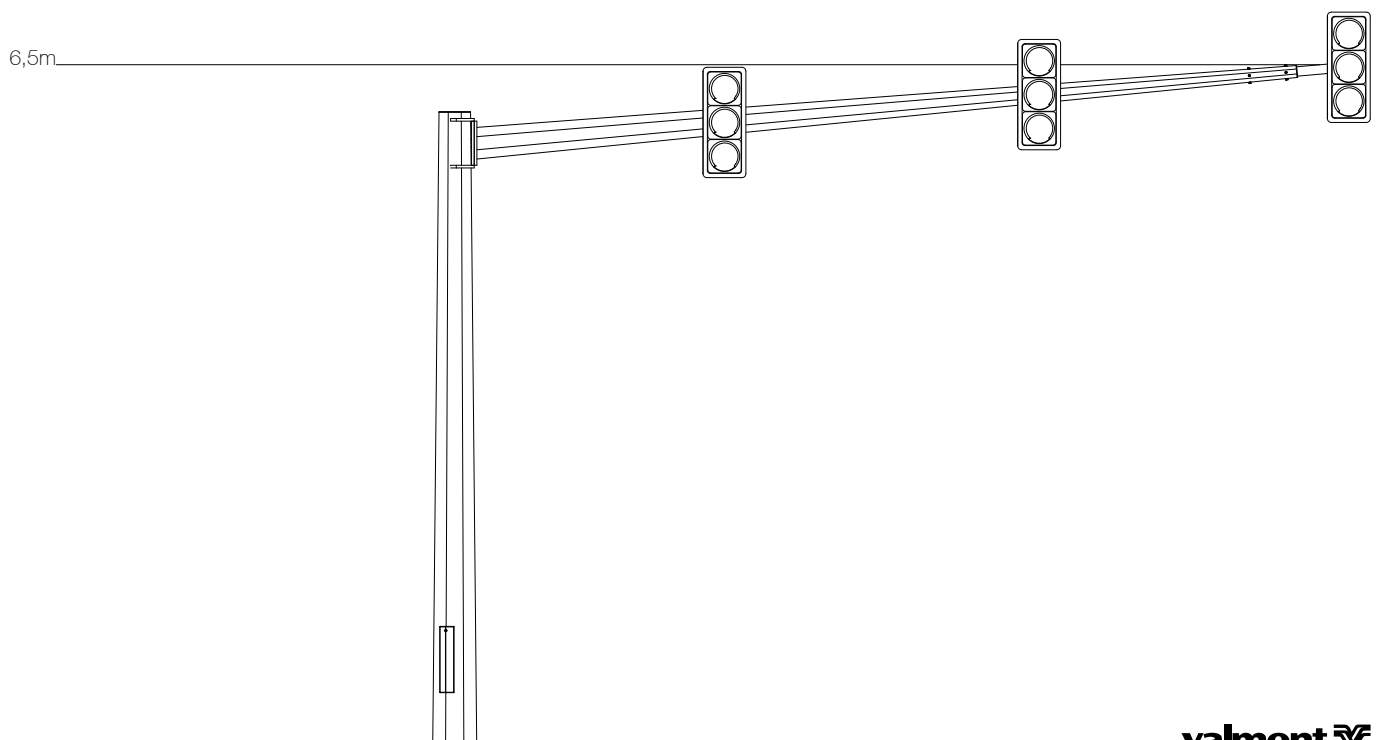

Utility

Transmission and Distribution Columns

Our Power Starts With You.

In most parts of the world, power delivery has become so reliable that we don't think twice when a light switch is flipped or a mobile device is charging.

That level of global reliability didn't happen by accident. We know because we helped create it. For decades, Valmont Utility has partnered with utilities and distributors around the globe providing power transmission and distribution towers, as well as substation structures and composite components.

We understand that no two lines are the same. Whether 11kv distribution or 400kv transmission you need customizable and seamless solutions to keep your promise of reliable power 24 hours per day.



Power Where You Need It.

Every electrical transmission and distribution pole project is as unique as the site upon which it is installed. From steel tapered transmission poles and H-frames, to concrete and patented steel/concrete hybrid transmission poles, Valmont Utility provides custom-engineered solutions. Our sturdy, dependable structures utilize real-world test results to optimise designs that yield both the highest value and the most reliable solution for our customers.

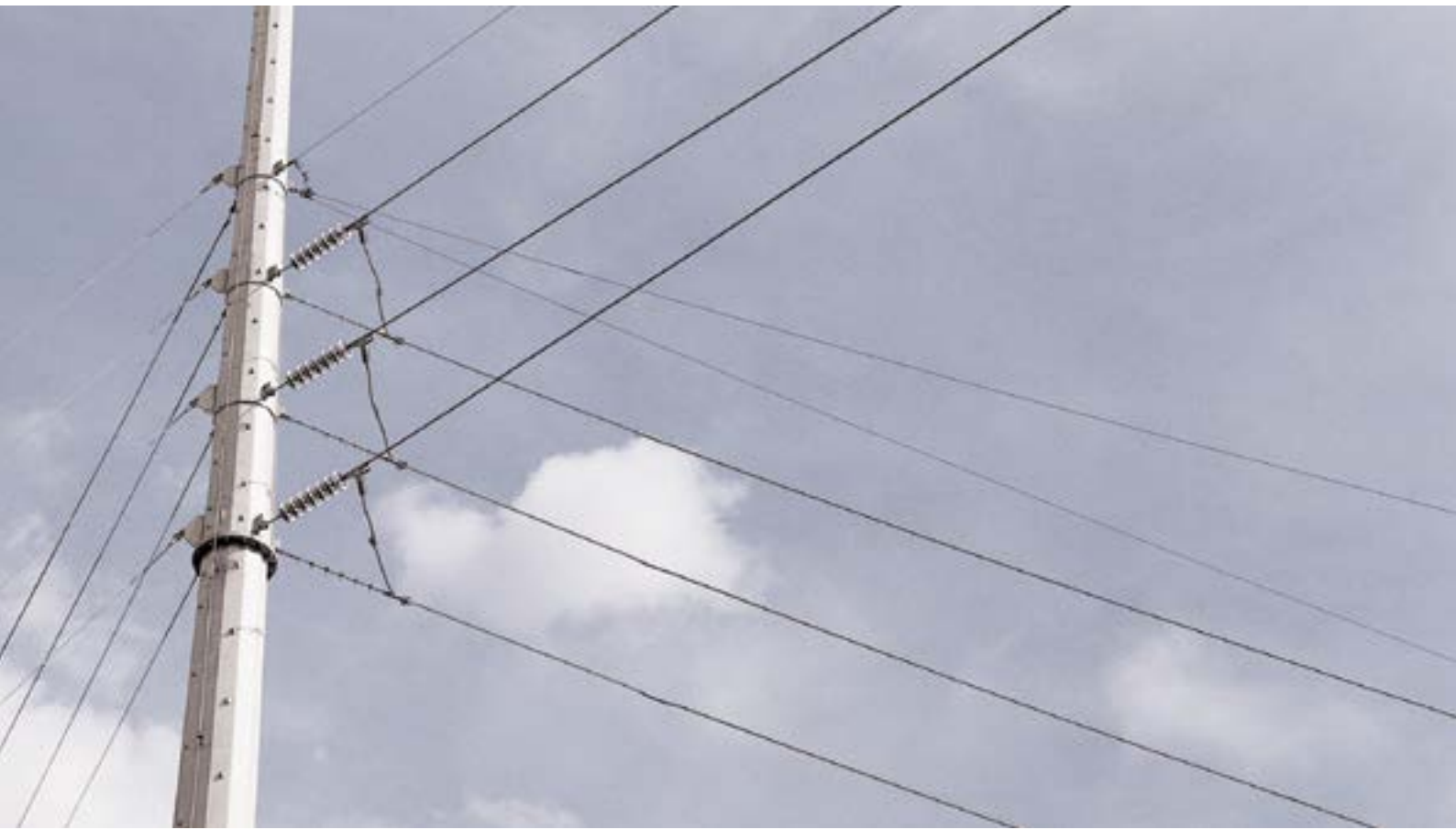

Proven Performance, Global Solutions.

Valmont Utility supports electric power utilities with the transmission of power from generation facilities to the end-consumer through the custom design and manufacture of transmission, sub-transmission and distribution poles as well as with electric substation structures.



Tramway Poles

Keeping Pace With Population Growth...

Urban population growth is spurring transportation management officials to seek innovative and reliable infrastructure for mass transit applications.

Global Resources, Local Expertise.

Valmont has provided structural components for tramway systems across the UK, Europe, North America and in Africa.

With a passion for conserving resources and improving life, Valmont Stainton is uniquely qualified to design, manufacture and deliver quality urban mobility structures to help ease transportation congestion while reducing pollution and the carbon impact of travel.

Valmont RCM Poles.

Valmont offers a patented RCM (multi-sided, conical / round-tapered) pole that reduces the pole's base size at ground level as compared to alternative masts.

Through the implementation of RCM catenary support masts, transportation managers have improved pedestrian space and access to the edge of the tram.





An In-depth Range Of Solutions.

Valmont transit structures include overhead traction/tramway/catenary poles in a variety of shapes and sizes, as well as signal structures and transition poles.

In addition, Valmont Stainton can design and produce the area lighting structures, platform lighting columns, signposts and bollards at stations along the line.



Telecom Masts

Monopoles and Distributed Antenna Solutions

Keeping You Connected.

Valmont has global expertise in addressing the monopole and structural accessory needs of the telecommunications industry. Our monopoles are renowned for their durable designs and serve as the backbone for modern wireless communication systems.

Leveraging a solid foundation of in-house, engineering excellence, Valmont Stainton can design and manufacture structures which address tough technical challenges in most environments.

With addition of the largest rigging factory in Europe, and full PIM chamber testing facilities (horizontal and vertical), we are the smart choice for one stop telecom product supply.



Distributed Antenna Solutions.

Valmont provides small cell tower, Wi-Fi network system columns, and distributed antenna system (DAS) solutions for outdoor spaces.

These structures can be engineered to visually complement adjacent architectural elements, such as decorative light poles, using a variety of materials which Valmont offers - including steel, aluminium, and decorative wood.

Small communication towers and DAS poles can improve coverage and capacity in a specific geography while facilitating spectrum efficiency.

Further, with low centers of radiation, DAS poles enable Valmont customers to quickly install a network that can provide clear signals with minimal ambient environment interference. Both planted root and flange plated street poles are available along with roof mounted option, if required.



Smart Columns Internal Lighting

Internally Lit Columns.

Traditionally, a lighting column is viewed as support structure for an overhead light source. In today's modern, urban environments lighting columns themselves can often become the light sources.

Valmont offers internally lit columns through cooperation and partnership with industry leading lighting manufacturers whose speciality is lighting integration.

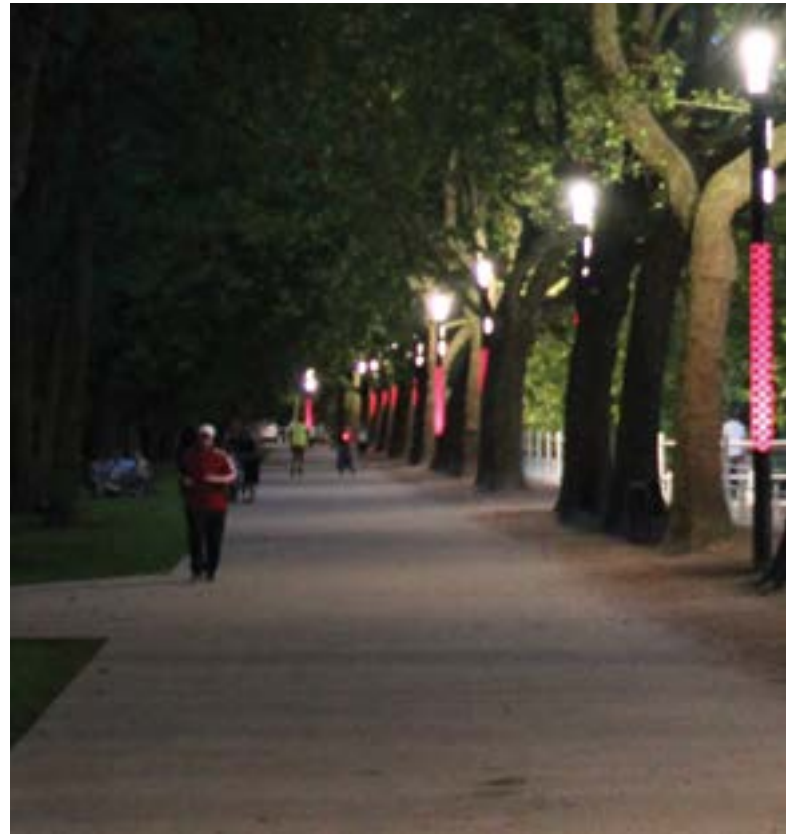

Creating City Landmarks.

Internal lighting can be used to transform a column into a beacon to mark special locations or identify important events.

Internally lit columns can be programmed to highlight the colours of your city or even your local football club.



Beyond Standard.

Internally lit columns can add more than just a decorative touch to your project.

Internally lit columns can be used to make busy roadways safer for travel. Installing internally lit columns around busy roundabouts or sharp curves can give drivers a visual cue and help them stay alert.

The image to the right showcases internally lit HE3 100 passively safe lighting columns.



Smart Columns Multifunctional Urban Furniture

The Functionality Your City Needs.

As cities become more and more densely populated space will become increasingly valuable. In the cities of the future, will a lighting column that simply supports a lantern be seen as valuable?

We at Valmont believe that added value solutions will be the way forward. For that reason, we have developed a range of smart columns that are designed to help people stay connected while they enjoy the public space.

- Smart Lighting
- Security
- CCTV
- Audio
- Digital Signage
- Environmental Sensors
- USB Charging
- Wireless Charging
- PV Solar Cells
- WiFi, 4G, 5G Base Stations
- EV Charging



Modular By Design.

Valmont Smart Columns are designed with modularity in mind. A wide range of components and features can be chosen based on the needs of the project.

In addition to a choice of functions, Valmont also offers a range of profiles and materials. Wood, steel, square, round, rectangular, the choice is yours.



Flexibility You Can use.

Valmont understands that every project is different, and that each city has its own needs. Where some may view this fact as a challenge, we see it as an opportunity.

Valmont has the capacity to design and deliver metalwork to house the smart systems you need. Do you have bespoke equipment that needs an expertly designed home? Contact your local Valmont representative and see what's possible.

Smart Columns Multifunctional Urban Furniture

Jalousie

A sculptural column that can be customized to match the aesthetic of the installation site. The column is internally lit and creates a powerful statement both day and night.

Jalousie is comprised of a customizable perforated base section and a specially designed aluminium profile. The perforations allow the columns internal lighting to shine through while the extruded profile make aiming lanterns simple and easy.

Structural aluminium with laser perforation.
Extruded aluminium profile with 4 technical rails.
Eliss 2.0 + R90 for installation and adjustment of lighting.
Polyester powder coated finish.





Urban Enhancement.

Jalousie goes beyond the functionality of the standard lighting column and focuses on the end user experience to enhance the urban environment.

Jalousie can be fitted with an internal speaker and a CCTV camera. The speaker can be used to create atmosphere or to convey information while the CCTV camera helps ensure pedestrian safety.



Transportation Electric Bus Charging Columns

The Future Coming.

The public transportation industry is on the verge of a monumental shift from diesel to electric power. Electric buses are becoming more and more common across the European Continent. This trend is expected to continue as cities and countries search for ways to reduce their greenhouse gas emissions.

As a result, Valmont has worked closely with market leading power conversion experts like Heliox to develop a comprehensive range of Electric Bus charging solutions.

Flexibility To Meet The Needs Of Your City.

Column based bus charging stations come in two main forms. Both designs rely on the pantograph system which has a long standing record of reliability. The main difference is the location of the pantograph.

Valmont proudly offers charging solutions for both column mounted and vehicle mounted pantographs. Our charging columns have been carefully designed for easy installation followed by years of worry free service.

Valmont has worked closely with market leading power conversion experts to design a comprehensive range of Electric Bus charging solutions. Our solutions are designed to rapidly and safely charge electric buses either on route or at the depo.

**Contact your local representative for additional information on these cutting edge solutions.*

Column Mounted Pantographs.

Our column mounted pantograph system uses the OppCharge interface. In this design, all moving parts are housed in the column. The automatic interface is based on established industry standards, with the intention of supporting a common charging interface primarily for commercial vehicles.

Fully scalable solution with power up to 600kW

Multiple arm lengths are available.

Standard clearance height of 4.5m.

Charging is fully automatic and secured by a two-way WiFi communication sequence.

Column designed in partnership with Heliox.





Roof Mounted Pantographs.

The Roof Mounted pantograph interface offers a reliable connection with up to 600kW without the fuss of sensors and wireless communication, the roof mounted pantograph is often chosen for its reliability & cost benefits.

Fully scalable solution with power up to 600kW
Available in single and double arm configurations.
Multiple arm lengths are available.
Standard clearance height of 4.5m
Column designed in partnership with Heilox.

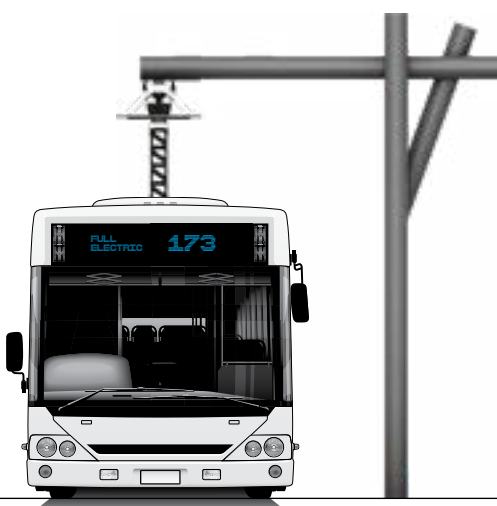

heliox

valmont 
STANTON

Heritage Products

Heritage Product Supply

Heritage Products.

Valmont Stainton combines in excess of 40 years of UK manufacturing experience and our unmatched product knowledge to produce beautifully unique and distinctive heritage lighting columns.

Our Heritage lighting products give a traditional appearance and can further enhance areas of an historical nature.



Designed To Last.

Valmont Heritages columns can be structurally designed to suit most applications including additional attachments i.e. hanging baskets, banner arms & festive decorations.



Beautifully Adaptable.

Columns can be supplied for both post top or single and twin lantern mounting applications with cast iron pedestal bases, swage joint, shaft ring and ladder bar embellishments to give a traditional design appearance.

Take A Break, You've Earned It.

Valmont Stainton offers a selection of seating solutions for various applications seen in today's cities.

No matter if you just need a few moments to make a quick phone call or if you would rather sit in the park and enjoy your lunch. Valmont Stainton has a seating solution for you.

The Inari Bench.

Modelled after our Inari range of wooden columns, the Inari bench uses a simple cylindrical profile to create a comfortable place to rest.

Available in both steel and steel / wood combinations.

Length can be adjusted up to 4m to fit project needs.

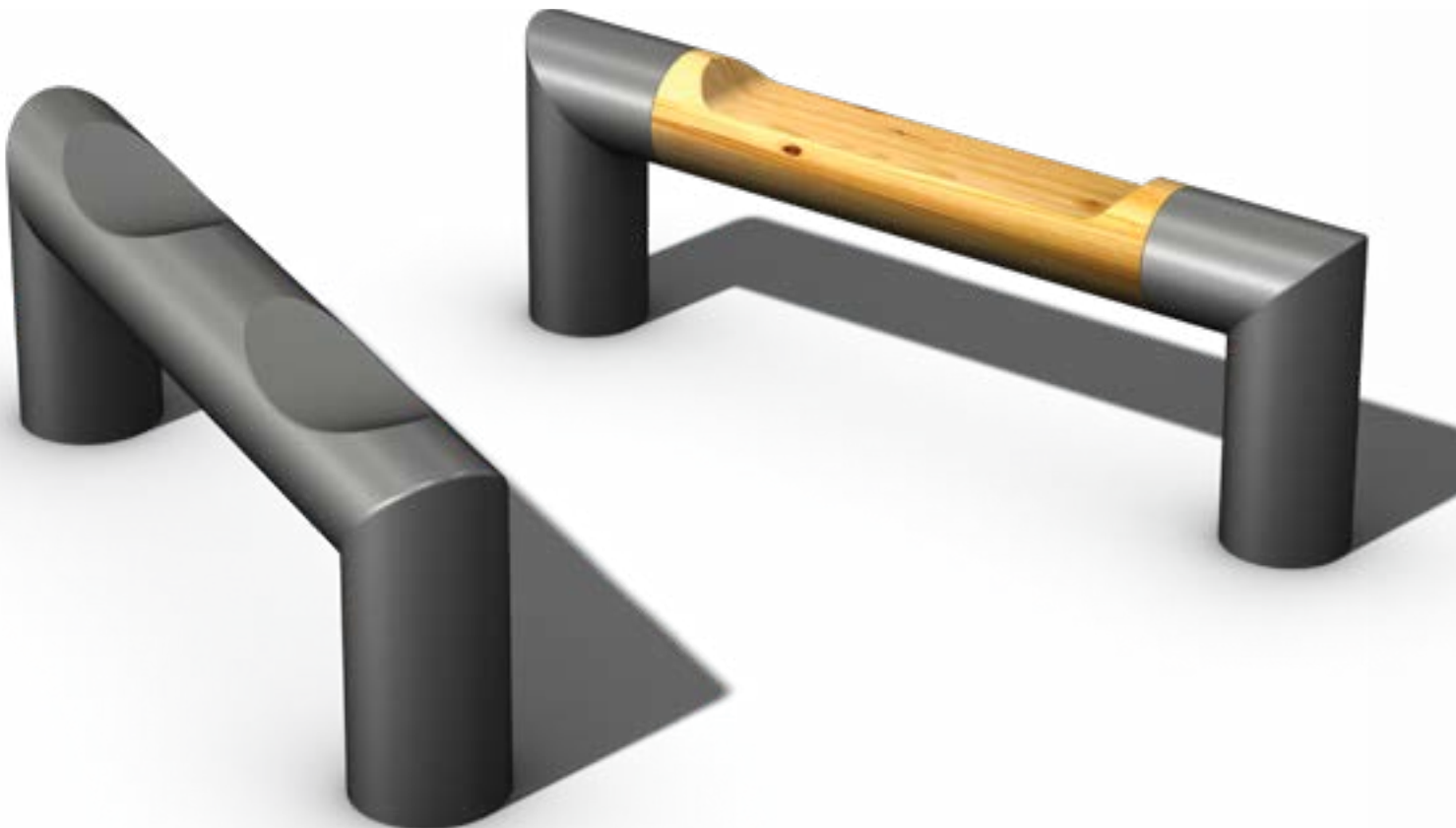
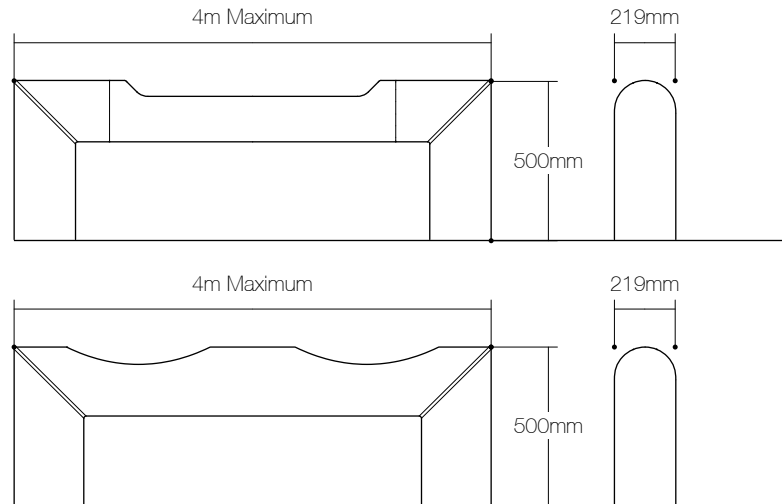

The Kulma Bench.

A modular seating design constructed from steel and PEFC certified timber.

The Kulma bench is available in multiple configurations and can be internally lit with an LED RGBW system.

Multiple graphics as well as bespoke designs are available for the internally lit accent.

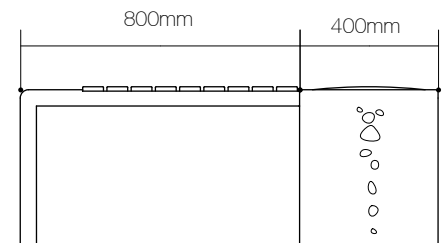
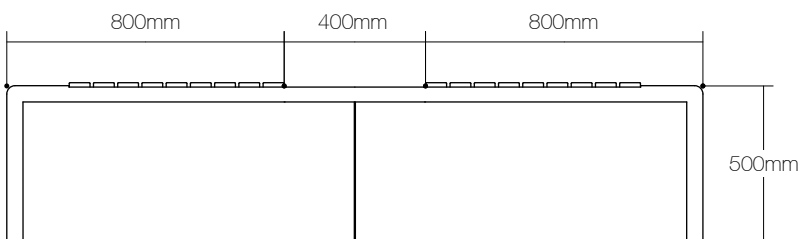
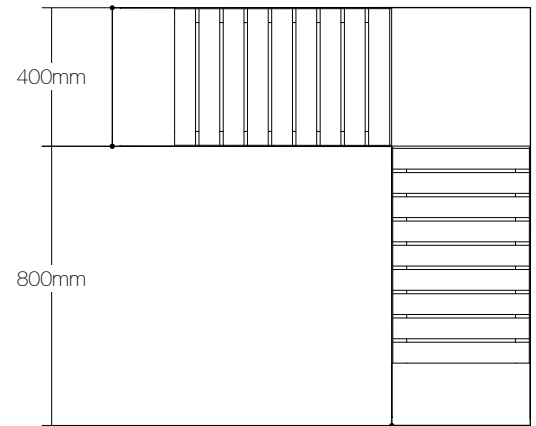

Dimensions and technical information given as an indication.

Valmont reserves the right to make, without delay and without prior notice, the technical or aesthetic modifications that it deems necessary to improve the products of the Standard Collection.

Furniture

Seats and Benches

Taking Advantage of Natural Light...

As our days become more and more busy it is sometimes necessary to sit down and relax. Ombra provides a comfortable place to sit with an added twist.

Ombra uses natural sunlight or artificial light to cast vividly coloured shadows on the ground, nearby objects, and even pedestrians. As the sun moves across the sky the shadows follow creating dynamic patterns that change from hour to hour and month to month.

Ombra is constructed from hot-dip galvanised steel, PMMA panels, cast concrete foundation, and a PEFC certified seating surface. PMMA panels have been specified for their durability, and resistance to UV radiation, heat, and chemical agents. Multiple colours are available upon request.

The steel components come standard with a baked polyester powder coat. The wooden surfaces are treated with a 5 layer protective coating system.

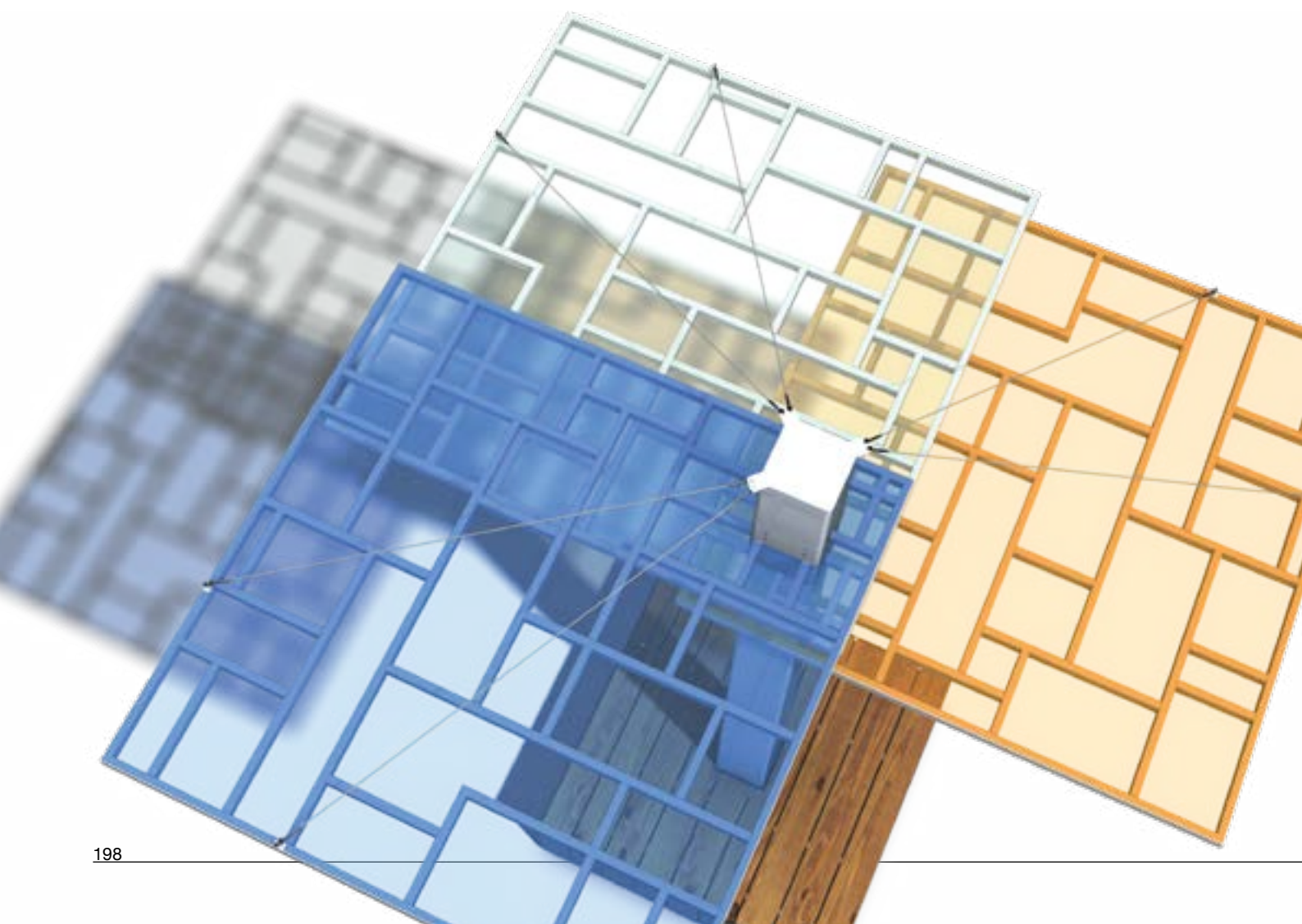
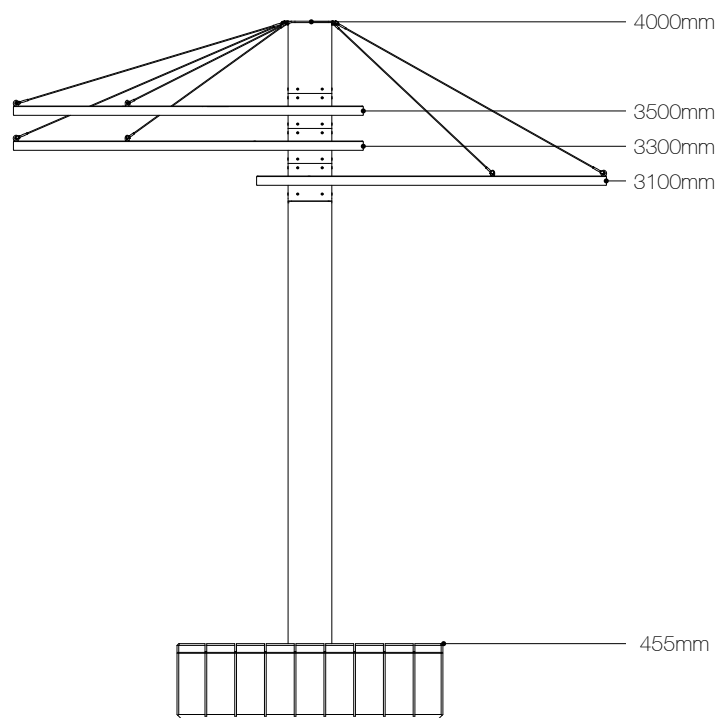



Dimensions and technical information given as an indication.

Valmont reserves the right to make, without delay and without prior notice, the technical or aesthetic modifications that it deems necessary to improve the products of the Standard Collection.

Furniture Bollards

The Final Piece Of The Puzzle.

Valmont Stainton offer a standard range of steel and wooden bollards which add a decorative touch as well as a functional benefit to your installation.

Valmont bollards can be used to mark pedestrian pathways and to help control traffic by creating both a visual and physical barrier. Valmont bollards are offered at a standard height of 1.2m, but can be adjusted to fit the needs of the project.

Wooden Bollards.

Valmont offers a range of wooden bollards that are based on our standard range of lighting columns.

All wooden Valmont wooden bollards are constructed from galvanised steel and PEFC certified timber.

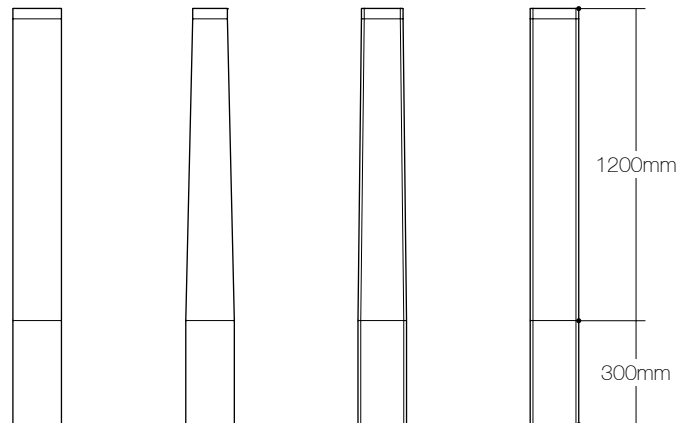

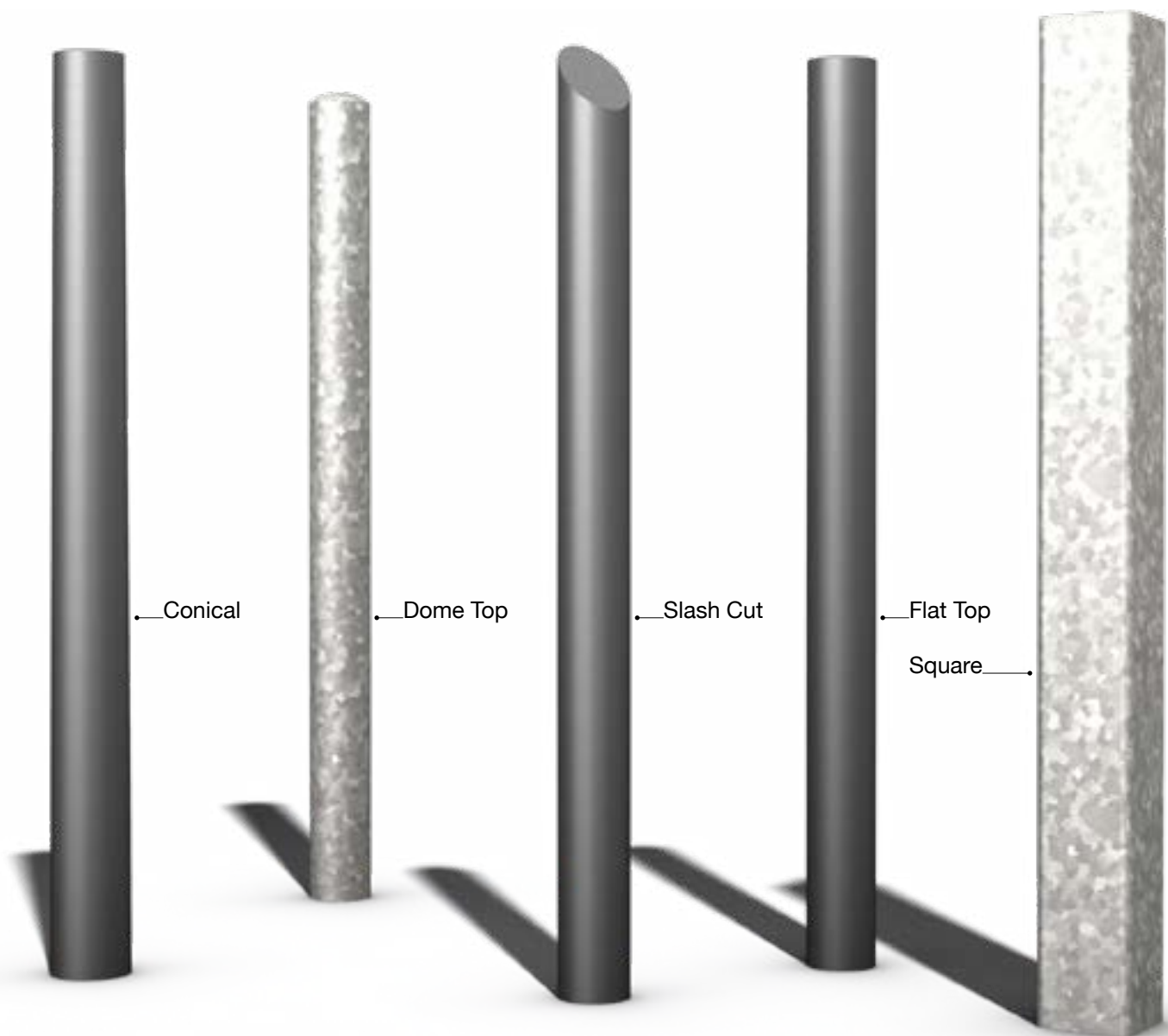

Steel Bollards.

Valmont also offers a simple range of steel bollards that are based on our standard range of lighting columns.

All Valmont steel bollards are hot dipped galvanised to BS EN ISO 1461, to protect against corrosion and ensure a long service life. Decorative finishes and bespoke bollard design are available on request.

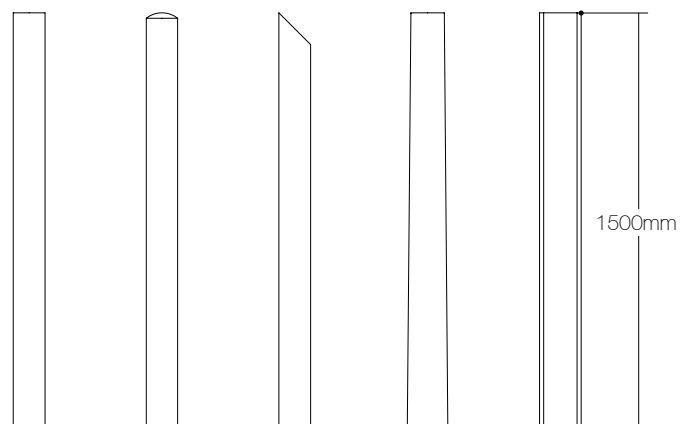

Furniture Tree and Column Guards

Protect Your Investment.

Accidents happen. The only thing you can do is be prepared. Valmont offers a range of tree and column protectors which are designed to protect your investments from cyclist, motorist and the occasional delivery driver.

Valmont column and tree protectors are constructed from durable, galvanised steel and are available in a range of styles, diameters, and finishes.

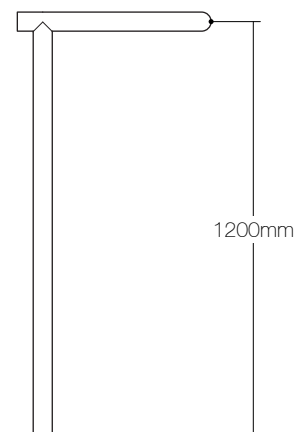
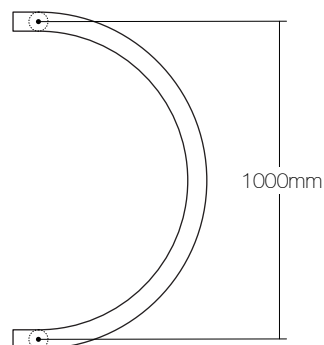
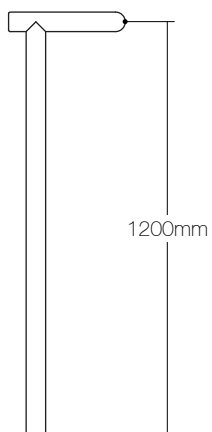
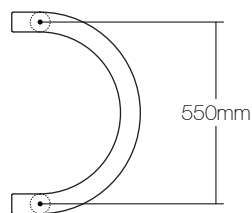

BiPod S

BiPod W

BiPod HD

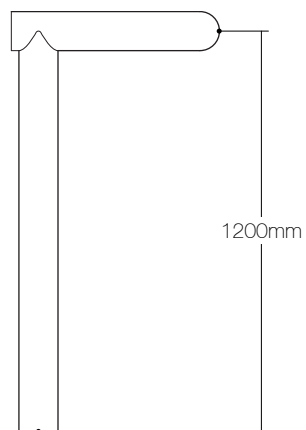
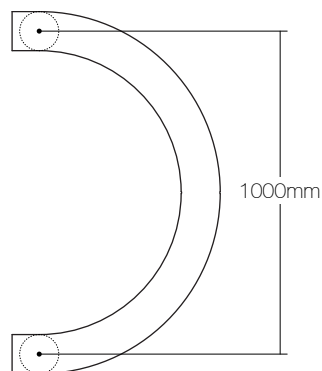

TriPod

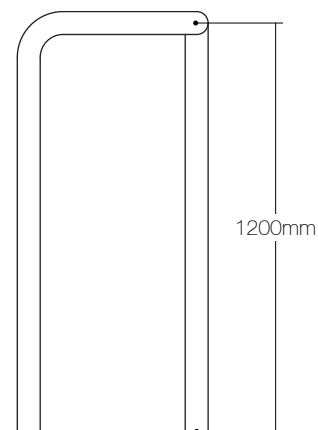
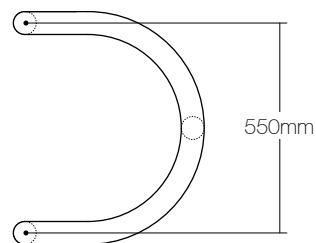

| Model | Pipe Diameter (mm) | Planting Depth (mm) | Guard Width (mm) |
|----------|--------------------|---------------------|------------------|
| BiPod S | 60 | 800 | 550 |
| BiPod W | 60 | 800 | 1000 |
| BiPod HD | 114 | 800 | 1000 |
| TriPod | 60 | 800 | 550 |

Dimensions and technical information given as indications, consult your Valmont Stainton representative for addition information.



TriPod



BiPod HD



BiPod S

Sign Posts Traffic Sign and Signal Posts

Helping to deliver the information you need...

Our cities and motorways are more crowded than ever. Motorist and pedestrians both depend on well placed information to help keep them safe and moving in the right direction. Valmont Stainton offers a wide range of signposts and accessories to ensure the information you need is where you need it to be.

*Tubular signposts in both aluminium and steel

*Designed to EN12899

*Stepped (wide based) tubular signposts.

*Cranked signposts.

*Cantilever signposts.

*Bracket arms

*Sign clips

*End caps

*Fixing products



One Stop Shop...

Valmont Stainton can provide you with all the necessary products to complete your project. Contact your local representative to see how Valmont Stainton can help.

Circular Tubing

| Size (mm) | 50 | | 60,3 | | 76,1 | | 88,9 | | | 114,3 | | | 139,7 | | | 193,7 | | | 219 | | | 244,5 | | 273 | | |
|-----------|-----|-----|------|-----|------|-----|------|-----|------|-------|-----|------|-------|------|------|-------|------|------|------|------|------|-------|------|------|------|------|
| Wall (mm) | 3 | 4 | 3 | 4 | 3 | 4 | 3,2 | 4 | 5 | 3,2 | 3,6 | 5 | 4 | 5 | 6,3 | 5 | 6,3 | 8 | 5 | 6,3 | 8 | 6,3 | 8 | 6,3 | 8 | 10 |
| kg / m | 3,4 | 4,5 | 4,2 | 5,6 | 5,4 | 7,1 | 6,4 | 8,4 | 10,3 | 8,8 | 9,8 | 10,3 | 13,4 | 16,6 | 20,7 | 23,3 | 29,1 | 36,6 | 26,4 | 33,1 | 36,6 | 37 | 46,6 | 41,4 | 52,3 | 99,1 |

Square Tubing

| Size (mm) | 50 x 50 | | 60 x 60 | | 76 x 76 | | 80 x 80 | | 100 x 100 | | 120 x 120 | | 160 x 160 | |
|-----------|---------|-----|---------|-----|---------|-----|---------|------|-----------|------|-----------|------|-----------|--|
| Wall (mm) | 3 | 4 | 3 | 3,2 | 4 | 3 | 4 | 5 | 5 | 5 | 5 | 5 | 5 | |
| kg / m | 4,5 | 5,4 | 5,3 | 7,3 | 9 | 7,1 | 9,2 | 14,4 | 17,7 | 23,8 | 23,8 | 23,8 | 23,8 | |

Rectangular Tubing

| Size (mm) | 100 x 50 | | 120 x 60 | | 120 x 80 | | 150 x 100 | | 160 x 80 | | 200 x 100 | | 250 x 150 | | 300 x 200 | | | 400 x 200 | | 450 x 250 | | |
|-----------|----------|------|----------|------|----------|------|-----------|------|----------|------|-----------|------|-----------|-----|-----------|------|-----|-----------|-----|-----------|-----|-----|
| Wall (mm) | 4 | 4 | 4 | 4 | 4 | 5 | 6,3 | 5 | 6,3 | 5 | 6,3 | 6,3 | 8 | 6,3 | 8 | 10 | 8 | 10 | 8 | 10 | 10 | 10 |
| kg / m | 8,9 | 10,7 | 11,7 | 18,3 | 22,4 | 17,5 | 21,4 | 22,3 | 27,4 | 37,2 | 46,9 | 47,1 | 59,1 | 72 | 71,8 | 88,6 | 106 | 106 | 106 | 106 | 106 | 106 |



Applications Guide



Project Lead: Thorn UK | Installation: Inverness Campus

Parks and Public Spaces
Railway Stations
Hospitals
City Centres
Airports
Highways



Parks and Public Spaces

A place for relaxation and recreation...

Public parks or municipal gardens provide city residents and visitors a chance to step out of the busy city streets and into a relaxing green space.

City parks often offer a wide range of features which require specific lighting solutions.

- *Fitness trails and pathways.
- *Children's playgrounds or picnic areas.
- *Large open areas.
- *Historic monuments or public art.



Fitness trails and paths:

Pedestrian level columns from 3 to 5 metres are perfect for this application. Valmont offer a wide range of pedestrian level columns manufactured from steel, aluminium, and even wood.



Diva²
Page 84



CityQuartz
Page 50



Inari
Page 102

Playgrounds areas:

Slightly larger areas requiring taller columns to create even fields of light. Valmont offer a wide range of 6 to 8 metre columns in both post top and bracket mounted configurations.



Mersey
Page 132



Sillem
Page 90



Fluance
Page 46

Large areas, monuments, and public art:

Depending on the application, flood lighting or accent lighting may be appropriate. Large fields of even light or focused beams to highlight important features. The choice is yours.



XHD Column
Page 60



Altor HD
Page 44



Katio
Page 124

Railway Stations

A high energy area...

Railway stations are busy areas with many different lighting needs. Lighting can be used to accent architectural features as well as to help direct commuters quickly and safely through the station.

While all railway stations are different, there are many common themes.

- *Main entrances and high traffic areas.

- *Large open areas.

- *Commuters need to be able quickly navigate the area and find their destinations.

- *Creating a distinct Identity... Railway stations are often seen as icons in busy city centres.



Entrances, high traffic areas, and large, open areas:

10 to 14 metre columns in steel or wood can be used in combination with multiple floodlight arrangements to illuminate large areas and ensure there is enough light in high traffic areas.



Altor LD
Page 42



Corten
Page 138



XHD Column
Page 60

Pedestrian level lighting:

Smaller columns at heights of 3 to 4 metres can be used to light paths of ingress and egress. This can help commuters with wayfinding by providing them with a visual path to follow.



Candella
Page 82



Koli
Page 108



ROTA
Page 156

Eye-catchers or bespoke lighting columns:

Highly decorative or even bespoke columns can be used both inside and outside the station to create visual impact. With a wide range of materials available and design support standing by, Valmont is ready to transform your concept into a reality.



Bespoke Wooden Columns
Page 126



Tree Columns 2
Page 54

Hospitals

Large and complex with wide range of lighting needs...

Hospitals often cover large campuses and require lighting solutions for many different applications. Valmont offers a wide range of columns in multiple materials that are designed to meet the needs of any project.

No matter the application or budget, Valmont has the right product for the job...

*Entrance roads and high traffic areas.

*Car parks.

*Low traffic and refuse areas.

*Building entrances and pedestrian areas.



Entrances roads and high traffic areas:

Entrance roads to the hospital must be well lit to ensure the safe arrival and departure of staff, emergency crews and visitors. 6 to 8 metre passively safe columns, standard aluminium columns, or wooden columns are suited perfectly for this application.



Passive Safety
Page 62



Anapurna
Page 92



Pallas
Page 100

Car parks and refuse areas:

Depending on the situation, multiple solutions to parking and refuse area lighting may be required. Valmont offers large columns for area lighting as well as hinged columns for car parks with limited access for maintenance crews.



ROTA
Page 156



SWT Conical Steel
Page 38



Tubular Steel
Page 30

Walkways, entrances and pedestrian areas:

Walkways from parking areas can be lit with decorative wooden columns while main entrances and outdoor social areas can be marked with taller accent lighting columns.



Bespoke Wooden Columns
Page 126



Ruka
Page 112



VriPod
Page 70

City Centres

The heart of the city...

City centres are bustling pedestrian areas which often serve as the main commercial area of the city. Shops, restaurants, museums, and architectural landmarks are all common in the City Centre.

With such a wide range of lighting applications City Centres are an ideal place to mix and match products to create a unique and dynamic atmosphere.

- *Pedestrian areas for shopping and dining.
- *Open markets and squares.
- *Historic architectural sites or monuments.
- *Creating or contributing to a city's unique identity.



Pedestrian areas:

Small lighting columns can be used to light busy pavements and cycle paths. Using relatively low light points can help to create an intimate atmosphere.



SWT Conical Steel
Page 38



Diva²
Page 84



Idyline
Page 86

Open markets and squares:

Many city centres have large open spaces which can be used for open air market, and special events. Valmont offers a wide range columns which are designed to support multiple floodlights and projectors ensuring that landscape architects and lighting designers have the necessary tools to realize their visions and bring the city centre to life.



XHD Column
Page 60



Raked Column
Page 58



Altor HD
Page 44

Creating an identity:

Lighting columns can also be used as a landmark in their own right. Valmont has a wide range of eye-catching lighting solutions that can be used to create or enhance the city identity.



Bespoke Wooden Columns
Page 126



Diamond Column
Page 56



Sillem
Page 90

Airports

Cities within themselves designed around efficiency...

Airports are incredibly complex and busy areas requiring a wide range of lighting solutions. Most airports are divided into landside and airside areas. Landside areas contain access roads, passenger pick-up and drop-off areas, parking areas, and public transportation stations. Airside areas are those which are only accessible to aircraft including runways, taxiways, and aprons. Each area within the airport has specific lighting needs.

*Access roads

*Passenger pick-up and drop-off areas

*Car park and service areas

*High Mast applications



Access roads, passenger pick-up / drop-off areas:

Airports see massive amounts of traffic day and night. It is important that access roads are well lit to facilitate safe and efficient transit.



Passive Safe
Page 62



Evolution
Page 80



Seka
Page 120

Parking and service areas:

Airports often have large parking areas along with parking decks for passengers and car rentals. These areas may be outdoor lots or multi-level decks. No matter the application, Valmont has a range of columns that are suited for the job.



Tubular Aluminium
Page 76



Tubular Steel
Page 30



Derwent
Page 152

High Mast applications:

Airports are very busy. Safety is of utmost importance. Valmont offers a wide range of High Mast lighting solutions which are designed around incredible strength, durability, and ease of maintenance.



Kartio
Page 124



Altor HD
Page 44



Malto
Page 172

Highways

Helping to keep your journeys safe...

Highways are the arteries that feed our modern cities. Today, commuters travel at high speeds and often in dense traffic. Quality lighting, signage and traffic monitoring all play an essential roll in keeping travellers safe.

- *Traffic Monitoring
- *Gantries for overhead signage
- *Easy access for maintenance
- *High Mast applications



Highways:

Modern motorways and principal routes see massive amounts of traffic moving at increasingly high rates of speed. Adequate lighting of these busy thoroughfares is an essential part of safe and efficient travel.



Monitoring traffic flow and delivering information.

Obviously, commuters have a place to be. Valmont produces a range of signpost, gantries, and CCTV columns that are designed to deliver information to both motorist and highway authorities.



High Mast applications:

In some cases, flyover's for example, may require exceptionally high light point heights. Valmont offers a wide range of High Mast lighting solutions which are designed around incredible strength, durability, and ease of maintenance.



Accessories



Hinges
Security
Banner Arms
Electrical Sockets
Flood Light Adapters
Functional Lantern Brackets
Decorative Lantern Brackets
Accent Lighting
High Mast Accessories



Hinges

Alto, Soprano, and Tempo

Hinges...

Gaining access to the inner workings of your lighting column is an essential part of product maintenance.

Valmont offers a range of hinge options that are designed with ease of use in mind.

*Valmont hinges can be installed on steel, aluminium, and wooden columns.

*The column door remains attached to the hinge to reduce the chance of damaged or lost parts.

Alto.

Interior hinge fitted with a retractable end stop which allows the inspection door to be opened vertically and kept open.

The system can be installed on all types of columns from Ø125mm at the top of the door.

(Steel, Aluminium & Wood)

Valmont Patent



Soprano.

Exterior hinge specially designed to give the most inside space and which allows the inspection door to be opened vertically and kept open.

The system can be installed on any type of column from Ø100mm, for a door height of 500mm.

(Steel, Aluminium & Wood)



Tempo.

The interior specially designed to give the most inside space and which allows the inspection door to be opened laterally and kept open, due to the three anchor point hinge design.

The system can be installed on any type of Steel and Wood column from Ø100mm, for a door height of 500mm.

(Steel & Wood)

Security...

Securing the inner workings of your lighting column is an essential part of product safety. Valmont offers multiple options for securely locking your columns to help prevent unwanted access.

*Security locks can be installed on steel, aluminium, and wooden columns.

Rei-Lux Screw and Screwdriver.

This unique off-centre cam design of the Rei-lux security bolt is both simple and effective, The patented design is operated using a specifically manufactured driver available in M8, M10 and M12 configurations.

This bolt arrangement can be installed on all types of columns (Steel, Aluminium, Stainless and Wood).

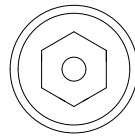
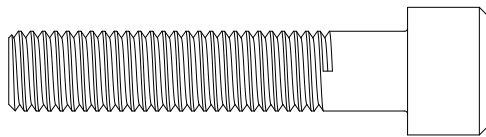
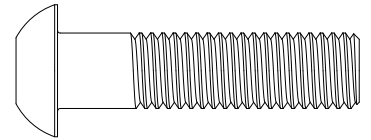
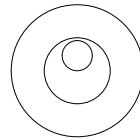

Security Pin Hex Screws.

Pin-in-Hex Socket screws feature a small metal post in the middle of the screw head that prevents a normal hex driver from engaging. Pin-in-Hex Socket screws can only be installed, or removed, with the correct bit or allen key.

This bolt arrangement can be installed on all types of columns (Steel, Aluminium, Stainless and Wood)

Triangular Head Screws.

The entry level anti-vandal security option in service for over 30 years, available in M8, M10 and M12 configurations.

This bolt arrangement can be installed on all types of columns (Steel, Aluminium, Stainless and Wood)

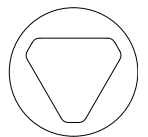
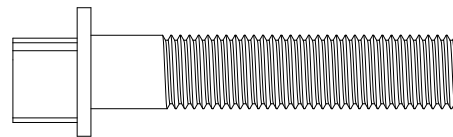

Vented Wrap Around Door

Valmont Stainton offers a selection of vented wrap around doors.

The doors can be installed on all types of columns no matter the profile or material (Tubular, Conical, Octagonal, Steel, Aluminium, Stainless and Wood).

Captive Wrap Around Door

Valmont Stainton offers a selection of captive wrap around doors.

The doors can be installed on all types of columns no matter the profile or material (Tubular, Conical, Octagonal, Steel, Aluminium, Stainless and Wood).

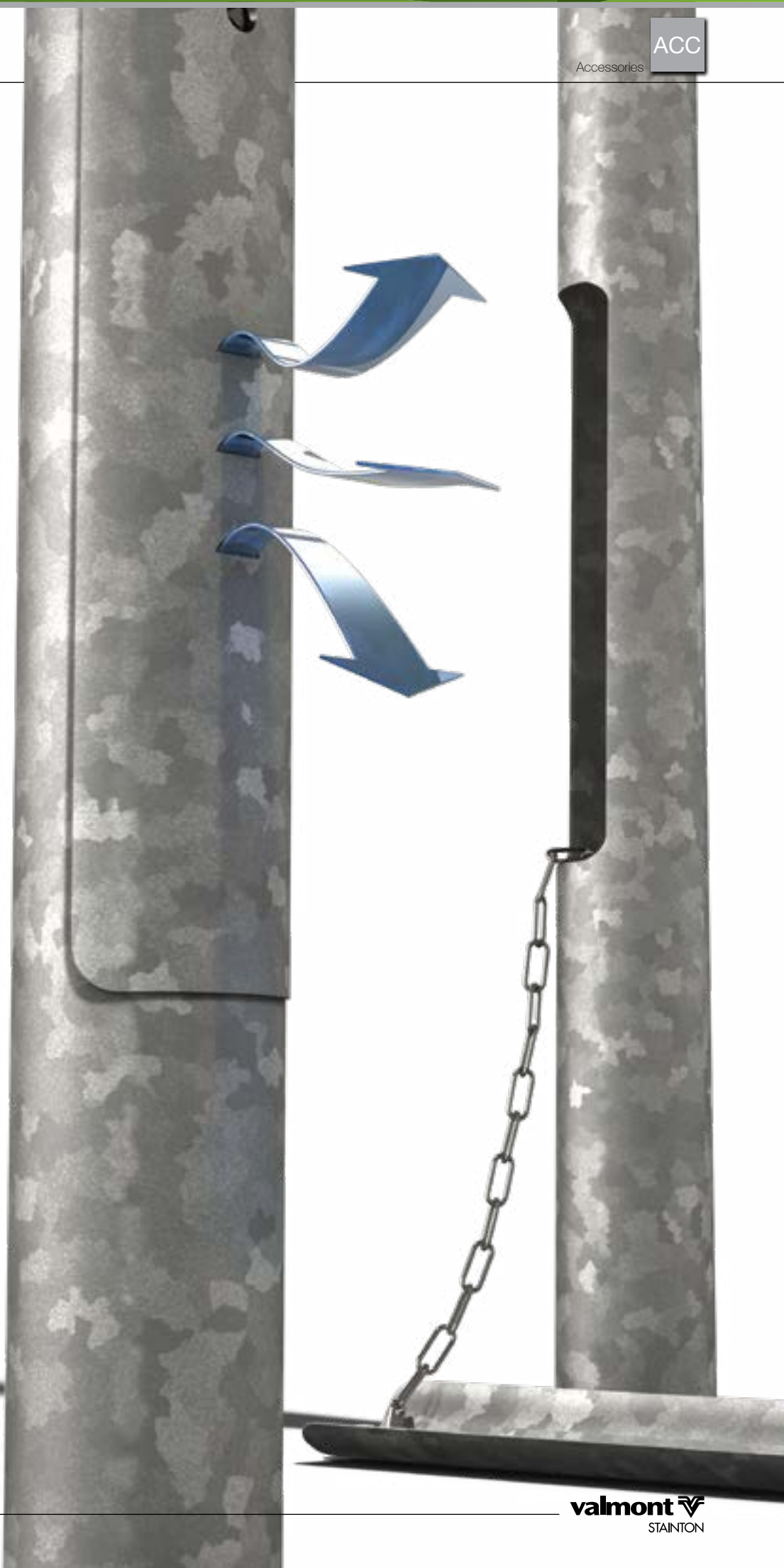

Banner Arms

Scargo System.

A re-usable fastening system used to attach a decorative banner to a column. Scargo is designed to relieve the strain on the column by partially releasing the banner if a predefined wind speed is surpassed.

Scargo can be used with both steel and aluminium banner arms $\varnothing 48/50\text{mm}$.

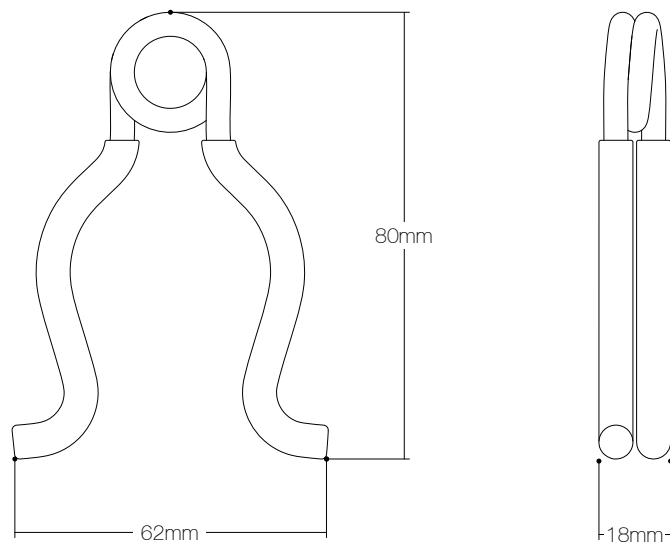

| Banner Dimensions (mm) | Wind Speed (km.h-1) |
|------------------------|---------------------|
|------------------------|---------------------|

| | |
|------------|------|
| 1200 x 600 | 75.6 |
|------------|------|

| | |
|------------|------|
| 2000 x 800 | 50.4 |
|------------|------|

| | |
|-------------|----|
| 3000 x 1000 | 36 |
|-------------|----|

| | |
|------------|------|
| 4000 x 500 | 43.2 |
|------------|------|

Dimensions and technical information given as indications, assuming the flag's centre of gravity to be 6m up.

Stainton Generic Banner Arm.

A removable banner arm system which connects through internally welded collars in the lighting column.

Banner arms supplied complete with welded eye nuts to give easy connection points for attaching your desired banner system.

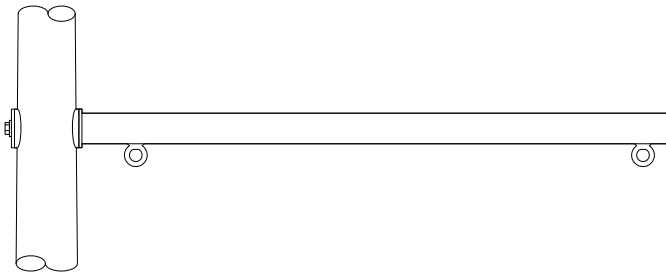

Banner arm dimensions are to be defined on a project to project basis. Please contact your Valmont representative for additional information.



Electrical Sockets Elec and Sound

Elec & Sound Accessory Plugs

These simple plugs give communities the ability to integrate the necessary connections for seasonal lighting and audio equipment directly into their lighting columns.

The Elec pack includes IP65 Class II factory pre-wiring, length 10m, 3G2, 5mm² (gauge to be recommended by the lighting manufactures).

The Sound pack includes IP65 Class II factory pre-wiring, length 10m, 2G1, 5mm².

The Elec pack and Sound pack are colour coded and designed to be incompatible with each other in a effort to minimise the chance of installation errors.

The plugs are suitable for both new installations as well as retrofits. Mounting the plugs is simple and only requires 2 items of hardware.

Available in Black and Transparent.

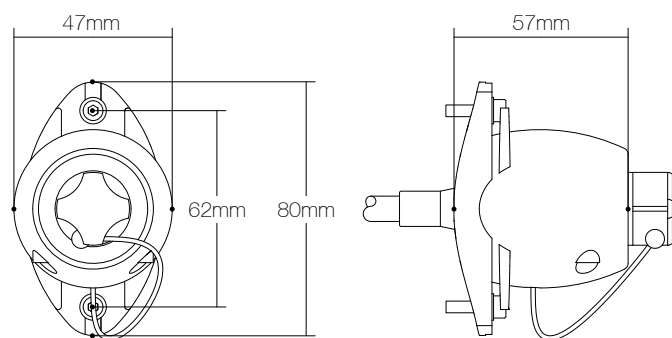

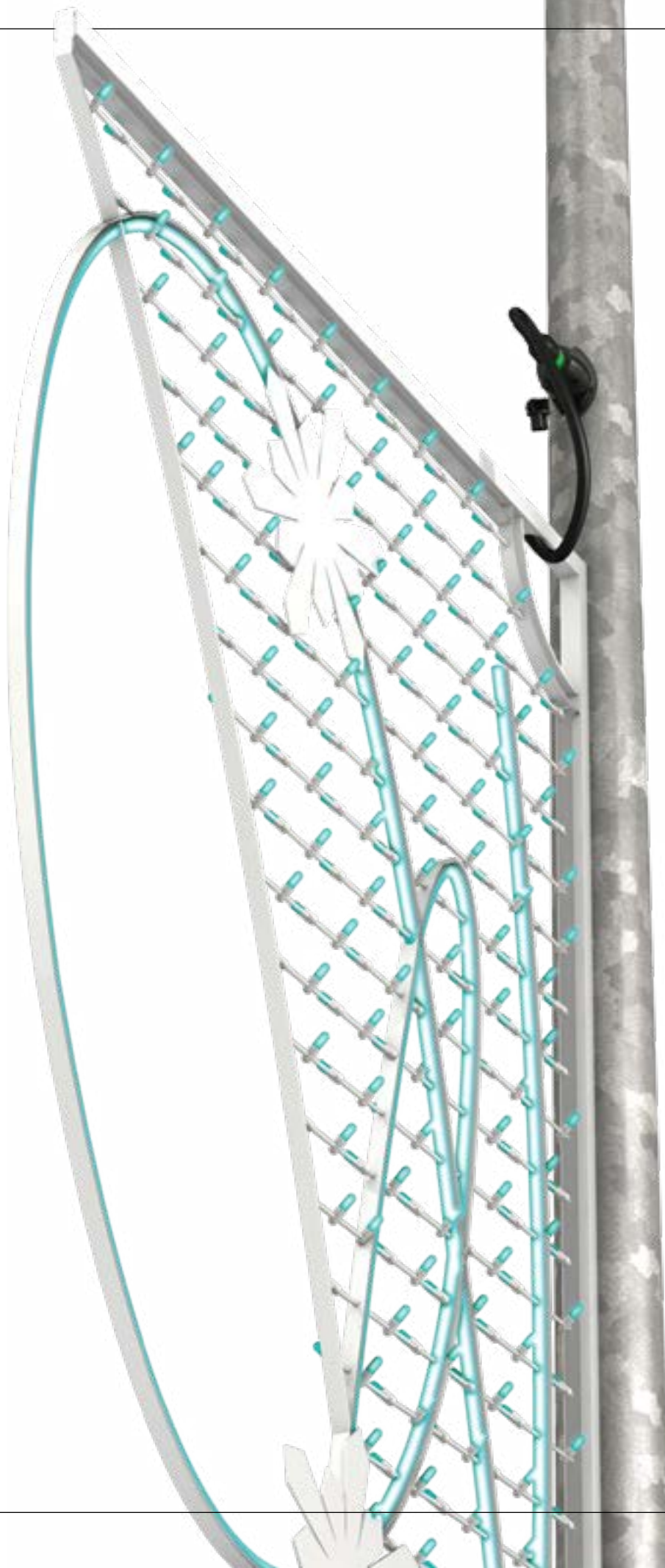

Flood Light Adapters

Eliss 2.0

Eliss 2.0

Eliss 2.0 is an adjustable flood light adapter that has been designed to exist in the space where form meets function.

Eliss 2.0 can be installed on any surface thanks to a clever spacer system and can easily rotated by up to 65 degrees in either direction. This flexibility makes Eliss 2.0 the ideal floodlight adapter when precision is a must.

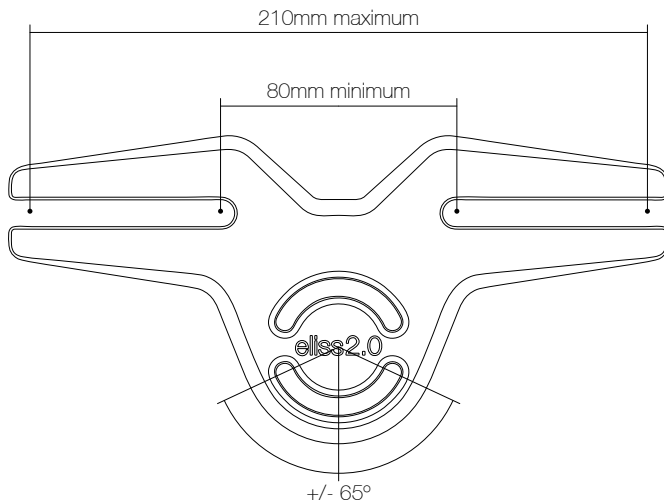

Flexibility.

The Eliss 2.0 is a versatile adapter which will pair well with a wide range of projectors from many manufacturers.

Adaptability.

Eliss 2.0 can easily be installed on practically any surface. Flat, round, small or large, the size and profile of the surface makes no difference.

R0

For installation on flat surfaces.

R53

For steel and aluminium mast $\varnothing 60$ and 76 .

R90

For steel and aluminium mast $\varnothing 180$.

B360

An aluminium ring for cylindrical and conical sections ranging from $\varnothing 76$ to 115mm .





B360

R53

Functional Lantern Brackets

Where Economy Meets Reliability.

Valmont Stainton provides a variety of complementary brackets to suit our range of products and match customer-specified requirements.

From simple single-arm bracket projections for suburban street lighting to vast sports-lighting headframe designs, Valmont Stainton strives to offer the best design solution for your needs.

The products shown below provide a brief overview of several bracket designs, however if you have a bespoke requirement please contact your local Valmont Stainton representative to discuss your specific needs.

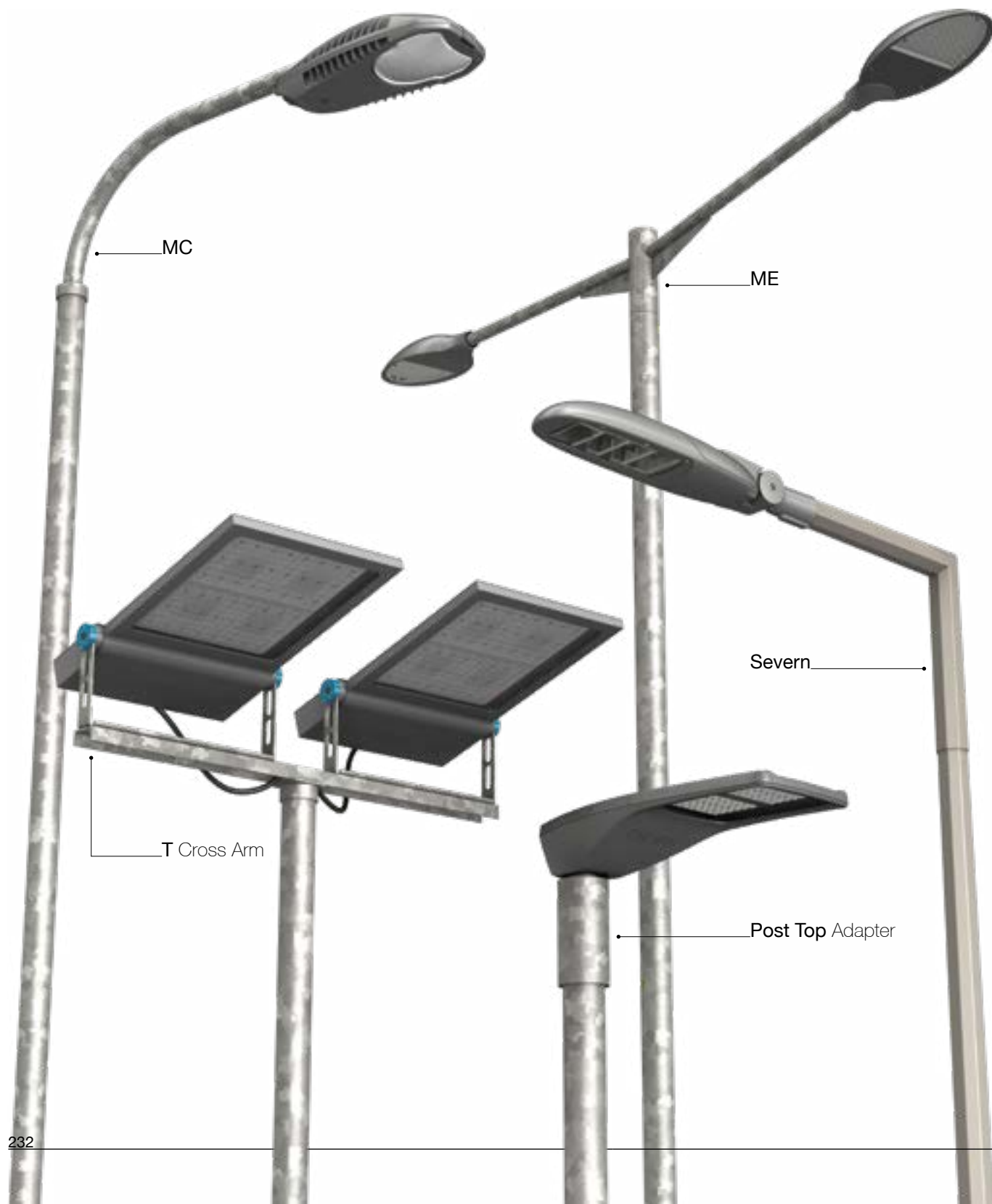

Post Top Adapters

Drop-over style bracket available in post top configuration for spigot entry sizes R60.3mm and R76.1mm. Ideally suited for stepped tubular columns where the bracket pot will fit flush with the shaft of the column. Also available in a retrofit drop over configuration.



Post Top Adapters

| Bracket Reference | Pot Ø / OD 1 (mm) | Spigot Ø / OD 2 (mm) | Pot Height / Y (mm) | Weight (kg) |
|-------------------|-------------------|----------------------|---------------------|-------------|
| PTA76/60 | 76,1 | 60,3 | 280 | 2,1 |
| PTA89/60 | 88,9 | 60,3 | 280 | 2,5 |
| PTA89/76 | 88,9 | 76,1 | 280 | 3,1 |
| PTA114/60 | 114,3 | 60,3 | 280 | 3,3 |
| PTA114/76 | 114,3 | 76,1 | 280 | 3,4 |
| PTA139/60 | 139,7 | 60,3 | 280 | 5,1 |
| PTA139/76 | 139,7 | 76,1 | 280 | 5,4 |
| PTA168/60 | 168,3 | 60,3 | 480 | 8,5 |
| PTA168/76 | 168,3 | 76,1 | 480 | 8,5 |

Dimensions and technical information given as an indication.

Valmont reserves the right to make, without delay and without prior notice, the technical or aesthetic modifications that it deems necessary to improve the products of the Standard Collection.

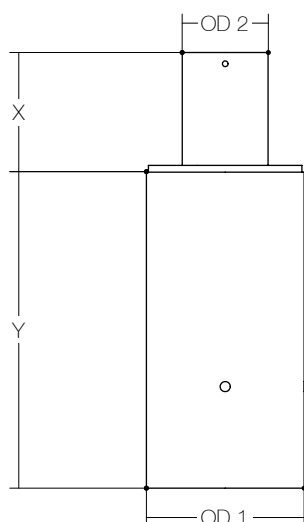

X = 100mm as standard.

Fixation:

1 x Row of 3 No. M10 grub screws + anti rotation dimple (up to Ø139.7)

2 x Rows of 4 No. M10 grub screws (Ø168.3)

Functional Lantern Brackets

ME Metro

Drop-over style bracket available in single-arm and double-arm configurations in projections from 0.3m to 2m. Ideally suited to stepped tubular columns where the bracket pot will fit flush with the shaft of the column.



ME Bracket Single and Double Arms

| Bracket Reference | Projection (mm) | Pot Ø / OD 1 (mm) | Bracket Ø / OD 2 (mm) | Spigot Ø / OD 3 (mm) | Single Arm Weight (kg) | Double Arm Weight (kg) |
|-------------------|-----------------|-------------------|-----------------------|----------------------|------------------------|------------------------|
| ME76/42 (S or D) | 300 | 76,1 | 42,4 | 42,4 | 3,0 | 4,4 |
| | 500 | 76,1 | 42,4 | 42,4 | 3,5 | 5,4 |
| | 1000 | 76,1 | 42,4 | 42,4 | 4,9 | 8,1 |
| | 1500 | 76,1 | 42,4 | 42,4 | 6,1 | 10,7 |
| ME89/42 (S or D) | 300 | 88,9 | 42,4 | 42,4 | 3,3 | 4,8 |
| | 500 | 88,9 | 42,4 | 42,4 | 3,8 | 5,7 |
| | 1000 | 88,9 | 42,4 | 42,4 | 5,2 | 8,4 |
| | 1500 | 88,9 | 42,4 | 42,4 | 6,4 | 11,0 |
| ME114/42 (S or D) | 300 | 114,3 | 42,4 | 42,4 | 3,9 | 5,3 |
| | 500 | 114,3 | 42,4 | 42,4 | 4,3 | 6,2 |
| | 1000 | 114,3 | 42,4 | 42,4 | 5,7 | 9,0 |
| | 1500 | 114,3 | 42,4 | 42,4 | 7,0 | 11,5 |
| ME139/42 (S or D) | 300 | 139,7 | 42,4 | 42,4 | 4,5 | 5,9 |
| | 500 | 139,7 | 42,4 | 42,4 | 5,0 | 6,9 |
| | 1000 | 139,7 | 42,4 | 42,4 | 6,3 | 9,6 |
| | 1500 | 139,7 | 42,4 | 42,4 | 7,6 | 12,1 |
| ME168/42 (S or D) | 300 | 168,3 | 42,4 | 42,4 | 6,3 | 7,7 |
| | 500 | 168,3 | 42,4 | 42,4 | 6,8 | 8,6 |
| | 1000 | 168,3 | 42,4 | 42,4 | 8,1 | 11,4 |
| | 1500 | 168,3 | 42,4 | 42,4 | 9,4 | 13,9 |

Dimensions and technical information given as an indication.

Valmont reserves the right to make, without delay and without prior notice, the technical or aesthetic modifications that it deems necessary to improve the products of the Standard Collection.

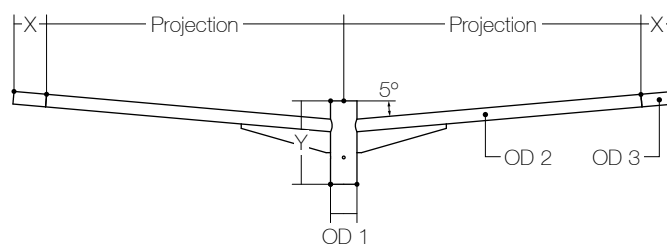
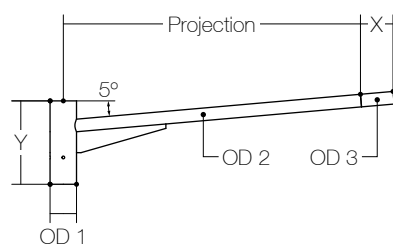

X = 100mm as standard.

Y = 280mm (up to Ø139,7) or 480mm (Ø168,3)

OD2 = Ø42,4mm as standard Ø60,3 also available.

Fixation:

1 x Row of 3 No. M10 grub screws + anti rotation dimple (up to Ø139.7)

2 x Rows of 3 No. M10 grub screws + anti rotation dimple (Ø168.3)

MD Ayr

Straight mitred bracket arm available in single and double arm configurations complete with internal fitting spigot for column connection. Available in varying projections and with additional rise to raise the height of the column to the required luminaire fitting height. Ideally suited to octagonal and conical columns.



MD Bracket Single and Double Arms

| Bracket Reference | Projection (mm) | Rise (mm) | Bracket Arm Ø / OD 1 (mm) | Spigot Ø / OD 2 (mm) | Single Arm Weight (kg) | Double Arm Weight (kg) |
|-----------------------|-----------------|-----------|---------------------------|----------------------|------------------------|------------------------|
| MD60/42-500 (S or D) | 500 | 2000 | 60,3 | 42,4 | 15,1 | 17,8 |
| | 500 | Nominal | 60,3 | 42,4 | 6,7 | 8,5 |
| MD60/42-1000 (S or D) | 1000 | 2000 | 60,3 | 42,4 | 17,3 | 22,5 |
| | 1000 | Nominal | 60,3 | 42,4 | 9,1 | 13,2 |
| MD60/42-1500 (S or D) | 1500 | 2000 | 60,3 | 42,4 | 19,7 | 27,1 |
| | 1500 | Nominal | 60,3 | 42,4 | 11,5 | 18,0 |
| MD60/42-2000 (S or D) | 2000 | 2000 | 60,3 | 42,4 | 21,7 | 31,8 |
| | 2000 | Nominal | 60,3 | 42,4 | 13,8 | 23,0 |
| MD60/42-2500 (S or D) | 2500 | 2000 | 60,3 | 42,4 | 23,9 | 36,4 |
| | 2500 | Nominal | 60,3 | 42,4 | 16,2 | 27,4 |

Stainless Steel MD Bracket Single and Double

| Bracket Reference | Projection (mm) | Rise (mm) | Bracket Arm Ø / OD 1 (mm) | Spigot Ø / OD 2 (mm) | Single Arm Weight (kg) | Double Arm Weight (kg) |
|-------------------------|-----------------|-----------|---------------------------|----------------------|------------------------|------------------------|
| SSMD60/42-500 (S or D) | 500 | Nominal | 60,3 | 42,16 | 5,0 | 7,2 |
| SSMD60/42-1000 (S or D) | 1000 | Nominal | 60,3 | 42,16 | 6,8 | 11,2 |
| SSMD60/42-1500 (S or D) | 1500 | Nominal | 60,3 | 42,16 | 11,8 | 20,6 |
| SSMD60/42-2000 (SA) | 2000 | Nominal | 60,3 | 42,16 | 15,0 | - |

Dimensions and technical information given as an indication.

Valmont reserves the right to make, without delay and without prior notice, the technical or aesthetic modifications that it deems necessary to improve the products of the Standard Collection.

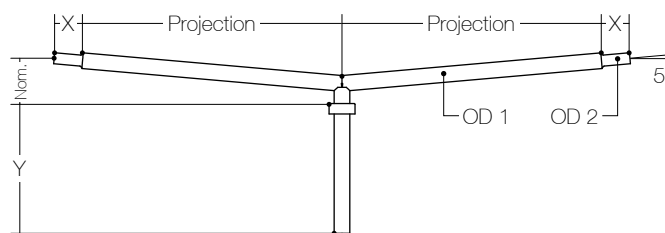
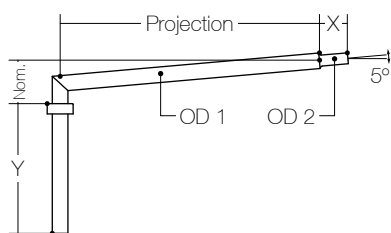
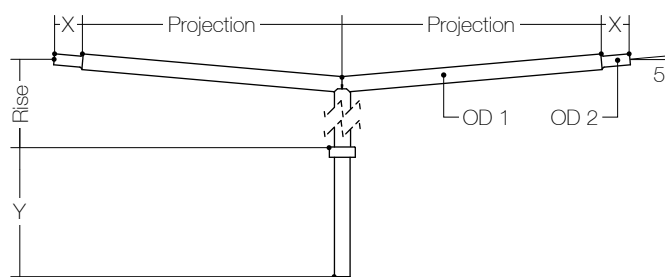
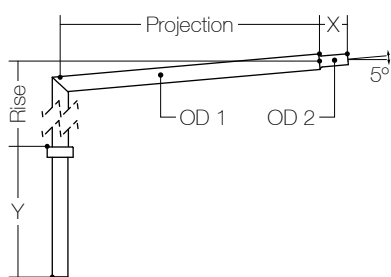

X = 100mm + as standard.

Y = 500mm as standard.

Functional Lantern Brackets

MC Thames

Curved bracket arm available in single and double arm configurations complete with internal fitting spigot for column connection. Available in varying projections and with additional rise to raise the height of the column to the required lantern fitting height. Ideally suited to octagonal and conical columns.



MC Thames Bracket Single Arm

| Bracket Reference | Projection (mm) | Rise (mm) | Bracket Arm Ø / OD 1 (mm) | Spigot Ø / OD 2 (mm) | Single Arm Weight (kg) |
|-------------------|-----------------|-----------|---------------------------|----------------------|------------------------|
| MC60/42-500 | 500 | 2000 | 60,3 | 42,4 | 14,4 |
| | 500 | Nominal | 60,3 | 42,4 | 7,3 |
| MC60/42-1000 | 1000 | 2000 | 60,3 | 42,4 | 16,6 |
| | 1000 | Nominal | 60,3 | 42,4 | 9,8 |
| MC60/42-1500 | 1500 | 2000 | 60,3 | 42,4 | 18,8 |
| | 1500 | Nominal | 60,3 | 42,4 | 12,2 |
| MC60/42-2000 | 2000 | 2000 | 60,3 | 42,4 | 21,0 |
| | 2000 | Nominal | 60,3 | 42,4 | 14,6 |
| MC60/42-2500 | 2500 | 2000 | 60,3 | 42,4 | 23,2 |
| | 2500 | Nominal | 60,3 | 42,4 | 17,0 |

Stainless Steel MC Thames Bracket Single Arm

| Bracket Reference | Projection (mm) | Rise (mm) | Bracket Arm Ø / OD 1 (mm) | Spigot Ø / OD 2 (mm) | Single Arm Weight (kg) |
|-------------------|-----------------|-----------|---------------------------|----------------------|------------------------|
| SSMC60/42-500 | 500 | Nominal | 60,3 | 42,16 | 6 |
| SSMC60/42-1000 | 1000 | Nominal | 60,3 | 42,16 | 8 |
| SSMC60/42-1500 | 1500 | Nominal | 60,3 | 42,16 | 10 |

Dimensions and technical information given as an indication.

Valmont reserves the right to make, without delay and without prior notice, the technical or aesthetic modifications that it deems necessary to improve the products of the Standard Collection.

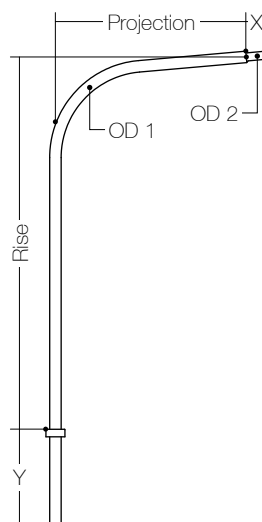
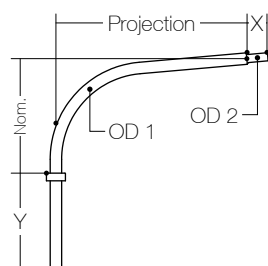

X = 100mm + as standard.

Y = 500mm as standard.

Severn Bracket

Straight mitred Stainless bracket arm available in single and double arm configurations complete with drop over fitting arrangement for column connection. Available in varying projections and with additional rise to raise the height of the column to the required luminaire fitting height. Ideally suited to Stainless octagonal and conical columns.



Severn Bracket Single Arm

| Bracket Reference | Projection (mm) | Across Flats Bottom / AF 1 (mm) | Across Flats Top / AF 2 (mm) | Spigot Ø / OD 1 (mm) | Weight (kg) |
|-------------------|-----------------|---------------------------------|------------------------------|----------------------|-------------|
| SEV79/69-300 | 300 | 79 | 69 | 33,7 | 2,7 |
| SEV79/69-500 | 500 | 79 | 69 | 33,7 | 3,4 |
| SEV79/69-750 | 750 | 79 | 69 | 33,7 | 3,4 |
| SEV79/69-800 | 800 | 79 | 69 | 33,7 | 4,3 |

Dimensions and technical information given as an indication.

Valmont reserves the right to make, without delay and without prior notice, the technical or aesthetic modifications that it deems necessary to improve the products of the Standard Collection.

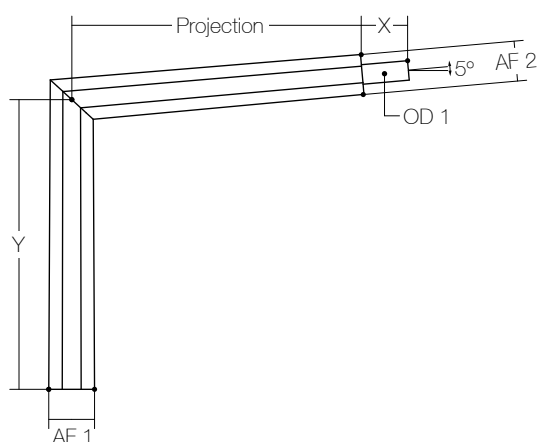

X = 80mm + as standard.

Y = 500mm as standard.

Functional Lantern Brackets

“T” Cross Arm

The “T” Cross-arm bracket range includes varying sizes and configurations to suit any given floodlighting arrangement. Column connection with regards to the “T” Cross-Arm is via an internal spigot. The “T” range cross arms are ideally suited to the Valmont Stainton Octagonal, Derwent and Humber range.



T Cross Arm

| Bracket Reference | Width (mm) | Depth (mm) | Pot Ø / OD 1 (mm) | X (mm) | Y (mm) | z (mm) | Weight (kg) |
|-------------------|------------|------------|-------------------|--------|--------|--------|-------------|
| T Cross Arm | 1100 | 76 | 60,3 | 385 | 165 | 500 | 10,9 |

Dimensions and technical information given as an indication.

Valmont reserves the right to make, without delay and without prior notice, the technical or aesthetic modifications that it deems necessary to improve the products of the Standard Collection.

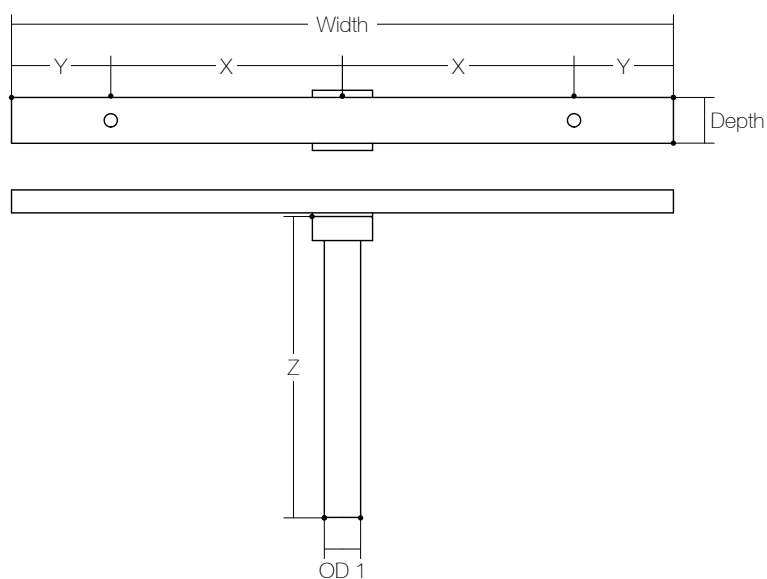

Floodlight Brackets

Cross-arm brackets are available in varying sizes and configurations to suit any given floodlighting arrangement. Column connections to suit application with drop-over style pots, internal spigots or flange-plated connections available. Bracket cross arms are ideally suited to the Valmont Stainton Octagonal, Derwent and Humber ranges.



Floodlight Brackets

| Bracket Reference | Width (mm) | Depth (mm) | Pot Ø / OD 1 (mm) | X (mm) | Y (mm) | Pot Height / Z (mm) | Weight (kg) |
|---------------------|------------|------------|-------------------|--------|--------|---------------------|-------------|
| Up to 2 Floodlights | 1400 | 76 | 88,9 | 355 | - | 495 | 12,5 |
| | 1600 | 50 | 139,7 | 500 | - | 390 | 30 |
| Up to 3 Floodlights | 2100 | 76 | 88,9 | 700 | - | 495 | 26 |
| | 2200 | 100 | 139,7 | 900 | - | 390 | 47 |
| Up to 5 Floodlights | 2200 | 100 | 168,3 | 900 | - | 390 | 50 |
| | 3200 | 100 | 139,7 | 600 | 800 | 390 | 66 |
| Up to 8 Floodlights | 3200 | 100 | 168,3 | 600 | 800 | 390 | 68 |

Dimensions and technical information given as an indication.

Valmont reserves the right to make, without delay and without prior notice, the technical or aesthetic modifications that it deems necessary to improve the products of the Standard Collection.

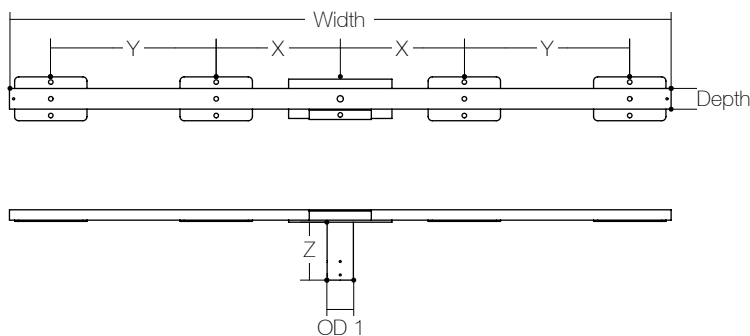

Fixation:
2 x Rows of 4 No. M12 grub screws

Functional Lantern Brackets

Cow Horn

Drop-over style bracket available in double-arm configurations in projections from 0.3m to 2m. Ideally suited for dual post top fitting to stepped tubular columns where the bracket pot will fit flush with the shaft of the column.



Cow Horn Bracket Double Arm

| Bracket Reference | Projection (mm) | Pot Ø / OD 1 (mm) | Spigot Ø / OD 2 (mm) | Bracket Arm Ø / OD 3 (mm) | Twin Arm Weight (kg) |
|-------------------|-----------------|-------------------|----------------------|---------------------------|----------------------|
| CH89/76-300 | 300 | 88,9 | 76,1 | 42,4 | 5,5 |
| CH89/76-500 | 500 | 88,9 | 76,1 | 42,4 | 8,1 |
| CH114/76-300 | 300 | 114,3 | 76,1 | 42,4 | 6,5 |
| CH114/76-500 | 500 | 114,3 | 76,1 | 42,4 | 7,5 |
| CH139/76-300 | 300 | 139,7 | 76,1 | 42,4 | 6,9 |
| CH139/76-500 | 500 | 139,7 | 76,1 | 42,4 | 8,1 |

Dimensions and technical information given as an indication.

Valmont reserves the right to make, without delay and without prior notice, the technical or aesthetic modifications that it deems necessary to improve the products of the Standard Collection.

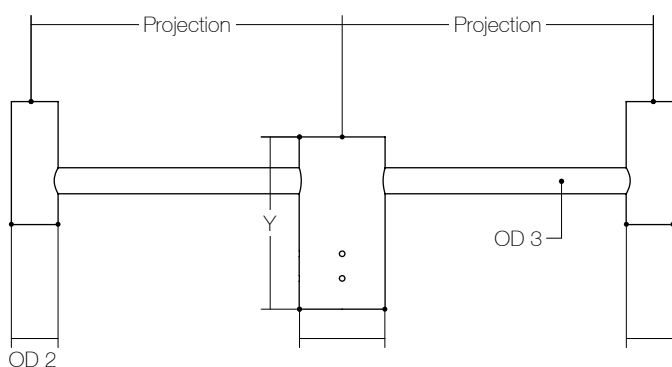

Y = 280mm

OD2 = Ø76,1mm as standard Ø60,3 also available.

Fixation:

1 x Row of 3 No. M10 grub screws + anti rotation dimple (up to Ø114,3)

2 x Rows of 3 No. M10 grub screws + anti rotation dimple (up to Ø139,7)

Post Top Extensions

Our post top extension bracket range facilitate the increase in mounting height of both new and existing lighting columns. Column connection with regards to the Post top extension range is via an internal spigot. The Post top extension range is ideally suited to the Valmont Stainton Octagonal, Conical and Tubular ranges.



Post Top Extensions

| Bracket Reference | Rise (mm) | Spigot Ø OD 1 (mm) | Extension Ø OD 2 (mm) | Weight (kg) |
|-------------------|-----------|--------------------|-----------------------|-------------|
| PTE110/60 | 110 | 60 | 60 | 3,5 |
| PTE500/60 | 500 | 60 | 60 | 5,3 |
| PTE1000/60 | 1000 | 60 | 60 | 7,7 |
| PTE2000/60 | 2000 | 60 | 60 | 10,0 |
| PTE110/76 | 110 | 60 | 76 | 3,5 |
| PTE600/76 | 500 | 60 | 76 | 6,2 |
| PTE1000/76 | 1000 | 60 | 76 | 8,2 |
| PTE2000/76 | 2000 | 60 | 76 | 15,5 |

Dimensions and technical information given as an indication.

Valmont reserves the right to make, without delay and without prior notice, the technical or aesthetic modifications that it deems necessary to improve the products of the Standard Collection.

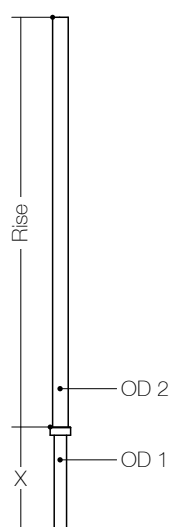

X = 500mm as standard.

Decorative Lantern Brackets Steel

Steel Brackets

Opting for a decorative bracket on your next project is a simple way to personalize your lighting column. Valmont Stainton steel brackets are designed to complement a wide range of columns and lanterns.

Brackets are available in both single and double arm options. For information concerning dimensions and capacities please contact your local Valmont Stainton representative.

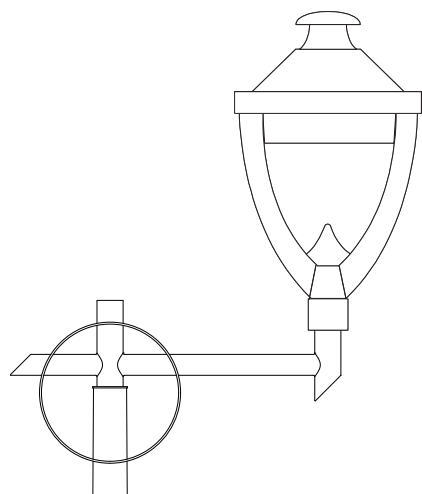

Gannet

Bracket for post top lanterns. Single and double arm options for this bracket available.

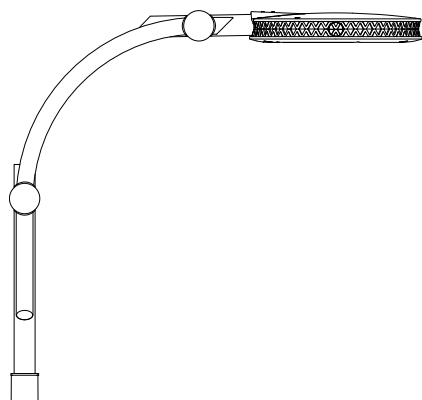

Copse

Bracket for lateral mounting. Single and double arm options for this bracket available.

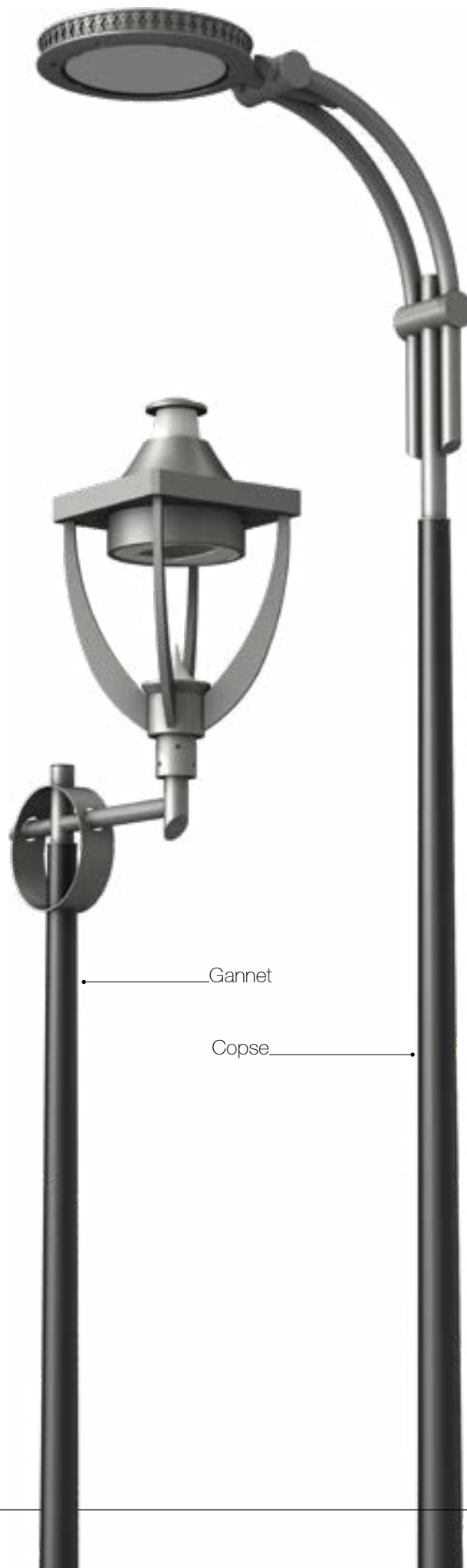

Gannet

Copse

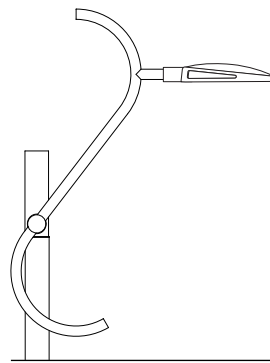

Emma

Bracket for lateral mounting. Single and double arm options for this bracket available.

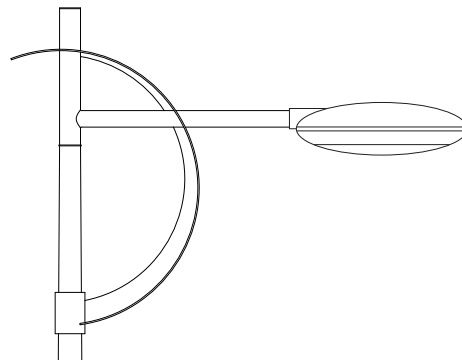

Centimo

Bracket for lateral mounting. Single and double arm options for this bracket are available.

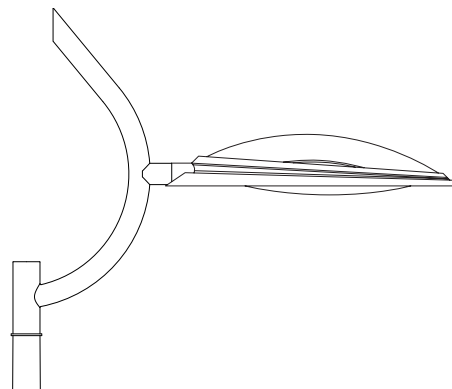

Tulip

Bracket for lateral mounting. Single and double arm options for this bracket available.

Decorative Lantern Brackets Aluminium

Aluminium Brackets

Valmont offers an extensive collection of cast aluminium brackets. The aluminium casting process allows for great design flexibility and precision.

Brackets are available in single and double arm options at various projection lengths. For information concerning dimensions and capacities please contact your local Valmont Stainton representative.

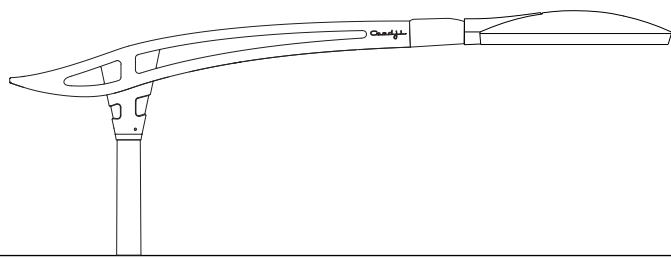

Ceedji

Bracket for lateral mounting. Single arm, double arm, and wall mount options are available.

Projections: .8m & 1.2m

This bracket is designed according to standard EN40 part 1 to 6 and has obtained CE marking 1166-CPD-0006.

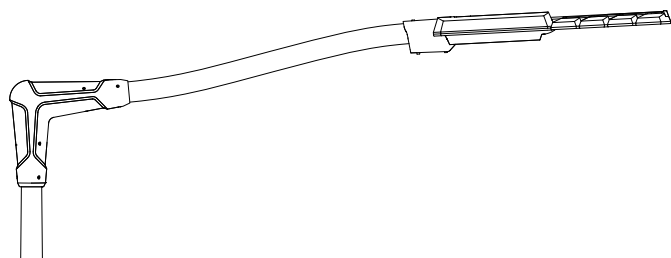

Remo

Bracket for lateral mounting. Single arm and double arm options are available with straight or double curved arms.

Projections: .75 m & 1.2m

This bracket is designed according to standard EN40 part 1 to 6 and has obtained CE marking 1166-CPD-0006.





Linéa

Bracket for lateral mounting. Single arm, double arm, post-top, and wall mount options are available.

Projections: .4m & 1.2m

This bracket is designed according to standard EN40 part 1 to 6 and has obtained CE marking 1166-CPD-0006.

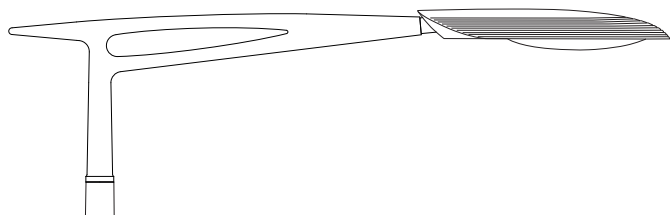

Annapurna

Bracket for lateral mounting. Single arm, double arm, and wall mounted options are available.

Projections: .4m & 1.2m

This bracket is designed according to standard EN40 part 1 to 6 and has obtained CE marking 1166-CPD-0006.



Decorative Lantern Brackets Aluminium

Illuminated Brackets

A small detail with a powerful impact. Valmont Stainton offers a selection of lantern brackets with an integrated LED accent. In combination, these sculpted brackets and the internal accent lights create a strong visual presence both day and night.

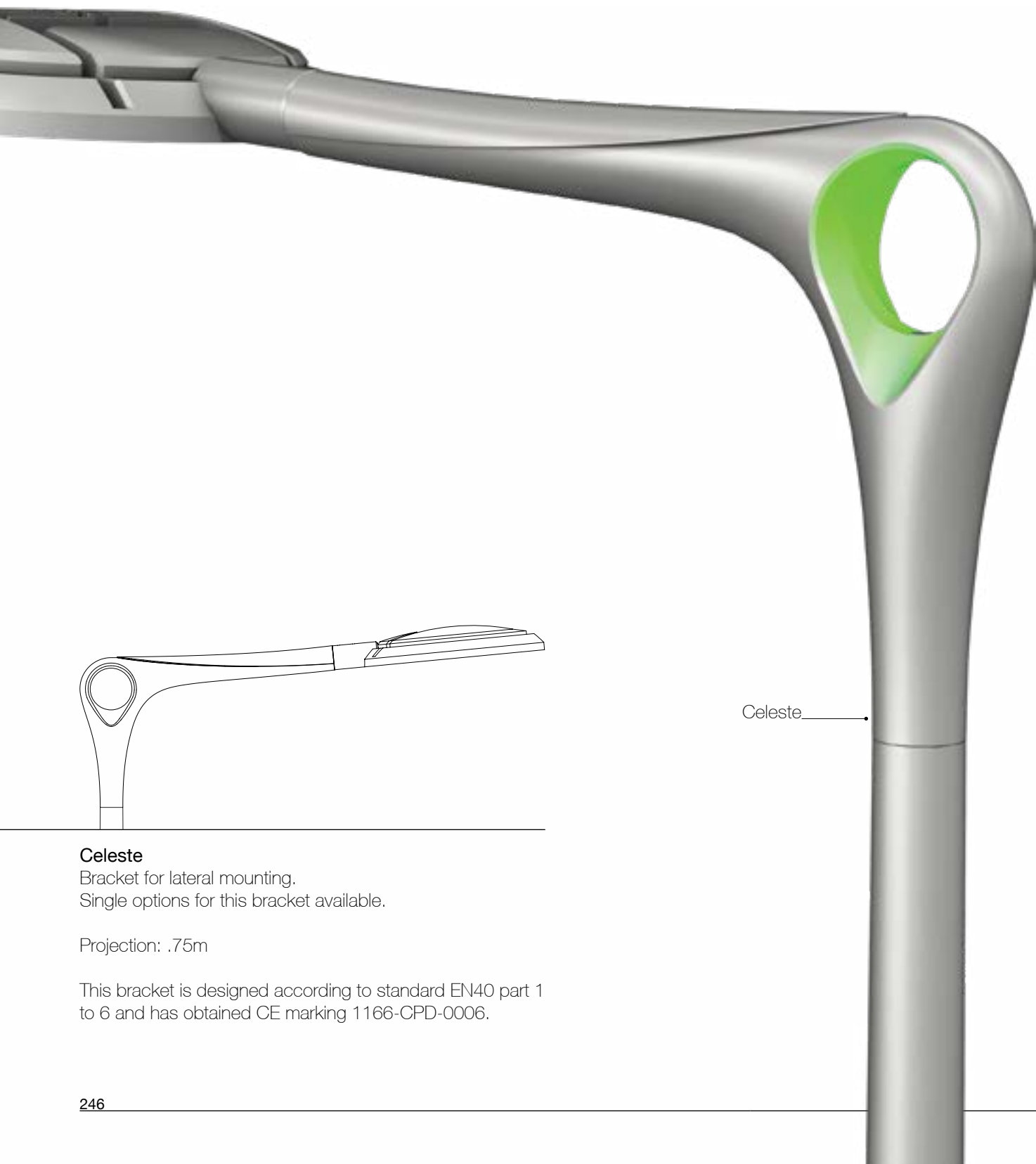

Celeste

Celeste

Bracket for lateral mounting.
Single options for this bracket available.

Projection: .75m

This bracket is designed according to standard EN40 part 1 to 6 and has obtained CE marking 1166-CPD-0006.

Accent LED

LED accent lighting can be integrated into a selection of Valmont brackets.

Constructed from machined aluminium Ø23mm
Red, Green, Blue or RGBW available.

IP67 rating, operating temperature -25° ~ +50°



ZAHA

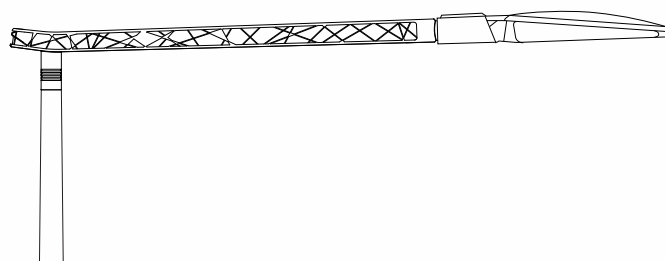

ZAHA

Bracket for lateral mounting. Single arm, double arm, and wall mount options are available.

Projections: .4m & 1.2m

This bracket is designed according to standard EN40 part 1 to 6 and has obtained CE marking 1166-CPD-0006.

Decorative Lantern Brackets Wood Specific

Wood Specific Brackets

Valmont Wood Specific Brackets may not be manufactured from wood, but they are designed with our wooden columns in mind.

Wood Specific Brackets are available in single and double configurations at various lengths. For more information concerning dimensions and capacities please contact your local Valmont representative.

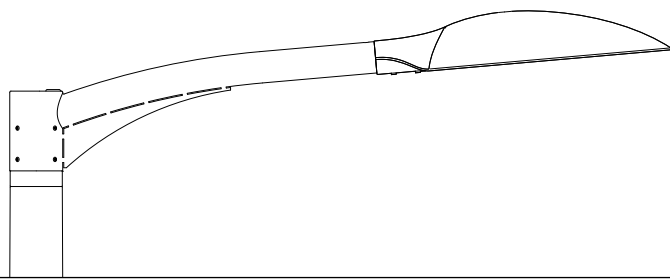

Merganser

A timeless design constructed from round tube and plate steel. Suitable for post top installation.

Merganser is available in both single arm and double arm options and can be used on both square and round columns.

This bracket is designed according to standard EN40 part 1 to 6 and has obtained CE marking 1166-CPD-0006.

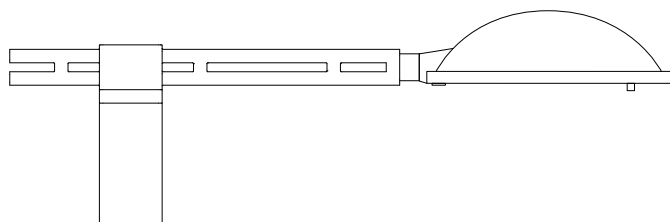

Tikka

A simple lattice bar construction designed for post top installation on a range of wooden columns.

Tikka is available in both single arm and double arm options and can be used on both square and round columns.

This bracket is designed according to standard EN40 part 1 to 6 and has obtained CE marking 1166-CPD-0006.



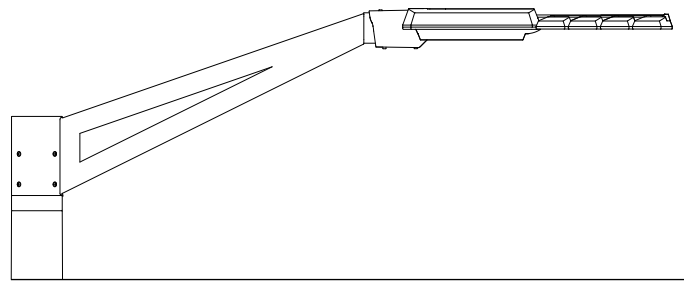
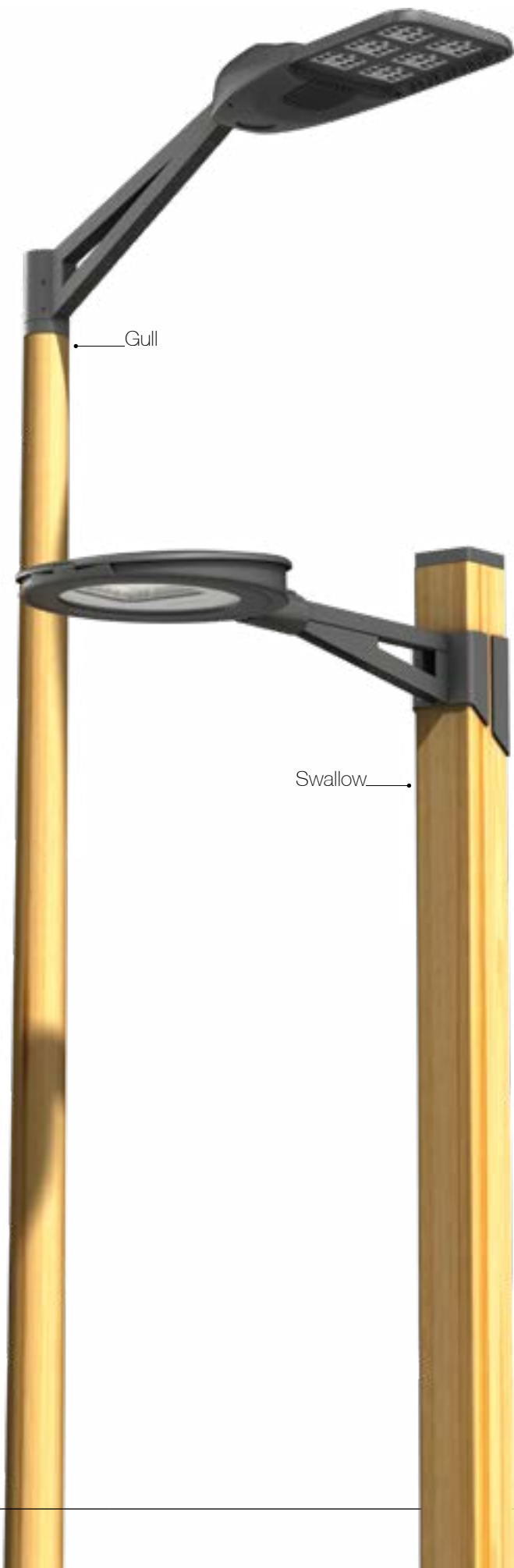

Gull

A familiar form constructed from square tube and designed for post top installation.

Gull is available in both single arm and double arm options and can be used on both square and round columns.

This bracket is designed according to standard EN40 part 1 to 6 and has obtained CE marking 1166-CPD-0006.

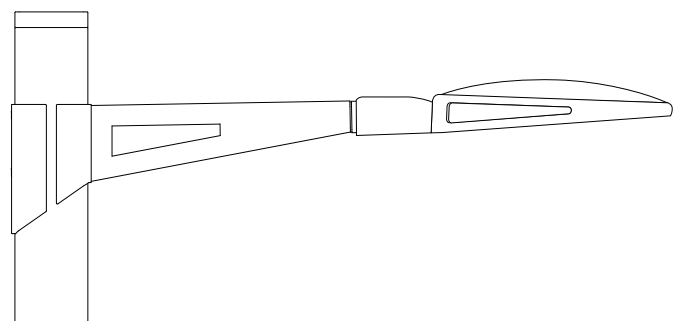

Swallow

A bracket constructed from square tube and designed to be installed on the column shaft.

Swallow is available in both single arm and double arm options and can be used on both square and round columns.

This bracket is designed according to standard EN40 part 1 to 6 and has obtained CE marking 1166-CPD-0006.

Accent Lighting O'light and iLed

Ô'light²

The Ô'light² can be used for accenting a design, or highlighting certain area's and routes.

White polyethylene system, Ø60 or 76mm, 1W White, Blue, Red or Green LED included. IP66 - Class II - IK10 - 220V - 50Hz.

The Ô'light² can be used in combination with Ø60 or 76mm shaft in steel or aluminium.

Length: 300 & 600mm.

H07RNF 2G1, 5mm² cable, length 10.5m.

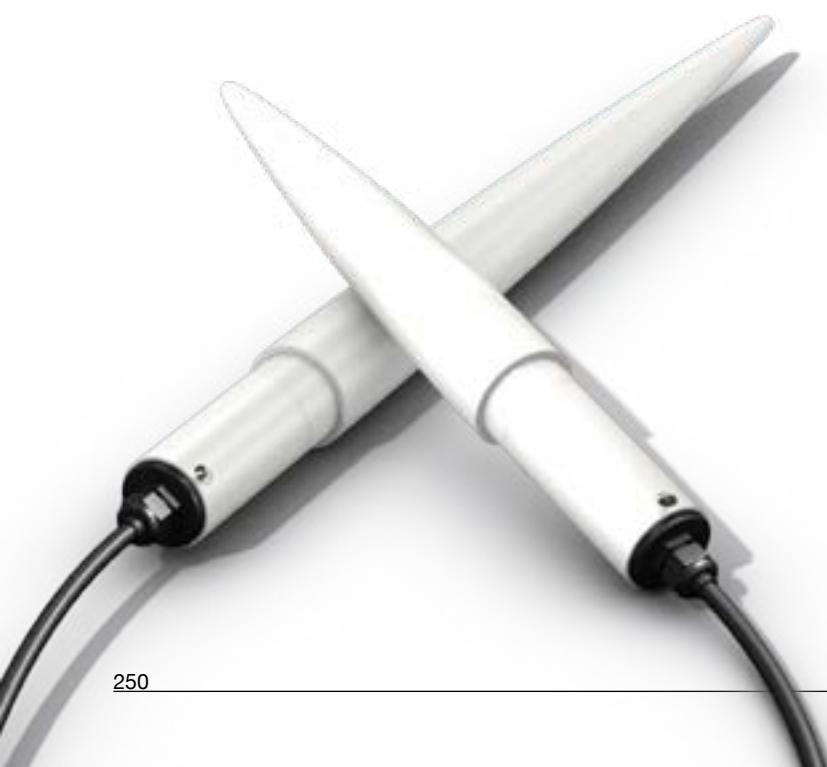
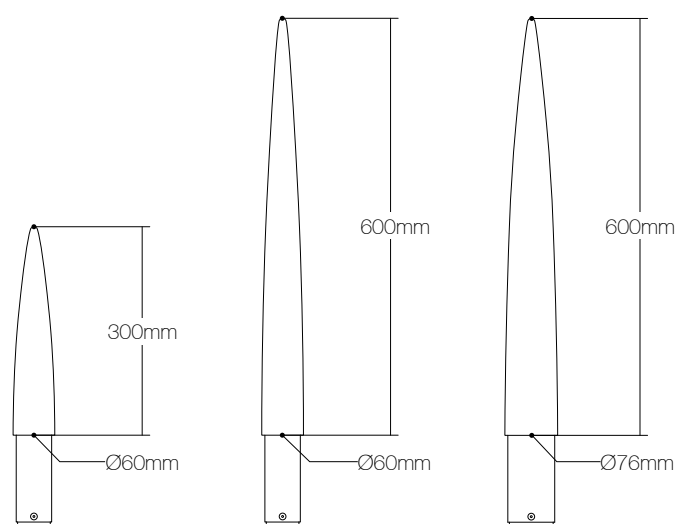



iLed²

The iLed² is a small marker light that can be installed as an optional accessory.

Constructed from machined aluminium Ø15,7mm.
Blue, White, Amber, Red, and Green LED's are available.

The iLed² is IP67 certified.
Recessed fitting integrated in the column, all wiring carried out in the factory.

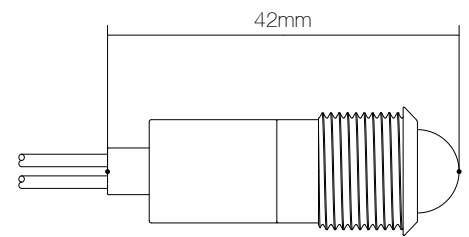
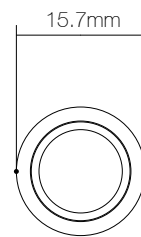

High Mast Accessories Brackets & Access

Floodlighting Cross-Arm Arrangements.

From industry standard bolt on Cross-Arms to full array headframe systems, whatever your area lighting scheme needs, Valmont Stainton's range of floodlight attachment systems has something to cater for your application requirements.

In addition to floodlight brackets Valmont also offers an assortment of accessories designed to maximise the functionality and accessibility of your high mast.

Whether it's a demountable climbing access system, safety harness or simply a pole cap, Valmont Stainton has the high mast accessory products to suit your application.



Access.

Valmont highmast structures can be fitted with service platforms that make working at height safe and convenient.

Valmont service platforms are equipped with a trapdoor system that makes entrance possible via climbing rungs and safety cable. The trapdoor is limited to an opening of 85°. This feature causes the door to close automatically, thus limiting the potential for accidents.

Unibody construction is easily installed by two M16 callipers.

Complies with NF EN ISO 14122-2 standards and 14122-3.

Climbing rungs utilize an anti-slip surface which provides a solid contact surface for both foot and hand.

Resistance greater than 260 daN.

Multiple options are available to suit a wide range of needs. Please contact your Valmont representative for additional information on these products.



Automated Lift.

Valmont high mast structures can be fitted with an automated lift system that is safe, practical, and removable. The lift ascends the mast via an electric winch and steel safety cables. The lift is capable of transporting two maintenance technicians and their equipment to the top of a 70m structure and safely back down again.

Technical Data

Empty weight: 183 kg.

Load capacity: 300 kg max.

Maximum height of use: 70 m.

Maximum wind speed: 35 km / h. Use in clear weather.

EC type examination certificate: No. 0398 / 76S / 636/03/00.



Finishes

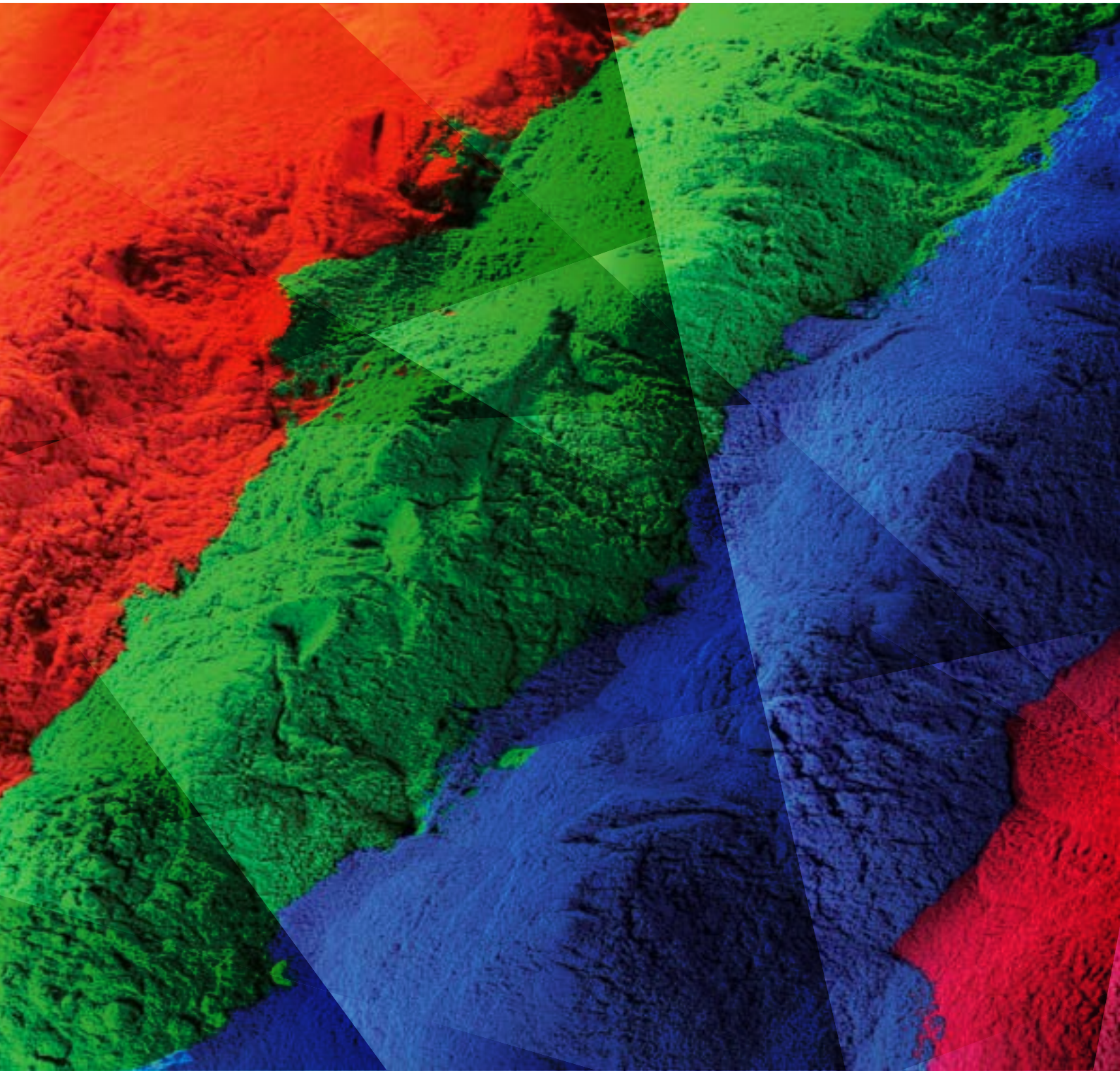

- Powder Coating
- Aluminium Finishes
- Wood Finishes
- RAL Colours
- Sublimation
- Speciality Finishes
- Paint Finishes
- Root Protection

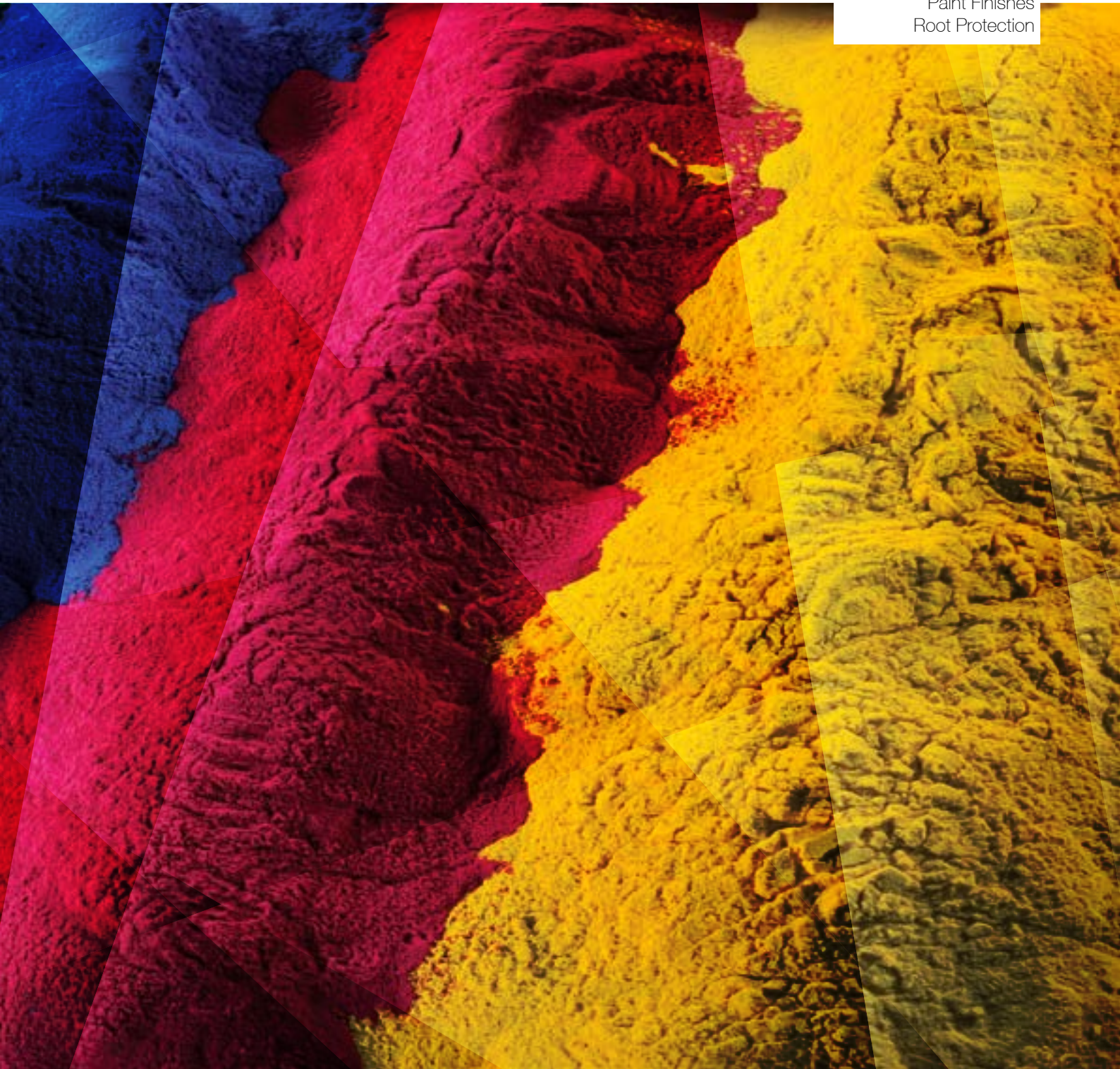

Powder Coating

Standard Processes and Finishes

Baked On Protection...

The powder coating process involves applying finely ground polymer resin powder to a metallic surface and then curing it with the addition of heat in precisely controlled ovens.

The addition of heat chemically changes the powder into a remarkably long lasting and robust finish which will stand up to impressive amounts of abuse, year after year.

Powder coated finishes are available in a wide array of colours and textures and can be applied to both steel and aluminium surfaces.



Canyon...

Canyon is a range of colours which are found in arid environments all over the world. These tones and shades can help create a warm, contemporary atmosphere within your towns...



Canyon 01



Canyon 02



Canyon 03



Canyon 04



Canyon 05

Tundra...

Tundra is a range of colours with a mineral and sandy appearance. This pallet easily blends into urban backgrounds and helps your project achieve graphic uniformity...



Tundra 01



Tundra 02



Tundra 03



Tundra 04

Disclaimer: Due to printing techniques, the colours presented may differ slightly from reality.

Jungle...

Jungle is a range of colours in plant-inspired shades. These tones can be used to help structures blend into a green space or to bring a touch of nature to your urban environment...

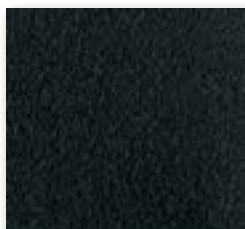

Jungle 01

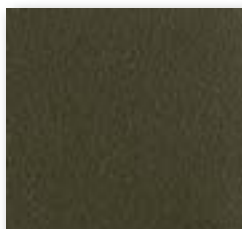

Jungle 02



Jungle 03

Fjord...

Fjord is a range of colours with ocean shades like those of the glacier carved Scandinavian inlets. These blue-grey tones will bring a certain urban freshness to your productions...



Fjord 01



Fjord 02



Fjord 03



Fjord 04



Fjord 05

City...

City is a range of metallic shades which blend perfectly with urban spaces. These industrial tones can bring a quiet sophistication to the products on which they are applied...



City 01



City 02



City 03



City 04



City 05

Disclaimer: Due to printing techniques, the colours presented may differ slightly from reality.

Aluminium Finishes

Standard Processes and Finishes

Anodising...

Anodising is a surface treatment operation used to protect and decorate a piece of Aluminium using anodic oxidation.

Anodic oxidation is an electrochemical process which transforms the artificial layer into a 15-25 micron layer of oxide. This process is obtained by successive dips, mainly in sulphuric acid.

Designed to provide aluminium with optimum protection, anodising gives aluminium an aesthetically pleasing appearance and a surface which refuses to age, even in challenging environments.



Traditional...

A selection of four traditionally-used colours.

These shades help our Aluminium products maintain their visual appeal in the long term.



Colourless CS01



Light Bronze CS10



Dark Bronze CS11



Black CS12



Quality Label

Disclaimer: Due to printing techniques, the colours presented may differ slightly from reality.

Spectro-Colouring...

Spectro-colouring is a surface treatment operation used to apply colour an anodised piece of Aluminium.

Spectro-colouring is a process which combines chemical and electric parametres to form a superficial layer of alumina with controlled dimensions, spread and direction. The result is a highly durable and colour stable finish.

Spectro-colouring gives the aluminium colour without taking away the material's aesthetic characteristics. Colour is added, but look and feel of brushed aluminium remain...



Spectral...

Selected for their interaction with natural light...

These subtle tones can help create an unexpectedly soft, metallic atmosphere.



Light Bronze 4

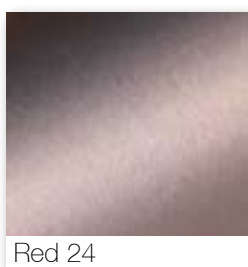

Red 24



Blue 14

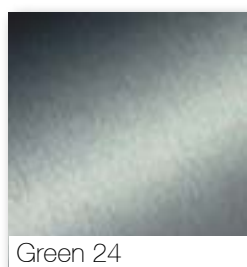

Green 24

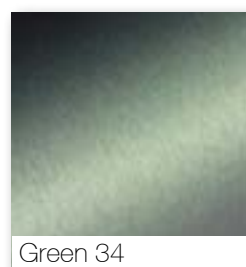

Green 34

Disclaimer: Due to printing techniques, the colours presented may differ slightly from reality.

Wood Finishes

Standard Processes and Finishes

Enhancing Natural Beauty...

Our surface treatments have been designed to deliver the ultimate combination of environmental friendliness and wood protection to obtain maximum product life cycle.

Wood is a natural material and it is expected to expand and contract as the seasons and moisture change. Our elastic coating is designed to expand and contract with the wood without cracking.



Nature Inspired...

A selection of pleasant colours borrowed from nature to help our columns integrate into a wide range of environments whilst enhancing the natural beauty of the material...

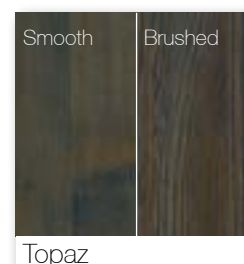
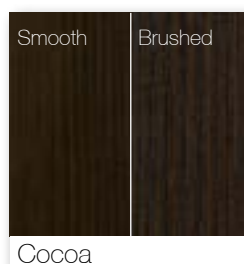
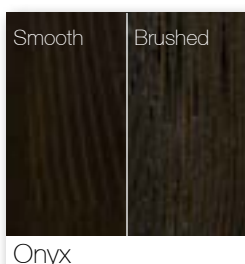
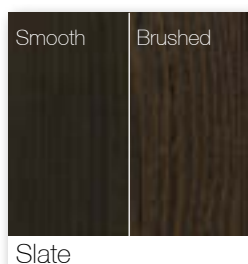
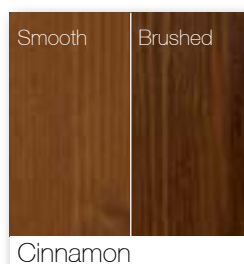
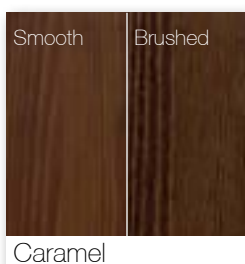
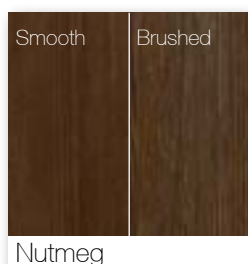
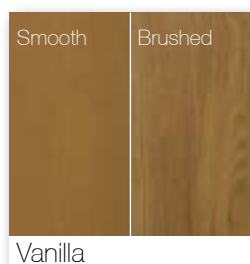

Note: All colours are available in both smooth and brushed finishes(on request) to highlight the natural grain of the wood.

Disclaimer: Due to printing techniques, the colours presented may differ slightly from reality.

Designed For Durability...

Our Tehocoat® coating system ensures a high quality, durable finish for your lighting columns.

Powder coating is a fast, durable and environmentally friendly solution. Coating powders contain no volatile organic compounds and can be used to obtain a durable surface resistant to mechanical and chemical abrasion.

In addition to powder coating, our finishing shop can also apply wet paints and Plascoat thermoplastic coatings, and utilize modern solutions to produce different kinds of textures.



A Perfect Match...

A small selection of colours for use with our galvanised bases, chosen for their compatibility with our standard wooden finishes...



Silver Grey



Toundra 03

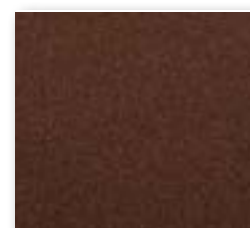

Mars



Dark Bronze

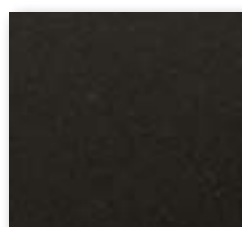

Grey 900 Sand

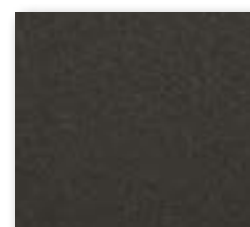

Graphite Grey

Disclaimer: Due to printing techniques, the colours presented may differ slightly from reality.

RAL Colours

Standard Processes and Finishes

Colour Standardised ...

RAL has represented the absolute standard for nine decades and is one of the world's oldest labelling systems.

The particularly high quality standards for products and services are developed by independent experts, subjected to continuous monitoring by independent institutions and constantly updated.



Trusted Quality...

RAL Quality Marks are trusted around the world, because they are reliable, objective and the regulations are always completely up-to-date.



RAL 5010



RAL 5020



RAL 5011



RAL 6005



RAL 6020



RAL 6009



RAL 3000



RAL 3004

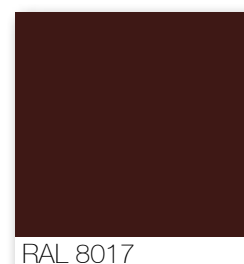

RAL 8017

Disclaimer: Due to printing techniques, the colours presented may differ slightly from reality.



The Finish You Need...

Valmont Stainton is able to offer RAL conformity with both powder and wet coating systems.

No matter what specifications you require for your finish, you can rest assured that the colour delivered will be exactly as ordered.

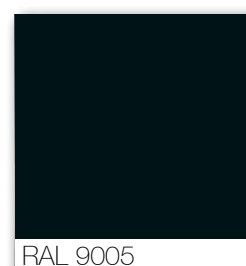
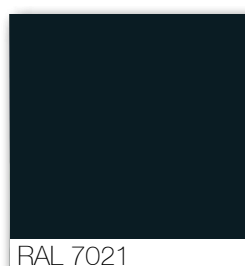
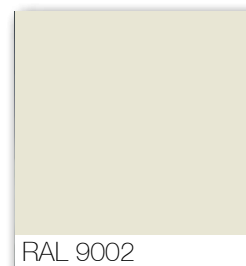
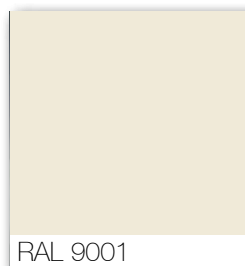
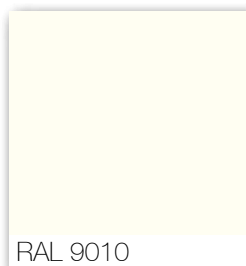

Disclaimer: Due to printing techniques, the colours presented may differ slightly from reality.

Sublimation Processes and Possibilities

The Possibilities Are Endless...

Transfer using sublimation is a simple and efficient process to apply high-quality images or graphics to a large variety of metallic surfaces and objects.

This industrial procedure consists of applying a polymerising polyester powder by electrostatic effect in a furnace. Then, under vacuum, a transfer film is applied with a previously agreed graphic design.

Transfer by sublimation then happens when it is cured in a furnace at a high temperature.

***Sublimation can be used on both steel and aluminium columns with a maximum linear length of 7 metres.



Animal...



Natural...



Industrial...



Mineral...

Create
your visual
Identity
...



Geometric...



Ornamental...

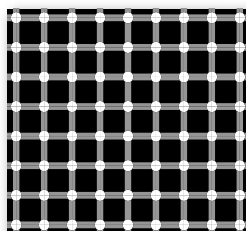

Hypnotic...



Gradients...

Create
your graphic
Identity
...

Disclaimer: Due to printing techniques, the colours presented may differ slightly from reality.



Disclaimer: Due to printing techniques, the colours presented may differ slightly from reality.

Speciality Finishes

One Rule Does Not Fit All...

Due to the wide range of environmental conditions, or bespoke aesthetic requests standard finish ranges do not always fit the bill,

At Valmont we constantly develop and bring to market new and improved corrosion protection systems, whether it be semi sheen product for architectural markets or extremely robust anti corrosion systems for coastal areas.

Whatever your requirement Valmont Stainton will have a solution, If don't see what you need, just ask.



Marine Environment Finish.

A highly durable finish applied to galvanised columns to be located in or near marine (saline and corrosive) atmospheric conditions. System type: spray paint 2-pack glass reinforced epoxy finish is applied to the column, then followed by a polysiloxane finish to RAL, BS4800 or BS381C colours.

Required durability of system: No maintenance in first 10 years, minor maintenance between years 10 to 25, major maintenance after 25 years.

Polyester Powder Coat.

To form a polyester powder coating, only the paint solids are sprayed onto the product, in an atomised powder form. The powder is drawn to the product and adheres due to an electrostatic charge applied to the powder during spraying. The column is then heated to 200 degrees Celsius in an oven, forcing the powder to fuse to the product, forming a smooth, tough and resilient coating. This provides an even and durable finish over the galvanised steel surface. XXXX denotes customer RAL choice.

Required durability of system: Long life system with excellent weather-proof characteristics. Damaged areas cannot, however, be repaired due to the nature of the coating.

Glass Flake Root System.

A highly durable finish applied to galvanised column root. This system uses 2-pack glass reinforced epoxy giving excellent abrasion, saline and corrosive resistance.

Both external root only, and internal/external root options are available upon request.

Bitumen Root.

Black bitumen coating is applied to the external root of the column, to a height of 250mm above ground level (unless otherwise specified).

Benefits: Additional protection of the root against corrosion.



Anti-graffiti / Anti-fly Poster Coating.

This anti-graffiti non stick surface coating, when combined with a suitable cleaning technology, allows the removal of graffiti without altering the original surface finish. Applied as an integral part of a polysiloxane system to the section of the column most prone to Graffiti and Fly posters. The area of the column with this coating has a textured surface. The system is highly resistant to many different kinds of marker pens and aerosols, as well as providing a non-stick surface to deter fly posters, and offers a hard wearing surface finish.

Required durability of system: Long term life of 25-30 years. Available in RAL, BS4800 or BS381C colours.

G1 Root System.

A Highways England series 1900: 2014 specification, 2 pack epoxy m.i.o, applied to the external root section and returned internally around edges. A 3-coat (including mordant T-wash on galvanised surface), 275 micron dry film thickness painted root.

Required durability of system: No maintenance in first 8 years, minor maintenance from 8 years and major maintenance after 15 years.

G2a and G2b Root System.

A Highways England series 1900: 2014 specification 4 and 5-coat systems, using 2 pack epoxy m.i.o, applied to the external root and upper sections including factory or site application of the finish coat.

Required durability of system: No maintenance in first 8 years, minor maintenance from 8 years and major maintenance after 15 years.

For more information on these specially finishes please contact your Valmont Stainton representative...



Projects
Certifications
Installation Foundations
Terms and Conditions
Dimensional Key
General Recommendations
Index
Credits



Bournemouth United Kingdom



Description:

7m and 25m wooden columns.
GL28h glued-laminated timber, PEFC certified.

Columns are fitted with illuminated finials, multiple lanterns and projectors.



Pier Approach Revitalized...

For this popular seaside attraction, Valmont crafted sleek, bespoke wood lighting columns and high masts. The columns were specially designed to support multiple light fittings at varying heights. A modern network displays interactive lighting to the delight of visitors.

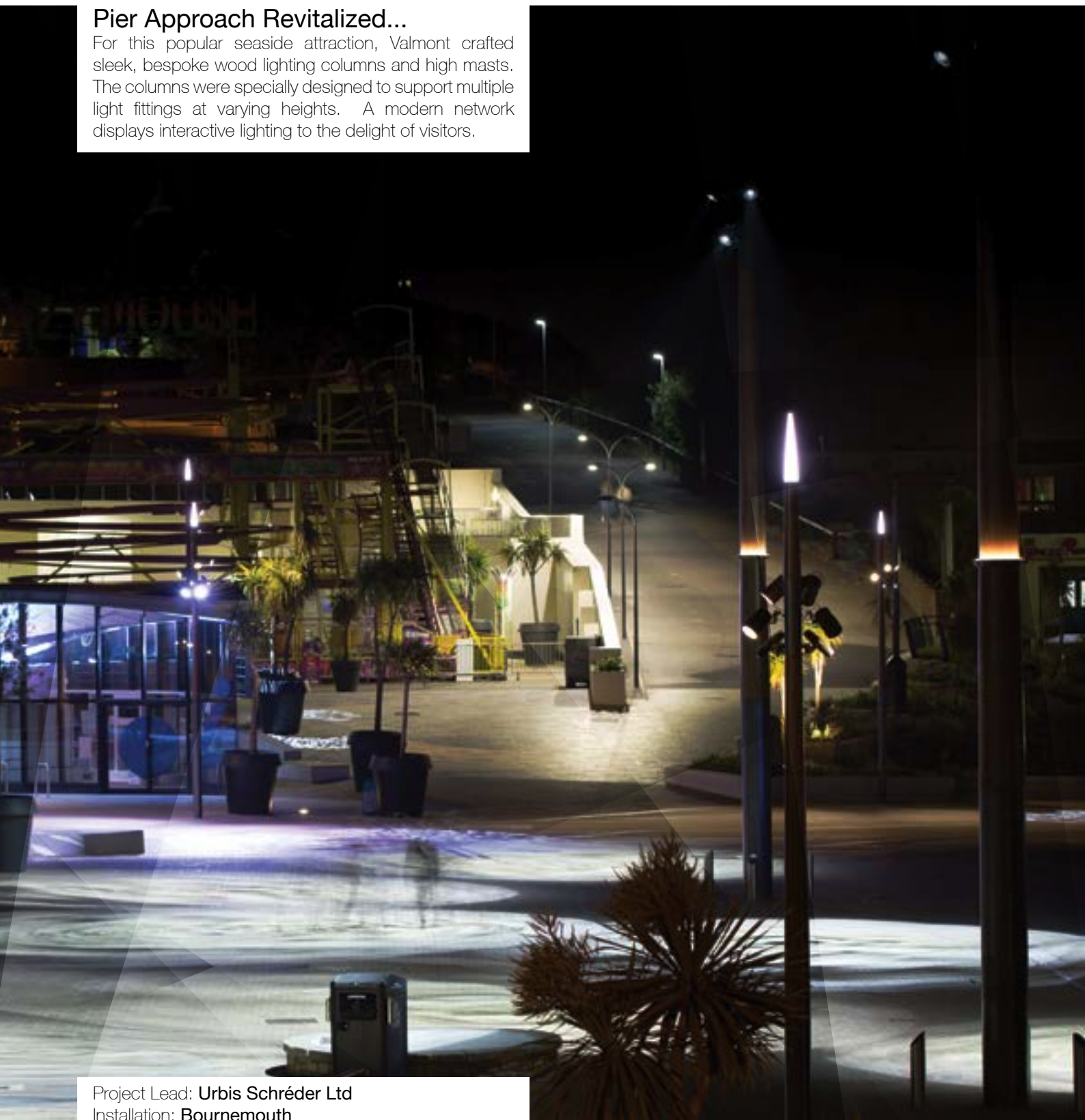

Project Lead: **Urbis Schröder Ltd**
Installation: **Bournemouth**
Product: **Bespoke wooden columns**



Description:

8m galvanized stepped tubular lighting columns.

Columns are fitted with post top mounted LED's.



Spend To Save...

For this project, functionality, economy & quality were at the forefront of this design brief from Stockton on Tees Borough Council. A enduring modern tubular design complementing the LED lantern's sleek aesthetic.



Project Lead: **Stockton on Tees BC**
Installation: **Norton**
Product: **Galvanised stepped tubular columns**

Durham Gates United Kingdom



Description:

8m Courbe and Sigma ldyline columns,
5m parallel stainless steel columns,
5m & 6m galvanised steel powder coated columns.

Columns are fitted with a mixture of post top lanterns,
stub arm mounted lanterns and illuminated finials.



Mixity Realised ...

The regeneration of Durham Gates utilizes a tasteful mix of stainless steel, galvanised steel and a varying array of Idyline aluminium columns. This combination gives the installation a unique identity and showcases the boulevard by highlighting the "D" and "G" forms.



Project Lead: **Thorn Lighting (ZG-UK)**,
 Installation: **Durham Gates**
 Product: **Idyline, parallel stainless steel and parallel powder coated columns**

Hamad International Airport Doha, Qatar



Description:

28m Bespoke, raise and lower high mast structures.
Steel Core with decorative cladding.

Columns are fitted with a decorative cladding featuring arabesque calligraphy.

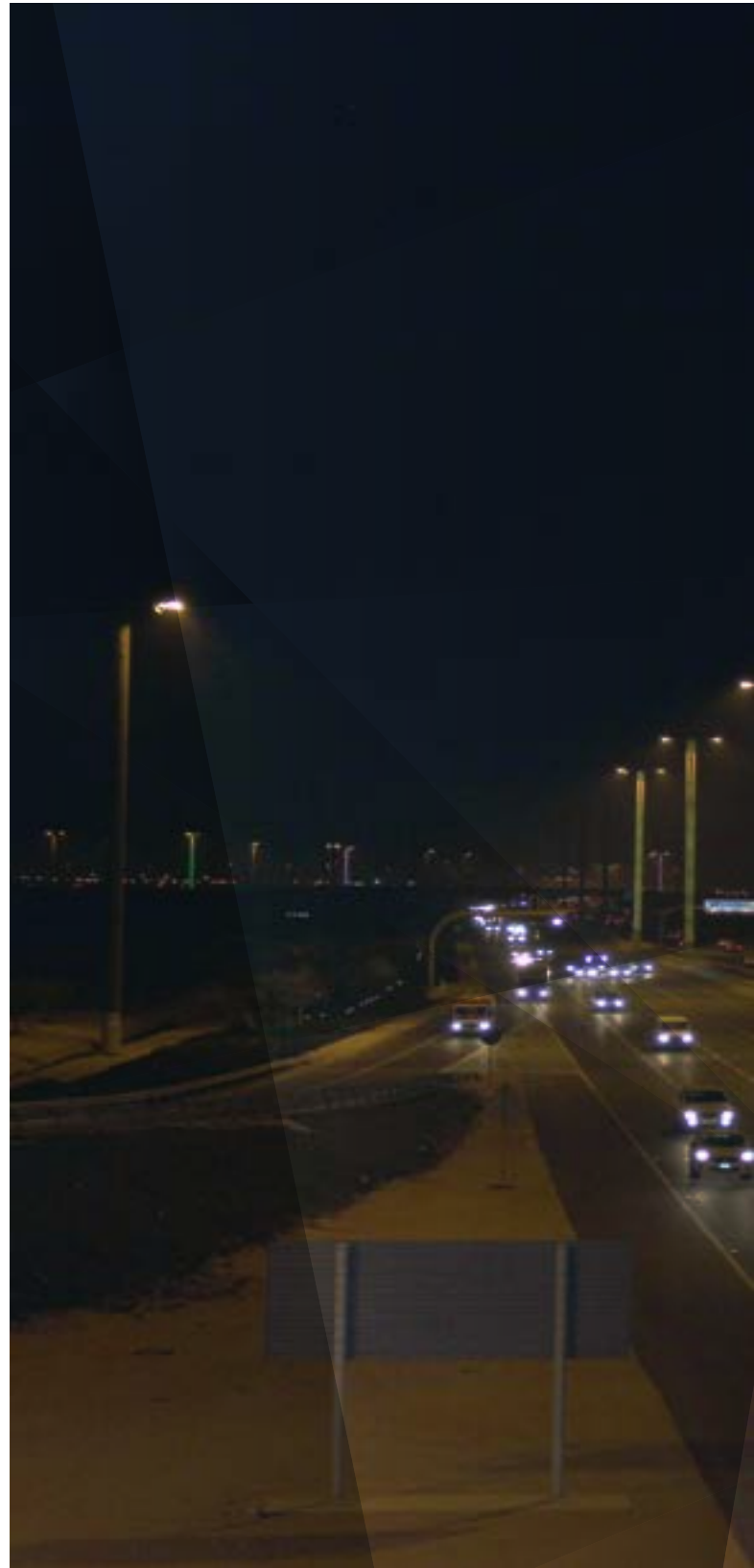

Illumination Innovation...

These 28m bespoke high-masts at Hamad International Airport in Doha, Qatar, provide a visual oasis. The Valmont-crafted masts are internally illuminated and feature an intricate laser-profiled exterior cladding. The light fixtures can be raised and lowered via electronic control for maintenance.

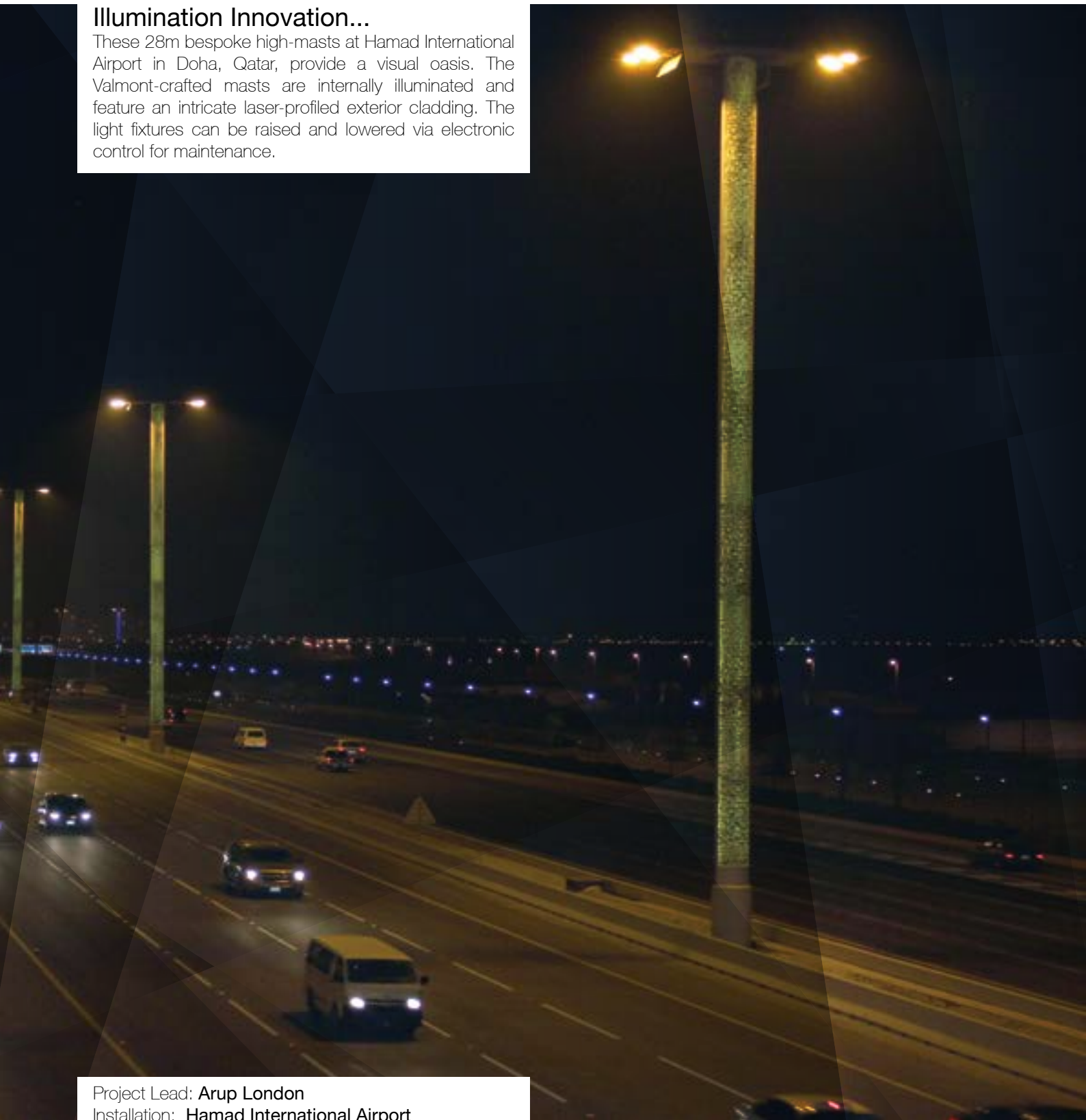

Project Lead: **Arup London**
Installation: **Hamad International Airport**
Product: **Bespoke Highmast**



Description:

10m Galvanised octagonal lighting columns

Columns are fitted with 2m rise radiused single and double arm brackets



Covering All Angles...

In this case Valmont had to consider an exposed elevated environment, in conjunction with a traditional aesthetic that blends seamlessly with the existing street lighting infrastructure. An enduring design that performs exceptionally in aggressive conditions.



Project Lead: **Stockton on Tees BC**
 Installation: **Ingleby Barwick**
 Product: **Galvanised octagonal columns CTEA80 & MD/C1502**



Description:

4m Conical wooden lighting columns.
GL28h glued-laminated timber, PEFC certified.

Illuminated steel bollards.





Timeless Integration...

St Mary's School Ascot is a leading Roman Catholic boarding school for girls. Set across a large 55 acre site, in the heart of Berkshire. The simple, conical wooden lighting columns are paired with illuminated bollards to create a lighting package that seamlessly blends into its environment.

Project Lead: **Urbis Schréder Ltd**
 Installation: **St. Mary's School Ascot**
 Product: **Conical wooden columns, Illuminated bollards.**

Hull Public Realm United Kingdom



Description:

Seamless conical columns at varying heights.

Bespoke modular bracketry designed to facilitate ultra flexible event lighting.



City of Culture...

Large scale seamless conical columns and custom modular cuboid brackets incorporating state of the art lighting products and controls to create a landmark installation. The Arup driven design focusses on the flexibility of the solution to support exacting artist lead lighting requirement for the building facade, while maintaining appropriate area lighting for the public square. The resulting solution delivered a sleek and slender form that supports, yet doesn't compete with, the urban context of the 2017 UK City of Culture.



Project Lead: **Arup**
Client: **Hull City Council**
Installation: **Hull Public Realm**
Product: **Bespoke large scale conical columns**



Description:

6m Custom Stepped tubular columns suited to CCTV and WiFi use.

Galvanised with powder coated decorative finish.



Performance Meets Tradition...

Security and performance were the main drivers for this custom installation. The combination of traditional stepped tubular columns, multi-function capability, and a high-end coating blend seamlessly with the premium feeling conveyed by this installation site



Project Lead: **Sitico - Osram**
Installation: **Stockton, Porsche**
Product: **Bespoke stepped tubular columns**

E6 Highway

Strandlykkja, Norway



Description:

12m bespoke tilted, wooden columns.
GL28h glued-laminated timber, PEFC certified.

5m stainless steel columns, grade 304L.
Wooden columns are fitted with integral LED panels.

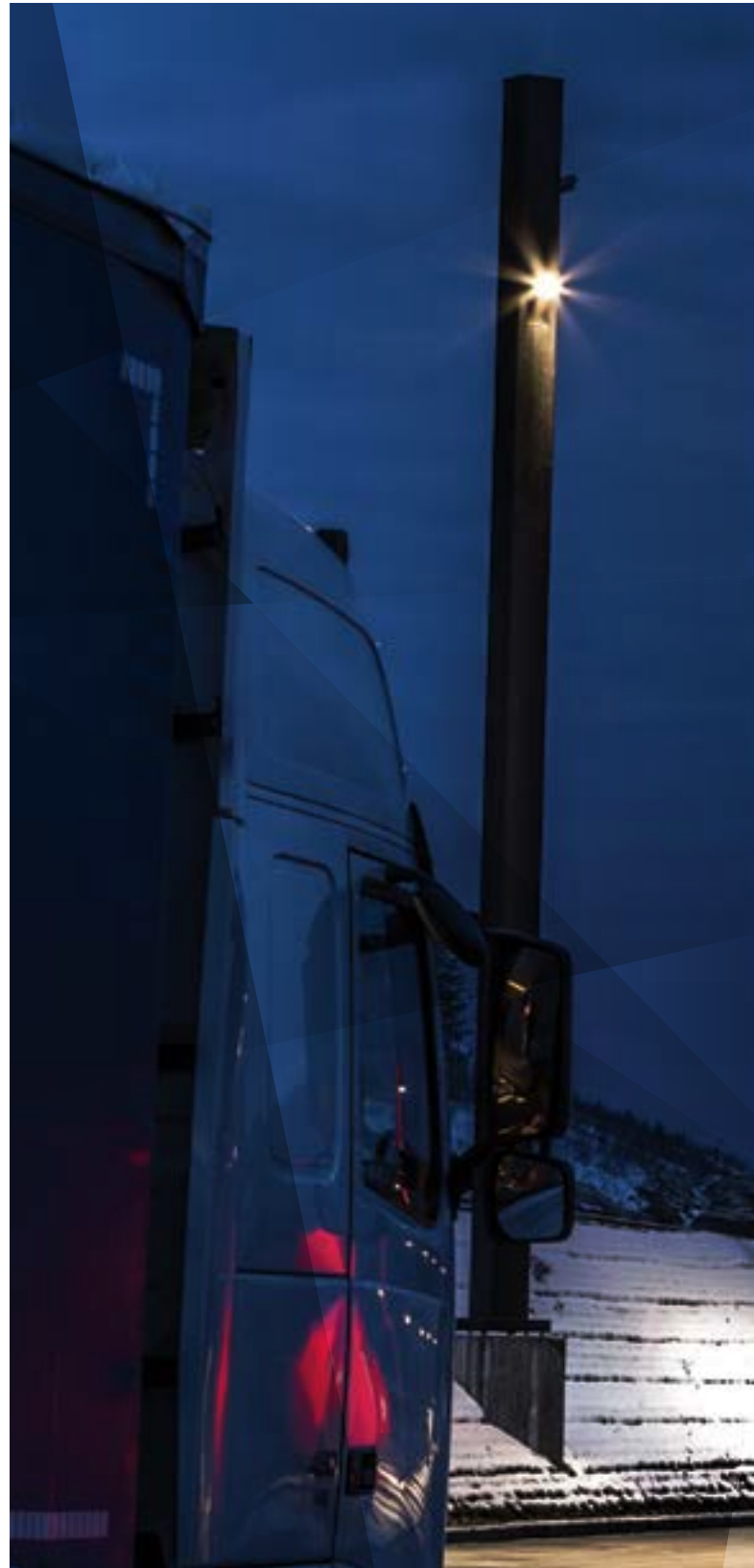

A Beacon in a Rugged Landscape...

Installed at key rest areas along the scenic E6 highway north of Oslo are lighting columns with integral LED panels. The columns are installed at varying angles to complement the unique geography at each site. The innovative illumination helps rejuvenate drivers to maintain alertness through long winter-night drives.



Project Lead: **Tehomet**
Installation: **E6 Norway**
Product: **Bespoke wooden columns and cylindrical stainless steel columns.**

Granary Square United Kingdom



Description:

13m Bespoke ladder bar structure
Steel

Columns are fitted with an indirect lighting system.

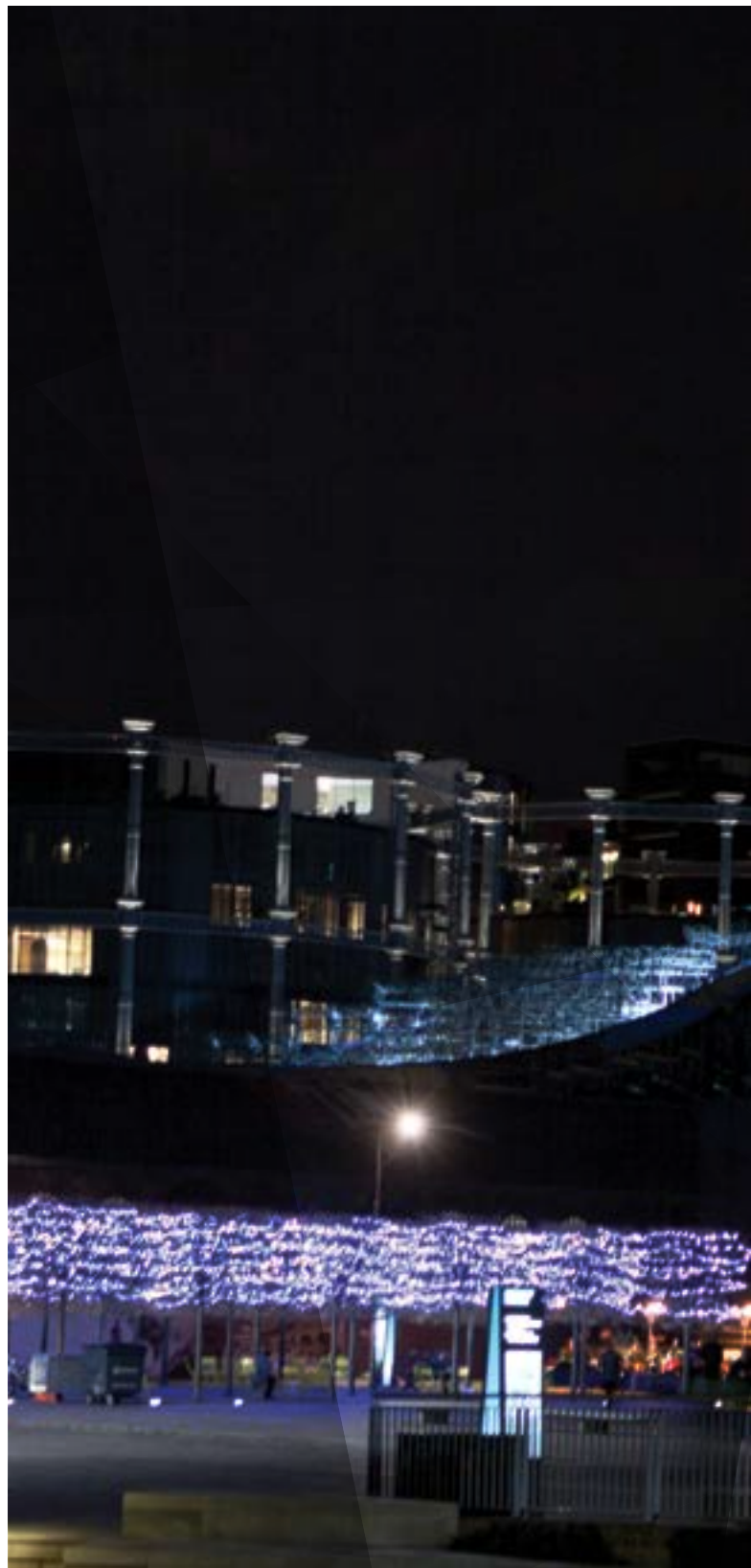

Inspired Design...

Overlooking Regent's Canal, this public square plays host to festivals and concerts. Attractive area lighting columns feature a galvanised-steel, ladder-bar structure, paying homage to the nearby railway tracks. The rail-tie design is a functional and aesthetic innovation, enhancing loading capabilities.



Project Lead: **Siteco Osram**
 Installation: **London Kings Cross Granary Square**
 Product: **Bespoke Ladder-bar Structure**



Description:

8m Idyline S5-02 columns.
9m Sillem K columns.

Columns are fitted with illuminated finials.



Lines Inspired by Nature...

The curved beauty of Idyline Signature columns grace the driveway and new sports complex at University of Derby. Also, the organic lines of Sillem Signature columns complement the scenic memorial pond. A distinctive capstone to these lighting columns is an illuminated finial.



Project Lead: **Thorn Lighting**
 Installation: **University of Derby**
 Product: **Idyline & Sillem aluminium columns**



Description:
55m Galvanised steel polygonal sports lighting columns.

Columns are fitted with tilted headframe assemblies supporting up to 88 floodlights.



Howsat!

A Critical lighting performance driven project, utilising the largest lighting structures in the UK! These massive structures carry up to 88No. floodlights per column, ensuring both illumination and uniformity levels required for the fast paced sport.



Project Lead: Musco Lighting
Installation: Durham CCC
Product: 55m Sports floodlighting mast

Middlesbrough Sports Village United Kingdom



Description:

Galvanised Derwent octagonal mid-hinged floodlighting columns.

Columns are fitted with post top cross arm arrangement.
Note: Design also caters for a track side integrated loudspeaker system.

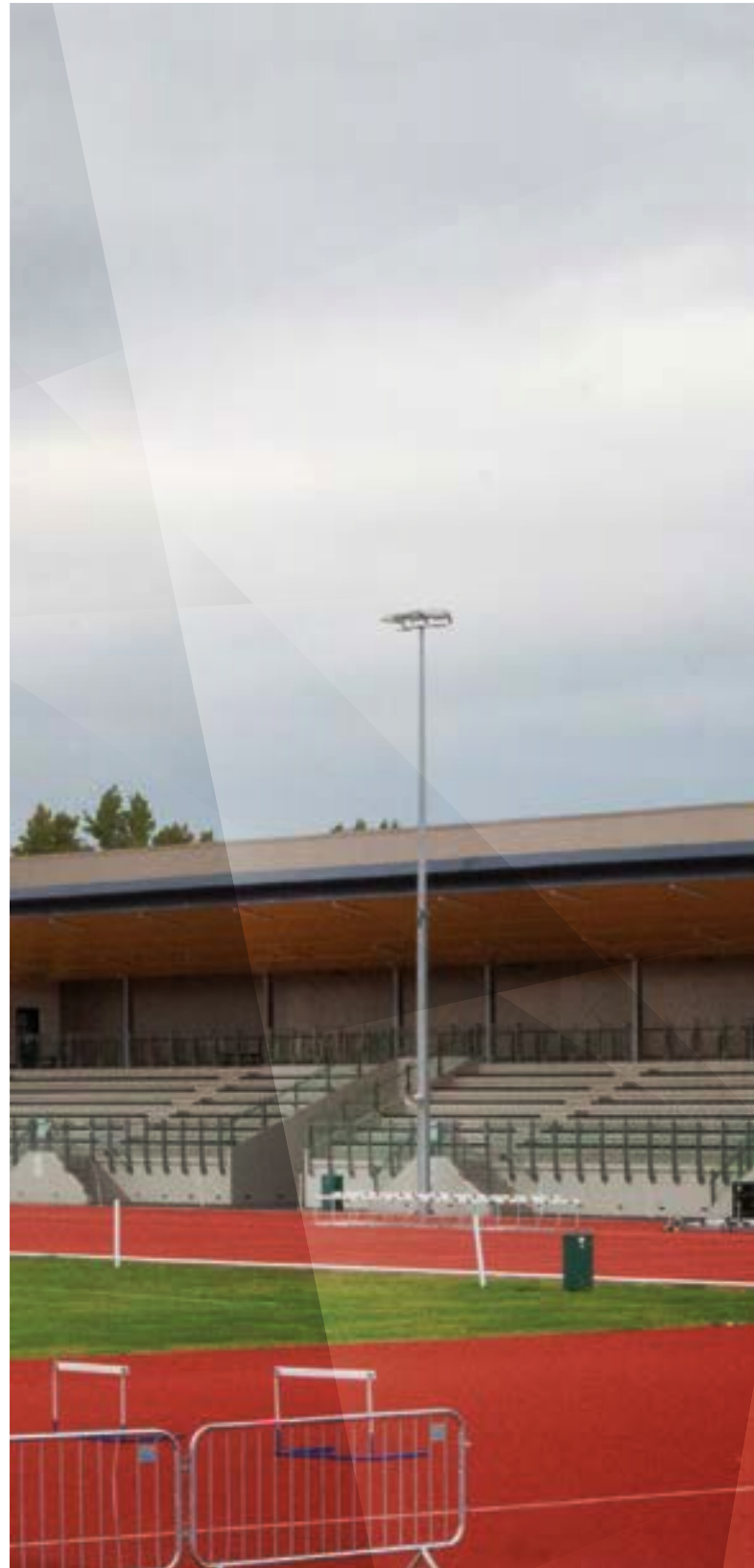

Maintenance Made Easy...

A complex mix of sports lighting requirements ranging from eight lane 400m track, ten lane 100m track, four long jump pits, high jump, hammer throwing, javelin, as well as 5 No. outdoor 3G football pitches, all catered for from this flexible use range of products that include the ease of lantern maintenance from ground level.



Project Lead: **Philips Lighting**
Installation: **Middlesbrough Sports Village**
Product: **10m, 12m & 15m Derwent galvanised octagonal mid-hinged sports floodlighting columns.**



Description:

15m Altor decorative conical columns.
6m Conical Steel and stainless steel columns.

Columns are fitted with multiple lanterns and projectors.



Feel Good Space...

Combination of 6m and 15m tapering structures with architectural finishing are a perfect addition to a newly landscaped area. This installation encompasses an array of lighting applications ranging from traditional street lighting to specialist ground, and vibrant wall projections. The result is a fun, energetic and inviting space for campus visitors.



Project Lead: **WE-EF UK**
Installation: **Teesside University**
Product: **Altor conical steel columns**



EC Certificate of Conformity Certificate No. 0086-CPD-582446

In compliance with Council Directive 89/105/EEC of 21 December 1988 on the approximation of laws, regulations and administrative provisions of the Member States relating to construction products (the Construction Products Directive or CPD), as later amended, it has been stated that the construction product

Steel Lighting Columns

Valmont Stainton steel lighting column size limitations 0m to ≤ 20 m

placed on the market by

Valmont Stainton Ltd

Dukesway, Teesside Industrial Estate, Stockton-on-Tees, TS17 9LT, United Kingdom

and manufactured at the following location

Valmont Stainton Ltd

Dukesway, Teesside Industrial Estate, Stockton-on-Tees, TS17 9LT, United Kingdom

is submitted by the manufacturer to a factory production control and that the notified body BSI has performed the initial type-testing for the relevant characteristics of the product, the initial inspection of the factory and of factory production control and performs the continuous surveillance, assessment and approval of factory production control.

This certificate attests that all provisions concerning the attestation of conformity and the performances described in Annex ZA of the Standard(s)

EN 40-5:2002

were applied and that the product fulfils the prescribed requirements.

This certificate remains valid as long as the conditions laid down in the harmonised standard in reference or the manufacturing conditions in the factory or the FPC itself are not modified significantly.

For and on behalf of BSI, a Notified Body for the above Directive (Notified Body Number 0086).

Gary Fenton, Global Assurance Director

First Issued: 12 March 2013

Page 1 of 1

Latest Issue: 12 March 2013

...making excellence a habit™

Information and Contact: BSI, Kitemark Court, Davy Avenue, Knowlhill, Milton Keynes MK5 8PP. Tel: +44 (0)845 080 9000



CTICM
Espace Technologique – L'orme des Merisiers
Immeuble Apollo – 91193 SAINT-AUBIN

Certificate of constancy of performance For a range of metallic lighting columns according to EN 40-5: 2002 and EN 40-6: 2002

Delivered in compliance with Regulation 305/2011/EU of the European Parliament and of the Council of 9 March 2011. This certificate applies to the construction product:

Metallic lighting column: Steel and aluminium straight columns and columns with brackets

Placed on the market by: VALMONT France SAS
Les Marmoulets
93110 CHARMEL

And produced in the factory: CHARMEL (03) and RIVE DE GIER (42)

The product is submitted by the manufacturer to a factory production control. The initial type-testing for the relevant characteristics of the product, the initial inspection of the factory and of the factory production control have been performed under the responsibility of the notified body CTICM. CTICM also performs the continuous surveillance, assessment and approval of the factory production control.

This certificate attests that all provisions concerning the assessment and verification of constancy of performance of the Steel and aluminium straight columns and columns with brackets, described in Annex ZA of the standard EN 40-5 : 2002 and EN 40-6 : 2002, were applied and that product fulfils all the prescribed requirements.

This certificate was first issued on the 10th March 2005 and remains valid as long as the conditions laid down in the harmonised technical specification in reference or the manufacturing conditions or the FPC itself are not modified.

Reference of the range: the list of product references for the range is a document referenced n° GA/000/183 and P09/A02/173, kept up to date by the producer.

This certificate allows the manufacturer, its mandatories or its distributors, stated in the European Economic Area, to affix the CE marking.

Certificate number
1166 – CPR – 0003

Date of the present certificate, Saint-Aubin, October 9th 2015

CE
1166

Patrick Le Chafforet
Certification Director

The present authorized document referenced **RC02-0003-010** is a translation of the original document. Only the French version is official. The original version includes 2 pages including one annex. Only its integral reproduction is permitted.



Page 1/2



Notified body No. 0809
VTT EXPERT SERVICES LTD
Certification and Product Approval
P.O. Box 1001, FI-02044 VTT, Finland

CERTIFICATE OF CONSTANCY OF PERFORMANCE

0809 - CPR - 1005

In compliance with Regulation 305/2011/EU of the European Parliament and of the Council of 9 March 2011 (the Construction Products Regulation or CPR), this certificate applies to the construction product

GLUED LAMINATED TIMBER

the strength class of which is GL32, GL28 or GL24,
the species used are spruce (*Picea abies*) or pine (*Pinus sylvestris*)
and the adhesive used is of type I;

produced by

Metsäliitto Cooperative
Metsä Wood, Kuningaspalkki
Kurpanpellontie
FI-19600 Hartola, Finland

and produced in the manufacturing plant

Hartola mill
Kurpanpellontie
FI-19600 Hartola.

This certificate attests that all provisions concerning the assessment and verification of constancy of performance and the performances described in Annex ZA of the standard

EN 14080:2005

under system 1 are applied and that

the product fulfils all the prescribed requirements set out above.

This certificate was first issued on July 15, 2013 and will remain valid as long as the test methods and/or factory production control requirements included in the harmonised standard, used to assess the performance of the declared characteristics, do not change, and the product, and the manufacturing conditions in the plant are not modified significantly.

Espoo July 15, 2013

Liisa Rautainen
Assessment Manager

Mikael Fonselius
Lead Assessor



Certificate of Registration

QUALITY MANAGEMENT SYSTEM - ISO 9001:2008

This is to certify that: **Valmont Stainton Limited**
 Dukesway
 Teesside Industrial Estate
 Stockton-on-Tees
 TS17 9LT
 United Kingdom

Holds Certificate Number: **FM 566156**

and operates a Quality Management System which complies with the requirements of ISO 9001:2008 for the following scope:

The manufacture of galvanised and stainless steel lighting columns, high masts and cable support columns in cylindrical or folded section, in accordance with National Highway Sector Scheme 6 - manufacture, supply and verification of lighting columns and bracket arms. The procurement, storage, and supply of aluminium columns.

For and on behalf of BSI:

 Frank Lee, EMEA Compliance & Risk Director

Original Registration Date: 16/08/2010
 Latest Revision Date: 24/12/2015

Effective Date: 02/01/2016
 Expiry Date: 14/09/2018

Page: 1 of 1



...making excellence a habit.™

This certificate was issued electronically and remains the property of BSI and is bound by the conditions of contract.
 An electronic certificate can be authenticated [online](#).
 Printed copies can be validated at www.bsigroup.com/ClientDirectory

Information and Contact: BSI, Kitemark Court, Davy Avenue, Knowlhill, Milton Keynes MK5 8PP. Tel: + 44 845 080 9000
 BSI Assurance UK Limited, registered in England under number 7905321 at 389 Chiswick High Road, London W4 4AL, UK.
 A Member of the BSI Group of Companies.

 **Certificate**
No. 5674-03

Inspecta

Inspecta Sertifointi Oy has granted this certificate to

Tehomet Oy
Parikkala

The certificate verifies that the chain of custody of wood based raw material
complies with standards

PEFC ST 2002:2013, PEFC ST 2001:2008 v2

Certification covers

Manufacturing of decorative wooden lighting columns.

The certificate is issued on 2014-01-14
(first issue 2009-08-14).
The certificate is valid until 2017-12-28.

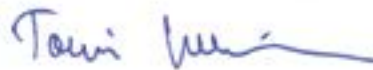

Tomi Kasurinen, Managing Director

The certificate is valid on condition that the chain of custody
remains in compliance with the aforementioned standard and the General Regulations ABC 750.
The validity of the certificate can be checked on the Internet at www.inspecta.fi



Inspecta Sertifointi Oy
P.O. Box 1000, Sömästenkatu 2
FI-00581 Helsinki, Finland
Tel. +358 10 521 600

Group headquarters: Inspecta Group Oy, Helsinki, Finland

TRUST & QUALITY www.inspecta.com



trees for all
Certificaat

Ondergetekende verklaart dat Trees for All de uitstoot van broeikasgassen compenseert voor de bedrijfsvoering van:

Valmont

In de periode 2014

Hiertoe wordt de uitstoot van

408,9 ton CO₂

duurzaam vastgelegd in de vorm van Jatropha struiken in Mali, waardoor de uitgestoten broeikasgassen geen bijdrage meer leveren aan de versterking van het broeikaseffect

Arnhem, 01 juni 2014
Dhr. ir. J. Bos, Voorzitter

Certificaatnummer 0oZZ002-Z-120515-20



www.treesforall.nl



By Royal Charter

Certificate of Conformity of the Factory Production Control

This is to certify that:

Valmont Stainton Ltd.
Dukesway
Teesside Industrial Estate
Stockton-on-Tees
TS17 9LT
United Kingdom

Holds Certificate Number:

0086-CPR-617380

In respect of:

EN 1090-1:2009+A1:2011 - Execution of steel structures and aluminium structures.

The design and manufacture (including welding) of structural work in steel up to and including Execution Class 3 (EXC 3) as defined in EN 1090-2.

In compliance with Regulation 305/2011/EU of the European Parliament and of the Council of 9 March 2011 (the Construction Products Regulation or CPR), this certificate applies to the above construction product. This certificate attests that all the provisions concerning the assessment and verification of constancy of performance described in Annex ZA of the above standard(s) under system 2+ are applied and that the product fulfils (products fulfil) all the prescribed requirements set out above. This certificate remains valid as long as the test methods and/or factory production control requirements included in the harmonised standard(s), used to assess the performance of the declared essential characteristics, do not change and the products(s), and the manufacturing conditions in the plants(s) are not modified significantly.

For and on behalf of BSI, a Notified Body for the above Regulation (Notified Body Number 0086):

Chris Lewis - Certification Director, Product Certification

First Issued: 2014-11-14

Latest Issue: 2017-11-30

Page: 1 of 2

...making excellence a habit.™

This certificate has been issued by and remains the property of BSI Assurance UK Ltd, 389 Chiswick Court, Devy Avenue, Knowlton, Milton Keynes MK5 8PP, United Kingdom and should be returned immediately upon request. To check its validity telephone +44 (0) 345 080 9000. An electronic certificate can be authenticated [online](#).

BSI Assurance UK Limited, registered in England under number 7905321 at 389 Chiswick High Road, London W4 4AL, UK. A member of BSI Group of Companies.

Certificate of Conformity of the Factory Production Control

No. 0086-CPR-617380

Manufacturing Plant

Valmont Stainton Ltd.
Dukesway
Teesside Industrial Estate
Stockton-on-Tees
TS17 9LT
United Kingdom

Certified Activities

EN 1090-1:2009+A1:2011 - Execution of steel structures and aluminium structures.

The design and manufacture (including welding) of structural work in steel up to and including Execution Class 3 (EXC 3) as defined in EN 1090-2.



First Issued: 2014-11-14

Latest Issue: 2017-11-30

Page: 2 of 2

This certificate has been issued by and remains the property of BSI Assurance UK Ltd, Kitemark Court, Davy Avenue, Knowlton, Milton Keynes MK5 8PR, United Kingdom and should be returned immediately upon request.
To check its validity telephone +44 (0) 345 080 9000. An electronic certificate can be authenticated [online](#).

BSI Assurance UK Limited, registered in England under number 7905321 at 389 Chiswick High Road, London W4 4AL, UK.
A member of BSI Group of Companies.



Certificate of Constancy of Performance

This is to certify that:

Valmont Stainton Limited
 Dukesway
 Teesside Industrial Estate
 Stockton-on-Tees
 TS17 9LT
 United Kingdom

Holds Certificate Number: 0086-CPR-622474

In respect of:
EN 12899-1 Fixed vertical road traffic signs

In compliance with Regulation 305/2011/EU of the European Parliament and of the Council of 9 March 2011 (the Construction Products Regulation or CPR), this certificate applies to the above construction product. This certificate attests that all the provisions concerning the assessment and verification of constancy of performance described in Annex ZA of the above standard(s) under system 1 are applied and that the product fulfils (products fulfil) all the prescribed requirements set out above. This certificate remains valid as long as the test methods and/or factory production control requirements included in the harmonised standard(s), used to assess the performance of the declared essential characteristics, do not change and the products(s), and the manufacturing conditions in the plants(s) are not modified significantly.

For and on behalf of BSI, a Notified Body for the above Regulation (Notified Body Number 0086):

 Gary Fenton, Global Product Certification Director

First Issued: 29/03/2016

Latest Issue: 29/03/2016

Page: 1 of 2

...making excellence a habit™

This certificate has been issued by and remains the property of BSI Assurance UK Ltd, 389 Chiswick High Road, Uxbridge, Middlesex, UK. It should be returned immediately upon request. To check its validity telephone +44 (0) 845 080 9000. An electronic certificate can be authenticated [online](#).

BSI Assurance UK Limited, registered in England under number 7805321 at 389 Chiswick High Road, London W4 4AL, UK. A member of BSI Group of Companies.

Certificate of Constancy of Performance

No. 0086-CPR-622474

EN 12899-1:2007 - Fixed vertical road traffic signs.

Place of manufacture: Valmont Stainton Limited
Dukesway
Teesside Industrial Estate
Stockton-on-Tees
TS17 9LT
United Kingdom



First Issued: 29/03/2016

Latest Issue: 29/03/2016

Page: 2 of 2

This certificate has been issued by and remains the property of BSI Assurance UK Ltd, Kitemark Court, Davy Avenue, Knowlhill, Milton Keynes MK5 8PP, United Kingdom and should be returned immediately upon request.
To check its validity telephone +44 (0) 845 080 9000. An electronic certificate can be authenticated [online](#).

BSI Assurance UK Limited, registered in England under number 7905321 at 389 Chiswick High Road, London W4 4AL, UK.
A member of BSI Group of Companies.

Installation Foundations

Installation of Planted Root Lighting Columns.

Installation Preparation.

Before commencement of installation examine the items and ensure that there are no missing or damaged parts.

The following items of equipment will be required to install the column(not supplied by Valmont Stainton).

1. Timber supports and packers
2. A mobile crane for erection, typically 1.0 tonne
3. A lump hammer etc for adjustment.

The relevant technical literature or column/bracket Appendix 13/2 data sheet should be consulted for each column to ascertain the correct concrete diameter(if any) required. Typical example of a Foundation Spreadsheet for planted root columns can be obtained to accompany this document if required.

Dependent upon the ground conditions, it may be prudent to place a concrete paving slab or similar anti-sink feature at the base of the foundation hole.

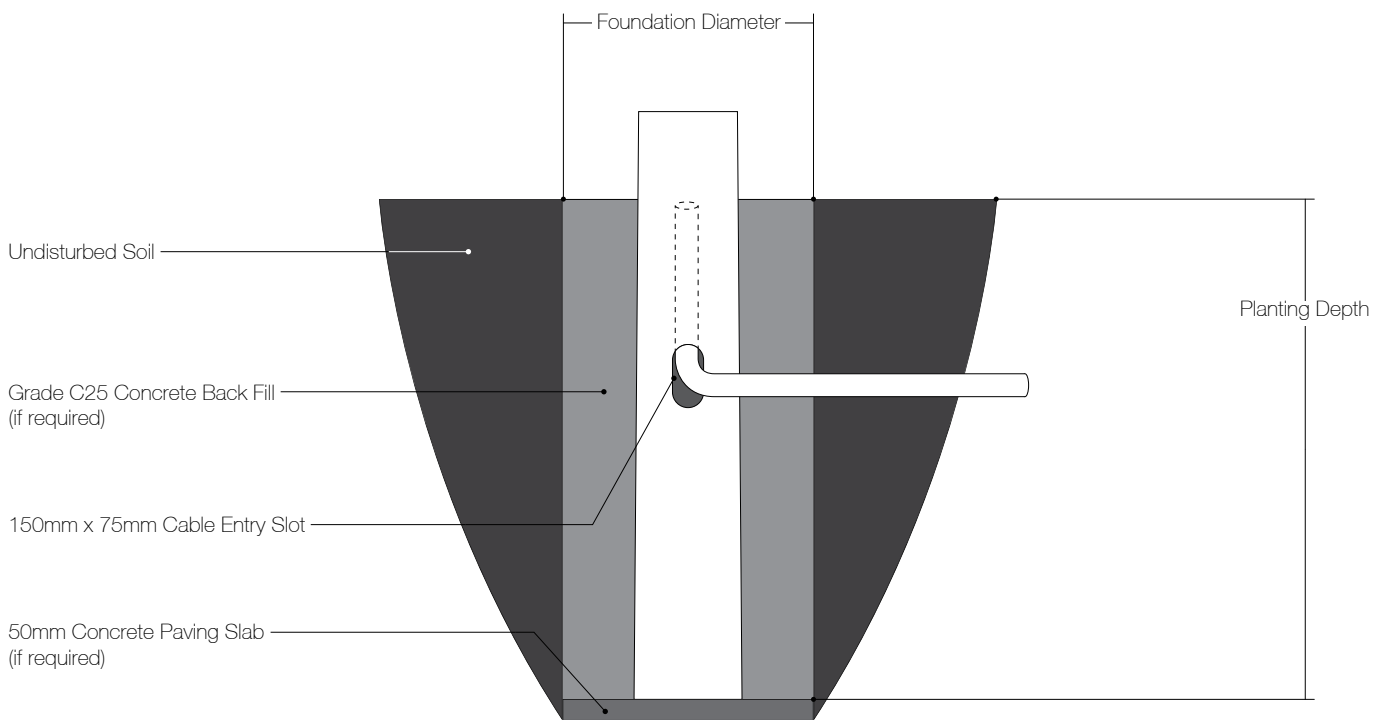

Column Installation.

Use a crane to lift the column and place the root section into the previously prepared foundation hole. Ensure that the orientation of the door opening is as required and cable protection sleeve(duct) is fed through the column cable entry slot, to allow for installation of electric cabling.

Plumb up the base section of the column and use timber packing to hold the column in position. Back fill the hole with either concrete or the excavated material(or better quality), upto ground level. All back filling using excavated material should be placed in 150mm thick layers and must be well compacted.

If concrete surround is used, ensure the correct curing time is allowed before further commissioning of the column installation.

Installation of Flange Plated Lighting Columns.

Installation of Anchor Bolts & Column Levelling.

To ensure that the Anchor Bolts are cast in their correct position they should be held in place using an accurately manufactured Foundation Template (drawing/sketch on request). It is recommended that the full threaded length of the anchor bolt be left protruding above the upper surface of the concrete foundation. Prior to casting of the concrete a Cable Duct should be positioned to enable cables to exit the concrete block centrally under the column flange plate. After the concrete has cured the foundation template may be discarded or re-used, i.e. dependent upon number of templates used.

Each anchor bolt is supplied with 3 nuts and 2 washers, we recommend that one nut and washer [on each bolt] be assembled on the underside of the Lighting Column Flange and are used as a means of levelling/plumbing the Lighting Column. Once the column is positioned and plumbed as required one nut and remaining washer can be tightened to firmly hold the Lighting Column in place. The final nut is then used as a lock nut.

It is recommended that the gap between the underside of the column flange and the concrete foundation block be filled with Shrink Proof Grouting Mortar of the same grade as the main concrete mass. A small gap must be left in the grouting mortar to enable moisture and condensation to escape from the inside of the column base compartment.

After installation the exposed threaded section of the anchor bolts should be protected against corrosion using wax coated tape ["Denso" tape], or by using grease caps or zinc rich paint.

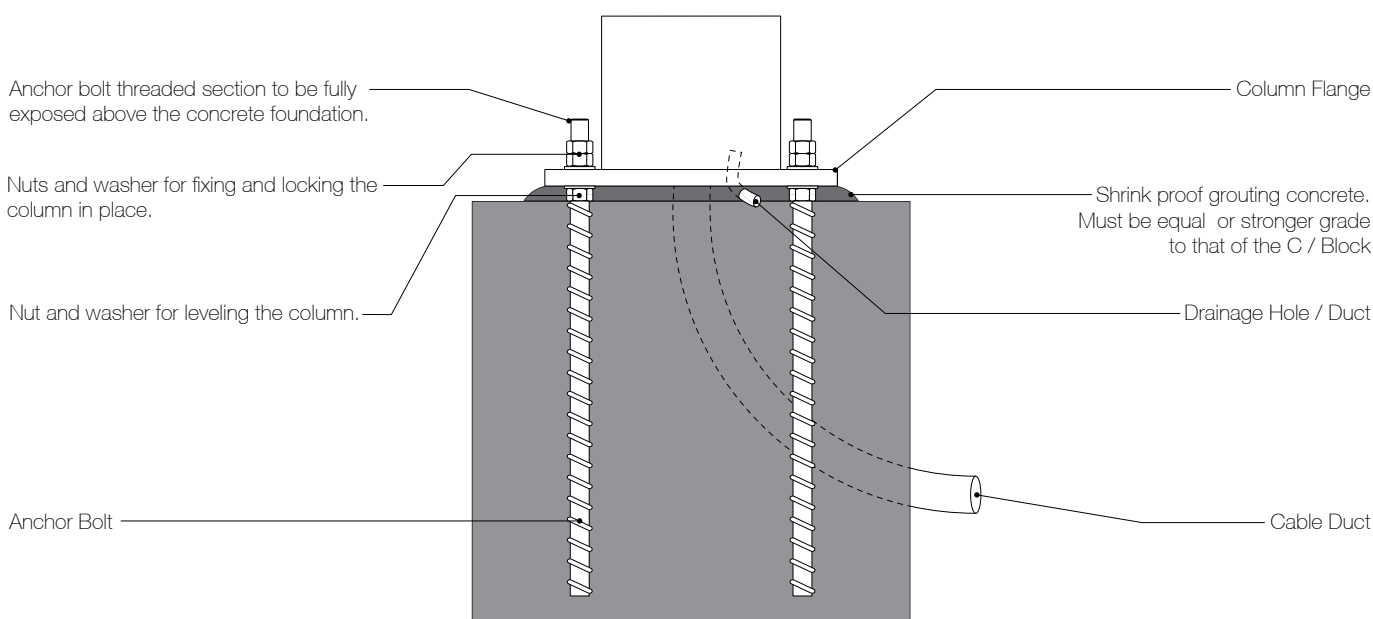

Torque Settings.

For non preloaded bolts the requirement is to bring the assembly to at least a snug tight condition. The definition below for snug tight is taken from BS EN 1090-2 – Execution of Steel Structures.

Each bolt assembly shall be brought at least to a snug-tight condition, with special care being given to avoid over-tightening especially short bolts and M12. The tightening process shall be carried out from bolt to bolt of the group, starting from the most rigid part of the connection and moving progressively towards the least rigid part. To achieve a uniform snug-tight condition, more than one cycle of tightening may be necessary.

NOTE 1 The most rigid part of a cover plate connection of an I section is commonly in the middle of the connection bolt group. The most rigid parts of end plate connections of I sections are usually beside the flanges.

NOTE 2 The term “snug-tight” can generally be taken as that achievable by the effort of one man using a normal sized spanner without an extension arm, and can be set as the point at which a percussion wrench starts hammering.

Terms and Conditions

1.1 In these Conditions, "Buyer" means the person whose order for the Goods is accepted by the Seller; "Seller" means Valmont/Stainton Limited; "Goods" means the goods which the Seller is to supply in accordance with these Conditions; "Conditions" means these terms and conditions and (unless the context otherwise requires) includes any special terms and conditions agreed in writing between the Buyer and Seller; "Contract" means the contract for the purchase and sale of the Goods.

2.1 The Seller shall sell and the Buyer shall buy the Goods in accordance with any written order of the Buyer which is accepted by the Seller. All Contracts are made expressly subject to these Conditions, which Conditions can only be varied in writing by an authorised representative of the Seller. These Conditions shall have precedence over any standard terms and conditions which the Buyer may seek to impose.

3.1 No order submitted by the Buyer shall be deemed to be accepted by the Seller unless and until confirmed in writing by the Seller's authorised representative.

3.2 Once the Buyer's order has been accepted by the Seller, no cancellation by the Buyer shall be effective to terminate the Contract.

3.3 The Seller reserves the right at all times and without liability to the Buyer to vary the specifications and descriptions appearing in the Seller's printed matter. Weights, dimensions and other technical data given are approximate only.

4.1 Any price quotations are valid only for a period of 30 (thirty) days from the date they were made.

4.2 Unless otherwise agreed in writing between the Seller and the Buyer, all prices are given by the Seller on an ex-works basis.

4.3 The price to be paid by the Buyer for Goods shall be the Seller's current price at the date of despatch, which price may have been varied to reflect any increase in the cost to the Seller since the date of the Buyer's order, caused, without limitation, by increases in the cost of materials and labour.

4.4 The price is exclusive of any applicable value added tax, which the Buyer shall be additionally liable to pay to the Seller.

5.1 Unless otherwise agreed in writing between the Seller and the Buyer, the Seller shall be entitled to invoice the Buyer for the price of the Goods on or at any time after delivery of the Goods, unless the Goods are to be collected by the Buyer or the Buyer wrongfully fails to take delivery of the Goods, in which event the Seller shall be entitled to invoice the Buyer at any time after the Seller has notified the Buyer that the Goods are ready for collection or the Seller has tendered delivery of the Goods.

5.2 The Buyer shall pay the price of the Goods without any deduction or set-off within 30 days of the date of the Seller's invoice. Time of payment is of the essence.

5.3 The Seller's right to receive payment in full on the due date shall not be affected by any question of erection or assembly of the Goods, nor by any damage to or loss of the Goods in transit, nor by any assertion of alleged defect.

5.4 If the Buyer fails to make payment on the due date then, without prejudice to any other right or remedy available to the Seller, the Seller shall be entitled to:

5.4.1 cancel the Contract or suspend any further deliveries to the Buyer;

5.4.2 charge the Buyer interest upon the amount unpaid at a rate of five per cent per annum above Barclays Bank plc base rate from time to time until payment in full is made; and

5.4.3 require pre-payment of or such other security as may be required for the payment of the price of any further delivery.

5.5 The Buyer's failure to adhere strictly to payment or part payment on the due date shall automatically render any agreed credit terms null and void in respect of the unpaid balance of the value and the whole unpaid balance shall immediately fall due.

6.1 Delivery of the Goods shall be made by the Buyer collecting the Goods at the Seller's premises at any time after the Seller has notified the Buyer that the Goods are ready for collection or, if some other place for delivery is agreed by the Seller, by the Seller delivering the Goods to that place.

6.2 Where the price includes delivery charges, this shall be understood only to be to one address, in one or more consignments at the Seller's sole option, "Consignee" to off-load without delay.

6.3 Time of delivery of the Goods is not of the essence of the Contract and the Seller shall not be liable for any consequences of delay in delivery of the Goods, however caused. The Buyer shall not be entitled to cancel the Contract or to claim any damages arising out of late delivery.

6.4 If, when the Seller has notified the Buyer in writing, of the Seller's readiness to deliver the Goods, the Buyer requests the Seller to postpone delivery of the Goods, the Goods shall be placed in a storage area located at the Seller's option and held to the Buyer's order and at the Buyer's sole cost and risk pending physical delivery in accordance with the Contract. Payment for the Goods in these circumstances shall become due when the Seller notifies the Buyer of the Seller's readiness to deliver.

6.5 Where the Goods are to be delivered in instalments, each delivery shall constitute a separate Contract, and any default on the part of the Seller in respect of any part delivery shall not affect the due performance of the Contract as a whole, or entitle the Buyer to reject the remaining undelivered balance of the Goods, or to withhold payment therefore, or to any claim for compensation.

6.6 Transport, if included in the price, is arranged by the Seller through independent carriers or by the Seller's own transport at the Seller's sole option. In either case the said transport shall be entirely for the Buyer's own account and at his sole risk.

6.7 If the Goods are not received by the Buyer within 10 (ten) days of the date of the Seller's advice note, the Buyer shall give immediate notice thereof in writing.

7.1 Risk of damage to or loss of the Goods shall pass to the Buyer:

7.1.1 in the case of Goods to be delivered at the Seller's premises, at the time when the Seller notifies the Buyer that the Goods are available for collection; or

7.1.2 in the case of Goods to be delivered otherwise than at the Seller's premises, at the time of delivery or, if the Buyer wrongfully fails to take delivery of the Goods, the time when the Seller has tendered delivery of the Goods.

7.2 Notwithstanding delivery and the passing of risk in the Goods, or any other provision of these Conditions, the property in the Goods shall not pass to the Buyer until the Seller has received payment in full of the price of the Goods and all other goods agreed to be sold by the Seller to the Buyer for which payment is then due.

7.3 Until such time as the property in the Goods passes to the Buyer, the Buyer shall hold the Goods as the Seller's fiduciary agent and bailee, and shall keep the Goods separate from those of the Buyer and third parties and properly stored, protected and insured and identified as the Seller's property, but the Buyer shall be entitled to resell or use the Goods in the ordinary course of its business.

7.4 Until such time as the property in the Goods passes to the Buyer (and regardless of whether or not the Goods have been erected), the Seller shall be entitled at any time to require the Buyer to deliver up the Goods to the Seller and, if the Buyer fails to do so forthwith, to enter upon any premises of the Buyer or any third party where the Goods are located and repossess the Goods.

8.1 Save as provided in these Conditions, all conditions, warranties or other terms implied by statute, common law, custom of the trade or otherwise, are hereby excluded to the fullest extent permitted by law.

8.2 Subject to the provisions of this clause 8, the Seller warrants that on delivery of the Goods or on notification to the Buyer of the Seller's willingness to deliver the Goods pursuant to clause 6.4 and for a period of six (6) months from such date of delivery or notification the Goods will be free from defects in materials and workmanship.

8.3 The Seller will not be held liable for any breach of the warranty in clause 8.2 unless:

8.3.1 The Buyer has given the Seller specific written notice of any such alleged defect within seven (7) days of the date of delivery or (where the defect was not apparent on reasonable inspection) within fourteen (14) days of the date when the Buyer discovers or ought reasonably to have discovered the defect; and

8.3.2 The Seller has been afforded a reasonable opportunity of inspecting the Goods in question for the purpose of examining the nature and extent of the alleged defect.

8.4 The Seller's liability hereunder shall be limited exclusively to repair of or, at the Seller's option, replacement of the defective Goods which shall be sent carriage paid to the Seller's factory at Dukesway, Teesside Industrial Estate, Thornaby, and Cleveland or to such other place designated by the Seller on receipt of notice under clause 8.3.

8.5 Once in the Seller's hands the defective Goods may be modified at the Seller's option so as to ensure compliance with the warranty and, if replaced, the defective Goods shall become the property of the Seller. Replacement or repair of defective Goods shall not in any way extend the warranty period given under clause 8.2.

8.6 The Seller shall not be liable for any breach of the warranty in clause 8.2 where and to the extent that the defect arises from the Seller's conformance with the Buyer's specifications, or from the Buyer's negligence, wilful or accidental damage during or after delivery, fair wear and tear, bad handling, changes made to the Goods by the Buyer or third parties, undue strain placed on the Goods, unsuitable storage, lack of maintenance, improper installation, unusual environmental conditions, or other causes of a like nature.

8.7 If the Contract stipulates test or inspection of the Goods by or on behalf of the Buyer before delivery, such test and inspection shall be made at the Seller's place of manufacture and shall constitute the Buyer's final opportunity of ascertaining that the Goods are in conformity with the Contract. If upon reasonable notice the Buyer does not inspect or test the Goods or if having done so at the Seller's place of manufacture, the Buyer does not within 7 (seven) days thereafter notify the Seller in writing of any claim that the Goods are not in conformity with the Contract specifying the matters complained of then the Buyer shall be conclusively deemed as having accepted the Goods in accordance with the Contract and shall not thereafter be entitled to claim in any way in respect of the Goods.

8.8 Where Goods are already covered by an independently audited industry Quality Assurance Scheme under BSI/QAS 5020/304, the Seller reserves the right to charge for the cost and administration of additional in process inspections.

8.9 The Seller shall not be liable to the Buyer nor be deemed to be in breach of the Contract by reason of any delay in performing, or any failure to perform, any of the Seller's obligations in relation to the Goods, if the delay or failure was due to any cause beyond the Seller's reasonable control. Without prejudice to the generality of the foregoing, the following shall be regarded as causes beyond the Seller's reasonable control: strikes lock outs, breakdown of plant, fire, the elements, Act of God, and war.

8.10 Except in respect of death or personal injury caused by the Seller's negligence, the Seller shall not be liable to the Buyer for any indirect, special or consequential loss or damage (whether for loss of profit or otherwise), or other claims for compensation whatsoever (whether caused by the negligence of the Seller or otherwise) which arise out of or in connection with the supply of the Goods or their use or resale, and the entire liability of the Seller under or in connection with the Contract shall not exceed the price of the Goods, except as expressly provided in these Conditions.

9.1 Except as expressly provided for under clause 8 and in the absence of prior agreement between the Seller and the Buyer to the contrary, the Buyer shall not be entitled to return any Goods. Where non-defective Goods are returned by agreement between the Buyer and the Seller, a credit note will be issued by the Seller after the returned Goods have been received at the latter's works and have been checked. All transport costs to and from the Seller's works and other place of business including handling, packing and other like charges shall remain the sole responsibility of the Buyer and shall include the cost of reconditioning except where this is covered under the Seller's warranty contained in clause 8 hereof.

10.1 The Seller shall be entitled, without prejudice to any other right or remedy available to the Seller, either to terminate wholly or in part any or every Contract between itself and the Buyer or to suspend any further deliveries there under on the happening of any one of the following events:

10.1.1 If the Buyer has failed to take delivery of the goods from the Seller otherwise than in accordance with the Contract;

10.1.2 If the Buyer makes any voluntary arrangement with its creditors or (being an individual or a firm) becomes bankrupt or (being a company) becomes subject to an administration order or goes into liquidation (other than for the purposes of amalgamation or reconstruction), or if an encumbrancer takes possession, or a receiver is appointed, of any of the property or assets of the Buyer; or

10.1.3 the Buyer ceases, or threatens to cease, to carry on business; or

10.1.4 the Seller reasonably apprehends that any of the events mentioned in clause 10.1 is about to occur and notifies the Buyer accordingly.

11.1 The Buyer shall indemnify the Seller against all claims, demands, damages, penalties, cost, expenses for which the Seller may become liable by reason of the infringement or alleged infringement of third party intellectual property rights arising out of the Seller's performance of the Contract in accordance with the Buyer's specifications.

12.1 The Seller's rights shall not be prejudiced or restricted by any indulgence or forbearance extended to the Buyer and no waiver by the Seller in respect of any breach of the Contract by the Buyer shall operate as a waiver in respect of any subsequent breach of the same or any other provision.

12.2 This Contract shall be subject to and construed in accordance with the English Law.

Dimensional Key

Design Moments and Foundation Size.

The foundation data provided details concrete diameters and block sizes based upon the maximum capacities stated in the headload table. Please note however these headloads are showing the maximum achievable on the column to give an indication of the columns carrying capacity for additional equipment. If columns are being used for luminaires only the foundation sizes will reduce significantly. Please enquire to ascertain project specific foundation guidance based on intended designs.

Planted Root Columns: The data given in these tables in regards to minimum surrounding concrete diameters of foundations is based on upon the ground pressures given for the 3 soil types identified in Table 2 of PD6547:2004. The calculation method given in this standard has therefore been applied using the poorest soil conditions with a ground pressure of 230 kN/m² to give a figure for guidance only. More site specific calculations can be carried out at point of enquiry where site soil conditions are known.

Flange Plated Columns: The concrete foundation sizes given in the table above have been calculated using the Andree & Norsa method with a ground pressure of 20 N/cm² and has been given for guidance only. Site specific calculations should be carried out where the ground pressure in the vicinity of the lighting column is known.

Understanding The Tables.

Valmont Stainton produces a wide range of columns in many different shapes and sizes. The graphics below will help to define the dimensional abbreviations used throughout this brochure. Any dimensions or design aspects that are specific to a given model will be noted on the product page.

Dimensional Abbreviations.

| Height (m) | BD (mm) | TD (mm) | PD (mm) | DH x DW (mm) | Mass (kg) | OTM (kNm) | Shear (kN) | Min. Concrete Dia. (mm) |
|------------|---------|---------|---------|--------------|-----------|-----------|------------|-------------------------|
| 4 | 146 | 76 | 800 | 500 x 100 | 65 | 3,52 | 1,12 | 426 |
| 6 | 160 | 76 | 1000 | 500 x 100 | 65 | 6,10 | 1,38 | 372 |

* The 4m column is top Ø89mm with a Ø76mm spigot as standard.

Product Note. Applicable to specific products.

Traffic Structures.

BD = Base Diameter
 TD = Top Diameter
 PD = Plant Depth
 DH = Door Height
 DW = Door Width

SL = Side Length
 T = Thickness
 BC = Bolt Circle

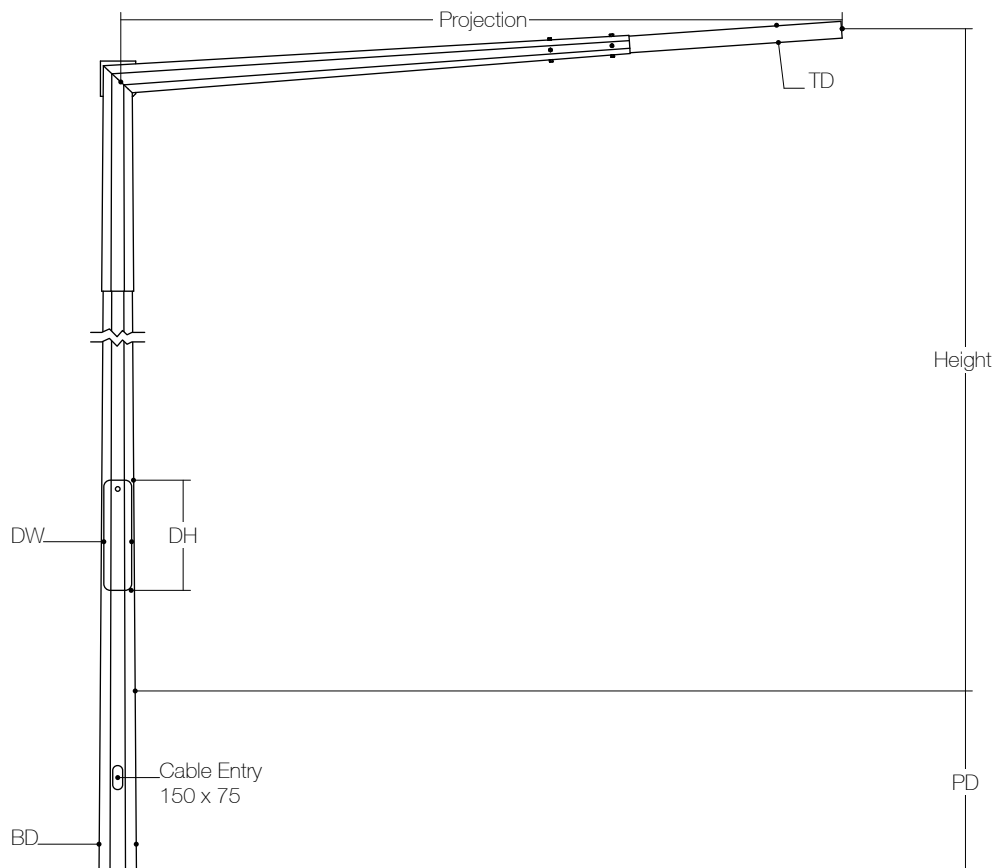
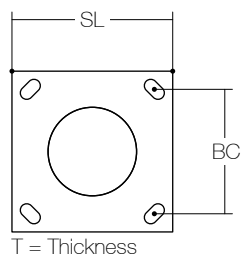

Tubular.

BD = Base Diameter
 SD = Shaft Diameter
 BH = Base Height
 SH = Shaft Height
 PD = Plant Depth
 DH = Door Height
 DW = Door Width

SL = Side Length
 T = Thickness
 BC = Bolt Circle

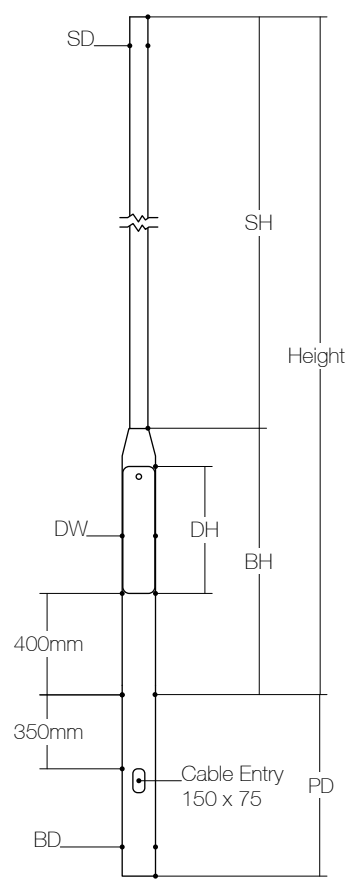
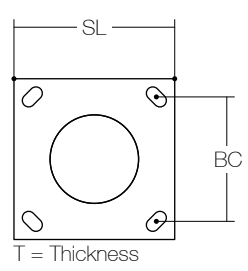

Parallel. Octagonal. Conical.

BD = Base Diameter
 TD = Top Diameter
 PD = Plant Depth
 DH = Door Height
 DW = Door Width

SL = Side Length
 T = Thickness
 BC = Bolt Circle

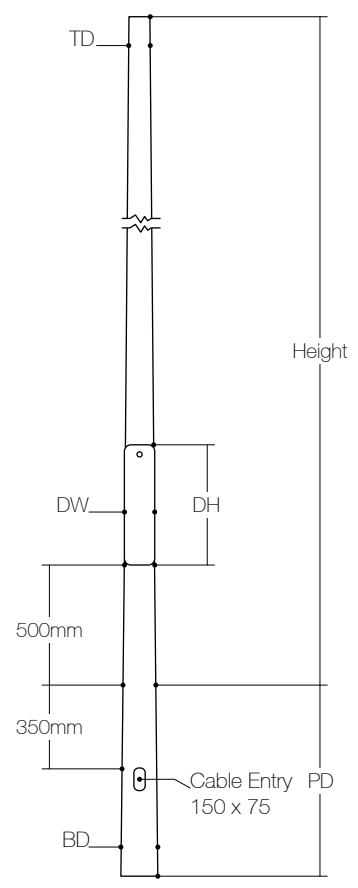
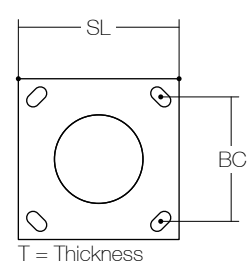

Hinged.

BD = Base Diameter
 SK D = Skirt Diameter
 SD = Shaft Diameter
 TD = Top Diameter
 BH = Base Height
 SH = Shaft Height
 PD = Plant Depth
 DH = Door Height
 DW = Door Width

SL = Side Length
 T = Thickness
 BC = Bolt Circle

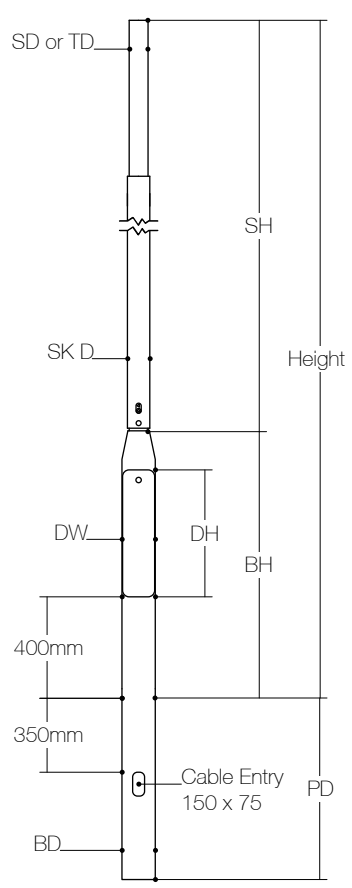
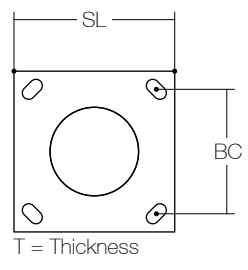

Wooden.

BD = Base Diameter
 BH = Base Height
 TD = Top Diameter
 WH = Wood Height
 PD = Plant Depth
 DH = Door Height
 DW = Door Width

SL = Side Length
 T = Thickness
 BC = Bolt Circle

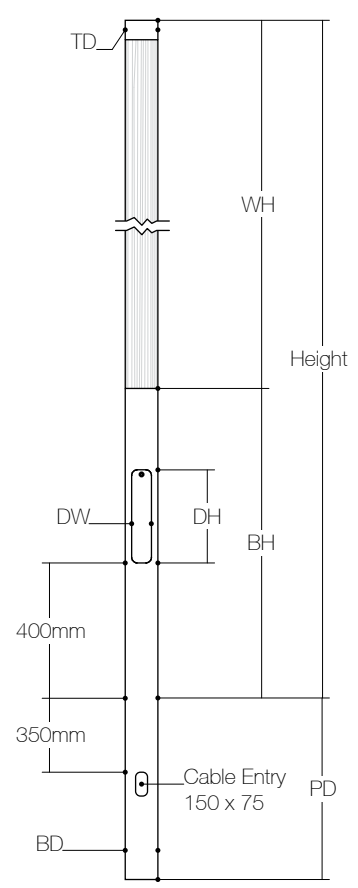
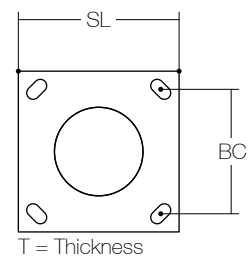

General Recommendations

Recommendations.

Adding anything not specified in the original order may alter the lighting column's resistance. Specify when ordering if the installation site is likely to be subject to vibratory phenomena (bridges, paving, etc.). If known, specify when ordering the type of load and the place of installation of the lighting columns.

Make sure that your load (lights, signs, banners, etc.) can be borne using catalogue information or sales literature. Conventional reported values must on no account be used to define the choice of a mast in respect of its location. Wind resistance charts, according to areas and categories of terrain, should be used to define and validate the choice of a product. Any mechanical tests in situ must give rise to a written request to Valmont so that we can communicate the elements necessary for conducting these tests. Without such a request, the manufacturer's guarantee will not apply.

Storage & Handling.

We recommend you do not store lamp posts directly on the ground or nearby areas where pulverulent materials are stored.

Painted products should not be stored on the floor or near areas of excessive acidic or alkaline products; such as rock salt

We advise you not to stock painted products for long periods of time without adequate ventilation. In the case of prolonged storage (> 3 weeks), remove all steel straps & packaging.

Products should be handled with the help of nonmetallic slings, or a trolley with protected forks, in order to avoid scratching. The lamp posts must only be raised by the pole.

Cleaning.

Regularly clean the surfaces of masts in galvanised steel and in aluminium alloy, using soapy water for untreated masts and polish for painted masts.

Make sure the products used are nonabrasive. Under no circumstances should corrosive products or scouring pads be used to clean Valmont columns.

Checks & Maintenance.

Each time the lamps are serviced, check that all accessories and brackets are properly fastened (check that all screws and bolts are installed and fastened tightly, check the lantern is fixed securely to the mast arm).

Make yearly checks on:

Inspection Doors:

Presence and correct fit of the door. Inspect the state of the mobile bolt screws, including oiling. Evacuate standing water. Clean the bottom of the mast.

The Foundation:

Visually check the foundation. Whether it is perpendicular in relation to the ground. Ground compacting around the foundation. Cracking.

Embedding Rods.

Oil the threads. Check tightness. Unblock discharge hole. Check rod/base plate insulation present.

Wooden Column Maintenance.

For detailed information regarding the recommended maintenance schedule for Valmont wooden columns please contact your local representative or visit the following web page: <http://www.woodenpoles.com/downloads>

Thanks.

We thank those who have taken part in the design, development and manufacture of the products seen in this catalogue. We would also like to thank those who have actively worked to create, compose and develop this catalogue. Thank you very much for all your help!

Photo & Lantern Credits.

Anish Samani, Ilpo Alto, John Boddy, Valmont, DW Windsor, Holophane, iGuzzini, Inolumis, Martin, Meyer Lighting, Musco, Philips, Ragni, ROHL, Schröder, Siteco, and Thorn.

This document is the intellectual property of Valmont Stainton. It may not be reproduced, even partially, nor even passed on without authorisation. Valmont Stainton reserves the right to make any modifications as may be necessary for the technical or aesthetic improvement of its products without notice.

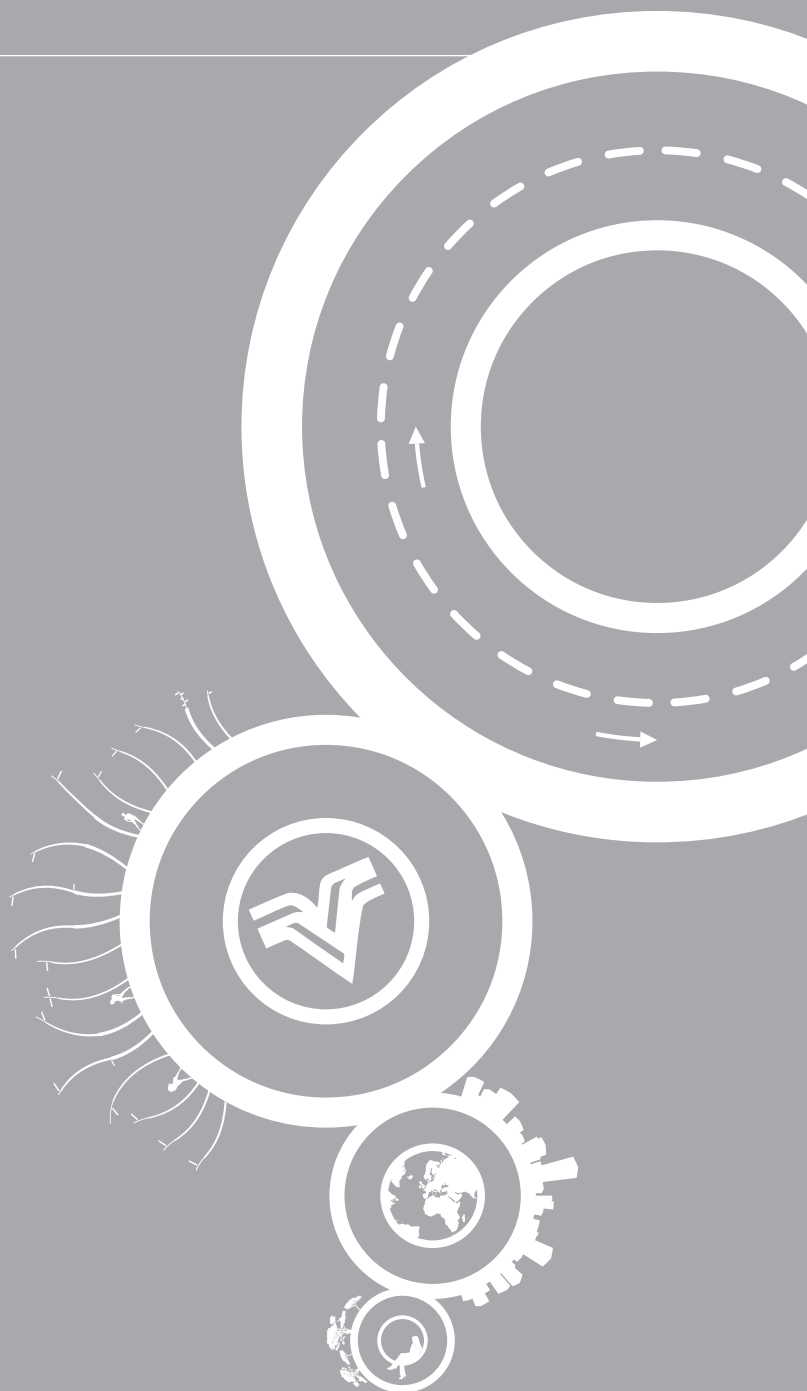

Valmont Stainton Ltd
Dukesway Teesside Industrial Estate
Thornaby, Stockton-on-Tees TS17 9LT
T: (+44) 01642 766242
Email: stainton@valmont.com
Web: www.valmont-stainton.com
Web: www.deco.valmont-stainton.com

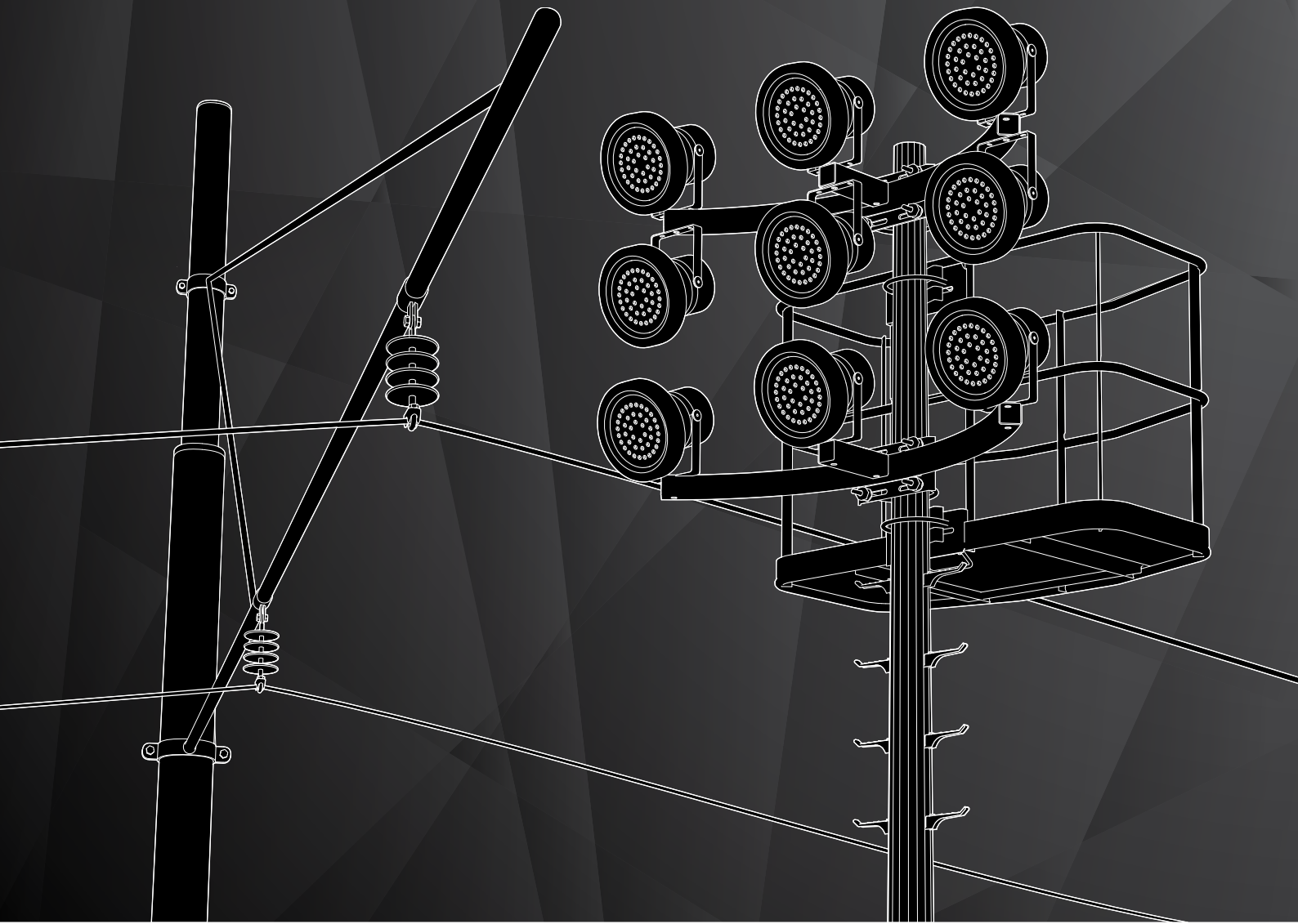

valmont 
STANTON



Valmont Stainton Ltd
Dukesway Teesside Industrial Estate
Thornaby, Stockton-on-Tees TS17 9LT
T: (+44) 01642 766242
E: stainton@valmont.com
www.deco.valmont-stainton.com